



(43) International Publication Date
10 September 2020 (10.09.2020)

(51) International Patent Classification:

G01N 15/06 (2006.01)	G01N 21/17 (2006.01)
A24F 40/40 (2020.01)	G01N 21/51 (2006.01)
G01F 1/86 (2006.01)	G01N 21/59 (2006.01)
G01F 1/88 (2006.01)	G01N 25/08 (2006.01)
G01G 17/04 (2006.01)	G06M 11/00 (2006.01)
G01N 15/02 (2006.01)	G01F 1/36 (2006.01)
G01N 15/10 (2006.01)	

(21) International Application Number:

PCT/CA2020/050292

(22) International Filing Date:

05 March 2020 (05.03.2020)

(25) Filing Language:

English

(26) Publication Language:

English

(30) Priority Data:

62/813,845	05 March 2019 (05.03.2019)	US
62/899,828	13 September 2019 (13.09.2019)	US

(71) Applicant: CANOPY GROWTH CORPORATION

[CA/CA]; 1 Hershey Drive, Smiths Falls, Ontario K7A 0A8 (CA).

(72) Inventors: DAVIS, Stephen; 513 Westminster Avenue,

Ottawa, Ontario K2J 1G8 (CA). EVANS, Philip; 1 Hershey Drive, Smiths Falls, Ontario K7A 0A8 (CA). KRAW-CZYK, Steve; 2130 Barbara Drive, Palo Alto, California 94303 (US). PENNEY, Steven; 18 Springwater Drive, Ottawa, Ontario K2M 2J7 (CA). PICCOLI, John; 1 Hershey Drive, Smiths Falls, Ontario K7A 0A8 (CA). ROSS, Alexander; 1149 Clyde Avenue, Ottawa, Ontario K2C 4B2 (CA). STEWART, Andrew; 21 Andrea Crescent, Ottawa, Ontario K2J 1G8 (CA).

(74) Agent: AIRD & MCBURNEY LP; Brookfield Place, 181

Bay Street, Suite 1800, Toronto, Ontario M5J 2T9 (CA).

(81) Designated States (unless otherwise indicated, for every

kind of national protection available): AE, AG, AL, AM, AO, AT, AU, AZ, BA, BB, BG, BH, BN, BR, BW, BY, BZ, CA, CH, CL, CN, CO, CR, CU, CZ, DE, DJ, DK, DM, DO, DZ, EC, EE, EG, ES, FI, GB, GD, GE, GH, GM, GT, HN,

(54) Title: SYSTEM AND METHOD FOR MEASURING PAYLOAD DOSAGE IN A VAPORIZATION DEVICE

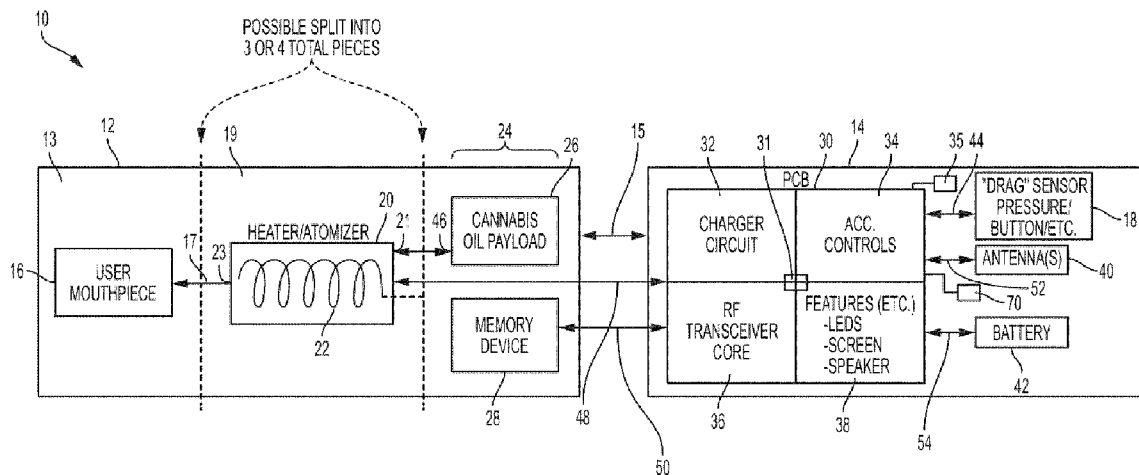

FIG. 1

(57) Abstract: Vape devices and methods configured to determine the dose of a payload delivered to a user during user inhalations are described. In some aspects the vape device: tracks the energy used to vaporize a portion of the payload during user inhalation to determine the dose; measures the temperature at multiple locations within the air flow chamber during user inhalation to determine the dose; measures the intensity of light that is transmitted through the vaporized payload, reflected off the vaporized payload, or transmitted through a light transmitting medium positioned within the vaporized payload, during user inhalation to determine the dose; and, utilizes hot wire anemometers to determine the mass of the vaporized payload delivered to the user during inhalation and/or to determine the size and density distribution of the droplets in the vaporized payload for calculating the total mass of the vaporized payload delivered to the user during each inhalation.



HR, HU, ID, IL, IN, IR, IS, JO, JP, KE, KG, KH, KN, KP, KR, KW, KZ, LA, LC, LK, LR, LS, LU, LY, MA, MD, ME, MG, MK, MN, MW, MX, MY, MZ, NA, NG, NI, NO, NZ, OM, PA, PE, PG, PH, PL, PT, QA, RO, RS, RU, RW, SA, SC, SD, SE, SG, SK, SL, ST, SV, SY, TH, TJ, TM, TN, TR, TT, TZ, UA, UG, US, UZ, VC, VN, WS, ZA, ZM, ZW.

(84) Designated States (*unless otherwise indicated, for every kind of regional protection available*): ARIPO (BW, GH, GM, KE, LR, LS, MW, MZ, NA, RW, SD, SL, ST, SZ, TZ, UG, ZM, ZW), Eurasian (AM, AZ, BY, KG, KZ, RU, TJ, TM), European (AL, AT, BE, BG, CH, CY, CZ, DE, DK, EE, ES, FI, FR, GB, GR, HR, HU, IE, IS, IT, LT, LU, LV, MC, MK, MT, NL, NO, PL, PT, RO, RS, SE, SI, SK, SM, TR), OAPI (BF, BJ, CF, CG, CI, CM, GA, GN, GQ, GW, KM, ML, MR, NE, SN, TD, TG).

Declarations under Rule 4.17:

— *as to applicant's entitlement to apply for and be granted a patent (Rule 4.17(ii))*

Published:

— *with international search report (Art. 21(3))*
— *in black and white; the international application as filed contained color or greyscale and is available for download from PATENTSCOPE*

SYSTEM AND METHOD FOR MEASURING PAYLOAD DOSAGE IN A VAPORIZATION DEVICE

Cross-Reference to Related Applications

This application is based on and claims priority to U.S. Provisional Application
5 Serial No. 62/813,845, filed on March 5, 2019, and U.S. Provisional Application Serial No.
62/899,828, filed on September 13, 2009, each of which is incorporated herein by reference in
its entirety.

Background of the Invention

1. Field of the Invention

10 The present disclosure is generally related to the field of personal vaporizer
devices and, in particular, to systems and methods for measuring the dosage of a vaporized
payload that is delivered to the user of a personal vaporizer device.

2. Description of Related Art

15 The use of personal vaporizer devices or "vape devices" for consuming
cannabis, tobacco products, and other substances has grown significantly. In a basic form, a
vape device consists of an atomizer, a battery, a switch for connecting the battery to the
atomizer, and a reservoir that contains an amount of payload (e.g., cannabis oil) to be vaporized
by the atomizer. Controlling the vape device merely entails closing the switch so that current
20 passes from the battery through a coil of the atomizer whereby the atomizer heats up and begins
to vaporize a portion of the payload. The vapor—i.e., the cloud-like emission from a vape
device that may be some combination of actual gas phase vapor and aerosol—is then inhaled
by the user so that the desired components (e.g., THC, CBD, etc.) are delivered for medical or
recreational purposes.

25 While there are a few conventional vape devices that attempt to determine the
dosage of a vaporized payload delivered to a user, they use inaccurate methods that offer poor
dose metering performance. It is technically difficult to accurately measure the dose
administered by a vape device because, for example, vapor density can be inconsistent and
operating conditions will vary. As such, medicinal patients are unsure of the dosage that they
30 have consumed at any given time, which limits the repeatability and efficacy of the drug's
effects. Also, recreational users may experience different effects (desirable and undesirable)
depending on dosage. Thus, there remains a need in the art for a vape device that accurately
measures the dose of a payload delivered to a user and/or that offers other advantages compared
to conventional vape devices.

Brief Summary of the Invention

The present invention is directed to a vape device for determining the dose of a payload delivered to a user during each of a plurality of user inhalations (commonly referred to as a "draw" or "drag" or "puff"). The vape device may use four different methods, independently or in any combination, to measure the portion of the payload that is vaporized during each user inhalation. The first method tracks the energy used to vaporize the payload portion during user inhalation in order to determine the mass of the vaporized payload; the second method measures the temperature at multiple locations within the air flow chamber during the user inhalation (and optionally before and after the user inhalation) to determine the vapor density and by extension the mass of the vaporized payload; the third method measures the intensity of light that is transmitted through the vaporized payload, reflected off the vaporized payload, or transmitted through a light transmitting medium positioned within the vaporized payload, before, during, and after user inhalation to determine the vapor density and by extension the mass of the vaporized payload; and the fourth method utilizes hot wire anemometers to determine the mass of the vaporized payload that was delivered to the user during each user inhalation and/or to determine the size and density distribution of the droplets in the vaporized payload and use such distribution to calculate the total mass of the vaporized payload that was delivered to the user during each user inhalation. More accurate dose metering is beneficial to both medicinal and recreational users insofar as they will be able to accurately measure their dosage to obtain the desired effects in a repeatable fashion.

A vape device for determining a dose of a payload delivered to a user during each of a plurality of user inhalations in accordance with one exemplary embodiment of the invention described herein comprises: a payload reservoir configured to contain a payload to be vaporized; a power source configured to generate a power signal during each respective user inhalation; an atomizer configured to receive the power signal and vaporize a portion of the payload to thereby generate a vaporized payload during each respective user inhalation; and a microcontroller programmed to determine a dose of the vaporized payload for each respective user inhalation based on: (a) determining an amount of energy used to vaporize the portion of the payload during the user inhalation; and (b) determining a partial mass of the payload that is vaporized during the user inhalation based on the amount of energy used to vaporize the portion of the payload during the user inhalation.

A method for determining a dose of a payload delivered to a user of a vape device during each of a plurality of user inhalations in accordance with another exemplary

- 3 -

embodiment of the invention described herein comprises: holding a payload to be vaporized; vaporizing a portion of the payload by transmitting a power signal from a power source to an atomizer to thereby generate a vaporized payload during each respective user inhalation; and determining a dose of the vaporized payload for each respective user inhalation based on:

5 (a) determining an amount of energy used to vaporize the portion of the payload during the user inhalation; and (b) determining a partial mass of the payload that is vaporized during the user inhalation based on the amount of energy used to vaporize the portion of the payload during the user inhalation.

A vape device for determining a dose of a payload delivered to a user during

10 each of a plurality of user inhalations in accordance with another exemplary embodiment of the invention described herein comprises: a payload reservoir configured to contain a payload to be vaporized; an air flow chamber that extends between an inlet and an outlet; an atomizer positioned between the inlet and the outlet of the air flow chamber, wherein the atomizer is configured to vaporize a portion of the payload to thereby generate a vaporized payload during

15 each respective user inhalation; and a microcontroller programmed to determine a dose of the vaporized payload for each respective user inhalation based on: (a) a plurality of temperature measurements obtained within the air flow chamber during the user inhalation; and (b) an air flow rate within the air flow chamber during the user inhalation.

A method for determining a dose of a payload delivered to a user of a vape

20 device during each of a plurality of user inhalations in accordance with another exemplary embodiment of the invention described herein comprises: holding a payload to be vaporized; vaporizing a portion of the payload with an atomizer positioned between an inlet and an outlet of an air flow chamber to thereby generate a vaporized payload during each respective user inhalation; and determining a dose of the vaporized payload for each respective user inhalation

25 based on: (a) a plurality of temperature measurements obtained within the air flow chamber during the user inhalation; and (b) an air flow rate within the air flow chamber during the user inhalation.

A vape device for determining a dose of a payload delivered to a user during

each of a plurality of user inhalations in accordance with another exemplary embodiment of

30 the invention described herein comprises: a payload reservoir configured to contain a payload to be vaporized; an air flow chamber that extends between an inlet and an outlet; an atomizer positioned between the inlet and the outlet of the air flow chamber, wherein the atomizer is configured to vaporize a portion of the payload to thereby generate a vaporized payload during

- 4 -

each respective user inhalation; and a microcontroller programmed to determine a dose of the vaporized payload for each respective user inhalation based on a plurality of light intensity measurements obtained during the user inhalation, wherein the light intensity measurements are associated with light that is transmitted through the vaporized payload, reflected off the vaporized payload, or transmitted through a light transmitting medium positioned within the vaporized payload, when the vaporized payload passes through the air flow chamber.

A method for determining a dose of a payload delivered to a user of a vape device during each of a plurality of user inhalations in accordance with another exemplary embodiment of the invention described herein comprises: holding a payload to be vaporized; vaporizing a portion of the payload with an atomizer positioned between an inlet and an outlet of an air flow chamber to thereby generate a vaporized payload during each respective user inhalation; and determining a dose of the vaporized payload for each respective user inhalation based on a plurality of light intensity measurements obtained during the user inhalation, wherein the light intensity measurements are associated with light that is transmitted through the vaporized payload, reflected off the vaporized payload, or transmitted through a light transmitting medium positioned within the vaporized payload, when the vaporized payload passes through the air flow chamber.

A vape device for determining a dose of a payload delivered to a user during each of a plurality of user inhalations in accordance with another exemplary embodiment of the invention described herein comprises: a payload reservoir configured to contain a payload to be vaporized; an air flow chamber that extends between an inlet and an outlet; an atomizer located between the inlet and the outlet of the air flow chamber, wherein the atomizer is configured to vaporize a portion of the payload to thereby generate a vaporized payload during each respective user inhalation; at least one sampling hot wire anemometer located within the air flow chamber between the atomizer and the outlet, wherein the sampling hot wire anemometer is incorporated into a circuit configured to determine a number of droplets of the vaporized payload passing by the sampling hot wire anemometer during each respective user inhalation; and a microcontroller programmed to determine a dose of the vaporized payload for each respective user inhalation based on the number of droplets of the vaporized payload.

A method for determining a dose of a payload delivered to a user of a vape device during each of a plurality of user inhalations in accordance with another exemplary embodiment of the invention described herein comprises: holding a payload to be vaporized; vaporizing a portion of the payload with an atomizer positioned between an inlet and an outlet

- 5 -

of an air flow chamber to thereby generate a vaporized payload during each respective user inhalation; determining a number of droplets of the vaporized payload passing by at least one sampling hot wire anemometer located within the air flow chamber between the atomizer and the outlet during each respective user inhalation; and determining a dose of the vaporized payload for each respective user inhalation based on the number of droplets of the vaporized payload.

Various other embodiments and features of the present invention are described in detail below with reference to the attached drawing figures, or will be apparent to those skilled in the art based on the disclosure provided herein, or may be learned from the practice of the invention.

Brief Description of the Drawings

FIG. 1 is a schematic diagram of a first embodiment of a vape device in accordance with the invention described herein.

FIG. 2 is a schematic diagram of a second embodiment of a vape device in accordance with the invention described herein.

FIG. 3 is a schematic diagram of an embodiment of a vape device system that includes the vape device of FIG. 1 in wireless communication with a personal computing device.

FIG. 4 is a schematic diagram of an exemplary vape device that utilizes an energy usage method to determine the dose of vaporized payload delivered to a user.

FIG. 5 is a schematic diagram of an exemplary vape device that utilizes a temperature measurement method to determine the dose of vaporized payload delivered to a user.

FIGS. 6-13 are schematic diagrams of exemplary vape devices that utilize various light intensity measurement methods to determine the dose of vaporized payload delivered to a user.

FIG. 14 is a schematic diagram of an exemplary vape device that utilizes hot wire anemometers to determine the dose of vaporized payload delivered to a user.

FIG. 15 is a block diagram of exemplary components that may be incorporated into a vape device to determine the dose of vaporized payload delivered to a user and to determine the size and density distribution of the droplets in the vaporized payload.

Detailed Description of Preferred Embodiment

The present invention is directed to a vape device for determining the dose of a payload delivered to a user during each of a plurality of user inhalations. While the invention will be described in detail below with reference to various exemplary embodiments, it should be understood that the invention is not limited to the specific configuration or methodologies of any of these embodiments. In addition, although the exemplary embodiments are described as embodying several different inventive features, those skilled in the art will appreciate that any one of these features could be implemented without the others in accordance with the invention.

In this description, references to "one embodiment," "an embodiment," "an exemplary embodiment," or "embodiments" mean that the feature or features being described are included in at least one embodiment of the invention. Separate references to "one embodiment," "an embodiment," "an exemplary embodiment," or "embodiments" in this description do not necessarily refer to the same embodiment and are also not mutually exclusive unless so stated and/or except as will be readily apparent to those skilled in the art from the description. For example, a feature, structure, function, etc. described in one embodiment may also be included in other embodiments, but is not necessarily included. Thus, the present invention can include a variety of combinations and/or integrations of the embodiments described herein.

In this disclosure, the term "payload" refers to any payload suitable for a vape device. Non-limiting examples include a payload comprising nicotine, cannabis, a cannabinoid or a cannabis concentrate as an ingredient. The payload may include other components such as, without limitation, a viscosity modifying agent, a stabilizer, and a flavorant.

As used herein, the term "nicotine" can be of plant origin or of synthetic or semi-synthetic origin. For example, it can be extracted from tobacco leaves or obtained by chemical synthesis. Nicotine may also refer to a nicotine substitute, which is typically a molecule that is not addictive but has a sensory effect similar to that of nicotine.

As used herein, the term "cannabis" refers to a genus of flowering plant in the family Cannabaceae. The number of species within the genus is disputed. Three species may be recognized, *Cannabis sativa*, *Cannabis indica* and *Cannabis ruderalis*. *C. ruderalis* may be included within *C. sativa*; or all three may be treated as subspecies of a single species, *C. sativa*. The genus is indigenous to central Asia and the Indian subcontinent.

- 7 -

Cannabis has long been used for hemp fiber, hemp oils, medicinal purposes, and as a recreational drug. Industrial hemp products are made from cannabis plants selected to produce an abundance of fiber. To satisfy the UN Narcotics Convention, some cannabis strains have been bred to produce minimal levels of tetrahydrocannabinol (THC), the principal psychoactive constituent. Many additional plants have been selectively bred to produce a maximum level of THC. Various compounds, including hashish and hash oil, may be extracted from the plant.

Within naturally occurring and manmade hybrids, cannabis contains a vast array of compounds. Three compound classes are of interest within the context of the present disclosure, although other compounds can be present or added to the compositions to optimize the experience of a given recreational consumer and medical or medicinal patient or patient population. Those classes include cannabinoids, terpenes and flavonoids.

There are many ways of growing cannabis, some of which are natural, and some are carefully designed by humans, and they will not be recited here. However, one of ordinary skill in the art of cannabis production will typically place a cannabis seed or cutting into a growth media such as soil, manufactured soil designed for cannabis growth or one of many hydroponic growth media. The cannabis seed or cutting is then provided with water, light and, optionally, a nutrient supplement. At times, the atmosphere and temperature are manipulated to aid in the growth process. Typically, the humidity, air to carbon dioxide gas ratio and elevated temperature, either by use of a heat source or waste heat produced by artificial light, are used. On many occasions ventilation is carefully controlled to maintain the conditions described above within an optimal range to both increase the rate of growth and, optionally, maximize the plant's production of the compounds, which comprise the compositions of the disclosure. It is possible to control lighting cycles to optimize various growth parameters of the plant.

Given the number of variables and the complex interaction of the variables, it is possible to develop highly specific formulas for production of cannabis which lead to a variety of desired plant characteristics. The present disclosure is applicable to use with such inventive means for growing cannabis as well as any of the variety of conventional methods.

Cannabis sativa is an annual herbaceous plant in the Cannabis genus. It is a member of a small, but diverse family of flowering plants of the Cannabaceae family. It has been cultivated throughout recorded history, used as a source of industrial fiber, seed oil, food, recreation, religious and spiritual moods and medicine. Each part of the plant is harvested

- 8 -

differently, depending on the purpose of its use. The species was first classified by Carl Linnaeus in 1753.

Cannabis indica, formally known as *Cannabis sativa* forma *indica*, is an annual plant in the Cannabaceae family. A putative species of the genus *Cannabis*.

5 *Cannabis ruderalis* is a low-THC species of *Cannabis*, which is native to Central and Eastern Europe and Russia. It is widely debated as to whether *C. ruderalis* is a sub-species of *Cannabis sativa*. Many scholars accept *Cannabis ruderalis* as its own species due to its unique traits and phenotypes that distinguish it from *Cannabis indica* and *Cannabis sativa*.

10 As used herein, the term "cannabinoid" refers to a chemical compound belonging to a class of secondary compounds commonly found in plants of genus *cannabis*, but also encompasses synthetic and semi-synthetic cannabinoids.

The most notable cannabinoid is tetrahydrocannabinol (THC), the primary psychoactive compound in *cannabis*. Cannabidiol (CBD) is another cannabinoid that is a major constituent of the phytocannabinoids. There are at least 113 different cannabinoids isolated
15 from *cannabis*, exhibiting varied effects.

Synthetic cannabinoids and semi-synthetic cannabinoids encompass a variety of distinct chemical classes, for example and without limitation: the classical cannabinoids structurally related to THC, the non-classical cannabinoids (cannabimimetics) including the aminoalkylindoles, 1,5 diarylpyrazoles, quinolines, and arylsulfonamides as well as
20 eicosanoids related to endocannabinoids.

In many cases, a cannabinoid can be identified because its chemical name will include the text string "*cannabi*". However, there are a number of cannabinoids that do not use this nomenclature.

25 Within the context of this disclosure, where reference is made to a particular cannabinoid, each of the acid and/or decarboxylated forms are contemplated as both single molecules and mixtures. In addition, salts of cannabinoids are also encompassed, such as salts of cannabinoid carboxylic acids.

As well, any and all isomeric, enantiomeric, or optically active derivatives are also encompassed. In particular, where appropriate, reference to a particular cannabinoid
30 includes both the "A Form" and the "B Form". For example, it is known that THCA has two isomers, THCA-A in which the carboxylic acid group is in the 1 position between the hydroxyl group and the carbon chain (A Form) and THCA-B in which the carboxylic acid group is in the 3 position following the carbon chain (B Form).

- 9 -

Examples of cannabinoids include, but are not limited to: cannabigerolic acid (CBGA), cannabigerolic acid monomethylether (CBGAM), cannabigerol (CBG), cannabigerol monomethylether (CBGM), cannabigerovarinic acid (CBGVA), cannabigerovarin (CBGV), cannabichromenic Acid (CBCA), cannabichromene (CBC), cannabichromevarinic Acid (CBCVA), cannabichromevarin (CBCV), cannabidiolic acid (CBDA), cannabidiol (CBD), Δ 6-cannabidiol (Δ 6 CBD), cannabidiol monomethylether (CBDM), cannabidiol-C4 (CBD-C4), cannabidivarinic Acid (CBDVA), cannabidivarin (CBDV), cannabidiorcol (CBD-C1), tetrahydrocannabinolic acid A (THCA-A), tetrahydrocannabinolic acid B (THCA-B), tetrahydrocannabinol (THC or Δ 9-THC), Δ 8 tetrahydrocannabinol (Δ 8-THC), trans- Δ 10-tetrahydrocannabinol (trans- Δ 10-THC), cis Δ 10-tetrahydrocannabinol (cis- Δ 10-THC), tetrahydrocannabinolic acid C4 (THCA-C4), tetrahydrocannabinol C4 (THC C4), tetrahydrocannabivarinic acid (THCVA), tetrahydrocannabivarin (THCV), Δ 8-tetrahydrocannabivarin (Δ 8-THCV), Δ 9 tetrahydrocannabivarin (Δ 9-THCV), tetrahydrocannabiorcolic acid (THCA-C1), tetrahydrocannabiorcol (THC-C1), Δ 7-cis-iso-tetrahydrocannabivarin, Δ 8 tetrahydrocannabinolic acid (Δ 8-THCA), Δ 9-tetrahydrocannabinolic acid (Δ 9-THCA), cannabicyclic acid (CBLA), cannabicyclol (CBL), cannabicyclovarin (CBLV), cannabielsoic acid A (CBEA-A), cannabielsoic acid B (CBEA-B), cannabielsoin (CBE), cannabinolic acid (CBNA), cannabinol (CBN), cannabinol methylether (CBNM), cannabinol-C4 (CBN-C4), cannabivarin (CBV), cannabino-C2 (CBN-C2), cannabiorcol (CBN-C1), cannabinodiol (CBND), cannabinodivarin (CBDV), cannabitriol (CBT), 11 hydroxy- Δ 9-tetrahydrocannabinol (11-OH-THC), 11 nor 9-carboxy- δ 9-tetrahydrocannabinol, ethoxy-cannabitriolvarin (CBTVE), 10 ethoxy-9-hydroxy- δ 6a-tetrahydrocannabinol, cannabitriolvarin (CBTV), 8,9 dihydroxy- Δ 6a(10a)-tetrahydrocannabinol (8,9-Di-OH-CBT-C5), dehydrocannabifuran (DCBF), cannabifuran (CBF), cannabichromanon (CBCN), cannabicitran (CBT), 10 oxo- Δ 6a(10a)-tetrahydrocannabinol (OTHC), Δ 9 cis tetrahydrocannabinol (cis THC), cannabiripsol (cbr), 3,4,5,6-tetrahydro-7-hydroxy-alpha-alpha-2-trimethyl-9-n-propyl-2,6-methano-2h-1-benzoxocin-5-methanol (OH-iso-HHCV), trihydroxy-delta-9-tetrahydrocannabinol (triOH-THC), yangonin, epigallocatechin gallate, dodeca-2e, 4e, 8z, 10z-tetraenoic acid isobutylamide, hexahydrocannibinol, and dodeca-2e,4e-dienoic acid isobutylamide.

In some embodiments of the present disclosure, the cannabinoid is a cannabinoid dimer. The cannabinoid may be a dimer of the same cannabinoid (e.g.,

- 10 -

THC—THC) or different cannabinoids. In an embodiment of the present disclosure, the cannabinoid may be a dimer of THC, including for example cannabisol.

As used herein, the term "cannabis concentrate" refers to a mixture of compounds that is obtained from a cannabis plant, such as for example a mixture of compounds or compositions that have been extracted from cannabis. The cannabis concentrate may be a concentrated composition of cannabis-derived cannabinoids, terpenes, terpenoids, and other naturally occurring compounds found in the cannabis plant. Non-limiting embodiments of a cannabis concentrate include a cannabis distillate, a cannabis isolate, a cannabis resin, a cannabis derived cannabinoid, or any other type of extract containing one or more cannabinoids or terpenes, terpenoids, and other naturally occurring compounds found in the cannabis plant.

As used herein, the term "viscosity control agent" describes a substance for controlling and maintaining the viscosity of the payload. Non-limiting embodiments of a viscosity control agent include propylene glycol (1,2-propanediol), 1,3-propanediol, polyethylene glycol, vegetable glycerin, a terpene, triacetin, diacetin and triethyl citrate.

As used herein, the term "stabilizer" is any substance used to prevent an unwanted change in state. The stabilizer may be used to improve or maintain the stability of the payload. For example, without a stabilizer, cannabinoids or cannabis concentrates may be susceptible to degradation, such as oxidative degradation, cannabinoids may crystallize out of the payload, and/or the payload may undergo color change.

As used herein, the term "flavorant" is used to describe a compound or combination of compounds that may provide flavor and/or aroma to the payload. The flavorant may include at least one of a natural flavorant or an artificial flavorant. Non-limiting embodiments of a flavorant may be a tobacco flavor, menthol, wintergreen, peppermint, herb flavors, fruit flavors, nut flavors, liquor flavors and terpene flavors.

I. Vape Device

The present invention is directed to a vape device that measures and preferably controls or meters the dose of vaporized payload inhaled by the user. The dose metering technology may be incorporated into a variety of different types of vape devices available in various sizes in terms of the amount of payload they can contain. In one embodiment, the vape device comprises a self-contained vape device, e.g., a one piece disposable vape device in which all of the components are contained within a single housing. In another embodiment, the vape device comprises a control assembly and cartridge that are formed in separate housings and releasably connected to each other via an electromechanical connection. In this

- 11 -

embodiment, the control assembly is provided as a re-useable component that can be used with multiple disposable cartridges. In yet another embodiment, the vape device comprises a tabletop or desktop vaporizer.

5 Various embodiments of vape devices that may incorporate the dose metering technology of the present invention are described below in connection with FIGS. 1-3. In some embodiments, the vape devices can communicate with a personal computing device and work interactively with an application or "app" operating on the personal computing device to provide additional functions and features that enable implementation of certain aspects of the invention. Of course, it should be understood that the present invention is not limited to these
10 embodiments and that other types of vape devices may also be used within the scope of the invention.

For the sake of simplicity, the vape devices described in connection with FIGS. 1-3 are provided to describe the general structural configuration of the vape devices and do not include all of the various components and circuits required to provide the dose metering
15 technology of the present invention; rather, these components and circuits are described below in connection with the vape devices shown in FIGS. 4-10.

First Embodiment of Vape Device

Referring to FIG. 1, a first embodiment of a vape device is shown generally as reference numeral 10. Vape device 10 includes a mouthpiece assembly 12, an atomizer
20 assembly 19, a payload assembly 24, and a control assembly 14. Any of mouthpiece assembly 12, atomizer assembly 19, payload assembly 24, and control assembly 14 may be formed integrally together and included within a common housing suitable for grasping by a user. Further, any of mouthpiece assembly 12, atomizer assembly 19, payload assembly 24, and control assembly 14 may be formed in separate housings that are releasably connected to each
25 other via connecting means 15, which can comprise, for example, one or more of pressure or friction fit connection means, twist mechanical lock means, magnetic connection means and any other connecting means as well known to those skilled in the art. The connecting means 15 may include a female 510 threaded connector on the control assembly 14 that releasably engages a male 510 threaded connector on the atomizer assembly 19 or payload assembly 24.
30 A 510 threaded connector, as is known in the art, is a M7-0.5x5 threaded connector, i.e., a threaded connector with a nominal diameter of 7 mm, a pitch of 0.5 mm, and a length of 5 mm. Connecting means 15 may include threaded connectors of other sizes. By way of example, mouthpiece assembly 12 may be releasably connected to atomizer assembly 19, payload

- 12 -

assembly 24 and control assembly 14, which are either formed integrally together or in separate housings that are releasably connected to each other. Mouthpiece assembly 12 and atomizer assembly 19 may be formed integrally together and releasably connected to payload assembly 24 and control assembly 14, which are either formed integrally together or in separate housings that are releasably connected to each other. Further, mouthpiece assembly 12, atomizer assembly 19, and payload assembly 24 may be formed integrally together and releasably connected to control assembly 14. The combination of the mouthpiece assembly 12, atomizer assembly 19, and payload assembly 24 may be referred to as a cartridge herein. It is also within the scope of the invention for the mouthpiece assembly 12 to be omitted and for the vaporized payload to exit the atomizer assembly 19 directly for inhalation.

In some embodiments, a heater or atomizer 20 is disposed in atomizer assembly 19, with atomizer 20 further comprising a heating element 22 disposed therein for heating and vaporizing a payload that may comprise, for example, liquids, oils or other fluids (e.g., cannabis oil or nicotine oil). Vape device 10 may also be modified to vaporize a tablet of dry material or dry material that is not in tablet form (e.g., ground cannabis bud). Heating element 22 may be a heating coil. Atomizer 20 can comprise an inlet 21 and an outlet 23, wherein inlet 21 can be in communication, via fluid connector 46, with payload reservoir 26 disposed in payload assembly 24, wherein payload reservoir 26 can contain a payload for vaporization or atomization. Outlet 23 can be in communication with a user mouthpiece 16 of mouthpiece assembly 12 via a conduit 17, which is typically a hollow tube made of stainless steel, aluminum, or other materials known to those skilled in the art. It will be understood to those skilled in the art that an air path will extend through atomizer assembly 19 and mouthpiece assembly 12 allowing ambient air to flow from an air inlet (not shown) of atomizer 20 and through conduit 17 to user mouthpiece 16.

In some embodiments, payload assembly 24 contains a memory device 28. Memory device 28 may be any type of device that includes memory or storage capable of storing a unique payload identifier that identifies payload reservoir 26 and/or other information related to the payload contained in payload reservoir 26, as discussed below. Memory device 28 also includes means for allowing the stored information to be retrieved by another device. For example, memory device 28 may be wired (e.g., EEPROM or flash memory), wireless (e.g., a radio frequency identification (RFID) tag or near field communications (NFC) tag), or a combination of wired and wireless (e.g., wired through one interface and wireless through another interface). Microcontroller 31 may process the information retrieved from memory

- 13 -

device 28 and/or transmit the information to an external computing device via a radio frequency (RF) transceiver circuit 36 and antenna(s) 40. In one embodiment, memory device 28 comprises an integrated circuit (IC) chip for modulating and demodulating radio frequency signals, such as a galvanically isolated NFC tag that can be read by any NFC-capable device.

5 In one embodiment, the NFC tag is read directly by an external computing device, such as personal computing device 72 described below. Of course, other short-range wireless technologies may also be used in accordance with the present invention.

In some embodiments, atomizer 20 can be disposed in atomizer assembly 19 that can either be integral to mouthpiece assembly 12, or a physically separate enclosure that can couple to mouthpiece assembly 12. Instead of or in addition to including a heating element
10 22 as disclosed herein, atomizer 20 may include any other structure capable of vaporizing or atomizing a payload in a suitable form for inhalation. For example, atomizer 20 may include a jet nebulizer, an ultrasonic nebulizer, or a mesh nebulizer.

In some embodiments, payload reservoir 26 and memory device 28 can be
15 disposed in payload assembly 24 that can either be integral to mouthpiece assembly 12 and/or atomizer assembly 19, or a physically separate enclosure that can couple to mouthpiece assembly 12 and/or atomizer assembly 19, which can include one or more of connecting means 15 described above. Preferably, memory device 28 is physically coupled to payload reservoir 26 either directly or indirectly (e.g., memory device 28 and payload reservoir 26 are included
20 in a common housing of payload assembly 24) in a tamper resistant manner.

In some embodiments, control assembly 14 can comprise one or more antennas 40, a power source such as battery 42, and a printed circuit board 30 that can further comprise a microcontroller 31 configured for carrying out one or more electronic functions in respect of the operation of vape device 10. Having more than one antenna 40 can enable the ability for
25 diversity wireless communications of RF signals, as well known to those skilled in the art. In some embodiments, battery 42 can comprise a lithium ion power cell battery, although other battery technologies can be used as well known to those skilled in the art. As the vape devices are personal use devices, the battery 42 can comprise technology that prevents the advent of an explosion should the battery fail.

In some embodiments, circuit board 30 can comprise a charger circuit 32
30 configured for charging battery 42. Charger circuit 32 can be integral to circuit board 30 or can be disposed on a separate circuit board operatively connected to circuit board 30 and to battery 42 via electrical connection 54. Charger circuit 32 can be configured to be operatively

- 14 -

connected to an external source of power, either via a shared or dedicated electrical connector 35 operatively coupled to circuit board 30 with internal connection to charger circuit 32, or a wireless connection for power transfer, as well known to those skilled in the art. Charger circuit 32 may also connect to electrical connection 50 as a means of charging.

5 In some embodiments, circuit board 30 can comprise user input interface circuit 34 and output interface circuit 38. Either or both of input interface circuit 34 and output interface circuit 38 can be integral to circuit board 30 or can be disposed on a separate circuit board operatively connected to circuit board 30. In some embodiments, input interface circuit 34 can provide the electrical interface between user controls and activation mechanisms
10 disposed on vape device 10, such as buttons, switches, draw sensors, pressure transducers, proximity sensors, flow sensors, touch sensors, voice recognition sensors, haptic controls, saliva and breath biosensors, and the like, and microcontroller 31 and, thus, can provide the means to relay user input commands from the user controls as instructions to microcontroller 31 to operate vape device 10.

15 For example, input interface circuit 34 may be electrically coupled to a draw sensor 18 for receiving an "on" signal from draw sensor 18 when a user draws on mouthpiece 16. When input interface circuit 34 receives the "on" signal from draw sensor 18, it may send instructions to microcontroller 31 to cause supply of a controlled current or voltage to heating element 22 and thereby provide vapor through outlet 23, provided that any other conditions
20 necessary to activate atomizer 20 have been met. In some embodiments, draw sensor 18 comprises a sensor, such as a mass air flow sensor, that can produce an electrical signal in response to when a user inhales or draws on mouthpiece 16, wherein the electrical signal can cause the power signal to flow from battery 42 through heating element 22. In some embodiments, draw sensor 18 can be used as a simple "switch" as a means to turn on atomizer
25 20 to vaporize payload drawn into atomizer 20 from payload reservoir 26 as the user draws on mouthpiece 16. Draw sensor 18 is one type of activation mechanism that may be used to activate atomizer 20. Draw sensor 18 may be replaced with or used in connection with another type of activation mechanism that receives an input to switch it from an "off" position, in which atomizer 20 is not activated, and an "on" position, in which atomizer 20 is activated. For
30 example, draw sensor 18 may be replaced with or used in connection with any of the following types of activation mechanisms: a button, switch, pressure transducer, proximity sensor, flow sensor, touch sensor, voice recognition sensor, haptic control, saliva and breath biosensor, and the like.

- 15 -

In some embodiments, output interface circuit 38 can provide the electrical interface between microcontroller 31 and output display devices, such as indicator lights, alphanumeric display screens, audio speakers, surface heaters, vibration devices, and any other forms of tactile feedback devices as well known to those skilled in the art, and, thus, can provide the means to relay information relating to the operation of vape device 10 from microcontroller 31 to the user.

In some embodiments, circuit board 30 can comprise an RF transceiver circuit 36 to provide the means for wireless communication of data between vape device 10 and a personal computing device, such as personal computing device 72 as shown in FIG. 3. In some embodiments, RF transceiver circuit 36 can be integral to circuit board 30 or can be disposed on a separate circuit board operatively connected to circuit board 30. RF transceiver circuit 36 can be connected to one or more antennas 40 via electrical connection 52, as well known to those skilled in the art. RF transceiver circuit 36 and the one or more antennas 40 comprise a wireless transceiver of vape device 10.

In some embodiments, microcontroller 31 can comprise a microprocessor (which for purposes of this disclosure also incorporates any type of processor) having a central processing unit as well known to those skilled in the art, wherein the microprocessor can further comprise a memory configured for storing a series of instructions for operating the microprocessor in addition to storing data collected from sensors disposed on vape device 10 or data received by vape device 10 to control its operation, such as operational settings. Microcontroller 31 is in electrical communication with charger circuit 32, user input interface circuit 34, output interface circuit 38, and RF transceiver circuit 36 for receiving instructions and/or data from and/or transmitting instructions and/or data to charger circuit 32, user input interface circuit 34, output interface circuit 38, and RF transceiver circuit 36.

In some embodiments, atomizer 20 can be operatively and electrically connected to circuit board 30 via electrical connection 48, which can provide the means to activate atomizer 20 (e.g., deliver electrical current from battery 42 to heating element 22) when an activation mechanism such as draw sensor 18 sends an "on" signal to microcontroller 31, as well as receiving data signals from draw sensor 18 and/or atomizer 20. In this manner, the activation mechanism (i.e., draw sensor 18) is coupled to the atomizer 20 indirectly through microcontroller 31, and a direct connection between the activation mechanism and atomizer 20 is not required (i.e., the activation mechanism sends a signal to microcontroller 31 which sends a signal to activate atomizer 20). In addition to controlling operation of atomizer 20 based on

- 16 -

a signal received from the activation mechanism, microcontroller 31 also controls operation of atomizer 20 based on the operational settings described below. In some embodiments, microcontroller 31 can be operatively connected to memory device 28 via electrical connection 50.

5 As used herein, the term "electrical connection" shall include any form of electrical connection via a wired or wireless connection, such as electrical conductors or wires suitable for the transmission of a power signal (e.g., a direct current or pulsed direct current), analog or digital electrical signals or radio frequency signals, as the case may be and as well-known to those skilled in the art.

10 The operational settings referred to herein include any type of setting or instruction that instructs the vape device 10 or certain components of the vape device 10 to operate or not operate in a particular manner. Specifically, operational settings of the vape device 10 include one or more of a duty cycle setting, a temperature setting, an operational time duration, a dosage setting, and a security setting. The duty cycle setting preferably
15 corresponds to a pulse width modulation instruction transmitted from microcontroller 31 to battery 42 to send electrical current to heating element 22 in a particular desired manner. The temperature setting preferably corresponds to a temperature instruction transmitted from microcontroller 31 to battery 42 to send electrical current to heating element 22 to maintain heating element 22 at a desired temperature or range of temperatures. A temperature sensor
20 may be coupled to microcontroller 31 to measure the actual temperature of heating element 22 and transmit that information to microcontroller 31 for determination of the amount and duration of electrical current that needs to be sent to heating element 22 to maintain a particular temperature or range of temperatures. The operational time duration preferably corresponds to a time instruction transmitted from microcontroller 31 to battery 42 to maintain heating element
25 22 at a temperature suitable for vaporization of the contents of payload reservoir 26 for a desired time. The dosage setting preferably corresponds to a dosage instruction transmitted from microcontroller 31 to battery 42 that powers down heating element 22 when a desired volume of vapor passes through atomizer 20. As described in greater detail below, various dose metering methods may be used to accurately measure the volume of vaporized payload
30 passing through atomizer 20 to mouthpiece 16 for user inhalation, whereby microcontroller 31 compares the actual volume passed through atomizer 20 to the dosage setting to determine when to shut off heating element 22.

- 17 -

In some embodiments, memory device 28 and/or microcontroller 31, along with appropriate sensors, can also be used as part of a system for gathering data relating to the use of vape device 10 by the user by monitoring that can include, without limitation, historical vape device usage information, such as how many times vape device 10 is used during a given period of time (hour, day, week, etc.), the duration of each use of vape device 10, how many draws the user takes on vape device 10, the strength of those draws, the amount of payload consumed during each use of vape device 10, and other information as described herein. The historical vape device usage information may be stored in a database in association with the payload identifier. In some embodiments, the historical vape device usage information can be used as clinical data for determining whether the user is consuming the right amount of medicine to be vaporized and inhaled and at the right times of day. The information can be used to provide feedback to the user in terms of whether the user should consume medicine more frequently or less frequently throughout the day and/or to increase or decrease the amount of medicine consumed per usage overall or per usage at particular times of the day. In some embodiments, the information collected about the user's consumption of a cannabis liquid or oil payload with vape device 10 can be used to estimate the user's intoxication or impairment based on the user's physical characteristics and the amount of cannabis liquid or oil payload consumed. This estimation can be relayed to the user as a means to inform the user as to whether the user is too intoxicated or impaired to operate a motor vehicle or to operate tools or machinery, as an example.

Second Embodiment of Vape Device

Referring to FIG. 2, a second embodiment of a vape device is shown generally as reference numeral 100. In some embodiments, vape device 100 can comprise control assembly 14, atomizer assembly 79 and mouthpiece assembly 88 operatively coupled together in that order using mechanical connection means 56 to join the subassemblies together. Mechanical connection means 56 can comprise one or more of threaded connection means, magnetic connection means and friction or press-fit connection means, and any of the connection means 15 described above, including 510 threaded connectors. In some embodiments, mouthpiece assembly 88 can comprise a mouthpiece 58 in communication with the outlet of atomizer 20 via conduit 60, which is typically a hollow tube made of stainless steel, aluminum, or other materials known to those skilled in the art. Mouthpiece assembly 88 can further comprise a payload reservoir 62 that can be filled with a payload 64 that may be liquid or oil. The payload 64 can flow from payload reservoir 62 to inlet 21 of atomizer 20 via

- 18 -

one or more valves 68. In some embodiments, mouthpiece assembly 88 can comprise memory device 28 and an oil gauge 66, which can be configured to monitor the volume of payload 64 in payload reservoir 62 and relay that information to microcontroller 31. In this embodiment, mouthpiece assembly 88 can be a consumable element that can be replaced as a complete subassembly once depleted, or simply interchanged with another mouthpiece assembly 88 containing a different payload 64 for consumption, depending on the needs and wants of the user. In some embodiments, oil gauge 66 can simply be a sight glass disposed on mouthpiece assembly 88 to provide a visual indicator to the user as to the amount of payload remaining therein. Atomizer assembly 79 is preferably configured to prevent air-lock and/or clogging with thick, undiluted payloads. It will be understood to those skilled in the art that an air path will extend through atomizer assembly 79 allowing ambient air to flow from an air inlet (not shown) of atomizer 20 and through conduit 60 to mouthpiece 58.

Control assembly 14 of vape device 100 is preferably substantially similar to control assembly 14 of vape device 10. Atomizer 20 of vape device 100 is preferably substantially similar to atomizer 20 of vape device 10, and may include alternative means for vaporizing a payload other than a heating element as described above in connection with vape device 10. It is within the scope of the invention for atomizer assembly 79 and mouthpiece assembly 88 to be formed integrally within a common housing that is releasably connected to control assembly 14. Further, it is within the scope of the invention for control assembly 14 and atomizer assembly 79 to be formed integrally within a common housing that is releasably connected to mouthpiece assembly 88. It is also within the scope of the invention for atomizer assembly 79, mouthpiece assembly 88, and control assembly 14 to be formed integrally within a common housing.

Vape Device Application

Referring to FIG. 3, one embodiment of a vape device system 102 includes vape device 10 and a personal computing device 72 running application 74 thereon. It is understood that personal computing device 72 includes a processor 94 that runs application 74, and that references herein to personal computing device 72 include its processor 94. Vape device 100 may also be operated with personal computing device 72 in the same manner as described below with respect to vape device 10.

As used herein, the term "personal computing device" is defined as including personal computers, laptop computers, personal digital assistants, personal computing tablets (such as those made by Apple® and Samsung®, and by others as well known to those skilled

- 19 -

in the art), smart phones (such as those running on iOS® and Android® operating systems, and others as well known to those skilled in the art), smart watches, fitness tracking wristbands, wearable devices, smart glasses, and any other electronic computing device that comprises means for communication (wireless or wired) with other electronic devices, and with a global telecommunications or computing network.

In some embodiments, vape device 10 can wirelessly communicate with personal computing device 72 and application 74 via RF communications link 73. In some embodiments, RF communications link 73 can comprise one or more of Bluetooth™ communications protocol, Wi-Fi™ IEEE 802 communications protocol, Zigbee IEEE 802.15.4-based protocol, and any other RF, short-range, and long-range communications protocol as well known to those skilled in the art. Vape device 10 may also communicate with personal computing device 72 via a wired connection established, for example, between electrical connector 35 of vape device 10 and a communications connector (not shown) of personal computing device 72.

Vape device 10 can preferably communicate with personal computing device 72 and operate in conjunction with application 74 to control and monitor the use of vape device 10. In some embodiments, application 74 can be configured to acquire specific information on the payload being vaporized (described below) based on the serial number of the cartridge. In some embodiments, application 74 can access an online source of data to acquire this information, which can be done periodically and/or automatically, or manually by the user prompting the application to update the information, or a combination of both processes. This information can then be used to control or meter the dose of vapor inhaled by the user, as described below.

In some embodiments, computing device 72 transmits the unique payload identifier to a remote computing device at a central server or in the cloud. The remote computing device may maintain a database of operational settings that are associated with each unique payload identifier and tailored to the particular substance located in the payload reservoir and/or the particular user using the payload reservoir. The remote computing device may then send the operational settings and identification of the specific substance within the payload reservoir back to the computing device 72. The historical vape device usage information described above may also be transmitted to and maintained by the remote computing device at the central server or in the cloud.

- 20 -

In some embodiments, application 74 can present a visual "dashboard" 75 comprising visual information and controls that can be operated by a user. In some embodiments, dashboard 75 can comprise user information window 76 for displaying information regarding the operation of vape device 10 in addition to general information. This
5 general information can include general news as well as information on available updates for vape device 10 or the application 74 from the manufacturer or supplier of the same.

In some embodiments, dashboard 75 can comprise a locate button 78 as a means for the user to determine the location of vape device 10 should the user misplace it. By pressing locate button 78, personal computing device 72 can send a signal wirelessly to vape device 10
10 to operate an audible signal from an audio speaker or buzzer or other like device disposed thereon to assist the user in finding vape device 10. In other embodiments, pressing locate button 78 can assist the user to determine his or her geographic location (using geographic location capabilities of personal computing device 72) and whether cannabis products can be consumed using vape device 10 in that location (e.g., whether there are any governmental
15 regulations, laws, or rules applicable to or enforceable in the geographic area where vape device 10 is located that may subject the user of vape device 10 to criminal or administrative penalties, fines, or enforcement actions). In some embodiments, dashboard 75 can comprise heat swipe button 80 as a means for the user to manually control the heat used to vaporize payload 64, wherein the signal transmitted by application 74 to vape device 10 to control the heat can be
20 included in the operational settings. In some embodiments, dashboard 75 can comprise lock indicator 82, unlock indicator 84 and swipe button 86 as a means to enable and disable vape device 10 by the user swiping swipe button 86 right or left, respectively.

II. Dose Metering Methods

The vape device as described above may use four different methods,
25 independently or in any combination, to measure the portion of the payload that is vaporized during each user inhalation and thereby determine the dose of vaporized payload delivered to the user. The first method tracks the energy used to vaporize the payload portion during user inhalation in order to determine the mass of the vaporized payload; the second method measures the temperature at multiple locations within the air flow chamber during user
30 inhalation to determine the vapor density and by extension the mass of the vaporized payload; the third method measures the intensity of light that is transmitted through the vaporized payload, reflected off the vaporized payload, or transmitted through a light transmitting medium positioned within the vaporized payload, during user inhalation to determine the vapor

- 21 -

density and by extension the mass of the vaporized payload; and the fourth method utilizes hot wire anemometers to determine the mass of the vaporized payload that was delivered to the user during each user inhalation and/or to determine the size and density distribution of the droplets in the vaporized payload and use such distribution to calculate the total mass of the vaporized payload that was delivered to the user during each user inhalation. Each of these methods will be described below in connection with the exemplary vape devices shown in FIGS. 4-15.

It should be understood that the exemplary vape devices shown in FIGS 4-15 are illustrated schematically in order to describe the sensors and other components that may be used to implement the various methods. These schematic diagrams and are not intended to illustrate any particular structural configurations for the vape devices, which will vary depending on the type of vape device that implements the disclosed methods. For example, the atomizer of the vape device may be suspended in a conduit and in fluid communication with the payload from a payload reservoir, or, the atomizer of the vape device may be suspended in a portion of the conduit allowing ambient air from the inlet to flow through the atomizer. The conduit may have a cross-section that is circular, rectangular, or any other shape. The various structural configurations for the cartridge, payload reservoir, conduit, etc. will be apparent to those skilled in the art.

In some embodiments, the vape device is also configured to determine the aggregated amount of payload that has been vaporized during previous user inhalations. This amount may be subtracted from the total amount of payload prior to any vaporization to determine the remaining amount of payload in the payload reservoir. Also, because there will be some residual payload in the payload reservoir, the vape device may also be configured to determine the portion of the remaining amount of payload in the payload reservoir that is useable for vaporization—e.g., based on characterization data or testing of samples to determine a mean and range of useable payload with a specified measure of accuracy. Further, the vape device may be configured to provide a notice to the user (e.g., via personal computing device 72) when the remaining amount of payload in the payload reservoir is below a minimum level so that the user may take appropriate steps to refill the payload reservoir or obtain a replacement cartridge.

- 22 -

Energy Usage Method

In some embodiments, the vape device is configured to track the energy used to vaporize a portion of the payload during user inhalation in order to determine the mass of vaporized payload that was delivered to the user during each user inhalation.

5 Referring to FIG. 4, an example of a vape device that relies on the energy usage method to determine the dose of vaporized payload is shown generally as reference numeral 400. Vape device 400 includes a control assembly 410 and a cartridge 420 that may be formed in separate housings that are releasably connected to each other via an electromechanical connection 440. In this embodiment, control assembly 410 is provided as a re-useable
10 component that can be used with multiple disposable cartridges, such as cartridge 420. In other embodiments, control assembly 410 may be disposable, or, the components of control assembly 410 and cartridge 420 may be provided as a self-contained vape device.

Electromechanical connection 440 is configured to provide a mechanical and electrical connection between control assembly 410 and cartridge 420. For example,
15 electromechanical connection 440 may comprise a female 510 threaded connector on control assembly 410 that releasably engages a male 510 threaded connector on cartridge 420. Of course, the invention is not limited to the use of 510 threaded connectors and other types of connectors may also be used, as described above.

As shown in FIG. 4, control assembly 410 includes a power source 412, a
20 microcontroller 414, an RF transceiver circuit 416, and one or more antennas 418. Also, cartridge 420 includes a payload reservoir 422, an atomizer 424, one or more temperature measurement circuits 426 (optional), one or more pressure measurement circuits 428 (optional), and a memory device 430 (optional). Of course, it should be understood that all or a portion of temperature measurement circuits 426 and/or pressure measurement circuits 428
25 may alternatively be located within control assembly 410. Most of these components (with the exception of the temperature and pressure measurement circuits) are described above in connection with vape devices 10 and 100. Of course, it should be understood that control assembly 410 and cartridge 420 may include a number of other components that are not specifically shown in FIG. 4, as also described above in connection with vape devices 10 and
30 100.

With respect to vape device 400, microcontroller 414 is programmed to control power source 412 (e.g., a battery) so that power source 412 transmits a power signal (e.g., a direct current or pulsed direct current) to atomizer 424 in accordance with desired operational

- 23 -

settings. When the heating element of atomizer 424 reaches the vaporization temperature of the payload contained in payload reservoir 422, a portion of the payload is vaporized to thereby generate a vaporized payload for user inhalation. As described below, if the amount of energy required to vaporize the total mass of the payload in payload reservoir 422 is known (i.e., the total mass of the payload prior to any vaporization), microcontroller 414 is able to interpolate from the amount of energy used in each user inhalation the partial mass of payload that has been vaporized during the user inhalation.

For example, consider a payload having a total mass of 0.5 grams (assuming a density of 1 gram/milliliter) that is known to require 1.240 watt-hours of energy to be fully vaporized. If a particular user inhalation were to use 6.179 milliwatt-hours of energy (e.g., 2 amperes of current at 3.7 volts for 3 seconds), this energy usage would comprise approximately 1/200th of the energy required for the total payload. Thus, it is possible to estimate that the partial amount of payload that was vaporized during the user inhalation was 0.0025 grams (i.e., 0.5 grams/200).

In some embodiments, microcontroller 414 is programmed to determine the dose of payload that is vaporized during each user inhalation by performing the following steps: (1) determining the amount of energy used to vaporize a portion of the payload during each user inhalation; and (2) using the amount of energy to determine the partial mass of the payload that is vaporized during the user inhalation. Each of these steps will be described in greater detail below.

It should be understood that the amount of energy used to vaporize a portion of the payload may be associated with the partial mass of the payload using characterization data for the particular payload (e.g., data that has been obtained through testing to correlate the amount of energy to the partial mass). In some embodiments, microcontroller 414 acquires this information from memory device 430, i.e., the characterization data is stored in memory device 430 by the manufacturer of cartridge 420. In other embodiments, microcontroller 414 acquires a unique payload identifier from memory device 430 and transmits the unique payload identifier to personal computing device 72 via RF transceiver 416 and antenna(s) 418. The unique serial number may comprise, for example, a serial number of cartridge 420. The application 74 running on personal computing device 72 may then acquire the characterization data based on the unique payload identifier. In some embodiments, application 74 can access an online source of data to acquire this information. Of course, the payload identifier stored in memory device 430 need not comprise a unique identifier, in which case cartridges containing

- 24 -

the same type and amount of payload could all store the same payload identifier in their respective memory devices. In all of these cases, computing device 72 transmits the acquired information back to microcontroller 414 via RF transceiver 416 and antenna(s) 418. In yet other embodiments in which the vape device comprises a self-contained vape device, the characterization data may be stored on microcontroller 414 itself.

Microcontroller 414 determines the amount of energy used to vaporize a portion of the payload during each user inhalation by determining the amount of power provided to atomizer 424 during the user inhalation, determining the duration of the user inhalation, and then calculating the total amount of energy based on this information (i.e., $E = P \times t$). In some embodiments, microcontroller 414 is programmed to determine the amount of power provided to atomizer 424 by measuring the output voltage of power source 414, measuring the current delivered to atomizer 424, and then calculating the power based on this information (i.e., $P = V \times I$). In other embodiments, microcontroller 414 is programmed to determine the amount of power provided to atomizer 424 by measuring the resistance of the path between power source 412 and atomizer 424, measuring either the output voltage of power source 414 or the current delivered to atomizer 424, and then calculating the power based on this information (i.e., $P = I^2 \times R = V^2 / R$).

In some embodiments, the step of determining the amount of energy used to vaporize a portion of the payload during each user inhalation may be further refined (optionally) by determining the air flow rate within the air flow chamber, and then adjusting the total amount of energy calculated above to account for the air flow rate and its effect on removing heat from atomizer 424. The air flow chamber extends between an inlet and an outlet, and atomizer 424 is positioned between the inlet and outlet such that (1) ambient air flows through the air flow chamber from the inlet to atomizer 424 and (2) air mixed with vaporized payload flows through the air flow chamber from atomizer 424 to the outlet (which may be in communication with a mouthpiece). Those skilled in the art will appreciate that increasing the air flow rate will pull more vapor (and by extension heat) away from atomizer 424 thereby causing the control loop to add more energy into the heating element to maintain a constant temperature. Including the effect of the air flow rate using a direct air flow measurement will increase the accuracy of the dose measurement.

In some embodiments, microcontroller 414 is programmed to determine the air flow rate within the air flow chamber based on a pressure difference across an orifice positioned anywhere in the sealed path between the inlet and outlet of the air flow chamber and the known

cross-sectional area of the orifice. As described below, there are different ways to determine the pressure differential across the orifice using one or more pressure sensors incorporated within pressure measurement circuit(s) 428.

In one embodiment, a first pressure sensor is located on one side of the orifice
5 and a second pressure sensor is located on the opposing side of the orifice. The first pressure sensor is incorporated into a first pressure measurement circuit configured to obtain a plurality of pressure measurements during user inhalation. Similarly, the second pressure sensor is incorporated into a second pressure measurement circuit configured to obtain a plurality of pressure measurements during user inhalation. Thus, the pressure difference across the orifice
10 during user inhalation is based on the pressure measurements obtained by the first and second pressure measurement circuits during user inhalation.

In another embodiment, a single pressure sensor is located on one side of the orifice. The pressure sensor is incorporated into a pressure measurement circuit configured to obtain a plurality of pressure measurements before and during user inhalation, e.g., one or more
15 ambient pressure measurements before the draw in which the pressure is equal on either side of the orifice followed by other pressure measurements during the draw in which there is a partial vacuum on the side of the orifice where the pressure sensor is located. Thus, the pressure difference across the orifice during user inhalation is based on the pressure measurements obtained by the pressure measurement circuit before and during user inhalation.

In another embodiment, a single pressure sensor is located on one side of the orifice. The pressure sensor is incorporated into a pressure measurement circuit configured to obtain a plurality of pressure measurements during and after user inhalation, e.g., pressure
20 measurements during the draw in which there is a partial vacuum on the side of the orifice where the pressure sensor is located followed by one or more ambient pressure measurements after the draw in which the pressure is equal on either side of the orifice. Thus, the pressure difference across the orifice during user inhalation is based on the pressure measurements obtained by the pressure measurement circuit during and after user inhalation.

In yet another embodiment, a single pressure sensor is located on one side of the orifice. The pressure sensor is incorporated into a pressure measurement circuit configured
30 to obtain a plurality of pressure measurements before, during and after user inhalation, e.g., a combination of the above two embodiments, such that the ambient pressure measurements before and after the draw are used and compared to the partial vacuum measurements during the draw. Thus, the pressure difference across the orifice during user inhalation is based on the

- 26 -

pressure measurements obtained by the pressure measurement circuit before, during and after user inhalation.

In some embodiments, the step of determining the amount of energy used to vaporize a portion of the payload during each user inhalation may be further refined (optionally) by determining the amount of energy used to heat atomizer 424 to the vaporization temperature, and then adjusting the total amount of energy calculated above by subtracting or omitting that portion of the total energy. In order to determine when atomizer 424 has reached the vaporization temperature, a temperature sensor incorporated into temperature measurement circuit 426 may be used to sense the temperature within cartridge 420. Various examples of temperature sensors that may be used in temperature measurement circuit 426 are described below.

In general, the temperature sensor may comprise any type of component capable of sensing the temperature within cartridge 420. For example, temperature sensor 426 may comprise a thermistor, a thermocouple, a bandgap temperature sensor, an analog temperature sensor, a digital temperature sensor (e.g., temperature sensors with I2C interface compatibility), or any other type of temperature sensor known to those skilled in the art. The thermal path between atomizer 424 and the temperature sensor may be implemented with thermal paste, a ceramic thermal bridge (e.g., the Q-Bridge thermal conductor available from American Technical Ceramics), or air and PCB dielectric.

The temperature sensor may also comprise a light sensor configured to detect light emitted from a material within cartridge 420, wherein the intensity of the emitted light is proportional to the temperature of the material, as is known to those skilled in the art. The light sensor may comprise, for example, a photodiode or phototransistor that detects light emitted by the heating element and/or light emitted by the vaporized payload (which would typically be in the infrared region of 0.7 microns to 20 microns). The light sensor is preferably able to detect the light through different seals or glass so that the light sensor can be isolated from the vaporized payload.

The temperature sensor may also comprise a circuit configured to measure the resistance of the heating element and utilize this measurement to determine the temperature within cartridge 420. As is known in the art, the resistance of the heating element is directly proportional to the resistivity of the material from which the heating element is made (i.e., the resistance is dependent on the resistivity, length, and cross-sectional area of the heating element). The relationship between the resistivity of the heating element and temperature is

shown by the following equation (which is a linear approximation for cases in which the temperature variance is not large):

$$\rho = \rho_0(1 + \alpha(T - T_0)) \tag{1}$$

where

- 5 ρ = resistivity of heating element at temperature T in ohm meters;
- ρ_0 = resistivity of heating element at temperature T_0 in ohm meters;
- α = temperature coefficient of resistivity at T_0 ;
- T = current temperature in °K; and
- T_0 = fixed reference temperature (e.g., ambient temperature) in °K.

10 It can be seen from equation (1) that the resistivity of the heating element increases with an increase in the current temperature of the heating element. Thus, if the resistance of the heating element is known at any given moment, it is possible to calculate the resistivity of the heating element and, using equation (1), calculate the current temperature of the heating element.

15 For example, the following method may be implemented to determine the current temperature of the heating element (and thus the temperature within cartridge 420): (a) measure the ambient temperature within cartridge 420 (the heating element will be approximately the same temperature provided it has not been activated recently); (b) periodically measure the resistance of the heating element while the heating element is being
 20 powered; and (c) calculate the current temperature of the heating element based on the measured resistance (or determine a change in the resistance of the heating element to provide the temperature increase above the ambient temperature value). Thus, the resistance of the heating element as a function of temperature can be used to provide an accurate assessment of the temperature within cartridge 420 at any given moment.

25 In addition, in some embodiments, the step of determining the amount of energy used to vaporize a portion of the payload during each user inhalation may be further refined (optionally) by adjusting the total amount of energy calculated above to account for one or more operating conditions, such as those listed in Table 1 below:

Operating Condition	Impact on Energy
starting temperature of vape device	The starting temperature of the vape device's materials (e.g., the housing, battery, payload reservoir, etc.) will impart a baseline temperature to the volume of air in the vape device.

- 28 -

starting temperature of payload	The payload temperature determines the starting point from which the payload must be heated. The colder the payload, the more energy must be supplied to the atomizer before the payload will begin to vaporize.
temperature of ambient air	The ambient air drawn into the inlet during an inhale will bring with it an amount of heat energy that will offset the air at the outlet. The colder the ambient air, the less it is expected that the air at the outlet will increase. The warmer the ambient air, the more it is expected that the air at the outlet will increase.
relative humidity of ambient air	The ambient relative humidity changes the specific heat capacity of the ambient air, making it require more or less energy to impart the same temperature change.
pressure of ambient air	Ambient pressure is used to determine the flow rate of the air through the orifice. The ambient pressure occurs on one side of the orifice and the inhale pressure occurs on the other side of the orifice. It is the difference between these two that can be used to determine the flow rate.
output voltage of power source	As the battery voltage changes through normal use, the maximum amount of power that can be put into the atomizer is reduced.
temperature ramp rate of atomizer	This operating condition can be used to determine the thermal mass in thermal communication with the heating element. This information can be used to determine how much payload is present and available for vaporization.

Table 1

As discussed above, microcontroller 414 uses the amount of energy calculated above to determine the partial mass of the payload that is vaporized during user inhalation. In some embodiments, this step may be further refined (optionally) to determine the mass of each of the components within the payload that are vaporized during user inhalation (assuming that the payload and its constituent components and relative percentages are known). For example, assume that the payload includes known percentages of CBD and THC, wherein CBD vaporizes at 150°C (i.e., the boiling point of CBD) and THC vaporizes at 178°C (i.e., the boiling point of THC). Microcontroller 414 can predict the relative amounts of CBD and THC

- 29 -

vaporized at temperatures of 140°C, 160°C, 180°C, etc., to provide specific information on the dose of CBD and THC delivered to the user during user inhalation. Further, microcontroller 414 may optionally determine an optimal vaporization temperature for the payload based on the relative percentage and boiling point for each of the components within the payload.

5 Finally, it should be understood that all or a portion of the processing steps performed by microcontroller 414, as described above, could alternatively be performed by one or more other microcontrollers, such as a secondary microcontroller (not shown) positioned in cartridge 420. For example, in some embodiments, a secondary microcontroller positioned in cartridge 420 is programmed to determine the amount of energy delivered to atomizer 424
10 during each user inhalation and then transmit this information to microcontroller 414 over the electrical interface between cartridge 420 and control assembly 410. In this case, microcontroller 414 would perform all of the other steps described above. In other embodiments, a secondary microcontroller positioned in cartridge 420 is programmed to perform all of the steps described above and then transmit the dose of the vaporized payload to
15 microcontroller 414 over the electrical interface between cartridge 420 and control assembly 410. In yet other embodiments, personal computing device 72 is programmed to perform a portion of the steps described above, assuming that the appropriate information is passed from the vape device to personal computing device 72. Further, in some embodiments, a secondary microcontroller positioned in cartridge 420 is configured by microcontroller 414 positioned in
20 control assembly 410 or, alternatively, the secondary microcontroller uses operational settings stored in memory device 430 to determine when to stop atomizer 424 so as to deliver a full dose (wherein the full dose may also be stored in memory device 430). Of course, those skilled in the art will appreciate that the steps performed by microcontroller 414 and any secondary microcontroller will vary between different applications.

25 ***Temperature Measurement Method***

In some embodiments, the vape device is configured to measure the temperature at multiple locations within the air flow chamber during user inhalation (and optionally before and after user inhalation) to determine the vapor density and by extension the mass of vaporized payload that was delivered to the user during each user inhalation.

30 Referring to FIG. 5, an example of a vape device that relies on the temperature measurement method to determine the dose of vaporized payload is shown generally as reference numeral 500. Vape device 500 includes a housing 502, which may comprise an internal housing or external housing of vape device 500. Positioned within housing 502 is an

- 30 -

air flow chamber which, in this example, comprises a conduit 512 that extends between an inlet 504 and an outlet 506. It can be appreciated that the inlet and outlet orifices are defined by conduit 512. An atomizer 510 is positioned anywhere between inlet 504 and outlet 506. As described above, atomizer 510 is configured to heat and vaporize the payload contained in a payload reservoir (not shown) so as to output a vaporized payload. During a user inhalation, ambient air flows through conduit 512 from inlet 504 to atomizer 510, and ambient air mixed with vaporized payload flows through conduit 512 from atomizer 510 to outlet 506. Outlet 506 may further be in communication with a mouthpiece, as described above. Of course, it should be understood that vape device 500 may include a number of other components that are not specifically shown in FIG. 5, including a power source, a microcontroller, and other electronics, as described above in connection with vape devices 10 and 100.

With respect to vape device 500, the microcontroller is programmed to control the power source (e.g., a battery) so that the power source transmits a power signal (e.g., a direct current or pulsed direct current) to atomizer 510 in accordance with desired operational settings. When the heating element of atomizer 510 reaches the vaporization temperature of the payload contained in the payload reservoir, a portion of the payload is vaporized to thereby generate the vaporized payload for user inhalation. As described below, the vaporized payload transfers a significant amount of heat from atomizer 510 to the air that is flowing through conduit 512 to outlet 506—significantly more so than air alone. There are key locations in the air path within conduit 512—i.e., a location between inlet 504 and atomizer 510 and one or more locations between atomizer 510 and outlet 506—where temperature measurements can provide valuable information.

In this example, vape device 500 includes three temperature sensors. Specifically, a first temperature sensor 514 is located within conduit 512 between inlet 504 and atomizer 510, wherein first temperature sensor 514 is incorporated into a first temperature measurement circuit configured to obtain a plurality of temperature measurements during user inhalation (and optionally before and after user inhalation). Also, a second temperature sensor 516 is located within conduit 512 between atomizer 510 and outlet 506 (relatively close to atomizer 510), wherein second temperature sensor 516 is incorporated into a second temperature measurement circuit configured to obtain a plurality of temperature measurements during user inhalation (and optionally before and after user inhalation). In addition, a third temperature sensor 518 is located within conduit 512 between atomizer 510 and outlet 506 (close to outlet 506), wherein third temperature sensor 518 is incorporated into a third

- 31 -

temperature measurement circuit configured to obtain a plurality of temperature measurements during user inhalation (and optionally before and after user inhalation).

Each of temperature sensors 514, 516 and 518 may comprise any type of component capable of sensing the temperature at the designated locations, such as a thermistor, a thermocouple, an infrared sensor, a bandgap temperature sensor, an analog temperature sensor, or a digital temperature sensor. Of course, those skilled in the art will understand that other types of temperature sensors may be used in accordance with the present invention.

Using the measured temperatures and the relative temperature changes between temperature sensors 514, 516 and 518 in conjunction with the air flow rate within conduit 512 (which may be determined using one or more pressure measurement circuits, such as pressure measurement circuit(s) 428 described above in connection with FIG. 4), it is possible to determine the amount of vaporized payload required to transfer the heat energy throughout the air path. Specifically, the vaporized payload has a specific heat capacity and carries heat away from atomizer 510 and towards outlet 506. As more vapor is created, more heat energy will be transferred downstream. Given a fixed, non-zero air flow rate, the temperature within conduit 512 between atomizer 510 and outlet 506 will be higher than the temperature within conduit 512 between inlet 504 and atomizer 510. Likewise, for a fixed amount of vapor, there will be a lower temperature rise for higher air flow rates because there is more ambient air mixed with the vaporized payload thereby reducing the amount of heat being transferred within conduit 512 from atomizer 510 to outlet 506. Thus, through characterization over various operating conditions, an accurate estimate of the vapor density of the vaporized payload can be determined. Using the vapor density and the air flow rate over time, it is possible to determine the mass of payload that was vaporized for user inhalation and by extension the dose that the user received.

Thus, in some embodiments, the microcontroller of vape device 500 is programmed to determine the dose of payload that is vaporized during each user inhalation by performing the following steps: (1) acquiring a plurality of temperature measurements obtained at various locations within the air flow chamber during user inhalation (and optionally before and after user inhalation); (2) determining the air flow rate within the air flow chamber during user inhalation; and (3) using the information from steps 1 and 2 to determine the vapor density of the vaporized payload and by extension the partial mass of the payload that is vaporized during user inhalation.

- 32 -

In some embodiments, the method may be further refined (optionally) by using a thermistor as part of one or more of the temperature measurement circuits. The thermistor may be biased to a more sensitive operating region by passing current (direct current or pulsed direct current) such that it self-heats the thermistor. By tracking the amount of current increase required to keep the thermistor at the same temperature, an estimate of the air flow rate, vapor density, etc., may be determined using characterization data.

In some embodiments, the method may be further refined (optionally) by accounting for the air moisture content and atmospheric pressure within the air flow chamber prior to vaporization, e.g., within conduit 512 between inlet 504 and atomizer 510. These operating conditions will alter the rate at which the temperature changes throughout the air flow path.

Finally, it should be understood that all or a portion of the processing steps performed by the microcontroller of vape device 500, as described above, could alternatively be performed by one or more other microcontrollers, such as a secondary microcontroller (not shown) positioned in a cartridge of vape device 500 (for embodiments in which vape device 500 comprises a cartridge releasably connected to a control assembly). Various embodiments will be apparent to those skilled in the art.

Light Intensity Measurement Methods

Various examples of vape devices that utilize different light intensity measurement methods will be described below. In each of these examples, the vape device includes at least one light sensor comprised of a light source and a light detector. The light source may comprise, for example, a light emitting diode (LED), a laser, or an incandescent lamp, although other types of light sources may also be used. The light detector may comprise, for example, a photo-diode, although other types of light detectors may also be used.

The characteristics of the light emitted by the light source for detection by the light detector will vary between different applications. The wavelength of the emitted light may fall in the visible or invisible (ultraviolet or infrared) portions of the electromagnetic spectrum. The emitted light may be continuous, or the light may be pulsed, for example, to save power or to take successive light intensity measurements. The pulsing is preferably scaled to reflect the air flow rate.

As discussed below, the light source and light detector are incorporated into a light intensity measurement circuit configured to obtain a plurality of light intensity measurements during each user inhalation (and optionally before and after user inhalation) and

provide such measurements to the microcontroller of the vape device. Preferably, the characterization data used by the microcontroller to determine the vapor density based on the light intensity measurements will account for the vapor density changing with temperature and air flow rate.

5 In some examples, the light sensor is a reflective sensor in which the light source is configured to emit light that is directed toward the path of the vaporized payload and the light detector is configured to detect the light reflection from the vaporized payload (such as the light sensor incorporated into the vape device shown in FIG. 6). When the vapor density of the vaporized payload increases, the light reflection from the vaporized payload increases.
10 Conversely, when the vapor density of the vaporized payload decreases, the light reflection from the vaporized payload decreases. These properties can be utilized to determine the vapor density of the vaporized payload.

 With a reflective sensor, the wavelength of the emitted light may be selected so that the light is maximally reflected by the vaporized payload. The intensity of the emitted
15 light is preferably low enough so that the reflected light does not overwhelm the light detector. In some embodiments, the light intensity is ramped over a very short time period (but slow enough that the photo-diode is able to track it) in order to identify the point at which the photo-diode begins to saturate. The photo-diode will saturate earlier if the vaporized payload has a higher vapor density and is more reflective. In some embodiments, the light intensity is
20 dynamically modified based on the measured vapor density of the vaporized payload.

 In other examples, the light sensor is a transmissive sensor in which the light source is configured to emit light that is directed toward the path of the vaporized payload and the light detector is configured to detect light transmission through the vaporized payload (such as the light sensors incorporated into the vape devices shown in FIGS. 7-10). When the vapor
25 density of the vaporized payload increases, the light transmission through the vaporized payload decreases. Conversely, when the vapor density of the vaporized payload decreases, the light transmission through the vaporized payload increases. These properties can be utilized to determine the vapor density of the vaporized payload.

 With a transmissive sensor, the wavelength of the emitted light may be selected
30 so that the light is maximally absorbed by the vaporized payload. The intensity of the emitted light is preferably high enough to result in some light reaching the light detector. In some embodiments, the light intensity is ramped over a very short time period (but slow enough that the photo-diode is able to track it) in order to identify the point at which the photo-diode begins

- 34 -

to saturate. The photo-diode will saturate earlier if the vaporized payload has a lower vapor density. In some embodiments, the light intensity is dynamically modified based on the measured vapor density of the vaporized payload.

In yet other examples, the light source is configured to emit light that is directed
5 toward a light transmitting medium positioned within the path of the vaporized payload and the light detector is configured to detect light transmitted through the medium (such as the light sensors incorporated into the vape devices shown in FIGS. 11-13). The light transmitting medium is made of glass, plastic or another material with an index of refraction that is sufficiently similar to that of the payload and sufficiently different from that of air.

10 When the surface of the light transmitting medium is surrounded entirely by air prior to any use of the vape device, most of the light emitted by the light source will travel through the medium to the light detector. Notably, when the light impacts the medium/air boundary at an angle, the light will totally reflect back into the medium (i.e., total internal reflection) due to the differences between the index of refraction of the medium and the index
15 of refraction of air. Thus, the light detected by the light detector will have substantially the same intensity as the light emitted by the light source.

However, when vaporized payload, e.g., an oil droplet, is deposited on the surface of the light transmitting medium during use of the vape device, some of the light traveling through the medium will impact the medium/payload boundary at an angle and escape
20 the medium into the deposited payload due to the similarities between the index of refraction of the medium and the index of refraction of the payload. Thus, the level of attenuation of the light received by the light detector will be dependent on the total amount of payload deposited on the surface of the medium.

It should be understood that the light transmission through the medium will
25 decrease as the medium becomes increasingly fouled (coated) with droplets from the vaporized payload over the lifetime of the medium—i.e., there will be residual payload deposited on the surface of the medium after each user inhalation. Light intensity measurements are preferably obtained before, during, and after each user inhalation, and the rate of decrease of light transmission through the medium indicates the amount of vaporized payload that has passed
30 the medium during that user inhalation. These properties can be utilized to determine the vapor density of the vaporized payload. Because the light transmitting medium has a limited lifetime, it is preferably placed in a replaceable cartridge portion of the vape device.

- 35 -

With this type of light sensor, the intensity of the emitted light is preferably increased over the lifetime of the light transmitting medium. When the medium is clean, very little of the emitted light will escape the medium due to total internal reflection at the medium/air boundary. As such, the emitted light can have a low intensity and still be detectable at the light detector. However, as droplets from the vaporized payload successively collect on the outside surface of the light transmitting medium throughout the lifetime of the medium, more light will escape the medium at the medium/payload boundary. As such, the emitted light must have a higher intensity to be detectable at the light detector.

The material of the light transmitting medium may be selected to obtain a desired index of refraction and associated effect. Those skilled in the art will appreciate that the critical angle is the smallest angle of incidence that yields total internal reflection through a light transmitting medium, as shown by the following equation:

$$\theta_c = \arcsin(n_2 / n_1) \quad (2)$$

where

θ_c = critical angle in degrees;
 n_1 = index of refraction of light transmitting medium; and
 n_2 = index of refraction of material adjacent to light transmitting medium (e.g., the droplets from the vaporized payload).

The closer the indexes of refraction are between the light transmitting medium and the droplets from the vaporized payload, the more likely it will be that the light escapes the medium into one of the droplets. In some embodiments, the index of refraction of the light transmitting medium is selected so as to be substantially the same as the index of refraction of the vaporized payload so as to maximize the amount of escaped light. In other embodiments, the index of refraction of the light transmitting medium is selected so as to be slightly different than the index of refraction of the vaporized payload so as to limit the amount of escaped light, which may be beneficial in cases where it is desired to limit the amount of attenuation at the light detector. In other embodiments, the payload is modified via the use of additive(s) so as to obtain a desired index of refraction, although this approach is not preferred insofar as any such additive(s) may be inhaled by the user—i.e., it is preferred to modify the index of refraction of the light transmitting medium.

Of course, other vape devices may include any combination of the foregoing types of light sensors. For example, a vape device may include both a reflective sensor and a

- 36 -

transmissive sensor that are used either simultaneously or sequentially to switch between the reflective and transmissive modes (depending on which mode provides better dynamic range).

Referring to FIG. 6, a first example of a vape device that relies on a light intensity measurement method to determine the dose of vaporized payload is shown generally as reference numeral 600. Vape device 600 includes a housing 602, which may comprise an internal housing or external housing of vape device 600. Positioned within housing 602 is an air flow chamber which, in this example, comprises a conduit 612 that extends between an inlet 604 and an outlet 606. It can be appreciated that the inlet and outlet orifices are defined by conduit 612. An atomizer 610 is positioned anywhere between inlet 604 and outlet 606. As described above, atomizer 610 is configured to heat and vaporize the payload contained in a payload reservoir (not shown) so as to output a vaporized payload. During a user inhalation, ambient air flows through conduit 612 from inlet 604 to atomizer 610, and ambient air mixed with vaporized payload flows through conduit 612 from atomizer 610 to outlet 606. Outlet 606 may further be in communication with a mouthpiece, as described above. Of course, it should be understood that vape device 600 may include a number of other components that are not specifically shown in FIG. 6, including a power source, a microcontroller, and other electronics, as described above in connection with vape devices 10 and 100.

With respect to vape device 600, the microcontroller is programmed to control the power source (e.g., a battery) so that the power source transmits a power signal (e.g., a direct current or pulsed direct current) to atomizer 610 in accordance with desired operational settings. When the heating element of atomizer 610 reaches the vaporization temperature of the payload contained in the payload reservoir, a portion of the payload is vaporized to thereby generate the vaporized payload for user inhalation. As described above, the microcontroller is programmed to determine the dose of vaporized payload based on a plurality of light intensity measurements obtained during user inhalation (and optionally before and after user inhalation), wherein the light intensity measurements are associated with light reflected from the vaporized payload when the vaporized payload passes through conduit 612 from atomizer 610 to outlet 606.

As shown in FIG. 6, vape device 600 includes a light source 614 and a light detector 616 positioned side-by-side within housing 602 outside of conduit 612 between atomizer 610 and outlet 606. In this example, conduit 612 includes a transparent section 618 formed on its sidewall that is located adjacent to light source 614 and light detector 616. Transparent section 618 may be made of glass or any other transparent material known to those

- 37 -

skilled in the art. As used herein, the term "transparent" generally means transparency for light and includes both clear transparency as well as translucency. Generally, a material is considered transparent if at least about 50%, preferably about 60%, more preferably about 70%, more preferably about 80% and still more preferably about 90% of the light illuminating the material can pass through the material.

The light path between light source 614 and light detector 616 is indicated by dashed lines in FIG. 6. As can be seen, light source 614 is configured to emit light that passes through transparent section 618 and into conduit 612, whereby some of the light reflects off the vaporized payload within conduit 612 and passes back through transparent section 618 to light detector 616 (noting that some of the emitted light will not be reflected back to light detector 616). Light detector 616 is then configured to generate a signal representing the intensity of the reflected light. As discussed above, light source 614 and light detector 616 are incorporated into a light intensity measurement circuit configured to obtain a plurality of light intensity measurements during each user inhalation (and optionally before and after user inhalation) and provide such measurements to the microcontroller of vape device 600.

It should be understood that various modifications could be made to vape device 600 within the scope of the present invention. For example, in some embodiments, light source 614 and light detector 616 are positioned within conduit 612 (e.g., attached on a sidewall of conduit 612) so that the vaporized payload can flow past light source 614 and light detector 616, provided that appropriate steps are taken to protect the integrity of the components within conduit 612. In this case, transparent section 618 of conduit 612 would not be required. Of course, other modifications will be apparent to those skilled in the art.

Referring to FIG. 7, a second example of a vape device that relies on a light intensity measurement method to determine the dose of vaporized payload is shown generally as reference numeral 700. Vape device 700 includes a housing 702, which may comprise an internal housing or external housing of vape device 700. Positioned within housing 702 is an air flow chamber which, in this example, comprises a conduit 712 that extends between an inlet 704 and an outlet 706. It can be appreciated that the inlet and outlet orifices are defined by conduit 712. An atomizer 710 is positioned anywhere between inlet 704 and outlet 706. As described above, atomizer 710 is configured to heat and vaporize the payload contained in a payload reservoir (not shown) so as to output a vaporized payload. During a user inhalation, ambient air flows through conduit 712 from inlet 704 to atomizer 710, and ambient air mixed with vaporized payload flows through conduit 712 from atomizer 710 to outlet 706. Outlet 706

- 38 -

may further be in communication with a mouthpiece, as described above. Of course, it should be understood that vape device 700 may include a number of other components that are not specifically shown in FIG. 7, including a power source, a microcontroller, and other electronics, as described above in connection with vape devices 10 and 100.

5 With respect to vape device 700, the microcontroller is programmed to control the power source (e.g., a battery) so that the power source transmits a power signal (e.g., a direct current or pulsed direct current) to atomizer 710 in accordance with desired operational settings. When the heating element of atomizer 710 reaches the vaporization temperature of the payload contained in the payload reservoir, a portion of the payload is vaporized to thereby
10 generate the vaporized payload for user inhalation. As described above, the microcontroller is programmed to determine the dose of vaporized payload based on a plurality of light intensity measurements obtained during user inhalation (and optionally before and after user inhalation), wherein the light intensity measurements are associated with light transmitted through the vaporized payload when the vaporized payload passes through conduit 712 from atomizer 710
15 to outlet 706.

 As shown in FIG. 7, vape device 700 includes a light source 714 and a light detector 716 positioned within housing 702 outside of conduit 712 between atomizer 710 and outlet 706, wherein light source 714 is positioned on a first side of conduit 712 and light detector 716 is positioned on a second opposing side of conduit 712. In this example, conduit
20 712 includes a first transparent section 718 formed on its sidewall adjacent light source 714 and a second transparent section 720 formed on its sidewall adjacent light detector 716. Transparent sections 718 and 720 may be made of glass or any other transparent material known to those skilled in the art.

 The light path between light source 714 and light detector 716 is indicated by
25 dashed lines in FIG. 7. As can be seen, light source 714 is configured to emit light that passes through transparent section 718 and into conduit 712, whereby the light travels through the vaporized payload within conduit 712 (noting that some of the light is absorbed by the vaporized payload) and passes through transparent section 720 to light detector 716. Light detector 716 is then configured to generate a signal representing the intensity of the light that
30 is received at light detector 716. As discussed above, light source 714 and light detector 716 are incorporated into a light intensity measurement circuit configured to obtain a plurality of light intensity measurements during each user inhalation (and optionally before and after user inhalation) and provide such measurements to the microcontroller of vape device 700.

- 39 -

It should be understood that various modifications could be made to vape device 700 within the scope of the present invention. For example, in some embodiments, light source 714 and light detector 716 are positioned within conduit 712 (e.g., attached on opposing sidewalls of conduit 712) so that the vaporized payload can flow past light source 714 and light detector 716, provided that appropriate steps are taken to protect the integrity of the components within conduit 712. In this case, transparent sections 718 and 720 of conduit 712 would not be required. Of course, other modifications will be apparent to those skilled in the art.

Referring to FIG. 8, a third example of a vape device that relies on a light intensity measurement method to determine the dose of vaporized payload is shown generally as reference numeral 800. In this example, vape device 800 includes a cartridge 808 and a control assembly 814 formed in separate housings 802 and 832, respectively, which are releasably connected to each other via an electromechanical connection, as described above. Housings 802 and 832 may comprise an internal housing or external housing of cartridge 808 and control assembly 814, respectively. Positioned within housings 802 and 832 is an air flow chamber which, in this example, comprises a conduit 812 that extends between an inlet 804 within control assembly 814 and an outlet 806 within cartridge 808. It can be appreciated that the inlet and outlet orifices are defined by conduit 812. An atomizer 810 is positioned anywhere between inlet 804 and outlet 806 within cartridge 808. As described above, atomizer 810 is configured to heat and vaporize the payload contained in a payload reservoir (not shown) so as to output a vaporized payload. During a user inhalation, ambient air flows through conduit 812 from inlet 804 to atomizer 810, and ambient air mixed with vaporized payload flows through conduit 812 from atomizer 810 to outlet 806. Outlet 806 may further be in communication with a mouthpiece, as described above. Of course, it should be understood that vape device 800 may include a number of other components that are not specifically shown in FIG. 8, including a power source, a microcontroller, and other electronics positioned in control assembly 814, as described above in connection with vape devices 10 and 100. It should also be understood that conduit 812 may be positioned entirely within cartridge 808, in which case conduit 812 would not extend through control assembly 814 as shown.

With respect to vape device 800, the microcontroller is programmed to control the power source (e.g., a battery) so that the power source transmits a power signal (e.g., a direct current or pulsed direct current) over the electromechanical connection to atomizer 810 in accordance with desired operational settings. When the heating element of atomizer 810

- 40 -

reaches the vaporization temperature of the payload contained in the payload reservoir, a portion of the payload is vaporized to thereby generate the vaporized payload for user inhalation. As described above, the microcontroller is programmed to determine the dose of vaporized payload based on a plurality of light intensity measurements obtained during user inhalation (and optionally before and after user inhalation), wherein the light intensity measurements are associated with light transmitted through the vaporized payload when the vaporized payload passes through conduit 812 from atomizer 810 to outlet 806.

As shown in FIG. 8, vape device 800 includes a light source 816 and a light detector 818 positioned within housing 832 of control assembly 814 outside of conduit 812, wherein light source 816 is positioned on a first side of conduit 812 and light detector 818 is positioned on a second opposing side of conduit 812. Also, the interface between control assembly 814 and cartridge 808 includes a first transparent window 820 located adjacent light source 816 and a second transparent window 822 located adjacent light detector 818. In addition, a first reflective surface 824 and a second reflective surface 826 are located within housing 802 of cartridge 808. As can be seen, first reflective surface 824 and first transparent window 820 are positioned to align with light source 816, and second reflective surface 826 and second transparent window 822 are positioned to align with light detector 818. Further, conduit 812 includes a first transparent section 828 formed on its sidewall adjacent first reflective surface 824 and a second transparent section 830 formed on its sidewall adjacent second reflective surface 826. Transparent sections 828 and 830 may be made of glass or any other transparent material known to those skilled in the art.

The light path between light source 816 and light detector 818 is indicated by dashed lines in FIG. 8. As can be seen, light source 816 is configured to emit light that passes through first transparent window 820 to first reflective surface 824, whereby the light is reflected and redirected through first transparent section 828 and into conduit 812. The light then travels through the vaporized payload within conduit 812 (noting that some of the light is absorbed by the vaporized payload) and passes through second transparent section 830 to second reflective surface 826, whereby the light is reflected and redirected through second transparent window 822 to light detector 818. Light detector 818 is then configured to generate a signal representing the intensity of the light that is received at light detector 818. As discussed above, light source 816 and light detector 818 are incorporated into a light intensity measurement circuit configured to obtain a plurality of light intensity measurements during

- 41 -

each user inhalation (and optionally before and after user inhalation) and provide such measurements to the microcontroller of vape device 800.

Referring to FIG. 9, a fourth example of a vape device that relies on a light intensity measurement method to determine the dose of vaporized payload is shown generally as reference numeral 900. In this example, vape device 900 includes a cartridge 908 and a control assembly 914 formed in separate housings 902 and 928, respectively, which are releasably connected to each other via an electromechanical connection, as described above. Housings 902 and 928 may comprise an internal housing or external housing of cartridge 908 and control assembly 914, respectively. Positioned within housings 902 and 928 is an air flow chamber which, in this example, comprises a conduit 912 that extends between an inlet 904 within control assembly 914 and an outlet 906 within cartridge 908. It can be appreciated that the inlet and outlet orifices are defined by conduit 912. An atomizer 910 is positioned between inlet 904 and outlet 906 within cartridge 908. As described above, atomizer 910 is configured to heat and vaporize the payload contained in a payload reservoir (not shown) so as to output a vaporized payload. During a user inhalation, ambient air flows through conduit 912 from inlet 904 to atomizer 910, and ambient air mixed with vaporized payload flows through conduit 912 from atomizer 910 to outlet 906. Outlet 906 may further be in communication with a mouthpiece, as described above. Of course, it should be understood that vape device 900 may include a number of other components that are not specifically shown in FIG. 9, including a power source, a microcontroller, and other electronics positioned in control assembly 914, as described above in connection with vape devices 10 and 100. It should also be understood that conduit 912 may be positioned entirely within cartridge 908, in which case conduit 912 would not extend through control assembly 914 as shown.

With respect to vape device 900, the microcontroller is programmed to control the power source (e.g., a battery) so that the power source transmits a power signal (e.g., a direct current or pulsed direct current) to atomizer 910 in accordance with desired operational settings. When the heating element of atomizer 910 reaches the vaporization temperature of the payload contained in the payload reservoir, a portion of the payload is vaporized to thereby generate the vaporized payload for user inhalation. As described above, the microcontroller is programmed to determine the dose of vaporized payload based on a plurality of light intensity measurements obtained during user inhalation (and optionally before and after user inhalation), wherein the light intensity measurements are associated with light transmitted through the

- 42 -

vaporized payload when the vaporized payload passes through conduit 912 from atomizer 910 to outlet 906.

As shown in FIG. 9, vape device 900 includes a light source 916 and a light detector 918 positioned in close proximity to each other within housing 928 of control assembly 914 outside of conduit 912. Also, the interface between control assembly 914 and cartridge 908 includes a transparent window 920 located adjacent light source 916 and light detector 918. In addition, a reflective surface 922 is located within housing 902 of cartridge 908. As can be seen, reflective surface 922 and transparent window 920 are positioned to align with light source 916 and light detector 918. Further, conduit 912 includes a transparent section 924 formed on its sidewall adjacent reflective surface 922 and a reflective section 926 formed on an opposing sidewall. Transparent section 924 may be made of glass or any other transparent material known to those skilled in the art. Reflective section 926 may be made of polished stainless steel or any other reflective material known to those skilled in the art. If the section of conduit 912 opposite transparent section 924 is sufficiently reflective (e.g., if conduit 912 is made of stainless steel), then a separate reflective section 926 would not be required and that section of conduit 912 would serve as the reflective section.

The light path between light source 916 and light detector 918 is indicated by dashed lines in FIG. 9. As can be seen, light source 916 is configured to emit light that passes through transparent window 920 to reflective surface 922, whereby the light is reflected and redirected through transparent section 924 and into conduit 912. The light then travels through the vaporized payload to reflective section 926, whereby the light is reflected and redirected back through the vaporized payload (noting that some of the light is absorbed by the vaporized payload). The light then passes through transparent section 924 to reflective surface 922, whereby the light is reflected and redirected through transparent window 904 to light detector 918. Light detector 918 is then configured to generate a signal representing the intensity of the light that is received at light detector 918. As discussed above, light source 916 and light detector 918 are incorporated into a light intensity measurement circuit configured to obtain a plurality of light intensity measurements during each user inhalation (and optionally before and after user inhalation) and provide such measurements to the microcontroller of vape device 900.

Referring to FIG. 10, a fifth example of a vape device that relies on a light intensity measurement method to determine the dose of vaporized payload is shown generally as reference numeral 1000. In this example, vape device 1000 includes a cartridge 1008 and a

- 43 -

control assembly 1014 formed in separate housings 1002 and 1028, respectively, which are releasably connected to each other via an electromechanical connection, as described above. Housings 1002 and 1028 may comprise an internal housing or external housing of cartridge 1008 and control assembly 1014, respectively. Positioned within housings 1002 and 1028 is an air flow chamber which, in this example, comprises a conduit 1012 that extends between an inlet 1004 within control assembly 1014 and an outlet 1006 within cartridge 1008. It can be appreciated that the inlet and outlet orifices are defined by conduit 1012. An atomizer 1010 is positioned anywhere between inlet 1004 and outlet 1006 within cartridge 1008. As described above, atomizer 1010 is configured to heat and vaporize the payload contained in a payload reservoir (not shown) so as to output a vaporized payload. During a user inhalation, ambient air flows through conduit 1012 from inlet 1004 to atomizer 1010, and ambient air mixed with vaporized payload flows through conduit 1012 from atomizer 1010 to outlet 1006. Outlet 1006 may further be in communication with a mouthpiece, as described above. Of course, it should be understood that vape device 1000 may include a number of other components that are not specifically shown in FIG. 10, including a power source, a microcontroller, and other electronics positioned in control assembly 1014, as described above in connection with vape devices 10 and 100. It should also be understood that conduit 1012 may be positioned entirely within cartridge 1008, in which case conduit 1012 would not extend through control assembly 1014 as shown.

With respect to vape device 1000, the microcontroller is programmed to control the power source (e.g., a battery) so that the power source transmits a power signal (e.g., a direct current or pulsed direct current) to atomizer 1010 in accordance with desired operational settings. When the heating element of atomizer 1010 reaches the vaporization temperature of the payload contained in the payload reservoir, a portion of the payload is vaporized to thereby generate the vaporized payload for user inhalation. As described above, the microcontroller is programmed to determine the dose of vaporized payload based on a plurality of light intensity measurements obtained during user inhalation (and optionally before and after user inhalation), wherein the light intensity measurements are associated with light transmitted through the vaporized payload when the vaporized payload passes through conduit 1012 from atomizer 1010 to outlet 1006.

As shown in FIG. 10, vape device 1000 includes a light source 1016 positioned within housing 1002 of cartridge 1008 outside of conduit 1012 and a light detector 1018 positioned within housing 1028 of control assembly 1014 outside of conduit 1012. Also, the

- 44 -

interface between control assembly 1014 and cartridge 1008 includes a transparent window 1020 located adjacent light detector 1018. In addition, a reflective surface 1022 is located within housing 1002 of cartridge 1008 outside of conduit 1012. As can be seen, reflective surface 1022 and transparent window 1020 are positioned to align with light detector 1018.

5 Further, conduit 1012 includes a first transparent section 1024 formed on its sidewall adjacent reflective surface 1022 and a second transparent section 1026 formed on an opposing sidewall. Transparent sections 1024 and 1026 may be made of glass or any other transparent material known to those skilled in the art.

The light path between light source 1016 and light detector 1018 is indicated by dashed lines in FIG. 10. As can be seen, light source 1016 is configured to emit light that

10 passes through second transparent section 1026 and into conduit 1012. The light travels through the vaporized payload within conduit 1012 (noting that some of the light is absorbed by the vaporized payload) and passes through first transparent section 1024 to reflective surface 1022, whereby the light is reflected and redirected through transparent window 1020 to light

15 detector 1018. Light detector 1018 is then configured to generate a signal representing the intensity of the light that is received at light detector 1018. As discussed above, light source 1016 and light detector 1018 are incorporated into a light intensity measurement circuit configured to obtain a plurality of light intensity measurements during each user inhalation (and optionally before and after user inhalation) and provide such measurements to the

20 microcontroller of vape device 1000.

Referring to FIG. 11A, a sixth example of a vape device that relies on a light intensity measurement method to determine the dose of vaporized payload is shown generally as reference numeral 1100. Vape device 1100 includes a housing 1102, which may comprise an internal housing or external housing of vape device 1100. Positioned within housing 1102

25 is an air flow chamber which, in this example, comprises a conduit 1112 that extends between an inlet 1104 and an outlet 1106. It can be appreciated that the inlet and outlet orifices are defined by conduit 1112. An atomizer 1110 is positioned anywhere between inlet 1104 and outlet 1106. As described above, atomizer 1110 is configured to heat and vaporize the payload contained in a payload reservoir (not shown) so as to output a vaporized payload. During a

30 user inhalation, ambient air flows through conduit 1112 from inlet 1104 to atomizer 1110, and ambient air mixed with vaporized payload flows through conduit 1112 from atomizer 1110 to outlet 1106. Outlet 1106 may further be in communication with a mouthpiece, as described above. Of course, it should be understood that vape device 1100 may include a number of

- 45 -

other components that are not specifically shown in FIG. 11A, including a power source, a microcontroller, and other electronics, as described above in connection with vape devices 10 and 100.

With respect to vape device 1100, the microcontroller is programmed to control the power source (e.g., a battery) so that the power source transmits a power signal (e.g., a direct current or pulsed direct current) to atomizer 1110 in accordance with desired operational settings. When the heating element of atomizer 1110 reaches the vaporization temperature of the payload contained in the payload reservoir, a portion of the payload is vaporized to thereby generate the vaporized payload for user inhalation. As described above, the microcontroller is programmed to determine the dose of vaporized payload based on a plurality of light intensity measurements obtained before, during, and after user inhalation, wherein the light intensity measurements in this example are associated with light transmitted through a light transmitting medium positioned parallel to the path of the vaporized payload within conduit 1112, as described below.

As shown in FIG. 11A, vape device 1100 includes a light source 1114 and a light detector 1116 spaced apart from each other within housing 1102 outside of conduit 1112 between atomizer 1110 and outlet 1106. Also, vape device 1100 includes one or more fibers made of glass, plastic, or another material with an index of refraction that is sufficiently similar to that of the payload and sufficiently different from that of air, as discussed above, which will be referred to herein as a "glass fiber 1118" for ease of reference. In this example, glass fiber 1118 is positioned substantially inside of conduit 1112 and extends generally parallel to the direction of the airflow. One end 1118a of glass fiber 1118 extends through an opening in the sidewall of conduit 1112 so as to be positioned outside of conduit 1112 adjacent light source 1114. The other end 1118b of glass fiber 1118 penetrates through another opening in the sidewall of conduit 1112 so as to be positioned outside of conduit 1112 adjacent light detector 1116. Any suitable sealant may be used to seal the openings in conduit 1112 so as to prevent the leakage of vaporized payload therethrough.

The light path between light source 1114 and light detector 1116 through glass fiber 1118 can be understood with reference to the simplified diagrams shown in FIGS. 11B and 11C.

FIG. 11B shows the surface of glass fiber 1118 surrounded entirely by air, i.e., prior to any use of vape device 1100. The light emitted by light source 1114 travels through glass fiber 1118 to light detector 1116 in a light path indicated by the dashed lines in FIG. 11B.

- 46 -

As can be seen, when the light impacts each glass/air boundary at an angle, the light totally reflects back into glass fiber 1118 (i.e., total internal reflection) due to the differences between their respective indexes of refraction. Thus, the light detected by light detector 1116 has substantially the same intensity as the light emitted by light source 1114.

5 FIG. 11C shows the surface of glass fiber 1118 with vaporized payload (an oil droplet in this example) deposited on a portion of the surface. The light emitted by light source 1114 travels through glass fiber 1118 to light detector 1116 in a light path indicated by the dashed lines in FIG. 11C. As can be seen, when the light impacts the glass/oil boundary at an angle, the light will escape glass fiber 1118 and enter the oil, and some of the light may further
10 escape the oil into the air. However, when the light impacts the glass/air boundary at an angle (i.e., in areas where there are no oil droplets on the surface), the light reflects back into glass fiber 1118. Thus, the level of attenuation of the light received by light detector 1116 will be dependent on the amount of oil deposited on the surface of glass fiber 1118.

 It can be appreciated that light detector 1116 is configured to generate a signal
15 representing the intensity of the received light. As discussed above, light source 1114 and light detector 1116 are incorporated into a light intensity measurement circuit configured to obtain a plurality of light intensity measurements before, during, and after each user inhalation and provide such measurements to the microcontroller of vape device 1100.

 It should be understood that various modifications could be made to vape device
20 1100 within the scope of the present invention. For example, in some embodiments, glass fiber 1118 is positioned entirely inside of conduit 1112. In this case, a first transparent section is formed on the sidewall of conduit 1112 adjacent light source 1114 to provide a light path between glass fiber 1118 and light source 1114 and, similarly, a second transparent section is formed on the sidewall of conduit 1112 adjacent light detector 1116 to provide a light path
25 between glass fiber 1118 and light detector 1116. The transparent sections may be made of glass or any other transparent material known to those skilled in the art. In this case, conduit 1112 would not need openings for the ends of glass fiber 1118. In yet other embodiments, glass fiber 1118 is replaced with another material having an index of refraction similar to that of the vaporized payload, as discussed above. Of course, other modifications will be apparent
30 to those skilled in the art.

 Referring to FIG. 12, a seventh example of a vape device that relies on a light intensity measurement method to determine the dose of vaporized payload is shown generally as reference numeral 1200. Vape device 1200 includes a housing 1202, which may comprise

- 47 -

an internal housing or external housing of vape device 1200. Positioned within housing 1202 is an air flow chamber which, in this example, comprises a conduit 1212 that extends between an inlet 1204 and an outlet 1206. It can be appreciated that the inlet and outlet orifices are defined by conduit 1212. An atomizer 1210 is positioned anywhere between inlet 1204 and outlet 1206. As described above, atomizer 1210 is configured to heat and vaporize the payload contained in a payload reservoir (not shown) so as to output a vaporized payload. During a user inhalation, ambient air flows through conduit 1212 from inlet 1204 to atomizer 1210, and ambient air mixed with vaporized payload flows through conduit 1212 from atomizer 1210 to outlet 1206. Outlet 1206 may further be in communication with a mouthpiece, as described above. Of course, it should be understood that vape device 1200 may include a number of other components that are not specifically shown in FIG. 12, including a power source, a microcontroller, and other electronics, as described above in connection with vape devices 10 and 100.

With respect to vape device 1200, the microcontroller is programmed to control the power source (e.g., a battery) so that the power source transmits a power signal (e.g., a direct current or pulsed direct current) to atomizer 1210 in accordance with desired operational settings. When the heating element of atomizer 1210 reaches the vaporization temperature of the payload contained in the payload reservoir, a portion of the payload is vaporized to thereby generate the vaporized payload for user inhalation. As described above, the microcontroller is programmed to determine the dose of vaporized payload based on a plurality of light intensity measurements obtained before, during, and after user inhalation, wherein the light intensity measurements in this example are associated with light transmitted through a light transmitting medium positioned perpendicular to the path of the vaporized payload within conduit 1212, as described below.

As shown in FIG. 12, vape device 1200 includes a light source 1214 and a light detector 1216 positioned within housing 1202 outside of conduit 1212 between atomizer 1210 and outlet 1206, wherein light source 1214 is positioned on a first side of conduit 1212 and light detector 1216 is positioned on a second opposing side of conduit 1212. Also, vape device 1200 includes one or more fibers made of glass, plastic, or another material with an index of refraction that is sufficiently similar to that of the payload and sufficiently different from that of air, as discussed above, which will be referred to herein as a "glass fiber 1218" for ease of reference. Glass fiber 1218 is positioned substantially inside of conduit 1212 and extends generally perpendicular to the direction of the airflow. One end 1218a of glass fiber 1218

- 48 -

extends through an opening in the sidewall of conduit 1212 so as to be positioned outside of conduit 1212 adjacent light source 1214. The other end 1218b of glass fiber 1218 penetrates through another opening in the sidewall of conduit 1212 so as to be positioned outside of conduit 1212 adjacent light detector 1216. Any suitable sealant may be used to seal the openings in conduit 1212 so as to prevent the leakage of vaporized payload therethrough.

The light path between light source 1214 and light detector 1216 through glass fiber 1218 can be understood from the description of FIGS. 11B and 11C above, wherein light detector 1216 is configured to generate a signal representing the intensity of the received light. As discussed above, light source 1214 and light detector 1216 are incorporated into a light intensity measurement circuit configured to obtain a plurality of light intensity measurements before, during, and after each user inhalation and provide such measurements to the microcontroller of vape device 1200.

It should be understood that various modifications could be made to vape device 1200 within the scope of the present invention. For example, in some embodiments, glass fiber 1218 is positioned entirely inside of conduit 1212. In this case, a first transparent section is formed on the sidewall of conduit 1212 adjacent light source 1214 to provide a light path between glass fiber 1218 and light source 1214 and, similarly, a second transparent section is formed on the sidewall of conduit 1212 adjacent light detector 1216 to provide a light path between glass fiber 1218 and light detector 1216. The transparent sections may be made of glass or any other transparent material known to those skilled in the art. In this case, conduit 1212 would not need openings for the ends of glass fiber 1218. In yet other embodiments, glass fiber 1218 is replaced with another material having an index of refraction similar to that of the vaporized payload, as discussed above. Of course, other modifications will be apparent to those skilled in the art.

Referring to FIG. 13, an eighth example of a vape device that relies on a light intensity measurement method to determine the dose of vaporized payload is shown generally as reference numeral 1300. Vape device 1300 includes a housing 1302, which may comprise an internal housing or external housing of vape device 1300. Positioned within housing 1302 is an air flow chamber which, in this example, comprises a conduit 1312 that extends between an inlet 1304 and an outlet 1306. It can be appreciated that the inlet and outlet orifices are defined by conduit 1312. An atomizer 1310 is positioned anywhere between inlet 1304 and outlet 1306. As described above, atomizer 1310 is configured to heat and vaporize the payload contained in a payload reservoir (not shown) so as to output a vaporized payload. During a

- 49 -

user inhalation, ambient air flows through conduit 1312 from inlet 1304 to atomizer 1310, and ambient air mixed with vaporized payload flows through conduit 1312 from atomizer 1310 to outlet 1306. Outlet 1306 may further be in communication with a mouthpiece, as described above. Of course, it should be understood that vape device 1300 may include a number of other components that are not specifically shown in FIG. 13, including a power source, a microcontroller, and other electronics, as described above in connection with vape devices 10 and 100.

With respect to vape device 1300, the microcontroller is programmed to control the power source (e.g., a battery) so that the power source transmits a power signal (e.g., a direct current or pulsed direct current) to atomizer 1310 in accordance with desired operational settings. When the heating element of atomizer 1310 reaches the vaporization temperature of the payload contained in the payload reservoir, a portion of the payload is vaporized to thereby generate the vaporized payload for user inhalation. As described above, the microcontroller is programmed to determine the dose of vaporized payload based on a plurality of light intensity measurements obtained before, during and after user inhalation, wherein the light intensity measurements in this example are associated with light transmitted through a glass section of conduit 1312, as described below.

As shown in FIG. 13, vape device 1300 includes a light source 1314 and a light detector 1316 spaced apart from each other within housing 1302 outside of conduit 1312 between atomizer 1310 and outlet 1306. Also, in this example, conduit 1312 includes a flat or curved section made of glass, plastic, or another material with an index of refraction that is sufficiently similar to that of the payload and sufficiently different from that of air, as discussed above, which will be referred to herein as a "glass section 1318" for ease of reference. Glass section 1318 extends along the length of conduit 1312 such that one end of glass section 1318 is positioned adjacent light source 1314 and the other end of glass section 1318 is positioned adjacent light detector 1316.

The light path between light source 1314 and light detector 1316 through glass section 1318 can be understood from the description of FIGS. 11B and 11C above, wherein light detector 1316 is configured to generate a signal representing the intensity of the received light. As discussed above, light source 1314 and light detector 1316 are incorporated into a light intensity measurement circuit configured to obtain a plurality of light intensity measurements before, during and after each user inhalation and provide such measurements to the microcontroller of vape device 1300.

- 50 -

It should be understood that various modifications could be made to vape device 1300 within the scope of the present invention. For example, in some embodiments, a mirrored coating may be applied to the non-vapor side of glass section 1318, i.e., the outside surface of glass section 1318. In this case, light would still escape glass section 1318 when vaporized
5 payload is deposited on the inside surface of glass section 1318. In other embodiments, all of conduit 1312 (not just glass section 1318) may be made of glass – either with or without a mirrored coating on the outside surface of conduit 1312. In yet other embodiments, glass section 1318 is made of another material having an index of refraction similar to that of the vaporized payload, as discussed above. Of course, other modifications will be apparent to
10 those skilled in the art.

It should also be understood that any of vape devices 1100, 1200 and 1300 could be modified by placing a mirrored finish on the far end of the light transmitting medium from the light source so that the light sensor may be co-located with the light source. If the vape device includes a cartridge and a control assembly formed in separate housings that are
15 releasably connected to each other via an electromechanical connection, as described above, this modification would enable the light source and/or the light detector to be positioned within the control assembly while the light transmitting medium is located within the cartridge (similar to the configurations shown in FIGS. 8-10).

Of course, other modifications to vape devices 1100, 1200 and 1300 will be
20 apparent to those skilled in the art. For example, the glass fiber may be oriented at any angle within the conduit and is not limited to being positioned parallel to the direction of airflow (as in the vape device of FIG. 11A) or perpendicular to the direction of airflow (as in the vape device of FIG. 12). In addition, the glass fiber may follow the contour of the conduit, either in a direct line or helix.

25 Further, in each of the vape devices shown in FIGS. 6-13 above, the light intensity measurement circuit is configured to provide the light intensity measurements obtained during user inhalation (and optionally before and after user inhalation) to the microcontroller of the vape device. In some embodiments, the microcontroller is programmed to determine the dose of payload that is vaporized during each user inhalation by performing
30 the following steps: (1) acquiring a plurality of light intensity measurements from the light intensity measurement circuit during user inhalation (and optionally before and after user inhalation) and (2) using the information from step 1 to determine the vapor density of the

- 51 -

vaporized payload and by extension the partial mass of the payload that is vaporized during user inhalation.

In some embodiments, the method may be further refined (optionally) by varying the intensity of the light signal emitted by the light source and/or the gain of the light detector in order to adjust the sensitivity.

In some embodiments, the method may be further refined (optionally) by applying an electric field to the air flow chamber so as to orient a plurality of molecules in the vaporized payload when the vaporized payload passes through the conduit in order to improve their reflective properties.

Finally, it should be understood that all or a portion of the processing steps performed by the microcontroller of the vape device, as described above, could alternatively be performed by one or more other microcontrollers, such as a secondary microcontroller positioned in a cartridge of the vape device (for embodiments in which the vape device comprises a cartridge releasably connected to a control assembly). Various embodiments will be apparent to those skilled in the art.

***Dose Determination/Vapor Droplet Counting Method
Using Hot Wire Anemometers***

In some embodiments, the vape device utilizes two or more hot wire anemometers to determine the mass of the vaporized payload that was delivered to the user during each user inhalation and/or to determine the size and density distribution of the droplets in the vaporized payload and use such distribution to calculate the total mass of the vaporized payload that was delivered to the user during each user inhalation.

Referring to FIG. 14, an example of a vape device that relies on this method to determine the dose of vaporized payload is shown generally as reference numeral 1400. Vape device 1400 includes a housing 1402, which may comprise an internal housing or external housing of vape device 1400. Positioned within housing 1402 is an air flow chamber which, in this example, comprises a conduit 1412 that extends between an inlet 1404 and an outlet 1406. It can be appreciated that the inlet and outlet orifices are defined by conduit 1412. An atomizer 1410 is positioned anywhere between inlet 1404 and outlet 1406. As described above, atomizer 1410 is configured to heat and vaporize the payload contained in a payload reservoir (not shown) so as to output a vaporized payload. During a user inhalation, ambient air flows through conduit 1412 from inlet 1404 to atomizer 1410, and ambient air mixed with vaporized payload flows through conduit 1412 from atomizer 1410 to outlet 1406. Outlet 1406 may

- 52 -

further be in communication with a mouthpiece, as described above. Of course, it should be understood that vape device 1400 may include a number of other components that are not specifically shown in FIG. 14, including a power source, a microcontroller, and other electronics, as described above in connection with vape devices 10 and 100.

5 With respect to vape device 1400, the microcontroller is programmed to control the power source (e.g., a battery) so that the power source transmits a power signal (e.g., a direct current or pulsed direct current) to atomizer 1410 in accordance with desired operational settings. When the heating element of atomizer 1410 reaches the vaporization temperature of the payload contained in the payload reservoir, a portion of the payload is vaporized to thereby
10 generate the vaporized payload for user inhalation.

 A rough dose estimate for each user inhalation can be determined by integrating the power draw versus time of the heating element of atomizer 1410 and comparing it with the amount of payload theoretically vaporized based on the specific heat and heat of vaporization of the payload. However, this dose estimate may not be accurate enough for critical
15 pharmaceutical delivery applications, especially in the case of multi-component payloads in which partial fractionation of the mixture may occur at the interface between the wick and heating element of atomizer 1410. Therefore, in order to provide a more accurate and repeatable measurement of the total mass of the payload vaporized during each user inhalation, vape device 1400 may utilize a number of different components and circuits, as described
20 below.

 In this example, vape device 1400 includes three hot wire anemometers—a reference hot wire anemometer 1414 located within conduit 1412 between inlet 1404 and atomizer 1410 and two sampling hot wire anemometers 1416 and 1418 located within conduit 1412 between atomizer 1410 and outlet 1406. The wire filament of each of these anemometers
25 may be made of tungsten, platinum or platinum-iridium, although other materials known to those skilled in the art may also be used.

 Vape device 1400 also includes two temperature sensors—a first temperature sensor 1420 located within conduit 1412 between inlet 1404 and atomizer 1410 and a second temperature sensor 1422 located within conduit 1412 between atomizer 1410 and outlet 1406.
30 Each of temperature sensors 1420 and 1422 may comprise any type of component capable of sensing the temperature at the designated locations, such as a thermistor, a thermocouple, an infrared sensor, a bandgap temperature sensor, an analog temperature sensor, or a digital

- 53 -

temperature sensor. Of course, those skilled in the art will understand that other types of temperature sensors may be used in accordance with the present invention.

Reference hot wire anemometer 1414 is incorporated into a circuit configured to measure the velocity of air flowing over the wire. The circuit may comprise, for example, a constant temperature Wheatstone bridge circuit, as known to those skilled in the art. During each user inhalation, an electric current is sent through the wire, causing the wire to become hot. As air flows over the wire, it cools the wire and removes some of its heat energy. By integrating the instantaneous heat loss from the wire over time, the anemometer provides a baseline reading of the air flow rate through conduit 1412 during user inhalation, which may be used along with the information from sampling hot wire anemometers 1416 and 1418 (discussed below) to determine the dose of the vaporized payload.

Sampling hot wire anemometer 1416 is incorporated into a circuit configured to measure the mass of vaporized payload passing by the wire during each user inhalation. By passing current through the wire of hot wire anemometer 1416 so that it operates at a temperature that is above the boiling point of each of the components in the payload, individual collisions of the wire with the droplets in the vaporized payload can be measured. Goldschmidt, Victor W. "Measurement of Aerosol Concentrations with a Hot Wire Anemometer," *Journal of Colloid Science* 20, 617-634 (1965). Counting the number of droplets detected over time can serve as input in determining the total mass of vaporized payload delivered during each user inhalation, provided the size distribution of the droplets in the vaporized payload is known, narrow and constant. This enables the accuracy of the dose determination to be significantly improved. It should be understood that sampling hot wire anemometer 1418 operates in the same manner.

Sampling hot wire anemometers 1416 and 1418 may also be operated at different temperatures to enable detection of different components in the vaporized payload. For example, assume that the vaporized payload contains components A and B, wherein the boiling point of component A is lower than the boiling point of component B. In this case, hot wire anemometer 1416 is operated at a temperature that is higher than the boiling point of component A, but lower than the boiling point of component B. Also, hot wire anemometer 1418 is operated at a temperature that is higher than the boiling points of components A and B. It can be appreciated that this arrangement enables the dose of each of components A and B to be determined.

- 54 -

It should be noted that sampling hot wire anemometer 1416 may be fouled by deposition of component B. In order to address this issue, the "roles" of sampling hot wire anemometers 1416 and 1418 may be swapped between successive user inhalations (i.e., the operating temperatures of the anemometers are successively swapped) so that component B is vaporized over the course of using vape device 1400.

First temperature sensor 1420 is incorporated into a first temperature measurement circuit configured to obtain a plurality of temperature measurements during user inhalation in order to determine the ambient temperature of the incoming air. Second temperature sensor 1422 is incorporated into a second temperature measurement circuit configured to obtain a plurality of temperature measurements during user inhalation in order to determine the temperature of the vaporized payload/air mixture. This data may be used along with the information from reference hot wire anemometer 1414 and sampling hot wire anemometers 1416 and 1418 to determine the dose of the vaporized payload.

The above implementation is suitable for cases in which the size distribution of the droplets in the vaporized payload is known, narrow and constant. However, if the distribution of droplet sizes is wide and changing over the duration of the user inhalation, the accuracy of the dose determination will suffer. In order to address these issues, it is preferable to utilize a component and circuit arrangement that enables the microcontroller to determine the size and density distribution of the droplets in the vaporized payload and use such distribution to calculate the total mass of the vaporized payload that was delivered to the user during each user inhalation.

FIG. 15 shows an exemplary embodiment of such a component and circuit arrangement that may be incorporated into a vape device. In this example, the vape device includes a reference hot wire anemometer that operates in the same manner as reference hot wire anemometer 1414 described above. The vape device also includes an array of sampling hot wire anemometers (SHWAT₁, SHWAT₂, SHWAT₃ . . . SHWAT_{m-1}, SHWAT_m) each of which operates at a distinct temperature (T₁, T₂, T₃ . . . T_{m-1}, T_m) in order to enable detection of different components in the vaporized payload, as described above. In addition, the vape device includes two thermistors (Thermistor 1 and Thermistor 2) that operate in the same manner as temperature sensors 1420 and 1422 described above.

It can be seen that each of the sampling hot wire anemometers (SHWAT₁, SHWAT₂, SHWAT₃ . . . SHWAT_{m-1}, SHWAT_m) are connected to an array of monostable multivibrator (one shot) modules with different triggering thresholds (MM-TT₁, MM-TT₂,

- 55 -

MM-TT₃ . . . MM-TT_{n-1}, MM-TT_n) and an array of associated digital counters (DC-TT₁, DC -
TT₂, DC -TT₃ . . . DC -TT_{n-1}, DC -TT_n). The triggering thresholds of the monostable
multivibrator modules are segmented to cover bands of droplet size detection sensitivity in
order to more granularly determine the droplet size distribution and density in the vaporized
5 payload.

Specifically, each of the monostable multivibrator modules has an individual
triggering threshold tailored to be sensitive to a droplet of a minimum size. For example, the
most sensitive monostable multivibrator module would count every size droplet, and the second
most sensitive monostable multivibrator module would count every size droplet except the
10 smallest size droplet. By subtracting the number of droplets detected by the second most
sensitive monostable multivibrator module from the number of droplets detected by the most
sensitive monostable multivibrator module, the number of the smallest size droplets within that
band can be determined. This scheme can be extended until the desired number of droplet size
bands is represented. The size and density distribution of the droplets in the vaporized payload
15 may then be integrated over the time period of the user inhalation in order to calculate the total
mass of the vaporized payload that was delivered to the user during each user inhalation.

In some embodiments, a standardized aerosol generator may be used to calibrate
the vape device using various droplet size and density settings.

Finally, it should be understood that all or a portion of the processing steps
20 performed by the microcontroller of vape device 1400, as described above, could alternatively
be performed by one or more other microcontrollers, such as a secondary microcontroller (not
shown) positioned in a cartridge of vape device 1400 (for embodiments in which vape device
1400 comprises a cartridge releasably connected to a control assembly). Various embodiments
will be apparent to those skilled in the art.

25 ***Dose Control System***

The methods of measuring dosage described above may be used independently,
or in any combination, to record the dose administered to the user and report it to personal
computing device 72 or an equivalent device. Alternatively, the desired dose can be set in
advance by the user through an on-vaporizer input method (e.g., buttons, dial, etc.) or through
30 interaction with application 74 running on personal computing device 72. The user then inhales
until the user-specified dose is administered, at which point the vape device stops vaporizing
to thereby provide an accurate means of dose control.

III. General Information

In this disclosure, the use of any and all examples or exemplary language (e.g., "for example" or "as an example") is intended merely to better describe the invention and does not pose a limitation on the scope of the invention. No language in the disclosure should be construed as indicating any non-claimed element essential to the practice of the invention.

5

Also, the use of the terms "comprises," "comprising," or any other variation thereof, are intended to cover a non-exclusive inclusion, such that a system, device, or method that comprises a list of elements does not include only those elements, but may include other elements not expressly listed or inherent to such system, device, or method.

10

Further, the use of relative relational terms, such as first and second, are used solely to distinguish one unit or action from another unit or action without necessarily requiring or implying any actual such relationship or order between such units or actions.

Finally, while the present invention has been described and illustrated hereinabove with reference to various exemplary embodiments, it should be understood that various modifications could be made to these embodiments without departing from the scope of the invention. For example, while the methods of measuring dosage are described above for use in a vape device, some of these methods (e.g., the light measurement methods and/or hot wire anemometer methods) could be used in a nebulizer. Therefore, the present invention is not to be limited to the specific structural configurations, circuits or methodologies of the exemplary embodiments, except insofar as such limitations are included in the following claims.

15

20

CLAIMS

We claim:

1. A vape device for determining a dose of a payload delivered to a user during each of a plurality of user inhalations, comprising:

a payload reservoir configured to contain a payload to be vaporized;

an air flow chamber that extends between an inlet and an outlet;

a power source configured to generate a power signal during each respective user inhalation;

an atomizer located between the inlet and the outlet of the air flow chamber, wherein the atomizer is configured to receive the power signal and vaporize a portion of the payload to thereby generate a vaporized payload during each respective user inhalation; and

a microcontroller programmed to determine a dose of the vaporized payload for each respective user inhalation based on: (a) determining an amount of energy used to vaporize the portion of the payload during the user inhalation; and (b) determining a partial mass of the payload that is vaporized during the user inhalation based on the amount of energy used to vaporize the portion of the payload during the user inhalation.

2. The vape device of claim 1, wherein the payload comprises a fluid payload or a dry material payload containing at least one of nicotine, cannabis, cannabinoid, propylene glycol, polyethylene glycol, or vegetable glycerin.

3. The vape device of any of claims 1-2, wherein the microcontroller is further programmed to: (a) identify one or more components within the payload; (b) identify a relative percentage and a boiling point for each of the components within the payload; and (c) determine a mass of each of the components within the portion of the payload that is vaporized during the user inhalation.

4. The vape device of claim 3, wherein the microcontroller is further programmed to determine an optimal vaporization temperature for the payload based on the relative percentage and the boiling point for each of the components within the payload.

5. The vape device of any of claims 1-4, further comprising a memory device configured to store information that enables the microcontroller to correlate the amount of energy used to vaporize the portion of the payload during the user inhalation to the partial mass of the payload that is vaporized during the user inhalation.

- 58 -

6. The vape device of any of claims 1-5, wherein the vape device comprises a cartridge releasably connected to a control assembly, and wherein the microcontroller is contained within the control assembly.
7. The vape device of any of claims 1-5, wherein the vape device comprises a cartridge releasably connected to a control assembly, and wherein the microcontroller is contained within the cartridge.
8. The vape device of any of claims 1-7, wherein the power source comprises a battery, and wherein the power signal comprises a direct current or a pulsed direct current.
9. The vape device of any of claims 1-8, wherein the microcontroller is programmed to determine the amount of energy used to vaporize the portion of the payload during the user inhalation based on: (a) determining an amount of power provided to the atomizer during the user inhalation; (b) determining a duration of the user inhalation; and (c) determining a total amount of energy based on the amount of power provided to the atomizer during the user inhalation and the duration of the user inhalation.
10. The vape device of claim 9, wherein the microcontroller is programmed to determine the amount of power provided to the atomizer during the user inhalation based on: (a) a measurement of an output voltage of the power source during the user inhalation; and (b) a measurement of a current delivered to the atomizer during the user inhalation.
11. The vape device of claim 9, wherein the microcontroller is programmed to determine the amount of power provided to the atomizer during the user inhalation based on: (a) a measurement of a resistance of a path between the power source and the atomizer during the user inhalation; and (b) a measurement of an output voltage of the power source or a measurement of a current delivered to the atomizer during the user inhalation.
12. The vape device of any of claims 9-11, wherein the microcontroller is further programmed to determine the amount of energy used to vaporize the portion of the payload during the user inhalation based on: (a) determining an amount of energy used to heat the atomizer to a vaporization temperature during the user inhalation; and (b) adjusting the total amount of energy by subtracting the amount of energy used to heat the atomizer to the vaporization temperature during the user inhalation.

- 59 -

13. The vape device of any of any of claims 9-12, wherein the microcontroller is further programmed to determine the amount of energy used to vaporize the portion of the payload during the user inhalation by adjusting the total amount of energy to account for one or more of the following operating conditions: a starting temperature of the vape device, a starting temperature of the payload, a temperature of ambient air, a relative humidity of ambient air, a pressure of ambient air, an output voltage of the power source, and a temperature ramp rate of the atomizer.

14. The vape device of any of claims 9-13, wherein the microcontroller is programmed to determine the amount of energy used to vaporize the portion of the payload during the user inhalation based on: (a) determining an air flow rate within the air flow chamber during the user inhalation; and (b) adjusting the total amount of energy to account for the air flow rate.

15. The vape device of claim 14, wherein the air flow chamber defines an orifice having a cross-sectional area, and wherein the microcontroller is programmed to determine the air flow rate within the air flow chamber during the user inhalation based on: (a) a pressure difference across the orifice during the user inhalation; and (b) the cross-sectional area of the orifice.

16. The vape device of claim 15, further comprising:

a first pressure sensor located on a first side of the orifice, wherein the first pressure sensor is incorporated into a first pressure measurement circuit configured to obtain a first plurality of pressure measurements during the user inhalation;

a second pressure sensor located on a second opposing side of the orifice, wherein the second pressure sensor is incorporated into a second pressure measurement circuit configured to obtain a second plurality of pressure measurements during the user inhalation; and

wherein the pressure difference across the orifice during the user inhalation is based on the first and second plurality of pressure measurements.

17. The vape device of claim 15, further comprising:

a pressure sensor located on a side of the orifice, wherein the pressure sensor is incorporated into a pressure measurement circuit configured to obtain a plurality of pressure measurements before and during the user inhalation; and

wherein the pressure difference across the orifice during the user inhalation is based on the plurality of the pressure measurements.

18. The vape device of claim 15, further comprising:

- 60 -

a pressure sensor located on a side of the orifice, wherein the pressure sensor is incorporated into a pressure measurement circuit configured to obtain a plurality of pressure measurements during and after the user inhalation; and

wherein the pressure difference across the orifice during the user inhalation is based on the plurality of pressure measurements.

19. The vape device of claim 15, further comprising:

a pressure sensor located on a side of the orifice, wherein the pressure sensor is incorporated into a pressure measurement circuit configured to obtain a plurality of pressure measurements before, during, and after the user inhalation; and

wherein the pressure difference across the orifice during the user inhalation is based on the plurality of pressure measurements.

20. The vape device of any of claims 1-19, wherein the microcontroller is programmed to determine the dose of the vaporized payload for the user inhalation based further on: (a) a plurality of temperature measurements obtained with the air flow chamber during the user inhalation; and (b) the air flow rate within the air flow chamber during the user inhalation.

21. The vape device of claim 20, further comprising:

a first temperature sensor located within the air flow chamber between the inlet and the atomizer, wherein the first temperature sensor is incorporated into a first temperature measurement circuit configured to obtain a first plurality of temperature measurements during the user inhalation;

a second temperature sensor located within the air flow chamber between the atomizer and the outlet, wherein the second temperature sensor is incorporated into a second temperature measurement circuit configured to obtain a second plurality of temperature measurements during the user inhalation; and

wherein the plurality of temperature measurements comprise the first and second plurality of temperature measurements.

22. The vape device of claim 21, wherein each of the first and second temperature sensors comprises one of a thermistor, a thermocouple, an infrared sensor, a bandgap temperature sensor, an analog temperature sensor, or a digital temperature sensor.

23. The vape device of any of claims 20-22, wherein the microcontroller is programmed to determine the dose of the vaporized payload for the user inhalation based further on an air

moisture content and an atmospheric pressure within the air flow chamber between the inlet and the atomizer.

24. The vape device of any of claims 1-23, further comprising a light source and a light detector that form a transmissive light sensor in which light emitted from the light source is transmitted through the vaporized payload to the light detector, wherein the light source and the light detector are incorporated into a light intensity measurement circuit configured to obtain a plurality of light intensity measurements during the user inhalation, and wherein the microcontroller is programmed to determine the dose of the vaporized payload for the user inhalation based further on the plurality of light intensity measurements.

25. The vape device of any of claims 1-23, further comprising a light source and a light detector that form a reflective light sensor in which light emitted from the light source is reflected off the vaporized payload to the light detector, wherein the light source and the light detector are incorporated into a light intensity measurement circuit configured to obtain a plurality of light intensity measurements during the user inhalation, and wherein the microcontroller is programmed to determine the dose of the vaporized payload for the user inhalation based further on the plurality of light intensity measurements.

26. The vape device of any of claims 1-23, further comprising a light source and a light detector that form a light sensor in which light emitted from the light source is transmitted through a light transmitting medium positioned within the vaporized payload to the light detector, wherein the light source and the light detector are incorporated into a light intensity measurement circuit configured to obtain a plurality of light intensity measurements during the user inhalation, and wherein the microcontroller is programmed to determine the dose of the vaporized payload for the user inhalation based further on the plurality of light intensity measurements.

27. The vape device of any of claims 24-26, wherein the vape device comprises a cartridge releasably connected to a control assembly, and wherein the light source and the light detector are contained within the cartridge.

28. The vape device of any of claims 24-26, wherein the vape device comprises a cartridge releasably connected to a control assembly, and wherein the light source and the light detector are contained within the control assembly.

- 62 -

29. The vape device of any of claims 24-26, wherein the vape device comprises a cartridge releasably connected to a control assembly, and wherein the light source is contained with the control assembly and the light detector is contained within the cartridge.

30. The vape device of any of claims 24-29, wherein the light detector is configured to filter the light so as to only pass a range of light wavelengths associated with the vaporized payload.

31. The vape device of any of claims 24-30, wherein the microcontroller is programmed to vary one or both of an intensity of the light emitted by the light source and a gain of the light detector.

32. The vape device of any of claims 24-31, wherein the microcontroller is programmed to apply an electric field to the air flow chamber so as to orient a plurality of molecules in the vaporized payload when the vaporized payload passes through the air flow chamber.

33. The vape device of any of claims 1-32, further comprising at least one sampling hot wire anemometer located within the air flow chamber between the atomizer and the outlet, wherein the sampling hot wire anemometer is incorporated into a circuit configured to determine a number of droplets of the vaporized payload passing by the sampling hot wire anemometer during each respective user inhalation, and wherein the microcontroller is programmed to determine the dose of the vaporized payload for the user inhalation based further on the number of droplets of the vaporized payload.

34. The vape device of claim 33, further comprising a reference hot wire anemometer located within the air flow chamber between the inlet and the atomizer, wherein the reference hot wire anemometer is incorporated into a circuit configured to determine an air flow rate within the air flow chamber during the user inhalation, and wherein the microcontroller is programmed to determine the dose of the vaporized payload for each respective user inhalation based further on the air flow rate.

35. The vape device of any of claims 33-34, further comprising:

a first temperature sensor located within the air flow chamber between the inlet and the atomizer, wherein the first temperature sensor is incorporated into a first temperature measurement circuit configured to obtain a first plurality of temperature measurements during the user inhalation;

- 63 -

a second temperature sensor located within the air flow chamber between the atomizer and the outlet, wherein the second temperature sensor is incorporated into a second temperature measurement circuit configured to obtain a second plurality of temperature measurements during the user inhalation; and

wherein the microcontroller is programmed to determine the dose of the vaporized payload for each respective user inhalation based further on the first and second plurality of temperature measurements.

36. The vape device of claim 35, wherein each of the first and second temperature sensors comprises one of a thermistor, a thermocouple, an infrared sensor, a bandgap temperature sensor, an analog temperature sensor, or a digital temperature sensor.

37. The vape device of any of claims 33-36, wherein the payload comprises a first component having a first boiling point and a second component having a second boiling point, wherein the first boiling point is lower than the second boiling point, and wherein:

the at least one sampling hot wire anemometer comprises a first sampling hot wire anemometer and a second sampling hot wire anemometer each of which is located within the air flow chamber between the atomizer and the outlet;

the first sampling hot wire anemometer is incorporated into a first circuit configured to (a) operate the first sampling hot wire anemometer at a first temperature that is higher than the first boiling point and lower than the second boiling point and (b) determine a number of droplets of the first component passing by the first sampling hot wire anemometer, during each of a plurality of the user inhalations;

the second sampling hot wire anemometer is incorporated into a second circuit configured to (a) operate the second sampling hot wire anemometer at a second temperature that is higher than both of the first and second boiling points and (b) determine a number of droplets of the second component passing by the second sampling hot wire anemometer, during each of the plurality of the user inhalations; and

the microcontroller is programmed to determine a dose of each of the first and second components for each respective user inhalation based on the number of droplets of each of the first and second components, respectively.

38. The vape device of claim 37, wherein the operation of the first and second hot wire anemometers is reversed during each of a second plurality of the user inhalations such that:

- 64 -

the first circuit is configured to (a) operate the first sampling hot wire anemometer at the second temperature and (b) determine the number of droplets of the second component passing by the first sampling hot wire anemometer; during each of the second plurality of the user inhalations; and

the second circuit is configured to (a) operate the second sampling hot wire anemometer at the first temperature and (b) determine the number of droplets of the first component passing by the second sampling hot wire anemometer, during each of the second plurality of the user inhalations.

39. The vape device of claim 37, wherein the first circuit is configured to determine a droplet size of each of the droplets of the first component passing by the first sampling hot wire anemometer, wherein the second circuit is configured to determine a droplet size of each of the droplets of the second component passing by the second sampling hot wire anemometer, and wherein the microcontroller is programmed to determine the dose of each of the first and second components for each respective user inhalation based further on the droplet size of each of the droplets of the first and second components, respectively.

40. The vape device of any of claims 33-39, wherein each of the hot wire anemometers comprises a wire filament made of one of tungsten, platinum, or platinum-iridium.

41. The vape device of any of claims 1-40, further comprising a wireless transceiver configured to transmit the dose of the vaporized payload to an external computing device.

42. The vape device of any of claims 1-41, wherein transmission of the power signal to the atomizer is disabled when the dose of the vaporized payload reaches a specified dose.

43. The vape device of any of claims 1-42, wherein the microcontroller is programmed to determine a remaining amount of the payload in the payload reservoir based on (a) the total amount of the payload and (b) an aggregated amount of the payload that has been vaporized during the previous user inhalations.

44. The vape device of claim 43, wherein the microcontroller is programmed to determine a portion of the remaining amount of the payload in the payload reservoir that is useable for vaporization.

- 65 -

45. The vape device of any of claims 43-44, wherein the microcontroller is programmed to provide a notice when the remaining amount of the payload in the payload reservoir is below a minimum level.

46. A method for determining a dose of a payload delivered to a user of a vape device during each of a plurality of user inhalations, comprising:

holding a payload to be vaporized;

vaporizing a portion of the payload by transmitting a power signal from a power source to an atomizer located between an inlet and an outlet of an air flow chamber to thereby generate a vaporized payload during each respective user inhalation; and

determining a dose of the vaporized payload for each respective user inhalation based on: (a) determining an amount of energy used to vaporize the portion of the payload during the user inhalation; and (b) determining a partial mass of the payload that is vaporized during the user inhalation based on the amount of energy used to vaporize the portion of the payload during the user inhalation.

47. The method of claim 46, wherein the payload comprises a fluid payload or a dry material payload containing at least one of nicotine, cannabis, cannabinoid, propylene glycol, polyethylene glycol, or vegetable glycerin.

48. The method of any of claims 46-47, further comprising: (a) identifying one or more components within the payload; (b) identifying a relative percentage and a boiling point for each of the components within the payload; and (c) determining a mass of each of the components within the portion of the payload that is vaporized during the user inhalation.

49. The method of claim 48, further comprising determining an optimal vaporization temperature for the payload based on the relative percentage and the boiling point for each of the components within the payload.

50. The method of any of claims 46-49, wherein the power source comprises a battery, and wherein the power signal comprises a direct current or a pulsed direct current.

51. The method of any of claims 46-50, wherein the step of determining the amount of energy used to vaporize the portion of the payload during the user inhalation comprises: (a) determining an amount of power provided to the atomizer during the user inhalation; (b) determining a duration of the user inhalation; and (c) determining a total amount of energy

based on the amount of power provided to the atomizer during the user inhalation and the duration of the user inhalation.

52. The method of claim 51, wherein the step of determining the amount of power provided to the atomizer during the user inhalation is based on: (a) a measurement of an output voltage of the power source during the user inhalation; and (b) a measurement of a current delivered to the atomizer during the user inhalation.

53. The method of claim 51, wherein the step of determining the amount of power provided to the atomizer during the user inhalation is based on: (a) a measurement of a resistance of a path between the power source and the atomizer during the user inhalation; and (b) a measurement of an output voltage of the power source or a current delivered to the atomizer during the user inhalation.

54. The method of any of claims 51-53, wherein the step of determining the amount of energy used to vaporize the portion of the payload during the user inhalation further comprises: (a) determining an amount of energy used to heat the atomizer to a vaporization temperature during the user inhalation; and (b) adjusting the total amount of energy by subtracting the amount of energy used to heat the atomizer to the vaporization temperature during the user inhalation.

55. The method of any of claims 51-54, wherein the step of determining the amount of energy used to vaporize the portion of the payload during the user inhalation further comprises adjusting the total amount of energy to account for one or more of the following operating conditions: a starting temperature of the vape device, a starting temperature of the payload, a temperature of ambient air, a relative humidity of ambient air, a pressure of ambient air, an output voltage of the power source, and a temperature ramp rate of the atomizer.

56. The method of any of claims 51-55, wherein the step of determining the amount of energy used to vaporize the portion of the payload during the user inhalation further comprises: (a) determining an air flow rate within the air flow chamber during the user inhalation; and (b) adjusting the total amount of energy to account for the air flow rate.

57. The method of claim 56, wherein the air flow chamber defines an orifice having a cross-sectional area, and wherein the step of determining the air flow rate within the air flow chamber

- 67 -

during the user inhalation is based on: (a) a pressure difference across the orifice during the user inhalation; and (b) the cross-sectional area of the orifice.

58. The method of claim 57, wherein the pressure difference across the orifice during the user inhalation is based on:

obtaining a first plurality of pressure measurements on a first side of the orifice during the user inhalation;

obtaining a second plurality of pressure measurements on a second opposing side of the orifice during the user inhalation; and

determining the pressure difference across the orifice during the user inhalation based on the first and second plurality of pressure measurements.

59. The method of claim 57, wherein the pressure difference across the orifice during the user inhalation is based on:

obtaining a plurality of pressure measurements on a side of the orifice before and during the user inhalation; and

determining the pressure difference across the orifice during the user inhalation based on the plurality of pressure measurements.

60. The method of claim 57, wherein the pressure difference across the orifice during the user inhalation is based on:

obtaining a plurality of pressure measurements on a side of the orifice during and after the user inhalation; and

determining the pressure difference across the orifice during the user inhalation based on the plurality of pressure measurements.

61. The method of claim 57, wherein the pressure difference across the orifice during the user inhalation is based on:

obtaining a plurality of pressure measurements on a side of the orifice before, during, and after the user inhalation; and

determining the pressure difference across the orifice during the user inhalation based on the plurality of pressure measurements.

62. The method of any of claims 46-61, further comprising:

obtaining a first plurality of temperature measurements within the air flow chamber between the inlet and the atomizer during the user inhalation;

- 68 -

obtaining a second plurality of temperature measurements within the air flow chamber between the atomizer and the outlet during the user inhalation; and

wherein the step of determining the dose of the vaporized payload for the user inhalation is based further on: (a) the first and second plurality of temperature measurements; and (b) the air flow rate within the air flow chamber during the user inhalation.

63. The method of any of claims 56-62, wherein the step of determining the dose of the vaporized payload for the user inhalation is based further on an air moisture content and an atmospheric pressure within the air flow chamber between the inlet and the atomizer.

64. The method of any of claims 46-63, further comprising:

obtaining a plurality of light intensity measurements during the user inhalation, wherein the light intensity measurements are associated with light that is transmitted through the vaporized payload, reflected off the vaporized payload, or transmitted through a light transmitting medium positioned within the vaporized payload, when the vaporized payload passes through the air flow chamber; and

wherein the step of determining the dose of the vaporized payload for the user inhalation is based further on the plurality of light intensity measurements.

65. The method of claim 64, further comprising filtering the light reflected off the vaporized payload so as to only pass a range of light wavelengths associated with the vaporized payload.

66. The method of any of claims 64-65, further comprising applying an electric field to the air flow chamber so as to orient a plurality of molecules in the vaporized payload when the vaporized payload passes through the air flow chamber.

67. The method of any of claims 46-66, further comprising:

determining a number of droplets of the vaporized payload passing by at least one sampling hot wire anemometer located within the air flow chamber between the atomizer and the outlet during each respective user inhalation; and

wherein the step of determining the dose of the vaporized payload for the user inhalation is based further on the number of droplets of the vaporized payload.

68. The method of claim 67, further comprising determining an air flow rate within the air flow chamber during the user inhalation using a reference hot wire anemometer located within

- 69 -

the air flow chamber between the inlet and the atomizer, and wherein the step of determining the dose of the vaporized payload for each respective user inhalation is based further on the air flow rate.

69. The method of any of claims 67-68, further comprising:

obtaining a first plurality of temperature measurements within the air flow chamber between the inlet and the atomizer during the user inhalation;

obtaining a second plurality of temperature measurements within the air flow chamber between the atomizer and the outlet during the user inhalation; and

wherein the step of determining the dose of the vaporized payload for each respective user inhalation is based further on the first and second plurality of temperature measurements.

70. The method of any of claims 67-69, wherein the payload comprises a first component having a first boiling point and a second component having a second boiling point, wherein the first boiling point is lower than the second boiling point, wherein the at least one sampling hot wire anemometer comprises a first sampling hot wire anemometer and a second sampling hot wire anemometer each of which is located within the air flow chamber between the atomizer and the outlet, and wherein the method further comprises performing the following steps during each of a plurality of the user inhalations:

operating the first sampling hot wire anemometer at a first temperature that is higher than the first boiling point and lower than the second boiling point;

determining a number of droplets of the first component passing by the first sampling hot wire anemometer;

operating the second sampling hot wire anemometer at a second temperature that is higher than both of the first and second boiling points;

determining a number of droplets of the second component passing by the second sampling hot wire anemometer; and

wherein the step of determining the dose of the vaporized payload comprises determining a dose of each of the first and second components based on the number of droplets of each of the first and second components, respectively.

71. The method of claim 70, wherein the operation of the first and second hot wire anemometers is reversed during each of a second plurality of the user inhalations to comprise the steps of:

operating the first sampling hot wire anemometer at the second temperature;

- 70 -

determining the number of droplets of the second component passing by the first sampling hot wire anemometer;

operating the second sampling hot wire anemometer at the first temperature; and

determining the number of droplets of the first component passing by the second sampling hot wire anemometer.

72. The method of claim 70, further comprising:

determining a droplet size of each of the droplets of the first component passing by the first sampling hot wire anemometer;

determining a droplet size of each of the droplets of the second component passing by the second sampling hot wire anemometer; and

wherein the step of determining the dose of each of the first and second components is based further on the droplet size of each of the droplets of the first and second components, respectively.

73. The method of any of claims 46-72, further comprising transmitting the dose of the vaporized payload to an external computing device.

74. The method of any of claims 46-73, further comprising disabling transmission of the power signal to the atomizer when the dose of the vaporized payload reaches a specified dose.

75. The method of any of claims 46-74, further comprising determining a remaining amount of the payload in the payload reservoir based on (a) the total amount of the payload and (b) an aggregated amount of the payload that has been vaporized during the previous user inhalations.

76. The method of claim 75, further comprising determining a portion of the remaining amount of the payload in the payload reservoir that is useable for vaporization.

77. The method of any of claims 75-76, further comprising providing a notice when the remaining amount of the payload in the payload reservoir is below a minimum level.

78. A vape device for determining a dose of a payload delivered to a user during each of a plurality of user inhalations, comprising:

a payload reservoir configured to contain a payload to be vaporized;

an air flow chamber that extends between an inlet and an outlet;

- 71 -

an atomizer located between the inlet and the outlet of the air flow chamber, wherein the atomizer is configured to vaporize a portion of the payload to thereby generate a vaporized payload during each respective user inhalation; and

a microcontroller programmed to determine a dose of the vaporized payload for each respective user inhalation based on: (a) a plurality of temperature measurements obtained within the air flow chamber during the user inhalation; and (b) an air flow rate within the air flow chamber during the user inhalation.

79. The vape device of claim 78, further comprising:

a first temperature sensor located within the air flow chamber between the inlet and the atomizer, wherein the first temperature sensor is incorporated into a first temperature measurement circuit configured to obtain a first plurality of temperature measurements during the user inhalation;

a second temperature sensor located within the air flow chamber between the atomizer and the outlet, wherein the second temperature sensor is incorporated into a second temperature measurement circuit configured to obtain a second plurality of temperature measurements during the user inhalation; and

wherein the plurality of temperature measurements comprise the first and second plurality of temperature measurements.

80. The vape device of claim 79, wherein each of the first and second temperature sensors comprises one of a thermistor, a thermocouple, an infrared sensor, a bandgap temperature sensor, an analog temperature sensor, or a digital temperature sensor.

81. The vape device of any of claims 78-80, wherein the microcontroller is programmed to determine the dose of the vaporized payload for the user inhalation based further on an air moisture content and an atmospheric pressure within the air flow chamber between the inlet and the atomizer.

82. The vape device of any of claims 78-81, wherein the air flow chamber defines an orifice having a cross-sectional area, and wherein the microcontroller is programmed to determine the air flow rate within the air flow chamber during the user inhalation based on: (a) a pressure difference across the orifice during the user inhalation; and (b) the cross-sectional area of the orifice.

83. The vape device of claim 82, further comprising:

- 72 -

a first pressure sensor located on a first side of the orifice, wherein the first pressure sensor is incorporated into a first pressure measurement circuit configured to obtain a first plurality of pressure measurements during the user inhalation;

a second pressure sensor located on a second opposing side of the orifice, wherein the second pressure sensor is incorporated into a second pressure measurement circuit configured to obtain a second plurality of pressure measurements during the user inhalation; and

wherein the pressure difference across the orifice during the user inhalation is based on the first and second plurality of pressure measurements.

84. The vape device of claim 82, further comprising:

a pressure sensor located on a side of the orifice, wherein the pressure sensor is incorporated into a pressure measurement circuit configured to obtain a plurality of pressure measurements before and during the user inhalation; and

wherein the pressure difference across the orifice during the user inhalation is based on the plurality of the pressure measurements.

85. The vape device of claim 82, further comprising:

a pressure sensor located on a side of the orifice, wherein the pressure sensor is incorporated into a pressure measurement circuit configured to obtain a plurality of pressure measurements during and after the user inhalation; and

wherein the pressure difference across the orifice during the user inhalation is based on the plurality of pressure measurements.

86. The vape device of claim 82, further comprising:

a pressure sensor located on a side of the orifice, wherein the pressure sensor is incorporated into a pressure measurement circuit configured to obtain a plurality of pressure measurements before, during, and after the user inhalation; and

wherein the pressure difference across the orifice during the user inhalation is based on the plurality of pressure measurements.

87. The vape device of any of claims 78-86, wherein the microcontroller is programmed to determine the dose of the vaporized payload for the respective user inhalation based further on:

(a) determining an amount of energy used to vaporize the portion of the payload during the user inhalation; and (b) determining a partial mass of the payload that is vaporized during the

- 73 -

user inhalation based on the amount of energy used to vaporize the portion of the payload during the user inhalation.

88. The vape device of claim 87, wherein the payload comprises a fluid payload or a dry material payload containing at least one of nicotine, cannabis, cannabinoid, propylene glycol, polyethylene glycol, or vegetable glycerin.

89. The vape device of any of claims 87-88, wherein the microcontroller is further programmed to: (a) identify one or more components within the payload; (b) identify a relative percentage and a boiling point for each of the components within the payload; and (c) determine a mass of each of the components within the portion of the payload that is vaporized during the user inhalation.

90. The vape device of claim 89, wherein the microcontroller is further programmed to determine an optimal vaporization temperature for the payload based on the relative percentage and the boiling point for each of the components within the payload.

91. The vape device of any of claims 87-90, further comprising a power source configured to generate a power signal during each user inhalation.

92. The vape device of any of claims 87-91, further comprising a memory device configured to store information that enables the microcontroller to correlate the amount of energy used to vaporize the portion of the payload during the user inhalation to the partial mass of the payload that is vaporized during the user inhalation.

93. The vape device of any of claims 87-92, wherein the vape device comprises a cartridge releasably connected to a control assembly, and wherein the microcontroller is contained within the control assembly.

94. The vape device of any of claims 87-92, wherein the vape device comprises a cartridge releasably connected to a control assembly, and wherein the microcontroller is contained within the cartridge.

95. The vape device of any of claims 91-94, wherein the power source comprises a battery, and wherein the power signal comprises a direct current or a pulsed direct current.

96. The vape device of any of claims 87-95, wherein the microcontroller is programmed to determine the amount of energy used to vaporize the portion of the payload during the user

- 74 -

inhalation based on: (a) determining an amount of power provided to the atomizer during the user inhalation; (b) determining a duration of the user inhalation; and (c) determining a total amount of energy based on the amount of power provided to the atomizer during the user inhalation and the duration of the user inhalation.

97. The vape device of claim 96, wherein the microcontroller is programmed to determine the amount of power provided to the atomizer during the user inhalation based on: (a) a measurement of an output voltage of the power source during the user inhalation; and (b) a measurement of a current delivered to the atomizer during the user inhalation.

98. The vape device of claim 96, wherein the microcontroller is programmed to determine the amount of power provided to the atomizer during the user inhalation based on: (a) a measurement of a resistance of a path between the power source and the atomizer during the user inhalation; and (b) a measurement of an output voltage of the power source or a measurement of a current delivered to the atomizer during the user inhalation.

99. The vape device of any of claims 96-98, wherein the microcontroller is further programmed to determine the amount of energy used to vaporize the portion of the payload during the user inhalation based on: (a) determining an amount of energy used to heat the atomizer to a vaporization temperature during the user inhalation; and (b) adjusting the total amount of energy by subtracting the amount of energy used to heat the atomizer to the vaporization temperature during the user inhalation.

100. The vape device of any of any of claims 96-99, wherein the microcontroller is further programmed to determine the amount of energy used to vaporize the portion of the payload during the user inhalation by adjusting the total amount of energy to account for one or more of the following operating conditions: a starting temperature of the vape device, a starting temperature of the payload, a temperature of ambient air, a relative humidity of ambient air, a pressure of ambient air, an output voltage of the power source, and a temperature ramp rate of the atomizer.

101. The vape device of any of claims 96-100, wherein the microcontroller is further programmed to determine the amount of energy used to vaporize the portion of the payload during the user inhalation by adjusting the total amount of energy to account for the air flow rate within the air flow chamber during the user inhalation.

- 75 -

102. The vape device of any of claims 78-101, further comprising a light source and a light detector that form a transmissive light sensor in which light emitted from the light source is transmitted through the vaporized payload to the light detector, wherein the light source and the light detector are incorporated into a light intensity measurement circuit configured to obtain a plurality of light intensity measurements during the user inhalation, and wherein the microcontroller is programmed to determine the dose of the vaporized payload for the user inhalation based further on the plurality of light intensity measurements.

103. The vape device of any of claims 78-101, further comprising a light source and a light detector that form a reflective light sensor in which light emitted from the light source is reflected off the vaporized payload to the light detector, wherein the light source and the light detector are incorporated into a light intensity measurement circuit configured to obtain a plurality of light intensity measurements during the user inhalation, and wherein the microcontroller is programmed to determine the dose of the vaporized payload for the user inhalation based further on the plurality of light intensity measurements.

104. The vape device of any of claims 78-101, further comprising a light source and a light detector that form a light sensor in which light emitted from the light source is transmitted through a light transmitting medium positioned within the vaporized payload to the light detector, wherein the light source and the light detector are incorporated into a light intensity measurement circuit configured to obtain a plurality of light intensity measurements during the user inhalation, and wherein the microcontroller is programmed to determine the dose of the vaporized payload for the user inhalation based further on the plurality of light intensity measurements.

105. The vape device of any of claims 102-104, wherein the vape device comprises a cartridge releasably connected to a control assembly, and wherein the light source and the light detector are contained within the cartridge.

106. The vape device of any of claims 102-104, wherein the vape device comprises a cartridge releasably connected to a control assembly, and wherein the light source and the light detector are contained within the control assembly.

107. The vape device of any of claims 102-104, wherein the vape device comprises a cartridge releasably connected to a control assembly, and wherein the light source is contained with the control assembly and the light detector is contained within the cartridge.

- 76 -

108. The vape device of any of claims 102-107, wherein the light detector is configured to filter the light so as to only pass a range of light wavelengths associated with the vaporized payload.

109. The vape device of any of claims 102-108, wherein the microcontroller is programmed to vary one or both of an intensity of the light emitted by the light source and a gain of the light detector.

110. The vape device of any of claims 102-109, wherein the microcontroller is programmed to apply an electric field to the air flow chamber so as to orient a plurality of molecules in the vaporized payload when the vaporized payload passes through the air flow chamber.

111. The vape device of any of claims 78-110, further comprising at least one sampling hot wire anemometer located within the air flow chamber between the atomizer and the outlet, wherein the sampling hot wire anemometer is incorporated into a circuit configured to determine a number of droplets of the vaporized payload passing by the sampling hot wire anemometer during each respective user inhalation, and wherein the microcontroller is programmed to determine the dose of the vaporized payload for the user inhalation based further on the number of droplets of the vaporized payload.

112. The vape device of claim 111, further comprising a reference hot wire anemometer located within the air flow chamber between the inlet and the atomizer, wherein the reference hot wire anemometer is incorporated into a circuit configured to determine an air flow rate within the air flow chamber during the user inhalation, and wherein the microcontroller is programmed to determine the dose of the vaporized payload for each respective user inhalation based further on the air flow rate.

113. The vape device of any of claims 110-111, further comprising:

a first temperature sensor located within the air flow chamber between the inlet and the atomizer, wherein the first temperature sensor is incorporated into a first temperature measurement circuit configured to obtain a first plurality of temperature measurements during the user inhalation;

a second temperature sensor located within the air flow chamber between the atomizer and the outlet, wherein the second temperature sensor is incorporated into a second temperature measurement circuit configured to obtain a second plurality of temperature measurements during the user inhalation; and

- 77 -

wherein the microcontroller is programmed to determine the dose of the vaporized payload for each respective user inhalation based further on the first and second plurality of temperature measurements.

114. The vape device of claim 113, wherein each of the first and second temperature sensors comprises one of a thermistor, a thermocouple, an infrared sensor, a bandgap temperature sensor, an analog temperature sensor, or a digital temperature sensor.

115. The vape device of any of claims 111-114, wherein the payload comprises a first component having a first boiling point and a second component having a second boiling point, wherein the first boiling point is lower than the second boiling point, and wherein:

the at least one sampling hot wire anemometer comprises a first sampling hot wire anemometer and a second sampling hot wire anemometer each of which is located within the air flow chamber between the atomizer and the outlet;

the first sampling hot wire anemometer is incorporated into a first circuit configured to (a) operate the first sampling hot wire anemometer at a first temperature that is higher than the first boiling point and lower than the second boiling point and (b) determine a number of droplets of the first component passing by the first sampling hot wire anemometer, during each of a plurality of the user inhalations;

the second sampling hot wire anemometer is incorporated into a second circuit configured to (a) operate the second sampling hot wire anemometer at a second temperature that is higher than both of the first and second boiling points and (b) determine a number of droplets of the second component passing by the second sampling hot wire anemometer, during each of the plurality of the user inhalations; and

the microcontroller is programmed to determine a dose of each of the first and second components for each respective user inhalation based on the number of droplets of each of the first and second components, respectively.

116. The vape device of claim 115, wherein the operation of the first and second hot wire anemometers is reversed during each of a second plurality of the user inhalations such that:

the first circuit is configured to (a) operate the first sampling hot wire anemometer at the second temperature and (b) determine the number of droplets of the second component passing by the first sampling hot wire anemometer; during each of the second plurality of the user inhalations; and

- 78 -

the second circuit is configured to (a) operate the second sampling hot wire anemometer at the first temperature and (b) determine the number of droplets of the first component passing by the second sampling hot wire anemometer, during each of the second plurality of the user inhalations.

117. The vape device of claim 115, wherein the first circuit is configured to determine a droplet size of each of the droplets of the first component passing by the first sampling hot wire anemometer, wherein the second circuit is configured to determine a droplet size of each of the droplets of the second component passing by the second sampling hot wire anemometer, and wherein the microcontroller is programmed to determine the dose of each of the first and second components for each respective user inhalation based further on the droplet size of each of the droplets of the first and second components, respectively.

118. The vape device of any of claims 111-117, wherein each of the hot wire anemometers comprises a wire filament made of one of tungsten, platinum, or platinum-iridium.

119. The vape device of any of claims 78-118, further comprising a wireless transceiver configured to transmit the dose of the vaporized payload to an external computing device.

120. The vape device of any of claims 78-119, wherein transmission of the power signal to the atomizer is disabled when the dose of the vaporized payload reaches a specified dose.

121. The vape device of any of claims 78-120, wherein the microcontroller is programmed to determine a remaining amount of the payload in the payload reservoir based on (a) the total amount of the payload and (b) an aggregated amount of the payload that has been vaporized during the previous user inhalations.

122. The vape device of claim 121, wherein the microcontroller is programmed to determine a portion of the remaining amount of the payload in the payload reservoir that is useable for vaporization.

123. The vape device of any of claims 121-122, wherein the microcontroller is programmed to provide a notice when the remaining amount of the payload in the payload reservoir is below a minimum level.

- 79 -

124. A method for determining a dose of a payload delivered to a user of a vape device during each of a plurality of user inhalations, comprising:

holding a payload to be vaporized;

vaporizing a portion of the payload with an atomizer located between an inlet and an outlet of an air flow chamber to thereby generate a vaporized payload during each respective user inhalation; and

determining a dose of the vaporized payload for each respective user inhalation based on: (a) a plurality of temperature measurements obtained within the air flow chamber during the user inhalation; and (b) an air flow rate within the air flow chamber during the user inhalation.

125. The method of claim 124, further comprising:

obtaining a first plurality of temperature measurements within the air flow chamber between the inlet and the atomizer during the user inhalation;

obtaining a second plurality of temperature measurements within the air flow chamber between the atomizer and the outlet during the user inhalation; and

wherein the plurality of temperature measurements comprise the first and second plurality of temperature measurements.

126. The method of any of claims 124-125, wherein the step of determining the dose of the vaporized payload for the user inhalation is based further on an air moisture content and an atmospheric pressure within the air flow chamber between the inlet and the atomizer.

127. The method of claim 124-126, wherein the air flow chamber defines an orifice having a cross-sectional area, and wherein the step of determining the air flow rate within the air flow chamber during the user inhalation is based on: (a) a pressure difference across the orifice during the user inhalation; and (b) the cross-sectional area of the orifice.

128. The method of claim 127, wherein the pressure difference across the orifice during the user inhalation is based on:

obtaining a first plurality of pressure measurements on a first side of the orifice during the user inhalation;

obtaining a second plurality of pressure measurements on a second opposing side of the orifice during the user inhalation; and

- 80 -

determining the pressure difference across the orifice during the user inhalation based on the first and second plurality of pressure measurements.

129. The method of claim 127, wherein the pressure difference across the orifice during the user inhalation is based on:

obtaining a plurality of pressure measurements on a side of the orifice before and during the user inhalation; and

determining the pressure difference across the orifice during the user inhalation based on the plurality of pressure measurements.

130. The method of claim 127, wherein the pressure difference across the orifice during the user inhalation is based on:

obtaining a plurality of pressure measurements on a side of the orifice during and after the user inhalation; and

determining the pressure difference across the orifice during the user inhalation based on the plurality of pressure measurements.

131. The method of claim 127, wherein the pressure difference across the orifice during the user inhalation is based on:

obtaining a plurality of pressure measurements on a side of the orifice before, during, and after the user inhalation; and

determining the pressure difference across the orifice during the user inhalation based on the plurality of pressure measurements.

132. The method of any of claims 124-131, wherein the step of determining the dose of the vaporized payload for the user inhalation is based further on: (a) determining an amount of energy used to vaporize the portion of the payload during the user inhalation; and (b) determining a partial mass of the payload that is vaporized during the user inhalation based on the amount of energy used to vaporize the portion of the payload during the user inhalation.

133. The method of claim 132, wherein the payload comprises a fluid payload or a dry material payload containing at least one of nicotine, cannabis, cannabinoid, propylene glycol, polyethylene glycol, or vegetable glycerin.

134. The method of any of claims 132-133, further comprising: (a) identifying one or more components within the payload; (b) identifying a relative percentage and a boiling point for

- 81 -

each of the components within the payload; and (c) determining a mass of each of the components within the portion of the payload that is vaporized during the user inhalation.

135. The method of claim 134, further comprising determining an optimal vaporization temperature for the payload based on the relative percentage and the boiling point for each of the components within the payload.

136. The method of any of claims 124-135, further comprising transmitting a power signal from a power source to the atomizer during each user inhalation.

137. The method of claim 136, wherein the step of determining the amount of energy used to vaporize the portion of the payload during the user inhalation comprises: (a) determining an amount of power provided to the atomizer during the user inhalation; (b) determining a duration of the user inhalation; and (c) determining a total amount of energy based on the amount of power provided to the atomizer during the user inhalation and the duration of the user inhalation.

138. The method of claim 137, wherein the step of determining the amount of power provided to the atomizer during the user inhalation is based on: (a) a measurement of an output voltage of the power source during the user inhalation; and (b) a measurement of a current delivered to the atomizer during the user inhalation.

139. The method of claim 137, wherein the step of determining the amount of power provided to the atomizer during the user inhalation is based on: (a) a measurement of a resistance of a path between the power source and the atomizer during the user inhalation; and (b) a measurement of an output voltage of the power source or a current delivered to the atomizer during the user inhalation.

140. The method of any of claims 136-139, wherein the step of determining the amount of energy used to vaporize the portion of the payload during the user inhalation further comprises: (a) determining an amount of energy used to heat the atomizer to a vaporization temperature during the user inhalation; and (b) adjusting the total amount of energy by subtracting the amount of energy used to heat the atomizer to the vaporization temperature during the user inhalation.

141. The method of any of claims 136-140, wherein the step of determining the amount of energy used to vaporize the portion of the payload during the user inhalation further comprises

- 82 -

adjusting the total amount of energy to account for one or more of the following operating conditions: a starting temperature of the vape device, a starting temperature of the payload, a temperature of ambient air, a relative humidity of ambient air, a pressure of ambient air, an output voltage of the power source, and a temperature ramp rate of the atomizer.

142. The method of any of claims 136-141, wherein the step of determining the amount of energy used to vaporize the portion of the payload during the user inhalation further comprises adjusting the total amount of energy to account for the air flow rate within the air flow chamber during the user inhalation.

143. The method of any of claims 124-142, further comprising:

obtaining a plurality of light intensity measurements during the user inhalation, wherein the light intensity measurements are associated with light that is transmitted through the vaporized payload, reflected off the vaporized payload, or transmitted through a light transmitting medium positioned within the vaporized payload, when the vaporized payload passes through the air flow chamber; and

wherein the step of determining the dose of the vaporized payload for the user inhalation is based further on the plurality of light intensity measurements.

144. The method of claim 143, further comprising filtering the light reflected off the vaporized payload so as to only pass a range of light wavelengths associated with the vaporized payload.

145. The method of any of claims 143-144, further comprising applying an electric field to the air flow chamber so as to orient a plurality of molecules in the vaporized payload when the vaporized payload passes through the air flow chamber.

146. The method of any of claims 124-145, further comprising:

determining a number of droplets of the vaporized payload passing by at least one sampling hot wire anemometer located within the air flow chamber between the atomizer and the outlet during each respective user inhalation; and

wherein the step of determining the dose of the vaporized payload for the user inhalation is based further on the number of droplets of the vaporized payload.

147. The method of claim 146, further comprising determining an air flow rate within the air flow chamber during the user inhalation using a reference hot wire anemometer located

- 83 -

within the air flow chamber between the inlet and the atomizer, and wherein the step of determining the dose of the vaporized payload for each respective user inhalation is based further on the air flow rate.

148. The method of any of claims 146-147, further comprising:

obtaining a first plurality of temperature measurements within the air flow chamber between the inlet and the atomizer during the user inhalation;

obtaining a second plurality of temperature measurements within the air flow chamber between the atomizer and the outlet during the user inhalation; and

wherein the step of determining the dose of the vaporized payload for each respective user inhalation is based further on the first and second plurality of temperature measurements.

149. The method of any of claims 146-148, wherein the payload comprises a first component having a first boiling point and a second component having a second boiling point, wherein the first boiling point is lower than the second boiling point, wherein the at least one sampling hot wire anemometer comprises a first sampling hot wire anemometer and a second sampling hot wire anemometer each of which is located within the air flow chamber between the atomizer and the outlet, and wherein the method further comprises performing the following steps during each of a plurality of the user inhalations:

operating the first sampling hot wire anemometer at a first temperature that is higher than the first boiling point and lower than the second boiling point;

determining a number of droplets of the first component passing by the first sampling hot wire anemometer;

operating the second sampling hot wire anemometer at a second temperature that is higher than both of the first and second boiling points;

determining a number of droplets of the second component passing by the second sampling hot wire anemometer; and

wherein the step of determining the dose of the vaporized payload comprises determining a dose of each of the first and second components based on the number of droplets of each of the first and second components, respectively.

150. The method of claim 149, wherein the operation of the first and second hot wire anemometers is reversed during each of a second plurality of the user inhalations to comprise the steps of:

operating the first sampling hot wire anemometer at the second temperature;

- 84 -

determining the number of droplets of the second component passing by the first sampling hot wire anemometer;

operating the second sampling hot wire anemometer at the first temperature; and

determining the number of droplets of the first component passing by the second sampling hot wire anemometer.

151. The method of claim 149, further comprising:

determining a droplet size of each of the droplets of the first component passing by the first sampling hot wire anemometer;

determining a droplet size of each of the droplets of the second component passing by the second sampling hot wire anemometer; and

wherein the step of determining the dose of each of the first and second components is based further on the droplet size of each of the droplets of the first and second components, respectively.

152. The method of any of claims 124-151, further comprising transmitting the dose of the vaporized payload to an external computing device.

153. The method of any of claims 124-152, further comprising disabling transmission of the power signal to the atomizer when the dose of the vaporized payload reaches a specified dose.

154. The method of any of claims 124-153, further comprising determining a remaining amount of the payload in the payload reservoir based on (a) the total amount of the payload and (b) an aggregated amount of the payload that has been vaporized during the previous user inhalations.

155. The method of claim 154, further comprising determining a portion of the remaining amount of the payload in the payload reservoir that is useable for vaporization.

156. The method of any of claims 154-155, further comprising providing a notice when the remaining amount of the payload in the payload reservoir is below a minimum level.

157. A vape device for determining a dose of a payload delivered to a user during each of a plurality of user inhalations, comprising:

a payload reservoir configured to contain a payload to be vaporized;

an air flow chamber that extends between an inlet and an outlet;

- 85 -

an atomizer located between the inlet and the outlet of the air flow chamber, wherein the atomizer is configured to vaporize a portion of the payload to thereby generate a vaporized payload during each respective user inhalation;

a light source and a light detector incorporated into a light intensity measurement circuit configured to obtain a plurality of light intensity measurements during each respective user inhalation; and

a microcontroller programmed to determine a dose of the vaporized payload for each respective user inhalation based on the light intensity measurements.

158. The vape device claim 157, wherein the light source and the light detector form a transmissive light sensor in which light emitted from the light source is transmitted through the vaporized payload to the light detector.

159. The vape device of claim 157, wherein the light source and the light detector form a reflective light sensor in which light emitted from the light source is reflected off the vaporized payload to the light detector.

160. The vape device of claim 157, wherein the light source and the light detector form a light sensor in which light emitted from the light source is transmitted through a light transmitting medium positioned within the vaporized payload to the light detector.

161. The vape device of any of claims 157-160, wherein the vape device comprises a cartridge releasably connected to a control assembly, and wherein the light source and the light detector are contained within the cartridge.

162. The vape device of any of claims 157-160, wherein the vape device comprises a cartridge releasably connected to a control assembly, and wherein the light source and the light detector are contained within the control assembly.

163. The vape device of any of claims 157-160, wherein the vape device comprises a cartridge releasably connected to a control assembly, and wherein the light source is contained with the control assembly and the light detector is contained within the cartridge.

164. The vape device of any of claims 157-163, wherein the light detector is configured to filter the light so as to only pass a range of light wavelengths associated with the vaporized payload.

- 86 -

165. The vape device of any of claims 157-164, wherein the microcontroller is programmed to vary one or both of an intensity of the light emitted by the light source and a gain of the light detector.

166. The vape device of any of claims 157-165, wherein the microcontroller is programmed to apply an electric field to the air flow chamber so as to orient a plurality of molecules in the vaporized payload when the vaporized payload passes through the air flow chamber.

167. The vape device of any of claims 157-166, wherein the microcontroller is programmed to determine the dose of the vaporized payload for each user inhalation based further on: (a) a plurality of temperature measurements obtained within the air flow chamber during the user inhalation; and (b) an air flow rate within the air flow chamber during the user inhalation.

168. The vape device of claim 167, further comprising:

a first temperature sensor located within the air flow chamber between the inlet and the atomizer, wherein the first temperature sensor is incorporated into a first temperature measurement circuit configured to obtain a first plurality of temperature measurements during the user inhalation;

a second temperature sensor located within the air flow chamber between the atomizer and the outlet, wherein the second temperature sensor is incorporated into a second temperature measurement circuit configured to obtain a second plurality of temperature measurements during the user inhalation; and

wherein the plurality of temperature measurements comprise the first and second plurality of temperature measurements.

169. The vape device of claim 168, wherein each of the first and second temperature sensors comprises one of a thermistor, a thermocouple, an infrared sensor, a bandgap temperature sensor, an analog temperature sensor, or a digital temperature sensor.

170. The vape device of any of claims 167-168, wherein the microcontroller is programmed to determine the dose of the vaporized payload for the user inhalation based further on an air moisture content and an atmospheric pressure within the air flow chamber between the inlet and the atomizer.

171. The vape device of any of claims 167-170, wherein the air flow chamber defines an orifice having a cross-sectional area, and wherein the microcontroller is programmed to

- 87 -

determine the air flow rate within the air flow chamber during the user inhalation based on: (a) a pressure difference across the orifice during the user inhalation; and (b) the cross-sectional area of the orifice.

172. The vape device of claim 171, further comprising:

a first pressure sensor located on a first side of the orifice, wherein the first pressure sensor is incorporated into a first pressure measurement circuit configured to obtain a first plurality of pressure measurements during the user inhalation;

a second pressure sensor located on a second opposing side of the orifice, wherein the second pressure sensor is incorporated into a second pressure measurement circuit configured to obtain a second plurality of pressure measurements during the user inhalation; and

wherein the pressure difference across the orifice during the user inhalation is based on the first and second plurality of pressure measurements.

173. The vape device of claim 171, further comprising:

a pressure sensor located on a side of the orifice, wherein the pressure sensor is incorporated into a pressure measurement circuit configured to obtain a plurality of pressure measurements before and during the user inhalation; and

wherein the pressure difference across the orifice during the user inhalation is based on the plurality of the pressure measurements.

174. The vape device of claim 171, further comprising:

a pressure sensor located on a side of the orifice, wherein the pressure sensor is incorporated into a pressure measurement circuit configured to obtain a plurality of pressure measurements during and after the user inhalation; and

wherein the pressure difference across the orifice during the user inhalation is based on the plurality of pressure measurements.

175. The vape device of claim 171, further comprising:

a pressure sensor located on a side of the orifice, wherein the pressure sensor is incorporated into a pressure measurement circuit configured to obtain a plurality of pressure measurements before, during, and after the user inhalation; and

wherein the pressure difference across the orifice during the user inhalation is based on the plurality of pressure measurements.

- 88 -

176. The vape device of any of claims 157-175, wherein the microcontroller is programmed to determine the dose of the vaporized payload for the respective user inhalation based further on: (a) determining an amount of energy used to vaporize the portion of the payload during the user inhalation; and (b) determining a partial mass of the payload that is vaporized during the user inhalation based on the amount of energy used to vaporize the portion of the payload during the user inhalation.

177. The vape device of claim 176, wherein the payload comprises a fluid payload or a dry material payload containing at least one of nicotine, cannabis, cannabinoid, propylene glycol, polyethylene glycol, or vegetable glycerin.

178. The vape device of any of claims 176-177, wherein the microcontroller is further programmed to: (a) identify one or more components within the payload; (b) identify a relative percentage and a boiling point for each of the components within the payload; and (c) determine a mass of each of the components within the portion of the payload that is vaporized during the user inhalation.

179. The vape device of claim 178, wherein the microcontroller is further programmed to determine an optimal vaporization temperature for the payload based on the relative percentage and the boiling point for each of the components within the payload.

180. The vape device of any of claims 176-179, further comprising a power source configured to generate a power signal during each user inhalation.

181. The vape device of any of claims 176-180, further comprising a memory device configured to store information that enables the microcontroller to correlate the amount of energy used to vaporize the portion of the payload during the user inhalation to the partial mass of the payload that is vaporized during the user inhalation.

182. The vape device of any of claims 176-181, wherein the vape device comprises a cartridge releasably connected to a control assembly, and wherein the microcontroller is contained within the control assembly.

183. The vape device of any of claims 176-181, wherein the vape device comprises a cartridge releasably connected to a control assembly, and wherein the microcontroller is contained within the cartridge.

184. The vape device of any of claims 176-183, wherein the power source comprises a battery, and wherein the power signal comprises a direct current or a pulsed direct current.

185. The vape device of any of claims 176-184, wherein the microcontroller is programmed to determine the amount of energy used to vaporize the portion of the payload during the user inhalation based on: (a) determining an amount of power provided to the atomizer during the user inhalation; (b) determining a duration of the user inhalation; and (c) determining a total amount of energy based on the amount of power provided to the atomizer during the user inhalation and the duration of the user inhalation.

186. The vape device of claim 185, wherein the microcontroller is programmed to determine the amount of power provided to the atomizer during the user inhalation based on: (a) a measurement of an output voltage of the power source during the user inhalation; and (b) a measurement of a current delivered to the atomizer during the user inhalation.

187. The vape device of claim 185, wherein the microcontroller is programmed to determine the amount of power provided to the atomizer during the user inhalation based on: (a) a measurement of a resistance of a path between the power source and the atomizer during the user inhalation; and (b) a measurement of an output voltage of the power source or a measurement of a current delivered to the atomizer during the user inhalation.

188. The vape device of any of claims 185-187, wherein the microcontroller is further programmed to determine the amount of energy used to vaporize the portion of the payload during the user inhalation based on: (a) determining an amount of energy used to heat the atomizer to a vaporization temperature during the user inhalation; and (b) adjusting the total amount of energy by subtracting the amount of energy used to heat the atomizer to the vaporization temperature during the user inhalation.

189. The vape device of any of any of claims 185-188, wherein the microcontroller is further programmed to determine the amount of energy used to vaporize the portion of the payload during the user inhalation by adjusting the total amount of energy to account for one or more of the following operating conditions: a starting temperature of the vape device, a starting temperature of the payload, a temperature of ambient air, a relative humidity of ambient air, a pressure of ambient air, an output voltage of the power source, and a temperature ramp rate of the atomizer.

- 90 -

190. The vape device of any of claims 185-189, wherein the microcontroller is further programmed to determine the amount of energy used to vaporize the portion of the payload during the user inhalation by adjusting the total amount of energy to account for the air flow rate within the air flow chamber during the user inhalation.

191. The vape device of any of claims 157-90, further comprising at least one sampling hot wire anemometer located within the air flow chamber between the atomizer and the outlet, wherein the sampling hot wire anemometer is incorporated into a circuit configured to determine a number of droplets of the vaporized payload passing by the sampling hot wire anemometer during each respective user inhalation, and wherein the microcontroller is programmed to determine the dose of the vaporized payload for the user inhalation based further on the number of droplets of the vaporized payload.

192. The vape device of claim 191, further comprising a reference hot wire anemometer located within the air flow chamber between the inlet and the atomizer, wherein the reference hot wire anemometer is incorporated into a circuit configured to determine an air flow rate within the air flow chamber during the user inhalation, and wherein the microcontroller is programmed to determine the dose of the vaporized payload for each respective user inhalation based further on the air flow rate.

193. The vape device of any of claims 191-192, further comprising:

a first temperature sensor located within the air flow chamber between the inlet and the atomizer, wherein the first temperature sensor is incorporated into a first temperature measurement circuit configured to obtain a first plurality of temperature measurements during the user inhalation;

a second temperature sensor located within the air flow chamber between the atomizer and the outlet, wherein the second temperature sensor is incorporated into a second temperature measurement circuit configured to obtain a second plurality of temperature measurements during the user inhalation; and

wherein the microcontroller is programmed to determine the dose of the vaporized payload for each respective user inhalation based further on the first and second plurality of temperature measurements.

- 91 -

194. The vape device of claim 193, wherein each of the first and second temperature sensors comprises one of a thermistor, a thermocouple, an infrared sensor, a bandgap temperature sensor, an analog temperature sensor, or a digital temperature sensor.

195. The vape device of any of claims 191-194, wherein the payload comprises a first component having a first boiling point and a second component having a second boiling point, wherein the first boiling point is lower than the second boiling point, and wherein:

the at least one sampling hot wire anemometer comprises a first sampling hot wire anemometer and a second sampling hot wire anemometer each of which is located within the air flow chamber between the atomizer and the outlet;

the first sampling hot wire anemometer is incorporated into a first circuit configured to (a) operate the first sampling hot wire anemometer at a first temperature that is higher than the first boiling point and lower than the second boiling point and (b) determine a number of droplets of the first component passing by the first sampling hot wire anemometer, during each of a plurality of the user inhalations;

the second sampling hot wire anemometer is incorporated into a second circuit configured to (a) operate the second sampling hot wire anemometer at a second temperature that is higher than both of the first and second boiling points and (b) determine a number of droplets of the second component passing by the second sampling hot wire anemometer, during each of the plurality of the user inhalations; and

the microcontroller is programmed to determine a dose of each of the first and second components for each respective user inhalation based on the number of droplets of each of the first and second components, respectively.

196. The vape device of claim 195, wherein the operation of the first and second hot wire anemometers is reversed during each of a second plurality of the user inhalations such that:

the first circuit is configured to (a) operate the first sampling hot wire anemometer at the second temperature and (b) determine the number of droplets of the second component passing by the first sampling hot wire anemometer; during each of the second plurality of the user inhalations; and

the second circuit is configured to (a) operate the second sampling hot wire anemometer at the first temperature and (b) determine the number of droplets of the first component passing by the second sampling hot wire anemometer, during each of the second plurality of the user inhalations.

- 92 -

197. The vape device of claim 195, wherein the first circuit is configured to determine a droplet size of each of the droplets of the first component passing by the first sampling hot wire anemometer, wherein the second circuit is configured to determine a droplet size of each of the droplets of the second component passing by the second sampling hot wire anemometer, and wherein the microcontroller is programmed to determine the dose of each of the first and second components for each respective user inhalation based further on the droplet size of each of the droplets of the first and second components, respectively.

198. The vape device of any of claims 191-197, wherein each of the hot wire anemometers comprises a wire filament made of one of tungsten, platinum, or platinum-iridium.

199. The vape device of any of claims 157-198, further comprising a wireless transceiver configured to transmit the dose of the vaporized payload to an external computing device.

200. The vape device of any of claims 157-199, wherein transmission of the power signal to the atomizer is disabled when the dose of the vaporized payload reaches a specified dose.

201. The vape device of any of claims 157-200, wherein the microcontroller is programmed to determine a remaining amount of the payload in the payload reservoir based on (a) the total amount of the payload and (b) an aggregated amount of the payload that has been vaporized during the previous user inhalations.

202. The vape device of claim 201, wherein the microcontroller is programmed to determine a portion of the remaining amount of the payload in the payload reservoir that is useable for vaporization.

203. The vape device of any of claims 201-202, wherein the microcontroller is programmed to provide a notice when the remaining amount of the payload in the payload reservoir is below a minimum level.

204. A method for determining a dose of a payload delivered to a user of a vape device during each of a plurality of user inhalations, comprising:

holding a payload to be vaporized;

vaporizing a portion of the payload with an atomizer located between an inlet and an outlet of an air flow chamber to thereby generate a vaporized payload during each respective user inhalation; and

determining a dose of the vaporized payload for each respective user inhalation based on a plurality of light intensity measurements obtained during the user inhalation, wherein the light intensity measurements are associated with light that is transmitted through the vaporized payload, reflected off the vaporized payload, or transmitted through a light transmitting medium positioned within the vaporized payload, when the vaporized payload passes through the air flow chamber.

205. The method of claim 204, further comprising filtering the light reflected off the vaporized payload so as to only pass a range of light wavelengths associated with the vaporized payload.

206. The method of any of claims 204-205, further comprising applying an electric field to the air flow chamber so as to orient a plurality of molecules in the vaporized payload when the vaporized payload passes through the air flow chamber.

207. The method of any of claims 204-206, wherein the step of determining the dose of the vaporized payload for the user inhalation is based further on: (a) a plurality of temperature measurements obtained within the air flow chamber during the user inhalation; and (b) an air flow rate within the air flow chamber during the user inhalation.

208. The method of claim 207, further comprising:

obtaining a first plurality of temperature measurements within the air flow chamber between the inlet and the atomizer during the user inhalation;

obtaining a second plurality of temperature measurements within the air flow chamber between the atomizer and the outlet during the user inhalation; and

wherein the plurality of temperature measurements comprise the first and second plurality of temperature measurements.

209. The method of any of claims 207-208, wherein the step of determining the dose of the vaporized payload for the user inhalation is based further on an air moisture content and an atmospheric pressure within the air flow chamber between the inlet and the atomizer.

210. The method of claim 207-209, wherein the air flow chamber defines an orifice having a cross-sectional area, and wherein the step of determining the air flow rate within the air flow chamber during the user inhalation is based on: (a) a pressure difference across the orifice during the user inhalation; and (b) the cross-sectional area of the orifice.

- 94 -

211. The method of claim 210, wherein the pressure difference across the orifice during the user inhalation is based on:

obtaining a first plurality of pressure measurements on a first side of the orifice during the user inhalation;

obtaining a second plurality of pressure measurements on a second opposing side of the orifice during the user inhalation; and

determining the pressure difference across the orifice during the user inhalation based on the first and second plurality of pressure measurements.

212. The method of claim 210, wherein the pressure difference across the orifice during the user inhalation is based on:

obtaining a plurality of pressure measurements on a side of the orifice before and during the user inhalation; and

determining the pressure difference across the orifice during the user inhalation based on the plurality of pressure measurements.

213. The method of claim 210, wherein the pressure difference across the orifice during the user inhalation is based on:

obtaining a plurality of pressure measurements on a side of the orifice during and after the user inhalation; and

determining the pressure difference across the orifice during the user inhalation based on the plurality of pressure measurements.

214. The method of claim 210, wherein the pressure difference across the orifice during the user inhalation is based on:

obtaining a plurality of pressure measurements on a side of the orifice before, during, and after the user inhalation; and

determining the pressure difference across the orifice during the user inhalation based on the plurality of pressure measurements.

215. The method of any of claims 204-214, wherein the step of determining the dose of the vaporized payload for the user inhalation is based further on: (a) determining an amount of energy used to vaporize the portion of the payload during the user inhalation; and (b) determining a partial mass of the payload that is vaporized during the user inhalation based on the amount of energy used to vaporize the portion of the payload during the user inhalation.

- 95 -

216. The method of claim 215, wherein the payload comprises a fluid payload or a dry material payload containing at least one of nicotine, cannabis, cannabinoid, propylene glycol, polyethylene glycol, or vegetable glycerin.

217. The method of any of claims 215-216, further comprising: (a) identifying one or more components within the payload; (b) identifying a relative percentage and a boiling point for each of the components within the payload; and (c) determining a mass of each of the components within the portion of the payload that is vaporized during the user inhalation.

218. The method of claim 217, further comprising determining an optimal vaporization temperature for the payload based on the relative percentage and the boiling point for each of the components within the payload.

219. The method of any of claims 215-218, further comprising transmitting a power signal from a power source to the atomizer during each user inhalation.

220. The method of claim 219, wherein the step of determining the amount of energy used to vaporize the portion of the payload during the user inhalation comprises: (a) determining an amount of power provided to the atomizer during the user inhalation; (b) determining a duration of the user inhalation; and (c) determining a total amount of energy based on the amount of power provided to the atomizer during the user inhalation and the duration of the user inhalation.

221. The method of claim 220, wherein the step of determining the amount of power provided to the atomizer during the user inhalation is based on: (a) a measurement of an output voltage of the power source during the user inhalation; and (b) a measurement of a current delivered to the atomizer during the user inhalation.

222. The method of claim 220, wherein the step of determining the amount of power provided to the atomizer during the user inhalation is based on: (a) a measurement of a resistance of a path between the power source and the atomizer during the user inhalation; and (b) a measurement of an output voltage of the power source or a current delivered to the atomizer during the user inhalation.

223. The method of any of claims 220-222, wherein the step of determining the amount of energy used to vaporize the portion of the payload during the user inhalation further comprises: (a) determining an amount of energy used to heat the atomizer to a vaporization temperature

during the user inhalation; and (b) adjusting the total amount of energy by subtracting the amount of energy used to heat the atomizer to the vaporization temperature during the user inhalation.

224. The method of any of claims 220-223, wherein the step of determining the amount of energy used to vaporize the portion of the payload during the user inhalation further comprises adjusting the total amount of energy to account for one or more of the following operating conditions: a starting temperature of the vape device, a starting temperature of the payload, a temperature of ambient air, a relative humidity of ambient air, a pressure of ambient air, an output voltage of the power source, and a temperature ramp rate of the atomizer.

225. The method of any of claims 220-224, wherein the step of determining the amount of energy used to vaporize the portion of the payload during the user inhalation further comprises adjusting the total amount of energy to account for the air flow rate within the air flow chamber during the user inhalation.

226. The method of any of claims 204-225, further comprising:

determining a number of droplets of the vaporized payload passing by at least one sampling hot wire anemometer located within the air flow chamber between the atomizer and the outlet during each respective user inhalation; and

wherein the step of determining the dose of the vaporized payload for the user inhalation is based further on the number of droplets of the vaporized payload.

227. The method of claim 226, further comprising determining an air flow rate within the air flow chamber during the user inhalation using a reference hot wire anemometer located within the air flow chamber between the inlet and the atomizer, and wherein the step of determining the dose of the vaporized payload for each respective user inhalation is based further on the air flow rate.

228. The method of any of claims 226-227, further comprising:

obtaining a first plurality of temperature measurements within the air flow chamber between the inlet and the atomizer during the user inhalation;

obtaining a second plurality of temperature measurements within the air flow chamber between the atomizer and the outlet during the user inhalation; and

wherein the step of determining the dose of the vaporized payload for each respective user inhalation is based further on the first and second plurality of temperature measurements.

- 97 -

229. The method of any of claims 226-228, wherein the payload comprises a first component having a first boiling point and a second component having a second boiling point, wherein the first boiling point is lower than the second boiling point, wherein the at least one sampling hot wire anemometer comprises a first sampling hot wire anemometer and a second sampling hot wire anemometer each of which is located within the air flow chamber between the atomizer and the outlet, and wherein the method further comprises performing the following steps during each of a plurality of the user inhalations:

- operating the first sampling hot wire anemometer at a first temperature that is higher than the first boiling point and lower than the second boiling point;

- determining a number of droplets of the first component passing by the first sampling hot wire anemometer;

- operating the second sampling hot wire anemometer at a second temperature that is higher than both of the first and second boiling points;

- determining a number of droplets of the second component passing by the second sampling hot wire anemometer; and

- wherein the step of determining the dose of the vaporized payload comprises determining a dose of each of the first and second components based on the number of droplets of each of the first and second components, respectively.

230. The method of claim 229, wherein the operation of the first and second hot wire anemometers is reversed during each of a second plurality of the user inhalations to comprise the steps of:

- operating the first sampling hot wire anemometer at the second temperature;

- determining the number of droplets of the second component passing by the first sampling hot wire anemometer;

- operating the second sampling hot wire anemometer at the first temperature; and

- determining the number of droplets of the first component passing by the second sampling hot wire anemometer.

231. The method of claim 229, further comprising:

- determining a droplet size of each of the droplets of the first component passing by the first sampling hot wire anemometer;

- determining a droplet size of each of the droplets of the second component passing by the second sampling hot wire anemometer; and

- 98 -

wherein the step of determining the dose of each of the first and second components is based further on the droplet size of each of the droplets of the first and second components, respectively.

232. The method of any of claims 204-231, further comprising transmitting the dose of the vaporized payload to an external computing device.

233. The method of any of claims 204-232, further comprising disabling transmission of the power signal to the atomizer when the dose of the vaporized payload reaches a specified dose.

234. The method of any of claims 204-233, further comprising determining a remaining amount of the payload in the payload reservoir based on (a) the total amount of the payload and (b) an aggregated amount of the payload that has been vaporized during the previous user inhalations.

235. The method of claim 234, further comprising determining a portion of the remaining amount of the payload in the payload reservoir that is useable for vaporization.

236. The method of any of claims 234-235, further comprising providing a notice when the remaining amount of the payload in the payload reservoir is below a minimum level.

237. A vape device for determining a dose of a payload delivered to a user during each of a plurality of user inhalations, comprising:

a payload reservoir configured to contain a payload to be vaporized;

an air flow chamber that extends between an inlet and an outlet;

an atomizer located between the inlet and the outlet of the air flow chamber, wherein the atomizer is configured to vaporize a portion of the payload to thereby generate a vaporized payload during each respective user inhalation;

at least one sampling hot wire anemometer located within the air flow chamber between the atomizer and the outlet, wherein the sampling hot wire anemometer is incorporated into a circuit configured to determine a number of droplets of the vaporized payload passing by the sampling hot wire anemometer during each respective user inhalation; and

a microcontroller programmed to determine a dose of the vaporized payload for each respective user inhalation based on the number of droplets of the vaporized payload.

238. The vape device of claim 237, further comprising a reference hot wire anemometer located within the air flow chamber between the inlet and the atomizer, wherein the reference

hot wire anemometer is incorporated into a circuit configured to determine an air flow rate within the air flow chamber during the user inhalation, and wherein the microcontroller is programmed to determine the dose of the vaporized payload for each respective user inhalation based further on the air flow rate.

239. The vape device of any of claims 237-238, further comprising:

a first temperature sensor located within the air flow chamber between the inlet and the atomizer, wherein the first temperature sensor is incorporated into a first temperature measurement circuit configured to obtain a first plurality of temperature measurements during the user inhalation;

a second temperature sensor located within the air flow chamber between the atomizer and the outlet, wherein the second temperature sensor is incorporated into a second temperature measurement circuit configured to obtain a second plurality of temperature measurements during the user inhalation; and

wherein the microcontroller is programmed to determine the dose of the vaporized payload for each respective user inhalation based further on the first and second plurality of temperature measurements.

240. The vape device of claim 239, wherein each of the first and second temperature sensors comprises one of a thermistor, a thermocouple, an infrared sensor, a bandgap temperature sensor, an analog temperature sensor, or a digital temperature sensor.

241. The vape device of any of claims 237-240, wherein the payload comprises a first component having a first boiling point and a second component having a second boiling point, wherein the first boiling point is lower than the second boiling point, and wherein:

the at least one sampling hot wire anemometer comprises a first sampling hot wire anemometer and a second sampling hot wire anemometer each of which is located within the air flow chamber between the atomizer and the outlet;

the first sampling hot wire anemometer is incorporated into a first circuit configured to (a) operate the first sampling hot wire anemometer at a first temperature that is higher than the first boiling point and lower than the second boiling point and (b) determine a number of droplets of the first component passing by the first sampling hot wire anemometer, during each of a plurality of the user inhalations;

the second sampling hot wire anemometer is incorporated into a second circuit configured to (a) operate the second sampling hot wire anemometer at a second temperature

- 100 -

that is higher than both of the first and second boiling points and (b) determine a number of droplets of the second component passing by the second sampling hot wire anemometer, during each of the plurality of the user inhalations; and

the microcontroller is programmed to determine a dose of each of the first and second components for each respective user inhalation based on the number of droplets of each of the first and second components, respectively.

242. The vape device of claim 241, wherein the operation of the first and second hot wire anemometers is reversed during each of a second plurality of the user inhalations such that:

the first circuit is configured to (a) operate the first sampling hot wire anemometer at the second temperature and (b) determine the number of droplets of the second component passing by the first sampling hot wire anemometer; during each of the second plurality of the user inhalations; and

the second circuit is configured to (a) operate the second sampling hot wire anemometer at the first temperature and (b) determine the number of droplets of the first component passing by the second sampling hot wire anemometer, during each of the second plurality of the user inhalations.

243. The vape device of claim 241, wherein the first circuit is configured to determine a droplet size of each of the droplets of the first component passing by the first sampling hot wire anemometer, wherein the second circuit is configured to determine a droplet size of each of the droplets of the second component passing by the second sampling hot wire anemometer, and wherein the microcontroller is programmed to determine the dose of each of the first and second components for each respective user inhalation based further on the droplet size of each of the droplets of the first and second components, respectively.

244. The vape device of any of claims 237-243, wherein each of the hot wire anemometers comprises a wire filament made of one of tungsten, platinum, or platinum-iridium.

245. The vape device of any of claims 237-244, wherein the microcontroller is programmed to determine the dose of the vaporized payload for each user inhalation based further on: (a) a plurality of temperature measurements obtained within the air flow chamber during the user inhalation; and (b) an air flow rate within the air flow chamber during the user inhalation.

246. The vape device of claim 245, further comprising:

- 101 -

a first temperature sensor located within the air flow chamber between the inlet and the atomizer, wherein the first temperature sensor is incorporated into a first temperature measurement circuit configured to obtain a first plurality of temperature measurements during the user inhalation;

a second temperature sensor located within the air flow chamber between the atomizer and the outlet, wherein the second temperature sensor is incorporated into a second temperature measurement circuit configured to obtain a second plurality of temperature measurements during the user inhalation; and

wherein the plurality of temperature measurements comprise the first and second plurality of temperature measurements.

247. The vape device of claim 246, wherein each of the first and second temperature sensors comprises one of a thermistor, a thermocouple, an infrared sensor, a bandgap temperature sensor, an analog temperature sensor, or a digital temperature sensor.

248. The vape device of any of claims 245-247, wherein the microcontroller is programmed to determine the dose of the vaporized payload for the user inhalation based further on an air moisture content and an atmospheric pressure within the air flow chamber between the inlet and the atomizer.

249. The vape device of any of claims 245-248, wherein the air flow chamber defines an orifice having a cross-sectional area, and wherein the microcontroller is programmed to determine the air flow rate within the air flow chamber during the user inhalation based on: (a) a pressure difference across the orifice during the user inhalation; and (b) the cross-sectional area of the orifice.

250. The vape device of claim 249, further comprising:

a first pressure sensor located on a first side of the orifice, wherein the first pressure sensor is incorporated into a first pressure measurement circuit configured to obtain a first plurality of pressure measurements during the user inhalation;

a second pressure sensor located on a second opposing side of the orifice, wherein the second pressure sensor is incorporated into a second pressure measurement circuit configured to obtain a second plurality of pressure measurements during the user inhalation; and

wherein the pressure difference across the orifice during the user inhalation is based on the first and second plurality of pressure measurements.

- 102 -

251. The vape device of claim 249, further comprising:
a pressure sensor located on a side of the orifice, wherein the pressure sensor is incorporated into a pressure measurement circuit configured to obtain a plurality of pressure measurements before and during the user inhalation; and
wherein the pressure difference across the orifice during the user inhalation is based on the plurality of the pressure measurements.
252. The vape device of claim 249, further comprising:
a pressure sensor located on a side of the orifice, wherein the pressure sensor is incorporated into a pressure measurement circuit configured to obtain a plurality of pressure measurements during and after the user inhalation; and
wherein the pressure difference across the orifice during the user inhalation is based on the plurality of pressure measurements.
253. The vape device of claim 249, further comprising:
a pressure sensor located on a side of the orifice, wherein the pressure sensor is incorporated into a pressure measurement circuit configured to obtain a plurality of pressure measurements before, during, and after the user inhalation; and
wherein the pressure difference across the orifice during the user inhalation is based on the plurality of pressure measurements.
254. The vape device of any of claims 237-253, wherein the microcontroller is programmed to determine the dose of the vaporized payload for the respective user inhalation based further on: (a) determining an amount of energy used to vaporize the portion of the payload during the user inhalation; and (b) determining a partial mass of the payload that is vaporized during the user inhalation based on the amount of energy used to vaporize the portion of the payload during the user inhalation.
255. The vape device of claim 254, wherein the payload comprises a fluid payload or a dry material payload containing at least one of nicotine, cannabis, cannabinoid, propylene glycol, polyethylene glycol, or vegetable glycerin.
256. The vape device of any of claims 254-255, wherein the microcontroller is further programmed to: (a) identify one or more components within the payload; (b) identify a relative percentage and a boiling point for each of the components within the payload; and

- 103 -

(c) determine a mass of each of the components within the portion of the payload that is vaporized during the user inhalation.

257. The vape device of claim 256, wherein the microcontroller is further programmed to determine an optimal vaporization temperature for the payload based on the relative percentage and the boiling point for each of the components within the payload.

258. The vape device of any of claims 254-257, further comprising a power source configured to generate a power signal during each user inhalation.

259. The vape device of any of claims 254-258, further comprising a memory device configured to store information that enables the microcontroller to correlate the amount of energy used to vaporize the portion of the payload during the user inhalation to the partial mass of the payload that is vaporized during the user inhalation.

260. The vape device of any of claims 254-259, wherein the vape device comprises a cartridge releasably connected to a control assembly, and wherein the microcontroller is contained within the control assembly.

261. The vape device of any of claims 254-259, wherein the vape device comprises a cartridge releasably connected to a control assembly, and wherein the microcontroller is contained within the cartridge.

262. The vape device of any of claims 254-261, wherein the power source comprises a battery, and wherein the power signal comprises a direct current or a pulsed direct current.

263. The vape device of any of claims 254-262, wherein the microcontroller is programmed to determine the amount of energy used to vaporize the portion of the payload during the user inhalation based on: (a) determining an amount of power provided to the atomizer during the user inhalation; (b) determining a duration of the user inhalation; and (c) determining a total amount of energy based on the amount of power provided to the atomizer during the user inhalation and the duration of the user inhalation.

264. The vape device of claim 263, wherein the microcontroller is programmed to determine the amount of power provided to the atomizer during the user inhalation based on: (a) a measurement of an output voltage of the power source during the user inhalation; and (b) a measurement of a current delivered to the atomizer during the user inhalation.

- 104 -

265. The vape device of claim 263, wherein the microcontroller is programmed to determine the amount of power provided to the atomizer during the user inhalation based on: (a) a measurement of a resistance of a path between the power source and the atomizer during the user inhalation; and (b) a measurement of an output voltage of the power source or a measurement of a current delivered to the atomizer during the user inhalation.

266. The vape device of any of claims 263-265, wherein the microcontroller is further programmed to determine the amount of energy used to vaporize the portion of the payload during the user inhalation based on: (a) determining an amount of energy used to heat the atomizer to a vaporization temperature during the user inhalation; and (b) adjusting the total amount of energy by subtracting the amount of energy used to heat the atomizer to the vaporization temperature during the user inhalation.

267. The vape device of any of any of claims 263-266, wherein the microcontroller is further programmed to determine the amount of energy used to vaporize the portion of the payload during the user inhalation by adjusting the total amount of energy to account for one or more of the following operating conditions: a starting temperature of the vape device, a starting temperature of the payload, a temperature of ambient air, a relative humidity of ambient air, a pressure of ambient air, an output voltage of the power source, and a temperature ramp rate of the atomizer.

268. The vape device of any of claims 263-267, wherein the microcontroller is further programmed to determine the amount of energy used to vaporize the portion of the payload during the user inhalation by adjusting the total amount of energy to account for the air flow rate within the air flow chamber during the user inhalation.

269. The vape device of any of claims 237-268, further comprising a light source and a light detector that form a transmissive light sensor in which light emitted from the light source is transmitted through the vaporized payload to the light detector, wherein the light source and the light detector are incorporated into a light intensity measurement circuit configured to obtain a plurality of light intensity measurements during the user inhalation, and wherein the microcontroller is programmed to determine the dose of the vaporized payload for the user inhalation based further on the plurality of light intensity measurements.

270. The vape device of any of claims 237-268, further comprising a light source and a light detector that form a reflective light sensor in which light emitted from the light source is

- 105 -

reflected off the vaporized payload to the light detector, wherein the light source and the light detector are incorporated into a light intensity measurement circuit configured to obtain a plurality of light intensity measurements during the user inhalation, and wherein the microcontroller is programmed to determine the dose of the vaporized payload for the user inhalation based further on the plurality of light intensity measurements.

271. The vape device of any of claims 237-268, further comprising a light source and a light detector that form a light sensor in which light emitted from the light source is transmitted through a light transmitting medium positioned within the vaporized payload to the light detector, wherein the light source and the light detector are incorporated into a light intensity measurement circuit configured to obtain a plurality of light intensity measurements during the user inhalation, and wherein the microcontroller is programmed to determine the dose of the vaporized payload for the user inhalation based further on the plurality of light intensity measurements.

272. The vape device of any of claims 269-271, wherein the vape device comprises a cartridge releasably connected to a control assembly, and wherein the light source and the light detector are contained within the cartridge.

273. The vape device of any of claims 269-271, wherein the vape device comprises a cartridge releasably connected to a control assembly, and wherein the light source and the light detector are contained within the control assembly.

274. The vape device of any of claims 269-271, wherein the vape device comprises a cartridge releasably connected to a control assembly, and wherein the light source is contained with the control assembly and the light detector is contained within the cartridge.

275. The vape device of any of claims 269-274, wherein the light detector is configured to filter the light so as to only pass a range of light wavelengths associated with the vaporized payload.

276. The vape device of any of claims 269-275, wherein the microcontroller is programmed to vary one or both of an intensity of the light emitted by the light source and a gain of the light detector.

- 106 -

277. The vape device of any of claims 269-276, wherein the microcontroller is programmed to apply an electric field to the air flow chamber so as to orient a plurality of molecules in the vaporized payload when the vaporized payload passes through the air flow chamber.

278. The vape device of any of claims 237-277, further comprising a wireless transceiver configured to transmit the dose of the vaporized payload to an external computing device.

279. The vape device of any of claims 237-278, wherein transmission of the power signal to the atomizer is disabled when the dose of the vaporized payload reaches a specified dose.

280. The vape device of any of claims 237-279, wherein the microcontroller is programmed to determine a remaining amount of the payload in the payload reservoir based on (a) the total amount of the payload and (b) an aggregated amount of the payload that has been vaporized during the previous user inhalations.

281. The vape device of claim 280, wherein the microcontroller is programmed to determine a portion of the remaining amount of the payload in the payload reservoir that is useable for vaporization.

282. The vape device of any of claims 280-281, wherein the microcontroller is programmed to provide a notice when the remaining amount of the payload in the payload reservoir is below a minimum level.

283. A method for determining a dose of a payload delivered to a user during each of a plurality of user inhalations, comprising:

holding a payload to be vaporized;

vaporizing a portion of the payload with an atomizer positioned between an inlet and an outlet of an air flow chamber to thereby generate a vaporized payload during each respective user inhalation;

determining a number of droplets of the vaporized payload passing by at least one sampling hot wire anemometer located within the air flow chamber between the atomizer and the outlet during each respective user inhalation; and

determining a dose of the vaporized payload for each respective user inhalation based on the number of droplets of the vaporized payload.

284. The method of claim 283, further comprising determining an air flow rate within the air flow chamber during the user inhalation using a reference hot wire anemometer located

- 107 -

within the air flow chamber between the inlet and the atomizer, and wherein the step of determining the dose of the vaporized payload for each respective user inhalation is based further on the air flow rate.

285. The method of any of claims 283-284, further comprising:

obtaining a first plurality of temperature measurements within the air flow chamber between the inlet and the atomizer during the user inhalation;

obtaining a second plurality of temperature measurements within the air flow chamber between the atomizer and the outlet during the user inhalation; and

wherein the step of determining the dose of the vaporized payload for each respective user inhalation is based further on the first and second plurality of temperature measurements.

286. The method of any of claims 283-285, wherein the payload comprises a first component having a first boiling point and a second component having a second boiling point, wherein the first boiling point is lower than the second boiling point, wherein the at least one sampling hot wire anemometer comprises a first sampling hot wire anemometer and a second sampling hot wire anemometer each of which is located within the air flow chamber between the atomizer and the outlet, and wherein the method further comprises performing the following steps during each of a plurality of the user inhalations:

operating the first sampling hot wire anemometer at a first temperature that is higher than the first boiling point and lower than the second boiling point;

determining a number of droplets of the first component passing by the first sampling hot wire anemometer;

operating the second sampling hot wire anemometer at a second temperature that is higher than both of the first and second boiling points;

determining a number of droplets of the second component passing by the second sampling hot wire anemometer; and

wherein the step of determining the dose of the vaporized payload comprises determining a dose of each of the first and second components based on the number of droplets of each of the first and second components, respectively.

287. The method of claim 286, wherein the operation of the first and second hot wire anemometers is reversed during each of a second plurality of the user inhalations to comprise the steps of:

operating the first sampling hot wire anemometer at the second temperature;

- 108 -

determining the number of droplets of the second component passing by the first sampling hot wire anemometer;

operating the second sampling hot wire anemometer at the first temperature; and

determining the number of droplets of the first component passing by the second sampling hot wire anemometer.

288. The method of claim 286, further comprising:

determining a droplet size of each of the droplets of the first component passing by the first sampling hot wire anemometer;

determining a droplet size of each of the droplets of the second component passing by the second sampling hot wire anemometer; and

wherein the step of determining the dose of each of the first and second components is based further on the droplet size of each of the droplets of the first and second components, respectively.

289. The method of any of claims 283-288, wherein the step of determining the dose of the vaporized payload for the user inhalation is based further on: (a) a plurality of temperature measurements obtained within the air flow chamber during the user inhalation; and (b) an air flow rate within the air flow chamber during the user inhalation.

290. The method of claim 289, further comprising:

obtaining a first plurality of temperature measurements within the air flow chamber between the inlet and the atomizer during the user inhalation;

obtaining a second plurality of temperature measurements within the air flow chamber between the atomizer and the outlet during the user inhalation; and

wherein the plurality of temperature measurements comprise the first and second plurality of temperature measurements.

291. The method of any of claims 289-290, wherein the step of determining the dose of the vaporized payload for the user inhalation is based further on an air moisture content and an atmospheric pressure within the air flow chamber between the inlet and the atomizer.

292. The method of claim 289-291, wherein the air flow chamber defines an orifice having a cross-sectional area, and wherein the step of determining the air flow rate within the air flow chamber during the user inhalation is based on: (a) a pressure difference across the orifice during the user inhalation; and (b) the cross-sectional area of the orifice.

293. The method of claim 292, wherein the pressure difference across the orifice during the user inhalation is based on:

obtaining a first plurality of pressure measurements on a first side of the orifice during the user inhalation;

obtaining a second plurality of pressure measurements on a second opposing side of the orifice during the user inhalation; and

determining the pressure difference across the orifice during the user inhalation based on the first and second plurality of pressure measurements.

294. The method of claim 292, wherein the pressure difference across the orifice during the user inhalation is based on:

obtaining a plurality of pressure measurements on a side of the orifice before and during the user inhalation; and

determining the pressure difference across the orifice during the user inhalation based on the plurality of pressure measurements.

295. The method of claim 292, wherein the pressure difference across the orifice during the user inhalation is based on:

obtaining a plurality of pressure measurements on a side of the orifice during and after the user inhalation; and

determining the pressure difference across the orifice during the user inhalation based on the plurality of pressure measurements.

296. The method of claim 292, wherein the pressure difference across the orifice during the user inhalation is based on:

obtaining a plurality of pressure measurements on a side of the orifice before, during, and after the user inhalation; and

determining the pressure difference across the orifice during the user inhalation based on the plurality of pressure measurements.

297. The method of any of claims 283-296, wherein the step of determining the dose of the vaporized payload for the user inhalation is based further on: (a) determining an amount of energy used to vaporize the portion of the payload during the user inhalation; and (b) determining a partial mass of the payload that is vaporized during the user inhalation based on the amount of energy used to vaporize the portion of the payload during the user inhalation.

- 110 -

298. The method of claim 297, wherein the payload comprises a fluid payload or a dry material payload containing at least one of nicotine, cannabis, cannabinoid, propylene glycol, polyethylene glycol, or vegetable glycerin.

299. The method of any of claims 297-298, further comprising: (a) identifying one or more components within the payload; (b) identifying a relative percentage and a boiling point for each of the components within the payload; and (c) determining a mass of each of the components within the portion of the payload that is vaporized during the user inhalation.

300. The method of claim 299, further comprising determining an optimal vaporization temperature for the payload based on the relative percentage and the boiling point for each of the components within the payload.

301. The method of any of claims 297-300, further comprising transmitting a power signal from a power source to the atomizer during each user inhalation.

302. The method of claim 301, wherein the step of determining the amount of energy used to vaporize the portion of the payload during the user inhalation comprises: (a) determining an amount of power provided to the atomizer during the user inhalation; (b) determining a duration of the user inhalation; and (c) determining a total amount of energy based on the amount of power provided to the atomizer during the user inhalation and the duration of the user inhalation.

303. The method of claim 302, wherein the step of determining the amount of power provided to the atomizer during the user inhalation is based on: (a) a measurement of an output voltage of the power source during the user inhalation; and (b) a measurement of a current delivered to the atomizer during the user inhalation.

304. The method of claim 302, wherein the step of determining the amount of power provided to the atomizer during the user inhalation is based on: (a) a measurement of a resistance of a path between the power source and the atomizer during the user inhalation; and (b) a measurement of an output voltage of the power source or a current delivered to the atomizer during the user inhalation.

305. The method of any of claims 301-304, wherein the step of determining the amount of energy used to vaporize the portion of the payload during the user inhalation further comprises: (a) determining an amount of energy used to heat the atomizer to a vaporization temperature

- 111 -

during the user inhalation; and (b) adjusting the total amount of energy by subtracting the amount of energy used to heat the atomizer to the vaporization temperature during the user inhalation.

306. The method of any of claims 301-305, wherein the step of determining the amount of energy used to vaporize the portion of the payload during the user inhalation further comprises adjusting the total amount of energy to account for one or more of the following operating conditions: a starting temperature of the vape device, a starting temperature of the payload, a temperature of ambient air, a relative humidity of ambient air, a pressure of ambient air, an output voltage of the power source, and a temperature ramp rate of the atomizer.

307. The method of any of claims 301-306, wherein the step of determining the amount of energy used to vaporize the portion of the payload during the user inhalation further comprises adjusting the total amount of energy to account for the air flow rate within the air flow chamber during the user inhalation.

308. The method of any of claims 283-307, further comprising:

obtaining a plurality of light intensity measurements during the user inhalation, wherein the light intensity measurements are associated with light that is transmitted through the vaporized payload, reflected off the vaporized payload, or transmitted through a light transmitting medium positioned within the vaporized payload, when the vaporized payload passes through the air flow chamber; and

wherein the step of determining the dose of the vaporized payload for the user inhalation is based further on the plurality of light intensity measurements.

309. The method of claim 308, further comprising filtering the light reflected off the vaporized payload so as to only pass a range of light wavelengths associated with the vaporized payload.

310. The method of any of claims 308-309, further comprising applying an electric field to the air flow chamber so as to orient a plurality of molecules in the vaporized payload when the vaporized payload passes through the air flow chamber.

311. The method of any of claims 283-310, further comprising transmitting the dose of the vaporized payload to an external computing device.

- 112 -

312. The method of any of claims 283-311, further comprising disabling transmission of the power signal to the atomizer when the dose of the vaporized payload reaches a specified dose.

313. The method of any of claims 283-312, further comprising determining a remaining amount of the payload in the payload reservoir based on (a) the total amount of the payload and (b) an aggregated amount of the payload that has been vaporized during the previous user inhalations.

314. The method of claim 313, further comprising determining a portion of the remaining amount of the payload in the payload reservoir that is useable for vaporization.

315. The method of any of claims 313-314, further comprising providing a notice when the remaining amount of the payload in the payload reservoir is below a minimum level.

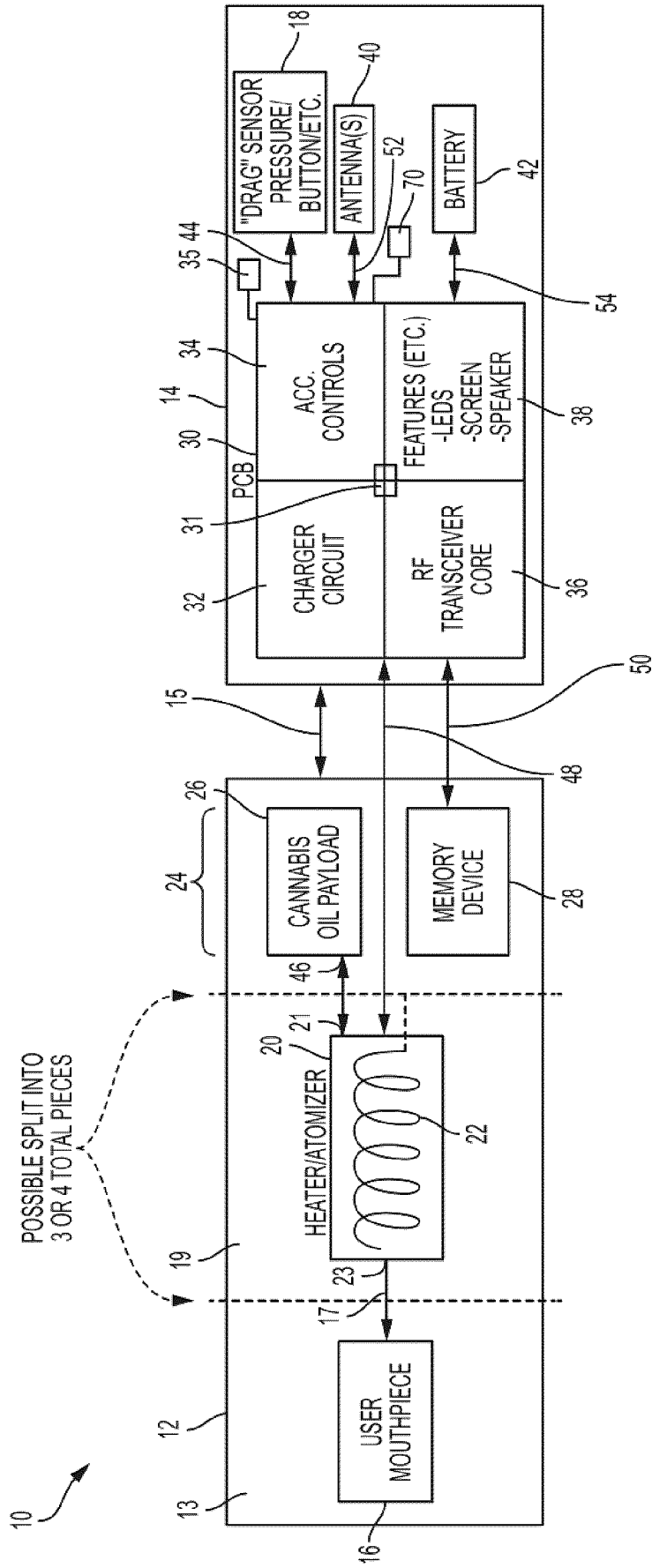

FIG. 1

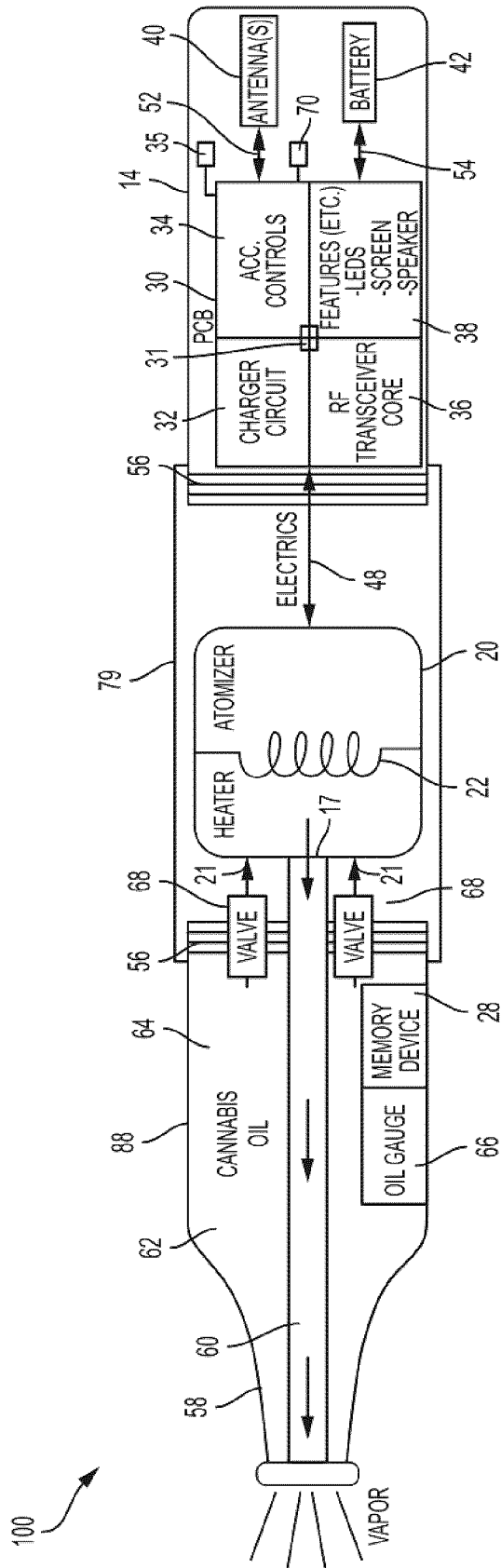

FIG. 2

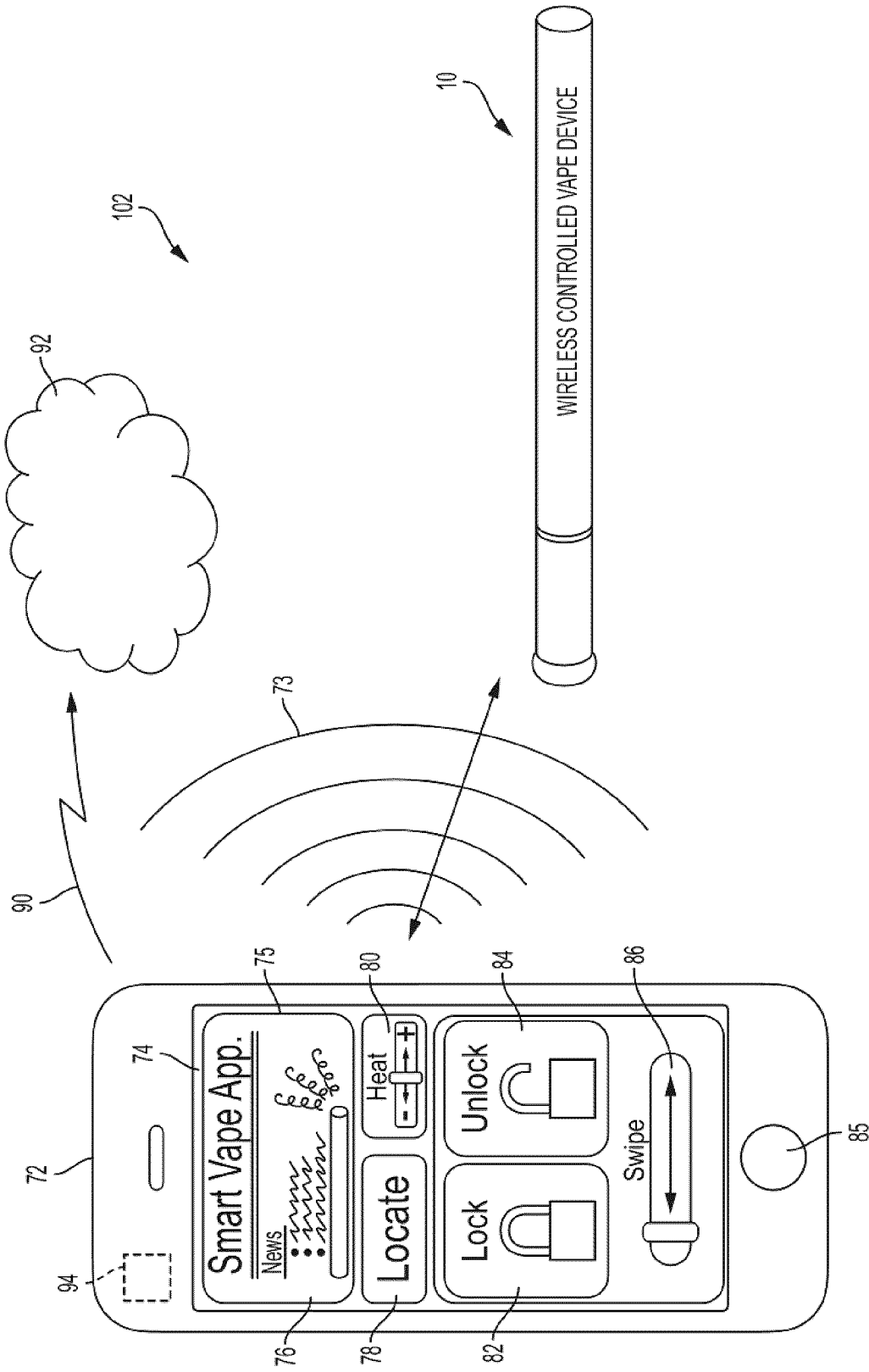

FIG. 3

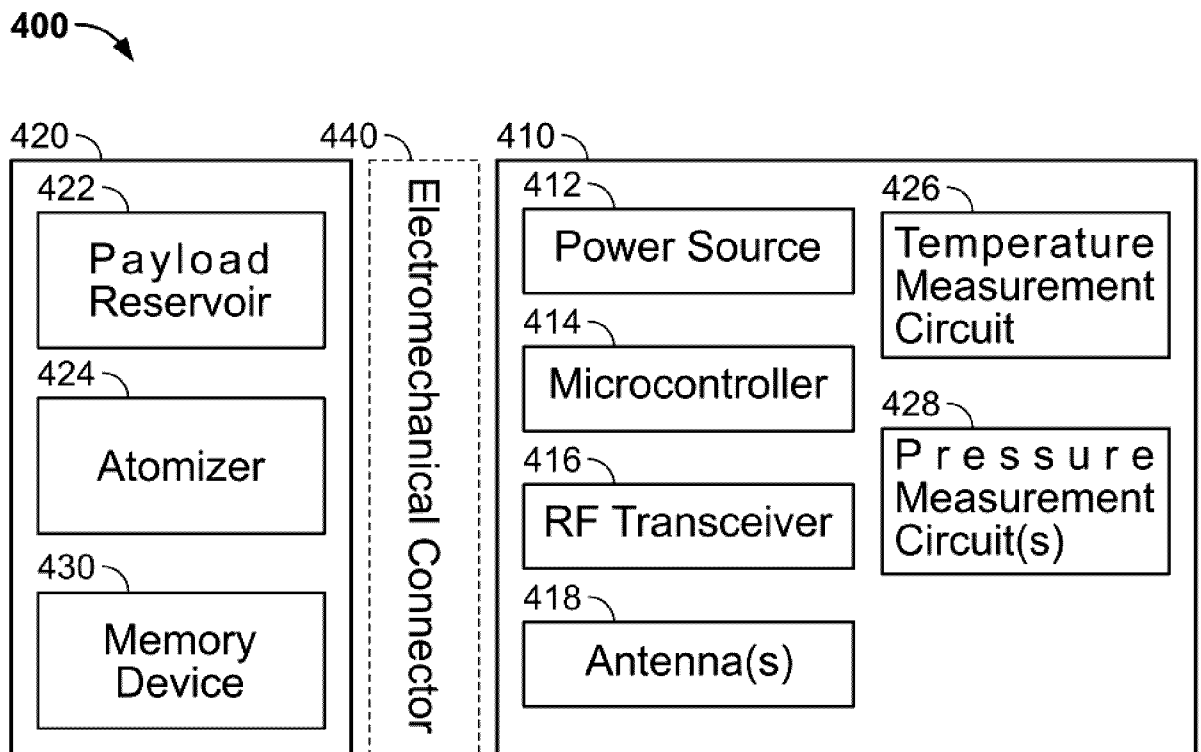

FIG. 4

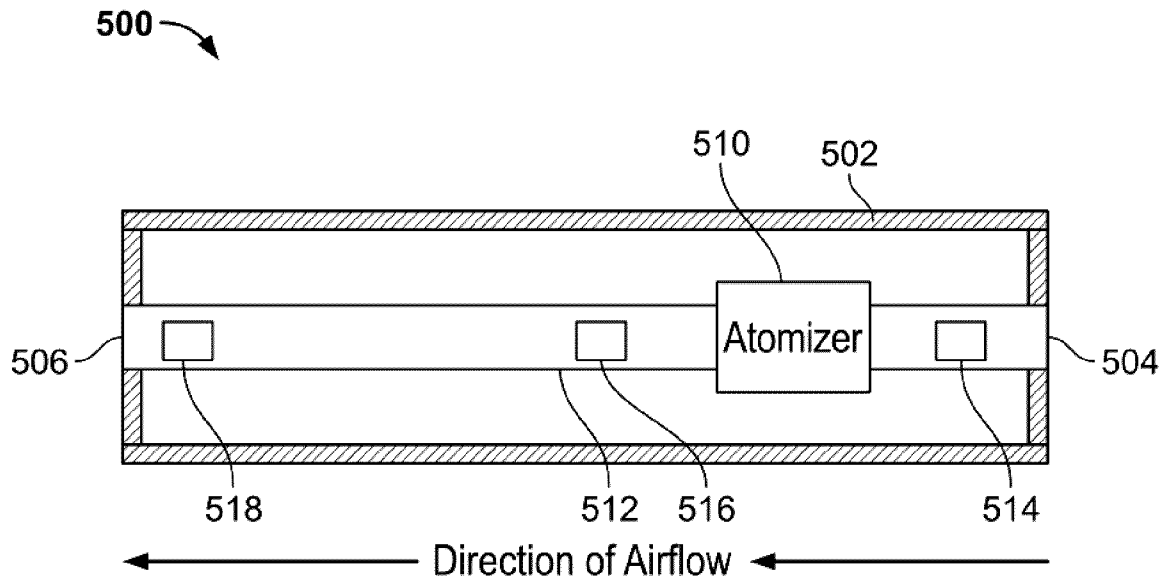

FIG. 5

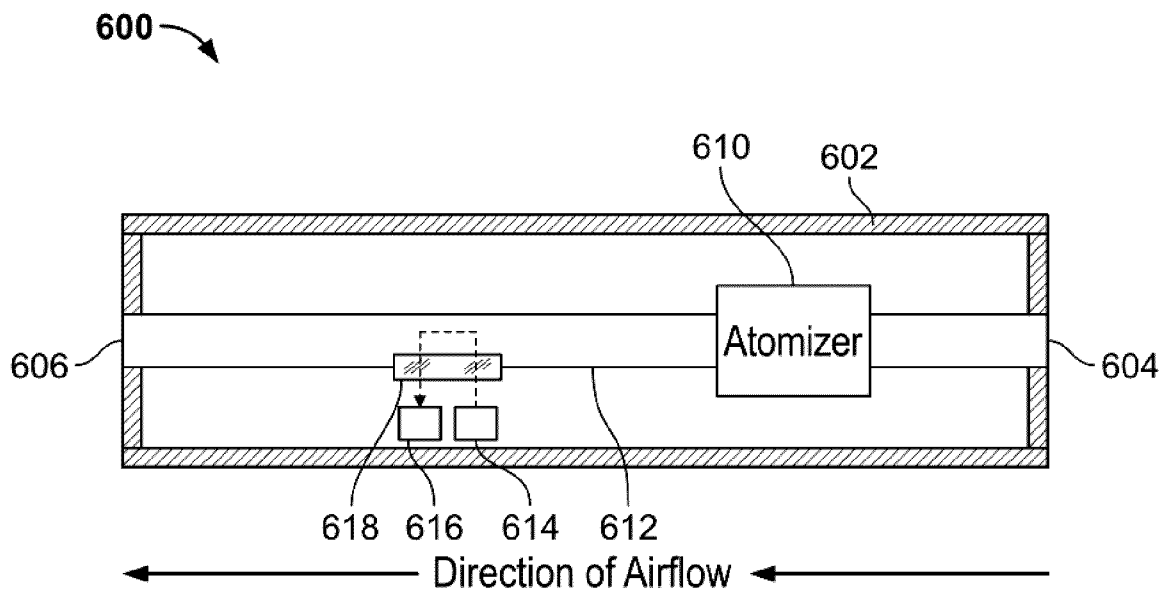

FIG. 6

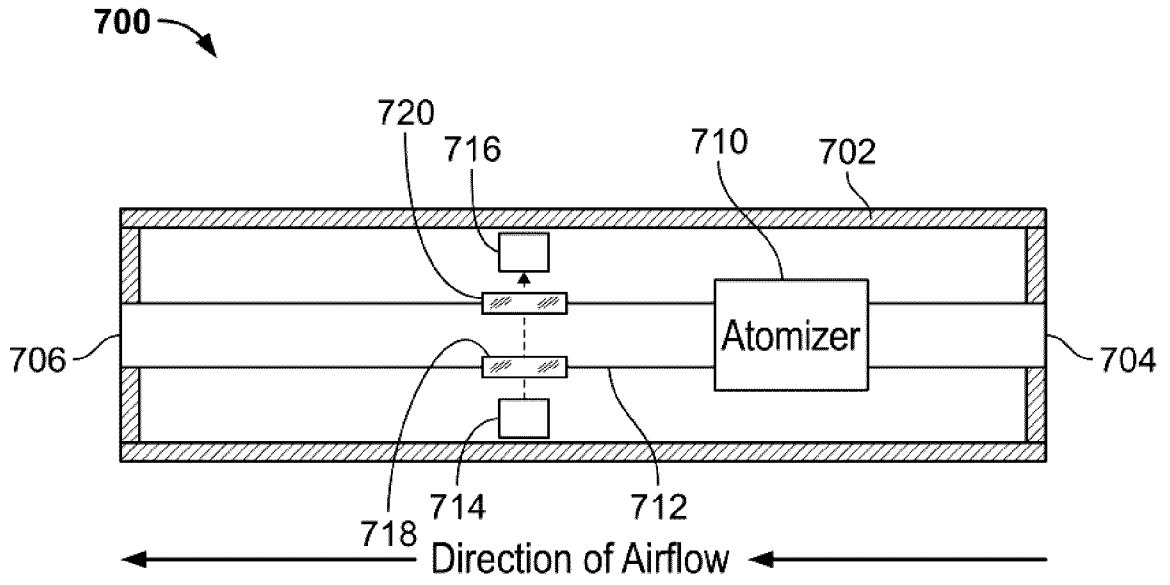

FIG. 7

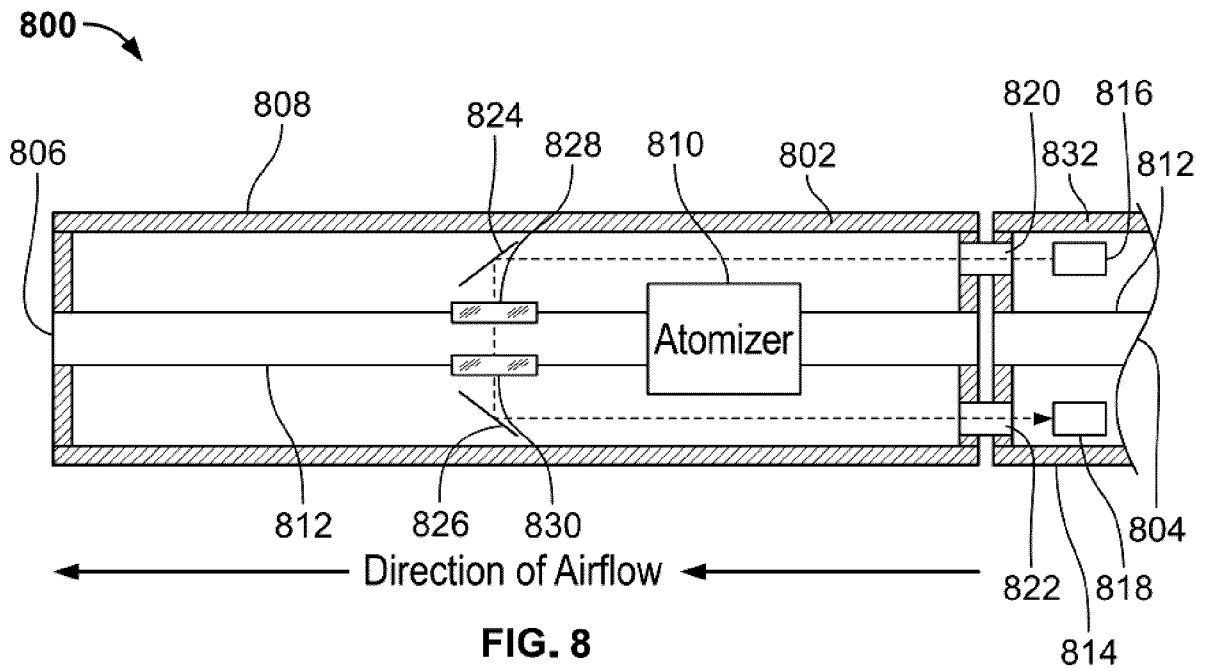

FIG. 8

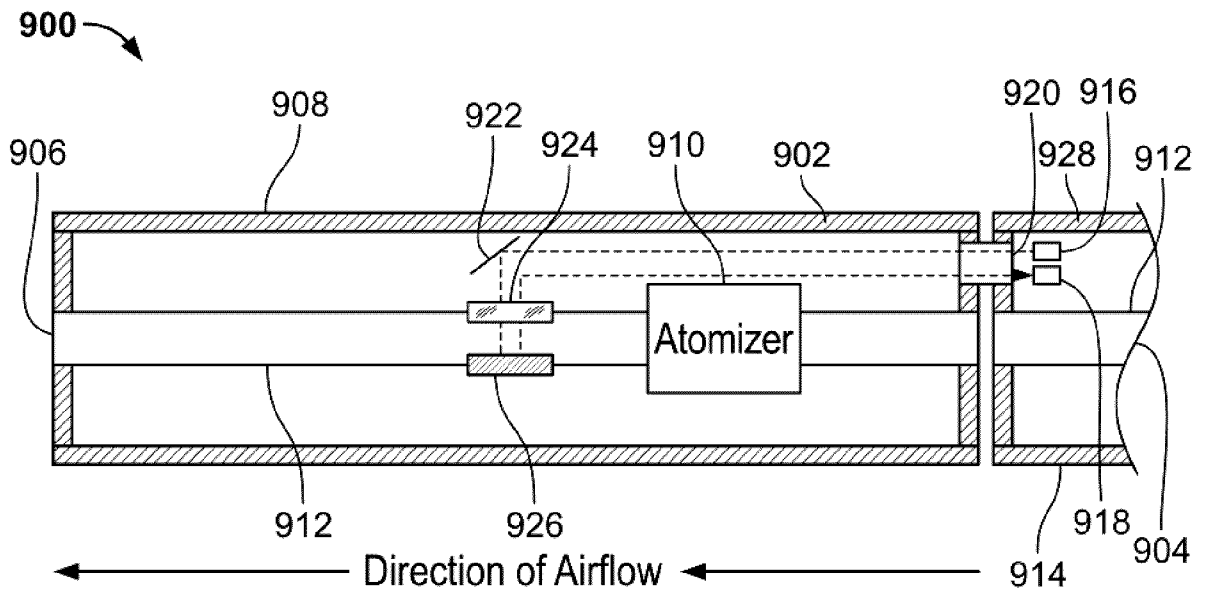

FIG. 9

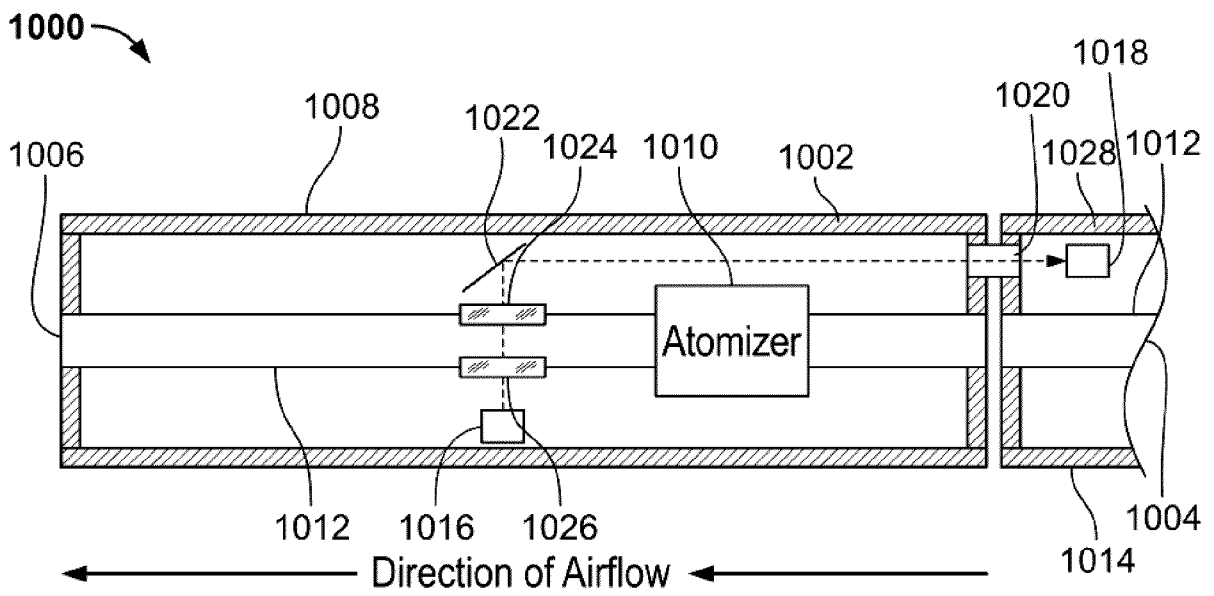

FIG. 10

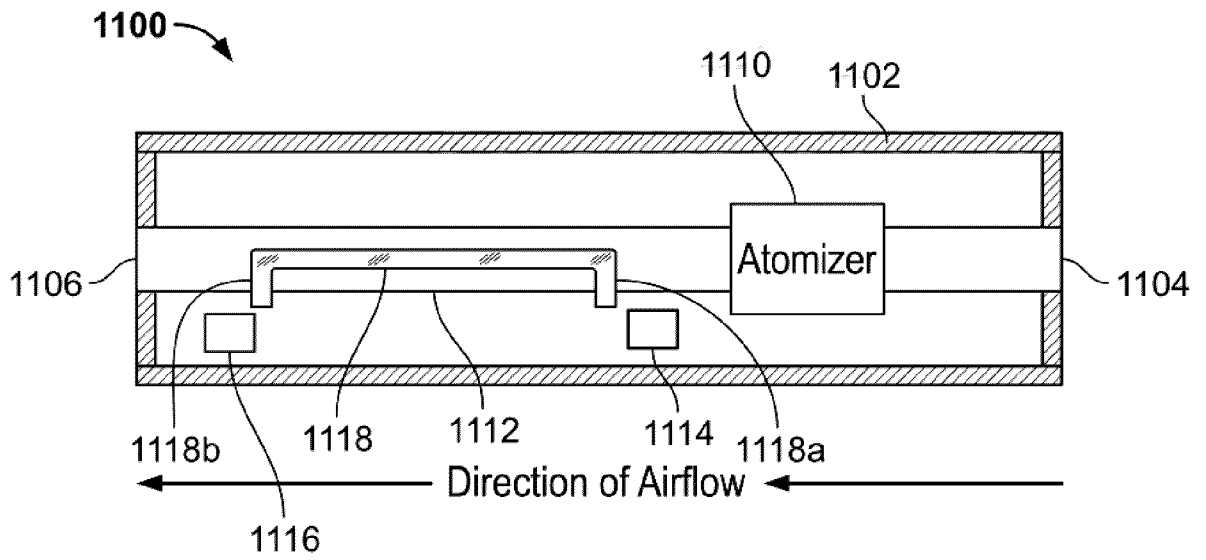

FIG. 11A

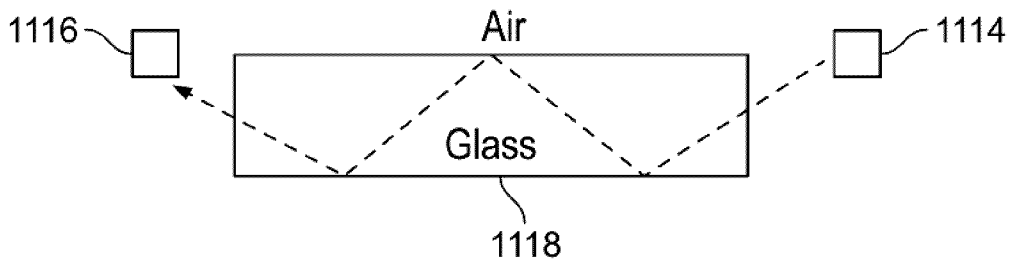

FIG. 11B

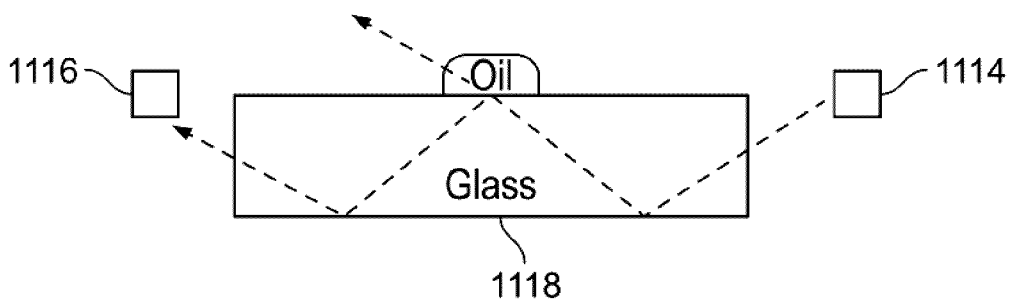

FIG. 11C

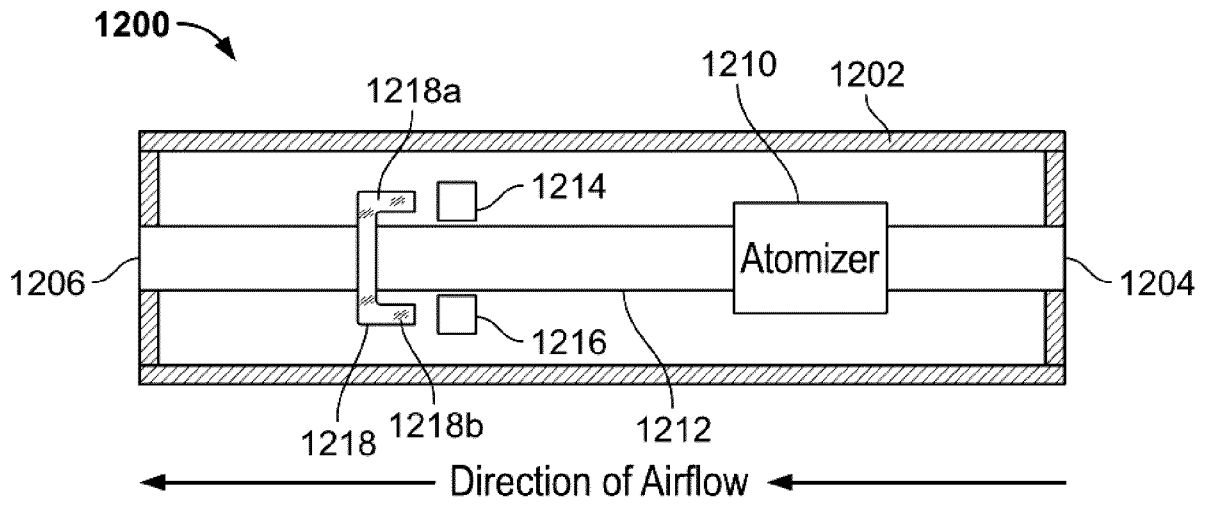

FIG. 12

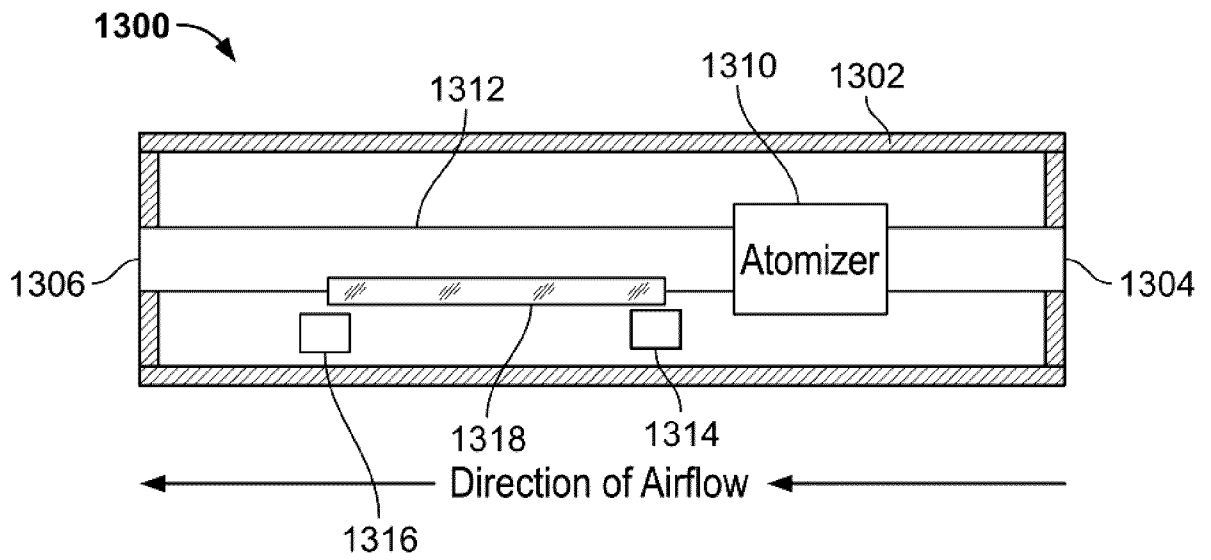

FIG. 13

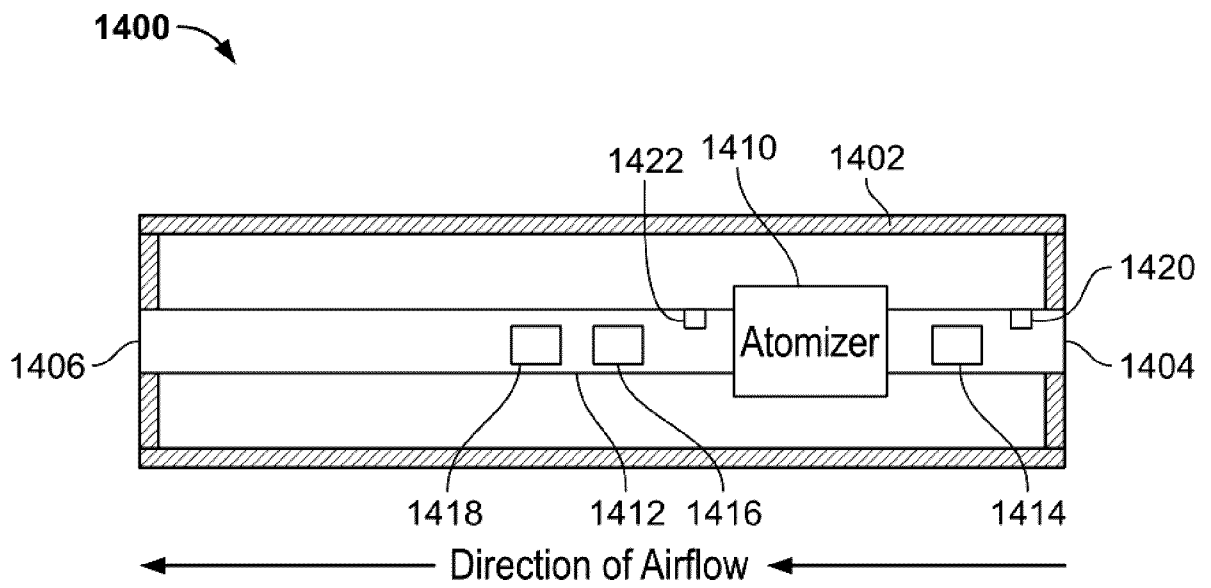

FIG. 14

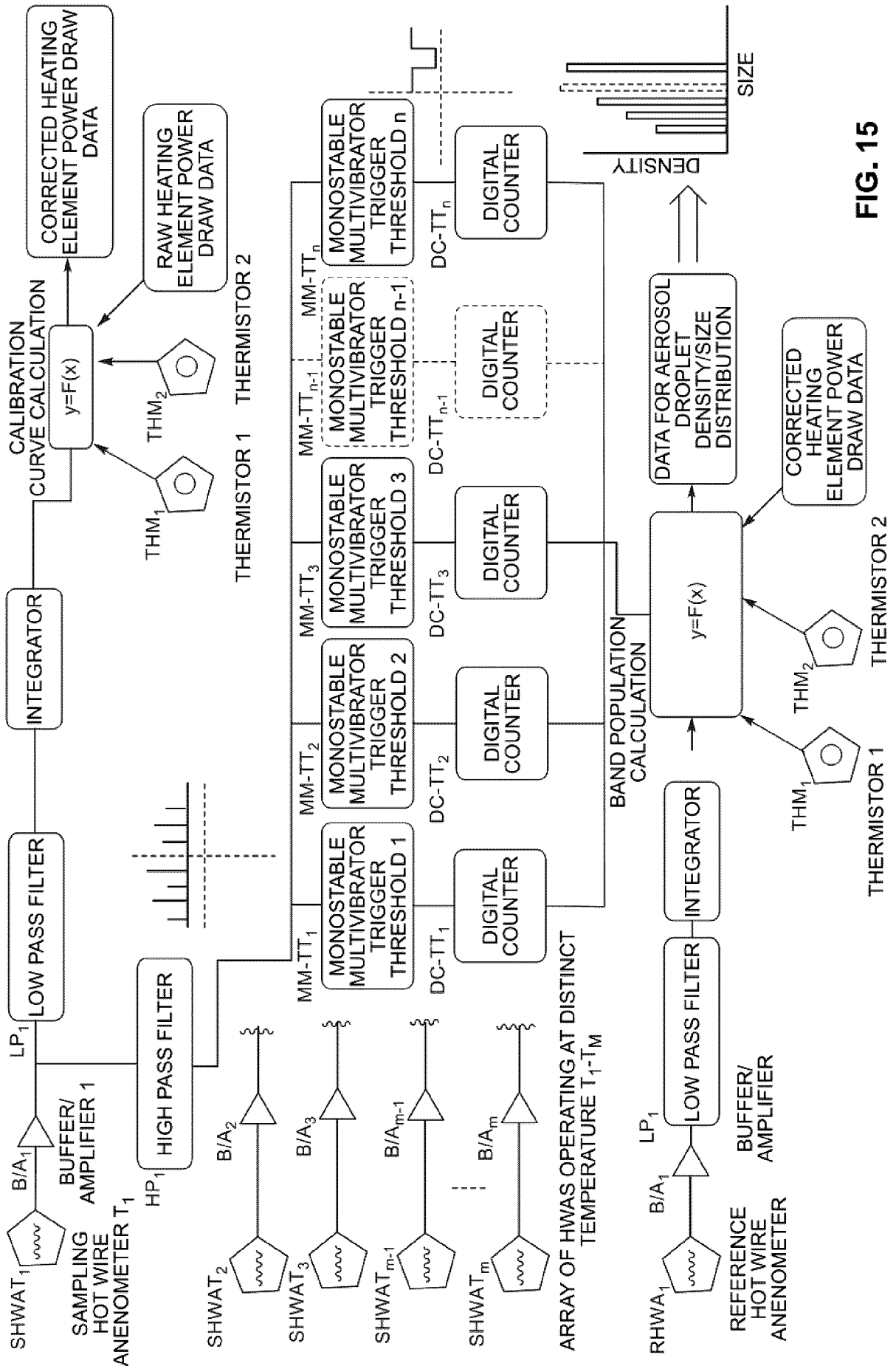

FIG. 15

INTERNATIONAL SEARCH REPORT

International application No.
PCT/CA2020/050292

A. CLASSIFICATION OF SUBJECT MATTER

IPC: *G01N 15/06* (2006.01), *A24F 40/40* (2020.01), *G01F 1/86* (2006.01), *G01F 1/88* (2006.01),
G01G 17/04 (2006.01), *G01N 15/02* (2006.01) (more IPCs on the last page)

According to International Patent Classification (IPC) or to both national classification and IPC

B. FIELDS SEARCHED

Minimum documentation searched (classification system followed by classification symbols)
Keywords searched across all of IPC.

Documentation searched other than minimum documentation to the extent that such documents are included in the fields searched

Electronic database(s) consulted during the international search (name of database(s) and, where practicable, search terms used)

Databases: Esp@cenet, Questel Orbit, Google

Keywords: vape device, electronic cigarette, dosimeter, dose control, thermal properties, power, energy, etc.

C. DOCUMENTS CONSIDERED TO BE RELEVANT

Category*	Citation of document, with indication, where appropriate, of the relevant passages	Relevant to claim No.
[X]	WO2016/090303 A1 (BOWEN et al.) 9 June 2016 (09-06-2016) *entire document, especially: abstract; [0011], [0013], [0019], [0029]; Figs 1A, 1B*	1-77
[Y]	US 2018/0263283 A1 (POPPLEWELL et al.) 20 September 2018 (20-09-2018) *entire document, especially: [0015], [0030], [0033], [0070], [0092]*	1-77
[Y]	US 2018/0093054 A1 (BOWEN et al.) 5 April 2018 (05-04-2018) * [0005], [0043], [0045], [0108], [0086], [0089-91], [0099], [0130], [0170]*	1-77
[Y]	US 2017/0156399 A1 (FREEMAN et al.) 8 June 2017 (08-06-2017) *entire document, especially: [0031-32]*	24-77
[Y]	US 6840116 B2 (HIGGINS) 11 January 2005 (11-01-2005) *entire document, abstract*	33-77

 Further documents are listed in the continuation of Box C. See patent family annex.

* Special categories of cited documents:	“T” later document published after the international filing date or priority date and not in conflict with the application but cited to understand the principle or theory underlying the invention
“A” document defining the general state of the art which is not considered to be of particular relevance	“X” document of particular relevance; the claimed invention cannot be considered novel or cannot be considered to involve an inventive step when the document is taken alone
“D” document cited by the applicant in the international application	“Y” document of particular relevance; the claimed invention cannot be considered to involve an inventive step when the document is combined with one or more other such documents, such combination being obvious to a person skilled in the art
“E” earlier application or patent but published on or after the international filing date	“&” document member of the same patent family
“L” document which may throw doubts on priority claim(s) or which is cited to establish the publication date of another citation or other special reason (as specified)	
“O” document referring to an oral disclosure, use, exhibition or other means	
“P” document published prior to the international filing date but later than the priority date claimed	

Date of the actual completion of the international search
14 May 2020 (14-05-2020)Date of mailing of the international search report
20 May 2020 (20-05-2020)Name and mailing address of the ISA/CA
Canadian Intellectual Property Office
Place du Portage I, C114 - 1st Floor, Box PCT
50 Victoria Street
Gatineau, Quebec K1A 0C9
Facsimile No.: 819-953-2476

Authorized officer

Anthony Glaser (819) 639-3193

Box No. II Observations where certain claims were found unsearchable (Continuation of item 2 of the first sheet)

This international search report has not been established in respect of certain claims under Article 17(2)(a) for the following reasons:

1. Claim Nos.:
because they relate to subject matter not required to be searched by this Authority, namely:

2. Claim Nos.:
because they relate to parts of the international application that do not comply with the prescribed requirements to such an extent that no meaningful international search can be carried out, specifically:

3. Claim Nos.:
because they are dependent claims and are not drafted in accordance with the second and third sentences of Rule 6.4(a).

Box No. III Observations where unity of invention is lacking (Continuation of item 3 of first sheet)

This International Searching Authority found multiple inventions in this international application, as follows:

Group A - Claims 1-77 are directed to determining payload dose in a vape device from energy to vaporize partial mass of payload;
 Group B - Claims 78-156 are directed to determining payload dose in a vape device from temperature measurements and air flow rates;
 Group C - Claims 157-236 are directed to determining payload dose in a vape device from light intensity measurements; and
 Group D - Claims 237- 315 are directed to determining payload dose in a vape device from hot wire anemometer measurements.

1. As all required additional search fees were timely paid by the applicant, this international search report covers all searchable claims.
2. As all searchable claims could be searched without effort justifying additional fees, this Authority did not invite payment of additional fees.
3. As only some of the required additional search fees were timely paid by the applicant, this international search report covers only those claims for which fees were paid, specifically claim Nos.:

4. No required additional search fees were timely paid by the applicant. Consequently, this international search report is restricted to the invention first mentioned in the claims; it is covered by claim Nos.:

1 - 77

- Remark on Protest**
- The additional search fees were accompanied by the applicant's protest and, where applicable, the payment of a protest fee.
 - The additional search fees were accompanied by the applicant's protest but the applicable protest fee was not paid within the time limit specified in the invitation.
 - No protest accompanied the payment of additional search fees.

INTERNATIONAL SEARCH REPORT
Information on patent family members

International application No.
PCT/CA2020/050292

Patent Document Cited in Search Report	Publication Date	Patent Family Member(s)	Publication Date
WO2016090303A1	09 June 2016 (09-06-2016)	AR089648A1	10 September 2014 (10-09-2014)
		AT16038U2	15 September 2018 (15-09-2018)
		AT16038U3	15 February 2019 (15-02-2019)
		AT16039U2	15 September 2018 (15-09-2018)
		AT16039U3	15 February 2019 (15-02-2019)
		AT16040U2	15 September 2018 (15-09-2018)
		AT16040U3	15 February 2019 (15-02-2019)
		AU2006269882A1	25 January 2007 (25-01-2007)
		AU2006269882B2	02 February 2012 (02-02-2012)
		AU2008338305A1	25 June 2009 (25-06-2009)
		AU2014262808A1	12 November 2015 (12-11-2015)
		AU2014262808B2	13 December 2018 (13-12-2018)
		AU2014357622A1	16 June 2016 (16-06-2016)
		AU2014357622B2	24 October 2019 (24-10-2019)
		AU2014369867A1	16 June 2016 (16-06-2016)
		AU2015357509A1	29 June 2017 (29-06-2017)
		AU2019201728A1	04 April 2019 (04-04-2019)
		AU2019246867A1	31 October 2019 (31-10-2019)
		AU2020200425A1	13 February 2020 (13-02-2020)
		BR112018016402A2	18 December 2018 (18-12-2018)
		BR112018016412A2	26 December 2018 (26-12-2018)
		BR112018016413A2	26 December 2018 (26-12-2018)
		BR112018067606A2	08 January 2019 (08-01-2019)
		CA2616120A1	25 January 2007 (25-01-2007)
		CA2712469A1	25 June 2010 (25-06-2010)
		CA2712469C	13 December 2016 (13-12-2016)
		CA2845090A1	21 February 2013 (21-02-2013)
		CA2909967A1	13 November 2014 (13-11-2014)
		CA2932464A1	11 June 2015 (11-06-2015)
		CA2933906A1	02 July 2015 (02-07-2015)
		CA2969728A1	09 June 2016 (09-06-2016)
		CL2018002292A1	21 December 2018 (21-12-2018)
		CL2018002293A1	21 December 2018 (21-12-2018)
		CL2018002294A1	21 December 2018 (21-12-2018)
		CL2018002421A1	14 December 2018 (14-12-2018)
		CN101282660A	08 October 2008 (08-10-2008)
		CN101282660B	20 May 2015 (20-05-2015)
		CN101951796A	19 January 2011 (19-01-2011)
		CN101951796B	03 February 2016 (03-02-2016)
		CN102697184A	03 October 2012 (03-10-2012)
		CN102697184B	14 December 2016 (14-12-2016)
		CN103948170A	30 July 2014 (30-07-2014)
		CN103948170B	13 November 2018 (13-11-2018)
		CN104705793A	17 June 2015 (17-06-2015)
		CN104705793B	20 August 2019 (20-08-2019)
		CN105263345A	20 January 2016 (20-01-2016)
		CN105473012A	06 April 2016 (06-04-2016)
		CN105661645A	15 June 2016 (15-06-2016)
		CN105661645B	21 April 2020 (21-04-2020)
		CN105979805A	28 September 2016 (28-09-2016)
		CN106028846A	12 October 2016 (12-10-2016)
		CN107427067A	01 December 2017 (01-12-2017)
		CN110269282A	24 September 2019 (24-09-2019)
		CN110313645A	11 October 2019 (11-10-2019)
		CN110313646A	11 October 2019 (11-10-2019)
		CN110326819A	15 October 2019 (15-10-2019)
CN110537734A	06 December 2019 (06-12-2019)		

INTERNATIONAL SEARCH REPORT

International application No.

PCT/CA2020/050292

Patent Document Cited in Search Report	Publication Date	Patent Family Member(s)	Publication Date
		CN110537735A	06 December 2019 (06-12-2019)
		CN110537736A	06 December 2019 (06-12-2019)
		CN110537737A	06 December 2019 (06-12-2019)
		CN110638106A	03 January 2020 (03-01-2020)
		CN110638107A	03 January 2020 (03-01-2020)
		CN110638108A	03 January 2020 (03-01-2020)
		CN110638109A	03 January 2020 (03-01-2020)
		CN110664011A	10 January 2020 (10-01-2020)
		CN110664012A	10 January 2020 (10-01-2020)
		CN110664013A	10 January 2020 (10-01-2020)
		CN110710714A	21 January 2020 (21-01-2020)
		CN110710715A	21 January 2020 (21-01-2020)
		CN110710716A	21 January 2020 (21-01-2020)
		CN110710727A	21 January 2020 (21-01-2020)
		CN204275207U	22 April 2015 (22-04-2015)
		CO2018009342A2	20 September 2018 (20-09-2018)
		CO2018009343A2	20 September 2018 (20-09-2018)
		DE202012013641U1	16 November 2018 (16-11-2018)
		DE202012013645U1	22 November 2018 (22-11-2018)
		DE202014011205U1	13 September 2018 (13-09-2018)
		DE202014011221U1	13 September 2018 (13-09-2018)
		DE202014011232U1	13 September 2018 (13-09-2018)
		DE202014011257U1	07 November 2018 (07-11-2018)
		DE202014011258U1	08 November 2018 (08-11-2018)
		DE202014011260U1	13 November 2018 (13-11-2018)
		DE202014011261U1	13 November 2018 (13-11-2018)
		DE202014011264U1	06 December 2018 (06-12-2018)
		DE202014011265U1	06 December 2018 (06-12-2018)
		DE202014011267U1	06 December 2018 (06-12-2018)
		DE202014011292U1	01 February 2019 (01-02-2019)
		DE202014011294U1	07 February 2019 (07-02-2019)
		DE202014011295U1	07 February 2019 (07-02-2019)
		DE202014011296U1	08 February 2019 (08-02-2019)
		DE202014011297U1	13 February 2019 (13-02-2019)
		DE202014011309U1	29 March 2019 (29-03-2019)
		DE202014011310U1	29 March 2019 (29-03-2019)
		DE202014011311U1	29 March 2019 (29-03-2019)
		DE202014011313U1	29 March 2019 (29-03-2019)
		DE202017006972U1	25 January 2019 (25-01-2019)
		DK3086671T3	21 January 2019 (21-01-2019)
		DK3311684T3	03 June 2019 (03-06-2019)
		EA201490448A1	30 December 2014 (30-12-2014)
		EA028767B1	29 December 2017 (29-12-2017)
		EA201791917A2	31 January 2018 (31-01-2018)
		EA201791917A3	31 January 2019 (31-01-2019)
		EA201891790A1	28 February 2019 (28-02-2019)
		EA201891791A1	28 February 2019 (28-02-2019)
		EP1959766A2	27 August 2008 (27-08-2008)
		EP1959766A4	01 May 2013 (01-05-2013)
		EP1959766B1	03 September 2014 (03-09-2014)
		EP2234508A2	06 October 2010 (06-10-2010)
		EP2234508A4	13 November 2013 (13-11-2013)
		EP2723429A1	30 April 2014 (30-04-2014)
		EP2723429A4	01 April 2015 (01-04-2015)
		EP2727619A2	07 May 2014 (07-05-2014)
		EP2727619A3	23 July 2014 (23-07-2014)
		EP2727619B1	22 March 2017 (22-03-2017)

INTERNATIONAL SEARCH REPORT

International application No.

PCT/CA2020/050292

Patent Document Cited in Search Report	Publication Date	Patent Family Member(s)	Publication Date
		EP2740506A1	11 June 2014 (11-06-2014)
		EP2740507A1	11 June 2014 (11-06-2014)
		EP2740507B1	11 January 2017 (11-01-2017)
		EP2740508A1	11 June 2014 (11-06-2014)
		EP2740508B1	15 June 2016 (15-06-2016)
		EP2754360A1	16 July 2014 (16-07-2014)
		EP2754360B1	29 November 2017 (29-11-2017)
		EP2756859A1	23 July 2014 (23-07-2014)
		EP2756859B1	21 September 2016 (21-09-2016)
		EP2756860A1	23 July 2014 (23-07-2014)
		EP2756860B1	21 September 2016 (21-09-2016)
		EP2772148A2	03 September 2014 (03-09-2014)
		EP2772148A3	05 November 2014 (05-11-2014)
		EP2772148B1	03 May 2017 (03-05-2017)
		EP2910135A1	26 August 2015 (26-08-2015)
		EP2910135B1	19 June 2019 (19-06-2019)
		EP2993999A1	16 March 2016 (16-03-2016)
		EP2993999A4	27 December 2017 (27-12-2017)
		EP3076805A1	12 October 2016 (12-10-2016)
		EP3076805A4	11 October 2017 (11-10-2017)
		EP3086671A1	02 November 2016 (02-11-2016)
		EP3086671A4	09 August 2017 (09-08-2017)
		EP3086671B1	26 September 2018 (26-09-2018)
		EP3153039A1	12 April 2017 (12-04-2017)
		EP3226704A1	11 October 2017 (11-10-2017)
		EP3226704A4	25 July 2018 (25-07-2018)
		EP3311684A1	25 April 2018 (25-04-2018)
		EP3311684B1	13 March 2019 (13-03-2019)
		EP3413735A1	19 December 2018 (19-12-2018)
		EP3413735A4	25 September 2019 (25-09-2019)
		EP3413960A1	19 December 2018 (19-12-2018)
		EP3413960A4	23 October 2019 (23-10-2019)
		EP3419443A1	02 January 2019 (02-01-2019)
		EP3419443A4	20 November 2019 (20-11-2019)
		EP3419449A1	02 January 2019 (02-01-2019)
		EP3419449A4	20 November 2019 (20-11-2019)
		EP3430921A1	23 January 2019 (23-01-2019)
		EP3488712A1	29 May 2019 (29-05-2019)
		EP3488716A1	29 May 2019 (29-05-2019)
		EP3488716B1	11 March 2020 (11-03-2020)
		EP3488717A1	29 May 2019 (29-05-2019)
		EP3491947A1	05 June 2019 (05-06-2019)
		EP3491948A1	05 June 2019 (05-06-2019)
		EP3494817A1	12 June 2019 (12-06-2019)
		EP3494818A1	12 June 2019 (12-06-2019)
		EP3498115A1	19 June 2019 (19-06-2019)
		EP3504989A1	03 July 2019 (03-07-2019)
		EP3504990A1	03 July 2019 (03-07-2019)
		EP3504991A1	03 July 2019 (03-07-2019)
		EP3508080A1	10 July 2019 (10-07-2019)
		EP3513673A1	24 July 2019 (24-07-2019)
		EP3536174A1	11 September 2019 (11-09-2019)
		EP3581041A1	18 December 2019 (18-12-2019)
		EP3613301A1	26 February 2020 (26-02-2020)
		ES2586141T3	11 October 2016 (11-10-2016)
		ES2621888T3	05 July 2017 (05-07-2017)
		ES2653958T3	09 February 2018 (09-02-2018)

INTERNATIONAL SEARCH REPORT

International application No.

PCT/CA2020/050292

Patent Document Cited in Search Report	Publication Date	Patent Family Member(s)	Publication Date
		ES2703823T3	12 March 2019 (12-03-2019)
		ES2728270T3	23 October 2019 (23-10-2019)
		GB201612702D0	07 September 2016 (07-09-2016)
		GB2538424A	16 November 2016 (16-11-2016)
		GB2538424B	24 October 2018 (24-10-2018)
		GB2538424A8	19 December 2018 (19-12-2018)
		GB2538424B8	19 December 2018 (19-12-2018)
		GB201804595D0	09 May 2018 (09-05-2018)
		GB2558804A	18 July 2018 (18-07-2018)
		GB2558804B	12 December 2018 (12-12-2018)
		GB2558804A8	19 December 2018 (19-12-2018)
		GB2558804B8	19 December 2018 (19-12-2018)
		GB201804597D0	09 May 2018 (09-05-2018)
		GB2558805A	18 July 2018 (18-07-2018)
		GB2558805B	03 October 2018 (03-10-2018)
		GB2558805A8	19 December 2018 (19-12-2018)
		GB2558805B8	19 December 2018 (19-12-2018)
		GB201804598D0	09 May 2018 (09-05-2018)
		GB2558806A	18 July 2018 (18-07-2018)
		GB2558806B	03 October 2018 (03-10-2018)
		GB2558806A8	19 December 2018 (19-12-2018)
		GB2558806B8	19 December 2018 (19-12-2018)
		GB201804599D0	09 May 2018 (09-05-2018)
		GB2558807A	18 July 2018 (18-07-2018)
		GB2558807B	03 October 2018 (03-10-2018)
		GB2558807A8	19 December 2018 (19-12-2018)
		GB2558807B8	19 December 2018 (19-12-2018)
		GB201806653D0	06 June 2018 (06-06-2018)
		GB2559506A	08 August 2018 (08-08-2018)
		GB2559506A8	19 December 2018 (19-12-2018)
		GB201806654D0	06 June 2018 (06-06-2018)
		GB2559507A	08 August 2018 (08-08-2018)
		GB2559507B	05 December 2018 (05-12-2018)
		GB2559507A8	19 December 2018 (19-12-2018)
		GB2559507B8	19 December 2018 (19-12-2018)
		GB201808363D0	11 July 2018 (11-07-2018)
		GB2560465A	12 September 2018 (12-09-2018)
		GB2560465B	31 October 2018 (31-10-2018)
		GB2560465A8	19 December 2018 (19-12-2018)
		GB2560465B8	19 December 2018 (19-12-2018)
		GB201721768D0	07 February 2018 (07-02-2018)
		GB2560606A	19 September 2018 (19-09-2018)
		GB2560606B	31 October 2018 (31-10-2018)
		GB2560606A8	19 December 2018 (19-12-2018)
		GB2560606B8	19 December 2018 (19-12-2018)
		GB201721774D0	07 February 2018 (07-02-2018)
		GB2560607A	19 September 2018 (19-09-2018)
		GB2560607B	14 November 2018 (14-11-2018)
		GB2560607A8	19 December 2018 (19-12-2018)
		GB2560607B8	19 December 2018 (19-12-2018)
		GB201806770D0	06 June 2018 (06-06-2018)
		GB2560651A	19 September 2018 (19-09-2018)
		GB2560651B	05 December 2018 (05-12-2018)
		GB2560651A8	19 December 2018 (19-12-2018)
		GB2560651B8	19 December 2018 (19-12-2018)
		GB201806827D0	13 June 2018 (13-06-2018)
		GB2560652A	19 September 2018 (19-09-2018)

INTERNATIONAL SEARCH REPORT

International application No.

PCT/CA2020/050292

Patent Document Cited in Search Report	Publication Date	Patent Family Member(s)	Publication Date
		GB2560652B	05 December 2018 (05-12-2018)
		GB2560652A8	19 December 2018 (19-12-2018)
		GB2560652B8	19 December 2018 (19-12-2018)
		GB201807470D0	20 June 2018 (20-06-2018)
		GB2560653A	19 September 2018 (19-09-2018)
		GB2560653B	31 October 2018 (31-10-2018)
		GB2560653A8	19 December 2018 (19-12-2018)
		GB2560653B8	19 December 2018 (19-12-2018)
		GB201808452D0	11 July 2018 (11-07-2018)
		GB2560660A	19 September 2018 (19-09-2018)
		GB2560660B	31 October 2018 (31-10-2018)
		GB2560660A8	19 December 2018 (19-12-2018)
		GB2560660B8	19 December 2018 (19-12-2018)
		HK1197203A1	09 January 2015 (09-01-2015)
		HK1198138A1	13 March 2015 (13-03-2015)
		HK1198142A1	13 March 2015 (13-03-2015)
		HK1198143A1	13 March 2015 (13-03-2015)
		HK1198329A1	02 April 2015 (02-04-2015)
		HK1200063A1	31 July 2015 (31-07-2015)
		HK1200128A1	31 July 2015 (31-07-2015)
		HK1200129A1	31 July 2015 (31-07-2015)
		HK1222516A1	07 July 2017 (07-07-2017)
		HUE042629T2	29 July 2019 (29-07-2019)
		HUE043189T2	28 August 2019 (28-08-2019)
		IL230930D0	31 March 2014 (31-03-2014)
		IL230930A	29 June 2017 (29-06-2017)
		IL245912D0	31 July 2016 (31-07-2016)
		IL246404D0	31 August 2016 (31-08-2016)
		IL246404A	30 May 2019 (30-05-2019)
		IL252658D0	31 July 2017 (31-07-2017)
		IL252776D0	31 August 2017 (31-08-2017)
		IL266354D0	30 June 2019 (30-06-2019)
		IL267749D0	29 August 2019 (29-08-2019)
		IL267750D0	29 August 2019 (29-08-2019)
		IL267751D0	29 August 2019 (29-08-2019)
		IL267753D0	29 August 2019 (29-08-2019)
		IL267754D0	29 August 2019 (29-08-2019)
		IL267755D0	29 August 2019 (29-08-2019)
		IL271562D0	27 February 2020 (27-02-2020)
		IL271563D0	27 February 2020 (27-02-2020)
		IL271565D0	27 February 2020 (27-02-2020)
		IL271567D0	27 February 2020 (27-02-2020)
		IL271569D0	27 February 2020 (27-02-2020)
		IL271572D0	27 February 2020 (27-02-2020)
		IL271578D0	27 February 2020 (27-02-2020)
		IL271580D0	27 February 2020 (27-02-2020)
		JP2009502136A	29 January 2009 (29-01-2009)
		JP5107245B2	26 December 2012 (26-12-2012)
		JP2012152224A	16 August 2012 (16-08-2012)
		JP5548233B2	16 July 2014 (16-07-2014)
		JP2014076065A	01 May 2014 (01-05-2014)
		JP5853036B2	09 February 2016 (09-02-2016)
		JP2014524313A	22 September 2014 (22-09-2014)
		JP6138123B2	31 May 2017 (31-05-2017)
		JP2015057078A	26 March 2015 (26-03-2015)
		JP6176737B2	09 August 2017 (09-08-2017)
		JP2016520061A	11 July 2016 (11-07-2016)

INTERNATIONAL SEARCH REPORT

International application No.

PCT/CA2020/050292

Patent Document Cited in Search Report	Publication Date	Patent Family Member(s)	Publication Date
		JP6400678B2	03 October 2018 (03-10-2018)
		JP2017148065A	31 August 2017 (31-08-2017)
		JP6495370B2	03 April 2019 (03-04-2019)
		JP2017501805A	19 January 2017 (19-01-2017)
		JP6653432B2	26 February 2020 (26-02-2020)
		JP2011505874A	03 March 2011 (03-03-2011)
		JP2015213516A	03 December 2015 (03-12-2015)
		JP2016539645A	22 December 2016 (22-12-2016)
		JP2017221213A	21 December 2017 (21-12-2017)
		JP2017538410A	28 December 2017 (28-12-2017)
		JP2019030301A	28 February 2019 (28-02-2019)
		JP2019150023A	12 September 2019 (12-09-2019)
		JP2020062042A	23 April 2020 (23-04-2020)
		KR20080060218A	01 July 2008 (01-07-2008)
		KR101473013B1	15 December 2014 (15-12-2014)
		KR20160075770A	29 June 2016 (29-06-2016)
		KR101951529B1	22 February 2019 (22-02-2019)
		KR20140072221A	12 June 2014 (12-06-2014)
		KR102014889B1	27 August 2019 (27-08-2019)
		KR20190000393A	02 January 2019 (02-01-2019)
		KR102072325B1	31 January 2020 (31-01-2020)
		KR20100108565A	07 October 2010 (07-10-2010)
		KR20140090138A	16 July 2014 (16-07-2014)
		KR20150013933A	05 February 2015 (05-02-2015)
		KR20160004298A	12 January 2016 (12-01-2016)
		KR20160093717A	08 August 2016 (08-08-2016)
		KR20160102293A	29 August 2016 (29-08-2016)
		KR20170091737A	09 August 2017 (09-08-2017)
		KR20180132968A	12 December 2018 (12-12-2018)
		KR20190000394A	02 January 2019 (02-01-2019)
		KR20190000395A	02 January 2019 (02-01-2019)
		KR20190000899A	03 January 2019 (03-01-2019)
		KR20190000900A	03 January 2019 (03-01-2019)
		KR20190000901A	03 January 2019 (03-01-2019)
		KR20190000902A	03 January 2019 (03-01-2019)
		KR20190105123A	11 September 2019 (11-09-2019)
		KR20190121868A	28 October 2019 (28-10-2019)
		KR20190130072A	20 November 2019 (20-11-2019)
		KR20190130073A	20 November 2019 (20-11-2019)
		KR20190130074A	20 November 2019 (20-11-2019)
		KR20190130075A	20 November 2019 (20-11-2019)
		KR20190130076A	20 November 2019 (20-11-2019)
		KR20190130667A	22 November 2019 (22-11-2019)
		KR20190130668A	22 November 2019 (22-11-2019)
		LT3086671T	11 February 2019 (11-02-2019)
		LT3311684T	27 May 2019 (27-05-2019)
		MX2015015175A	12 January 2016 (12-01-2016)
		MX2016007283A	06 January 2017 (06-01-2017)
		MX2016008354A	14 October 2016 (14-10-2016)
		MX2017007042A	15 June 2018 (15-06-2018)
		MX2018009702A	08 July 2019 (08-07-2019)
		MX2018009703A	08 July 2019 (08-07-2019)
		MX2018009704A	08 July 2019 (08-07-2019)
		MX2018010186A	14 January 2019 (14-01-2019)
		PL2754360T3	30 March 2018 (30-03-2018)
		PL3086671T3	31 May 2019 (31-05-2019)
		PL3086671T4	31 May 2019 (31-05-2019)

INTERNATIONAL SEARCH REPORT

International application No.

PCT/CA2020/050292

Patent Document Cited in Search Report	Publication Date	Patent Family Member(s)	Publication Date
		PL3311684T3	30 September 2019 (30-09-2019)
		PT3086671T	23 January 2019 (23-01-2019)
		PT3311684T	05 June 2019 (05-06-2019)
		RU157882U1	20 December 2015 (20-12-2015)
		RU2015146869A	15 June 2017 (15-06-2017)
		RU2659887C2	04 July 2018 (04-07-2018)
		RU2017123539A	09 January 2019 (09-01-2019)
		RU2017123539A3	01 April 2019 (01-04-2019)
		RU2709926C2	23 December 2019 (23-12-2019)
		RU2019140840A	03 March 2020 (03-03-2020)
		SG2014013627A	30 July 2014 (30-07-2014)
		SG11201806793TA	27 September 2018 (27-09-2018)
		SG11201806801VA	27 September 2018 (27-09-2018)
		SG11201806807UA	27 September 2018 (27-09-2018)
		SG11201807028YA	27 September 2018 (27-09-2018)
		SI3311684T1	31 July 2019 (31-07-2019)
		TR201907479T4	21 June 2019 (21-06-2019)
		TW200944142A	01 November 2009 (01-11-2009)
		TW1522051B	21 February 2016 (21-02-2016)
		TW201315397A	16 April 2013 (16-04-2013)
		TW1593365B	01 August 2017 (01-08-2017)
		TW201540203A	01 November 2015 (01-11-2015)
		TW1684414B	11 February 2020 (11-02-2020)
		TW201733467A	01 October 2017 (01-10-2017)
		UA112319C2	25 August 2016 (25-08-2016)
		UA118686C2	25 February 2019 (25-02-2019)
		USD825102S	07 August 2018 (07-08-2018)
		USD842536S	05 March 2019 (05-03-2019)
		USD858868S	03 September 2019 (03-09-2019)
		USD858869S	03 September 2019 (03-09-2019)
		USD858870S	03 September 2019 (03-09-2019)
		USD861975S	01 October 2019 (01-10-2019)
		US2009260641A1	22 October 2009 (22-10-2009)
		US8915254B2	23 December 2014 (23-12-2014)
		US2009260642A1	22 October 2009 (22-10-2009)
		US8925555B2	06 January 2015 (06-01-2015)
		US2009151717A1	18 June 2009 (18-06-2009)
		US8991402B2	31 March 2015 (31-03-2015)
		US2015020824A1	22 January 2015 (22-01-2015)
		US9215895B2	22 December 2015 (22-12-2015)
		US2013042865A1	21 February 2013 (21-02-2013)
		US9408416B2	09 August 2016 (09-08-2016)
		US2016174611A1	23 June 2016 (23-06-2016)
		US9549573B2	24 January 2017 (24-01-2017)
		US2007283972A1	13 December 2007 (13-12-2007)
		US9675109B2	13 June 2017 (13-06-2017)
		US2018070643A1	15 March 2018 (15-03-2018)
		US10045567B2	14 August 2018 (14-08-2018)
		US2018103686A1	19 April 2018 (19-04-2018)
		US10045568B2	14 August 2018 (14-08-2018)
		US2015208729A1	30 July 2015 (30-07-2015)
		US10058124B2	28 August 2018 (28-08-2018)
		US2017095005A1	06 April 2017 (06-04-2017)
		US10058129B2	28 August 2018 (28-08-2018)
		US2018070642A1	15 March 2018 (15-03-2018)
		US10058130B2	28 August 2018 (28-08-2018)
		US2018070649A1	15 March 2018 (15-03-2018)

INTERNATIONAL SEARCH REPORT

International application No.

PCT/CA2020/050292

Patent Document Cited in Search Report	Publication Date	Patent Family Member(s)	Publication Date
		US10070669B2	11 September 2018 (11-09-2018)
		US2016374399A1	29 December 2016 (29-12-2016)
		US10076139B2	18 September 2018 (18-09-2018)
		US2018070646A1	15 March 2018 (15-03-2018)
		US10104915B2	23 October 2018 (23-10-2018)
		US2018116291A1	03 May 2018 (03-05-2018)
		US10111470B2	30 October 2018 (30-10-2018)
		US2018064175A1	08 March 2018 (08-03-2018)
		US10117465B2	06 November 2018 (06-11-2018)
		US2018070645A1	15 March 2018 (15-03-2018)
		US10117466B2	06 November 2018 (06-11-2018)
		US2017231281A1	17 August 2017 (17-08-2017)
		US10130123B2	20 November 2018 (20-11-2018)
		US2017035115A1	09 February 2017 (09-02-2017)
		US10159282B2	25 December 2018 (25-12-2018)
		US2018070644A1	15 March 2018 (15-03-2018)
		US10201190B2	12 February 2019 (12-02-2019)
		US2015157056A1	11 June 2015 (11-06-2015)
		US10231484B2	19 March 2019 (19-03-2019)
		US2016338412A1	24 November 2016 (24-11-2016)
		US10244793B2	02 April 2019 (02-04-2019)
		US2018070647A1	15 March 2018 (15-03-2018)
		US10264823B2	23 April 2019 (23-04-2019)
		US2017233114A1	17 August 2017 (17-08-2017)
		US10279934B2	07 May 2019 (07-05-2019)
		US2016302471A1	20 October 2016 (20-10-2016)
		US10463069B2	05 November 2019 (05-11-2019)
		US2016157524A1	09 June 2016 (09-06-2016)
		US10512282B2	24 December 2019 (24-12-2019)
		US2014378790A1	25 December 2014 (25-12-2014)
		US10517530B2	31 December 2019 (31-12-2019)
		US2017231282A1	17 August 2017 (17-08-2017)
		US10638792B2	05 May 2020 (05-05-2020)
		US2013312742A1	28 November 2013 (28-11-2013)
		US2014060552A1	06 March 2014 (06-03-2014)
		US2014345631A1	27 November 2014 (27-11-2014)
		US2014366898A1	18 December 2014 (18-12-2014)
		US2015150308A1	04 June 2015 (04-06-2015)
		US2016044967A1	18 February 2016 (18-02-2016)
		US2016044968A1	18 February 2016 (18-02-2016)
		US2016262459A1	15 September 2016 (15-09-2016)
		US2016345631A1	01 December 2016 (01-12-2016)
		US2016366947A1	22 December 2016 (22-12-2016)
		US2016374400A1	29 December 2016 (29-12-2016)
		US2017079331A1	23 March 2017 (23-03-2017)
		US2018064174A1	08 March 2018 (08-03-2018)
		US2018070648A1	15 March 2018 (15-03-2018)
		US2018092405A1	05 April 2018 (05-04-2018)
		US2018092406A1	05 April 2018 (05-04-2018)
		US2018098578A1	12 April 2018 (12-04-2018)
		US2018317557A1	08 November 2018 (08-11-2018)
		US2018360129A1	20 December 2018 (20-12-2018)
		US2018360130A1	20 December 2018 (20-12-2018)
		US2019000148A1	03 January 2019 (03-01-2019)
		US2019008212A1	10 January 2019 (10-01-2019)
		US2019069599A1	07 March 2019 (07-03-2019)
		US2019104767A1	11 April 2019 (11-04-2019)

INTERNATIONAL SEARCH REPORT

International application No.

PCT/CA2020/050292

Patent Document Cited in Search Report	Publication Date	Patent Family Member(s)	Publication Date
		US2019223510A1	25 July 2019 (25-07-2019)
		US2019256231A1	22 August 2019 (22-08-2019)
		US2019261686A1	29 August 2019 (29-08-2019)
		US2019289916A1	26 September 2019 (26-09-2019)
		US2020022400A1	23 January 2020 (23-01-2020)
		US2020120987A1	23 April 2020 (23-04-2020)
		US2020129116A1	30 April 2020 (30-04-2020)
		WO2007012007A2	25 January 2007 (25-01-2007)
		WO2007012007A3	01 November 2007 (01-11-2007)
		WO2007012007A8	28 February 2008 (28-02-2008)
		WO2009079641A2	25 June 2009 (25-06-2009)
		WO2009079641A3	03 September 2009 (03-09-2009)
		WO2013025921A1	21 February 2013 (21-02-2013)
		WO2014182736A1	13 November 2014 (13-11-2014)
		WO2014201432A1	18 December 2014 (18-12-2014)
		WO2015084544A1	11 June 2015 (11-06-2015)
		WO2015100361A1	02 July 2015 (02-07-2015)
		WO2017139595A1	17 August 2017 (17-08-2017)
		WO2017139662A1	17 August 2017 (17-08-2017)
		WO2017139675A1	17 August 2017 (17-08-2017)
		WO2017147560A1	31 August 2017 (31-08-2017)
		WO2017205838A1	30 November 2017 (30-11-2017)
		WO2018048813A1	15 March 2018 (15-03-2018)
		ZA201401146B	29 July 2015 (29-07-2015)
US2018263283A1	20 September 2018 (20-09-2018)	US10327479B2	25 June 2019 (25-06-2019)
		AU2018233586A1	10 October 2019 (10-10-2019)
		BR112019019119A2	14 April 2020 (14-04-2020)
		CA3056499A1	20 September 2018 (20-09-2018)
		CL2019002628A1	13 December 2019 (13-12-2019)
		CO2019009991A2	30 September 2019 (30-09-2019)
		EP3595468A1	22 January 2020 (22-01-2020)
		IL269285D0	28 November 2019 (28-11-2019)
		KR20190131053A	25 November 2019 (25-11-2019)
		MX2019010792A	24 October 2019 (24-10-2019)
		PE20191446A1	15 October 2019 (15-10-2019)
		TW201944911A	01 December 2019 (01-12-2019)
		US2019272359A1	05 September 2019 (05-09-2019)
		WO2018165758A1	20 September 2018 (20-09-2018)
		WO2019173923A1	19 September 2019 (19-09-2019)
US2018093054A1	05 April 2018 (05-04-2018)	AU2017268810A1	20 December 2018 (20-12-2018)
		BR112018074122A2	06 March 2019 (06-03-2019)
		CA3025407A1	30 November 2017 (30-11-2017)
		CN109963606A	02 July 2019 (02-07-2019)
		DE112017002267T5	10 January 2019 (10-01-2019)
		EA201892738A1	31 May 2019 (31-05-2019)
		EP3463535A1	10 April 2019 (10-04-2019)
		GB201819107D0	09 January 2019 (09-01-2019)
		GB2566185A	06 March 2019 (06-03-2019)
		IL263198D0	31 December 2018 (31-12-2018)
		JP2019521739A	08 August 2019 (08-08-2019)
		KR20190011264A	01 February 2019 (01-02-2019)
		MX2018014354A	11 April 2019 (11-04-2019)
		PH12018502492A1	15 July 2019 (15-07-2019)
		SG11201810438VA	28 December 2018 (28-12-2018)
		TW201808373A	16 March 2018 (16-03-2018)

INTERNATIONAL SEARCH REPORT

International application No.

PCT/CA2020/050292

Patent Document Cited in Search Report	Publication Date	Patent Family Member(s)	Publication Date
		US2018043114A1 WO2017205692A1	15 February 2018 (15-02-2018) 30 November 2017 (30-11-2017)
US2017156399A1	08 June 2017 (08-06-2017)	US10595562B2 AU2017316131A1 CA3027164A1 CN110573033A EP3503750A2 US2018295886A1 US2019230984A9 US2018333547A1 US2019328985A9 US2019133194A1 US2019133195A1 US2019134318A1 US2019275264A9 US2019150511A1 US2019150517A1 US2019150518A1 US2019159520A1 US2019159521A1 US2019217027A1 US2019231999A1 US2019247596A1 US2019261691A1 US2019335817A1 US2019343183A1 US2019343184A1 US2019343185A1 US2019364974A1 US2019373956A1 WO2018038765A2 WO2018038765A3 WO2019221989A1 WO2019231847A1	24 March 2020 (24-03-2020) 21 March 2019 (21-03-2019) 01 March 2018 (01-03-2018) 13 December 2019 (13-12-2019) 03 July 2019 (03-07-2019) 18 October 2018 (18-10-2018) 01 August 2019 (01-08-2019) 22 November 2018 (22-11-2018) 31 October 2019 (31-10-2019) 09 May 2019 (09-05-2019) 09 May 2019 (09-05-2019) 09 May 2019 (09-05-2019) 12 September 2019 (12-09-2019) 23 May 2019 (23-05-2019) 23 May 2019 (23-05-2019) 23 May 2019 (23-05-2019) 30 May 2019 (30-05-2019) 30 May 2019 (30-05-2019) 18 July 2019 (18-07-2019) 01 August 2019 (01-08-2019) 15 August 2019 (15-08-2019) 29 August 2019 (29-08-2019) 07 November 2019 (07-11-2019) 14 November 2019 (14-11-2019) 14 November 2019 (14-11-2019) 14 November 2019 (14-11-2019) 05 December 2019 (05-12-2019) 12 December 2019 (12-12-2019) 01 March 2018 (01-03-2018) 11 April 2019 (11-04-2019) 21 November 2019 (21-11-2019) 05 December 2019 (05-12-2019)
US6840116B2	11 January 2005 (11-01-2005)	US2004040386A1	04 March 2004 (04-03-2004)

INTERNATIONAL SEARCH REPORT

International application No.

PCT/CA2020/050292

G01N 15/10 (2006.01), *G01N 21/17* (2006.01), *G01N 21/51* (2006.01), *G01N 21/59* (2006.01),
G01N 25/08 (2006.01), *G06M 11/00* (2006.01), *G01F 1/36* (2006.01)