

(19)



(11)

EP 2 749 838 A1

(12)

EUROPEAN PATENT APPLICATION

(43) Date of publication:
02.07.2014 Bulletin 2014/27

(51) Int Cl.:
F42B 5/307^(2006.01) F42B 5/313^(2006.01)

(21) Application number: **14161688.8**

(22) Date of filing: **13.01.2012**

(84) Designated Contracting States:
AL AT BE BG CH CY CZ DE DK EE ES FI FR GB GR HR HU IE IS IT LI LT LU LV MC MK MT NL NO PL PT RO RS SE SI SK SM TR

(72) Inventors:
• **Padgett, Charles Orlando, FL Florida 32803 (US)**
• **Wiley, Sy Orlando, FL Florida 32828 (US)**

(30) Priority: **14.01.2011 US 201161433170 P**

(74) Representative: **Rapisardi, Mariacristina et al Ufficio Brevetti Rapisardi S.r.l. Via Serbelloni, 12 20122 Milano (IT)**

(62) Document number(s) of the earlier application(s) in accordance with Art. 76 EPC:
12702665.6 / 2 663 831

(71) Applicant: **PCP Ammunition Company LLC Orlando, FL 32809 (US)**

Remarks:
This application was filed on 26-03-2014 as a divisional application to the application mentioned under INID code 62.

(54) **High strength polymer-based cartridge casing for blank and subsonic ammunition**

(57) A high strength polymer-based cartridge casing (100) includes an upper component of polymer (200) having a first end (220) with a mouth (208), at least a wall between the first end and a second end (304) of the upper component opposite the first end, a sleeve (230) extending longitudinally and radially about the wall, and at least one of an overlap portion (222) and an underskirt portion extending from the wall near the second end. The lower component (300) is molded from a polymer and includes

at least one of a tapered portion (306) and an outer tapered portion that engages at least one of the overlap portion and the underskirt portions, respectively, to join the upper and the lower components. Further, the sleeve reduces a volume of a propellant chamber formed by the wall. The reduced volume of the propellant chamber permits only enough propellant to propel a bullet engaged in the cartridge casing at subsonic speeds.

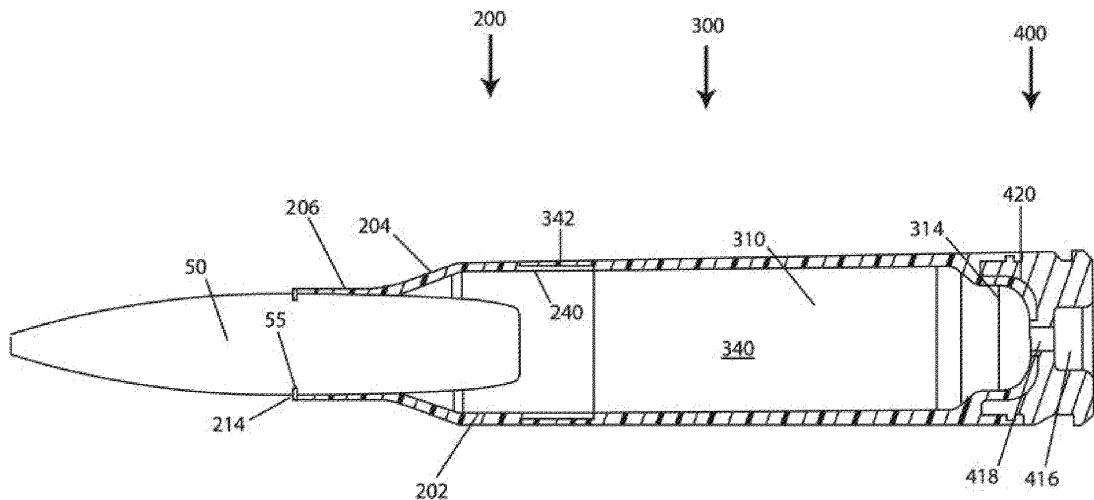

Fig. 12

EP 2 749 838 A1

Description

Cross-Reference to Related Applications

[0001] This application claims priority to U.S. Provisional Application Serial No. 61/433,170 filed January 14, 2011. The provisional application is incorporated herein by reference.

Technical Field

[0002] The present subject matter relates to techniques and equipment to make ammunition articles and, more particularly, to ammunition articles with plastic components such as cartridge casing bodies and bases for at least blank and subsonic ammunition.

Background

[0003] It is well known in the industry to manufacture bullets and corresponding cartridge cases from either brass or steel. Typically, industry design calls for materials that are strong enough to withstand extreme operating pressures and which can be formed into a cartridge case to hold the bullet, while simultaneously resist rupturing during the firing process.

[0004] Conventional ammunition typically includes four basic components, that is, the bullet, the cartridge case holding the bullet therein, a propellant used to push the bullet down the barrel at predetermined velocities, and a primer, which provides the spark needed to ignite the powder which sets the bullet in motion down the barrel.

[0005] The cartridge case is typically formed from brass and is configured to hold the bullet therein to create a predetermined resistance, which is known in the industry as bullet pull. The cartridge case is also designed to contain the propellant media as well as the primer.

[0006] However, brass is heavy, expensive, and potentially hazardous. For example, the weight of 0.50 caliber ammunition is about 60 pounds per box (200 cartridges plus links).

[0007] The bullet is configured to fit within an open end or mouth of the cartridge case and conventionally includes a groove (hereinafter referred to as a cannelure) formed in the mid section of the bullet to accept a crimping action imparted to the metallic cartridge case therein. When the crimped portion of the cartridge case holds the bullet by locking into the cannelure, a bullet pull value is provided representing a predetermined tension at which the cartridge case holds the bullet. The bullet pull value, in effect, assists imparting a regulated pressure and velocity to the bullet when the bullet leaves the cartridge case and travels down the barrel of a gun.

[0008] Furthermore, the bullet is typically manufactured from a soft material, such as, for example only, lead, wherein the bullet accepts the mouth of the cartridge being crimped to any portion of the bullet to hold the bullet

in place in the cartridge case, even though the cartridge case is crimped to the cannelure of the bullet

[0009] However, one drawback of this design is that the crimped neck does not release from around the bullet evenly when fired. This leads to uncertain performance from round to round. Pressures can build up unevenly and alter the accuracy of the bullet.

[0010] The propellant is typically a solid chemical compound in powder form commonly referred to as smokeless powder. Propellants are selected such that when confined within the cartridge case, the propellant burns at a known and predictably rapid rate to produce the desired expanding gases. As discussed above, the expanding gases of the propellant provide the energy force that launches the bullet from the grasp of the cartridge case and propels the bullet down the barrel of the gun at a known and relatively high velocity.

[0011] The primer is the smallest of the four basic components used to form conventional ammunition. As discussed above, primers provide the spark needed to ignite the powder that sets the bullet in motion down the barrel. The primer includes a relatively small metal cup containing a priming mixture, foil paper, and relatively small metal post, commonly referred to as an anvil.

[0012] When a firing pin of a gun or firearm strikes a casing of the primer, the anvil is crushed to ignite the priming mixture contained in the metal cup of the primer. Typically, the primer mixture is an explosive lead styphnate blended with non-corrosive fuels and oxidizers which burns through a flash hole formed in the rear area of the cartridge case and ignites the propellant stored in the cartridge case. In addition to igniting the propellant, the primer produces an initial pressure to support the burning propellant and seals the rear of the cartridge case to prevent high-pressure gases from escaping rearward. It should be noted that it is well known in the industry to manufacture primers in several different sizes and from different mixtures, each of which affects ignition differently.

[0013] The cartridge case, which is typically metallic, acts as a payload delivery vessel and can have several body shapes and head configurations, depending on the caliber of the ammunition. Despite the different body shapes and head configurations, all cartridge cases have a feature used to guide the cartridge case, with a bullet held therein, into the chamber of the gun or firearm.

[0014] The primary objective of the cartridge case is to hold the bullet, primer, and propellant therein until the gun is fired. Upon firing of the gun, the cartridge case seals the chamber to prevent the hot gases from escaping the chamber in a rearward direction and harming the shooter. The empty cartridge case is extracted manually or with the assistance of gas or recoil from the chamber once the gun is fired.

[0015] As shown in FIG. 1A, a bottleneck cartridge case 10 has a body 11 formed with a shoulder 12 that tapers into a neck 13 having a mouth at a first end. A primer holding chamber 15 is formed at a second end of

the body opposite the first end A divider 16 separates a main cartridge case holding chamber 17, which contains a propellant, from the primer holding chamber 15, which communicate with each other via a flash hole channel 18 formed in the web area 16. An exterior circumferential region of the rear end of the cartridge case includes an extraction groove 19a and a rim 19b.

[0016] Prior art patents in this area include U.S. Patent No. 4,147,107 to Ringdal, U.S. Patent No. 6,845,716 to Hussein et al., U.S. Patent No. 7,213,519 to Wiley et al., and U. S. Patent No. 7,610,858 to Chung. The four patents are directed to an ammunition cartridge suitable for rifles or guns and including a cartridge case made of at least a plastics material. However, each have their own drawbacks.

[0017] Further, the use of brass cartridges for blank or subsonic ammunition can be problematic. To reduce the velocity of the bullet exiting the cartridge, typically less propellant is used in comparison to when the bullet is traveling at its top velocity. However, the same size cartridge needs to be used so the bullet can be fired from a standard firearm. An empty space is left inside a blank or subsonic cartridge where the propellant would normally reside. To compensate, wadding (typically cotton) can be packed into the space normally filled by the propellant. This wadding can cause problems with the use of the round, including jamming the firearm and fouling silencers and/or suppressors attached to the firearm.

[0018] Hence, a need exists for a polymer casing that can perform as well as or better than the brass alternative. A further improvement are polymer casings that are capable of production in a more conventional and cost effective manner, i.e. by using standard loading presses. Additionally, the cartridge can provide increased performance for blank and subsonic rounds.

Summary

[0019] The teachings herein alleviate one or more of the above noted problems with the strength and formation of polymer based cartridges.

[0020] Thus, a high strength polymer-based cartridge casing can include an upper component, molded from a polymer, and having a first end with a mouth, at least a wall between the first end and a second end of the upper component opposite the first end, a sleeve extending longitudinally and radially about the wall, and at least one of an overlap portion and an underskirt portion extending from the wall near the second end. The lower component is molded from a polymer and includes at least one of a tapered portion and an outer tapered portion that engages at least one of the overlap portion and the underskirt portions, respectively, to join the upper and the lower components. Further, the sleeve reduces a volume of a propellant chamber formed by the wall. The reduced volume of the propellant chamber permits only enough propellant to propel a bullet engaged in the cartridge casing at subsonic speeds or less, if it is a blank cartridge.

[0021] Alternately, the upper component of the high strength polymer-based cartridge casing can further include an extension engaged at the mouth and a cap engaged to an end of the extension opposite the mouth. In an example, the cap elastically deforms when the cartridge is fired.

[0022] As a result, a light weight, high strength cartridge case can be formed using standard brass cartridge loading equipment. As noted below, the present invention can be adapted to any type of cartridge, caliber, powder load, or primer. Calibers can range at least between .22 and 30 mm and accept any type of bullet that can be loaded in a typical brass cartridge.

[0023] Further advantages can be gained in both blank and subsonic ammunition due to the removal of wadding and the shrinking of the volume of powder based on a reduced volume in the cartridge.

[0024] The polymer used can be of any known polymer and additives, but the present invention uses a nylon polymer with glass fibers. Further, the portion of the cartridge that engages the extractor of the firearm can be made from heat strengthened steel for normal loads and can be a continuous molded polymer piece of the lower component for either subsonic or blank ammunition.

[0025] Additional advantages and novel features will be set forth in part in the description which follows, and in part will become apparent to those skilled in the art upon examination of the following and the accompanying drawings or may be learned by production or operation of the examples. The advantages of the present teachings may be realized and attained by practice or use of various aspects of the methodologies, instrumentalities and combinations set forth in the detailed examples discussed below.

Brief Description of the Drawings

[0026] The drawing figures depict one or more implementations in accord with the present teachings, by way of example only, not by way of limitation. In the figures, like reference numerals refer to the same or similar elements.

FIG. 1A is a cross sectional view of a conventional bottleneck cartridge case;

FIG. 1B is a side view of a conventional bullet;

FIG. 2 is a side perspective view of the outside of cartridge case of the present invention;

FIG. 3 is a longitudinal cross-section of the upper component of the cartridge;

FIG. 4 is a bottom, side, perspective, radial cross-section of the upper and lower components of the cartridge;

FIG. 5 is an end view of the upper component without the lower component and insert;

FIG. 6 is a side view of the lower component without the upper component and insert;

FIG. 7 is a bottom front perspective view of the lower

component of FIG. 6;
 FIG. 8 is a longitudinal cross-section view of the lower component of FIG. 6;
 FIG. 9 is a side view of the insert without the upper and lower components;
 FIG. 10 is a bottom front perspective view of the insert of FIG. 8;
 FIG. 11 is a longitudinal cross-section view of the insert of FIG. 8;
 FIG. 12 is a longitudinal cross-section view of an example of a cartridge case;
 FIG. 13 is a top, side, perspective view of the upper component of the example;
 FIG. 14 is a top, side perspective view of an example of an upper component of a subsonic cartridge;
 FIG. 15 is a top, side perspective view of an upper component for a blank cartridge;
 FIG. 16 is a longitudinal cross-section view of an example of a straight wall cartridge case; and
 FIG. 17 is a longitudinal cross-section view of the cartridge case of FIG. 2.

Detailed Description

[0027] In the following detailed description, numerous specific details are set forth by way of examples in order to provide a thorough understanding of the relevant teachings. However, it should be apparent to those skilled in the art that the present teachings may be practiced without such details. In other instances, well known methods, procedures, components, and/or circuitry have been described at a relatively high-level, without detail, in order to avoid unnecessarily obscuring aspects of the present teachings.

[0028] The present invention provides a cartridge case body strong enough to withstand gas pressures that equal or surpass the strength of brass cartridge cases under certain conditions, e.g. for both storage and handling

[0029] Reference now is made in detail to the examples illustrated in the accompanying drawings and discussed below. FIG. 2 illustrates an example of a cartridge case 100. The cartridge case 100 includes an upper component 200, a lower component 300, and an insert 400. In this example, the upper component 200 and the lower component 300 are made of a polymer, while insert 400 is made from a metal, an alloy of metals, or an alloy of a metal and a non-metal. Regardless of materials, the outer dimensions of the cartridge case 100 are within the acceptable tolerances for whatever caliber firearm it will be loaded into.

[0030] The polymer used is lighter than brass. A glass-filled high impact polymer can be used where the glass content is between 0%-50%, preferably between 5% and 50%. In another example the glass content can be 10%. An example of a high impact polymer without the glass content is BASF's Capron[®] BU501. The insert 400 can be made of steel, and, in an example, heat treated carbon

steel, 4140. The 4140 steel is further heat treated to a Rockwell "C" scale ("RC") hardness of about 20 to about 50. However, any carbon steel with similar properties, other metals, metal alloys or metal/non-metal alloys can be used to form the insert Heat treating a lower cost steel alloy to improve its strength is a point of distinction from the prior art, which have typically opted for more expensive alloys to deal with the strength and ductility needed for a cartridge casing application.

[0031] In an example, the combination of the upper component 200 and the lower component 300 are made of 10% glass-filled high impact polymer combined with the insert 400 made of heat treated 4140 steel results in a cartridge that is approximately 50% lighter than a brass formed counterpart. This weight savings in the unloaded cartridge produces a loaded cartridge of between 25%-30% lighter than the loaded brass cartridge depending on the load used, i.e. which bullet, how much powder, and type of powder used

[0032] The upper component 200 includes a body 202 which transitions into a shoulder 204 that tapers into a neck 206 having a mouth 208 at a first end 210. The upper component 200 joins the lower component 300 at an opposite, second end 212. The lower component 300 joins the upper component 200 at a lower component first end 302 (see FIG. 6). The upper 200 and lower 300 components are adhered by an ultraviolet (UV) light or heat cured resin, a spin weld, a laser weld or an ultrasonic weld.

[0033] At a second end 304 of the lower component 300, the lower component is joined to the insert 400. In one example, the upper component 200 and the lower component 300 are molded in separate molds. When the lower component 300 is molded, it is molded over the insert 400. This is a partial molding over, since the lower component 300 does not completely cover the insert 400.

[0034] A back end 402 of the insert 400 is also the rear end of the casing 100. The insert 400 is formed with an extraction groove 404 and a rim 406. The groove 404 and rim 406 are dimensioned to the specific size as dictated by the caliber of the ammunition. The insert 400 can be formed by turning down bar stock to the specific dimensions or can be cold formed

[0035] Turning now to FIG. 3, a cross-section of the upper component 200 is illustrated. Because of the nature of the polymer, and the design of the neck 206 and mouth 208, the neck 206 expands uniformly under the gas pressures formed during firing. This concentric expansion provides a smoother release of the projectile into the barrel of the firearm. The smoother release allows for a more stable flight of the projectile, providing greater accuracy and distance with the same amount of powder.

[0036] Moving toward the second end 212 of the upper component 200, as the neck 206 transitions into the shoulder 204, a sleeve 230 begins. The sleeve 230, in this example, extends approximately to the second end 212. The sleeve 230 can be an additional thickness to a wall 218 as is normally required for a standard cartridge,

or a separately manufactured and adhered to the wall 218. The sleeve 230 provides additional strength relative to the wall 218 of the body 202 alone. This strengthening, which is in the lateral direction, reduces bending of the upper component 200 of the cartridge case 100. The sleeve 230 helps to keep the cartridge 100 as concentric as possible, and as noted above, concentricity is a key to accuracy.

[0037] The case wall 218 can have a thickness T , and the sleeve 230 can have a thickness $T+$, as illustrated in FIG. 4. Thus, the total thickness of the cartridge at the point where there is the wall 218 and sleeve 230 is the sum of T and $T+$.

[0038] The upper portion 220 of the sleeve 230 can begin in or near the neck 206 and extend over the shoulder 204. In one example, the upper portion 220 of the sleeve 230 ends against a bullet 50 (see FIG. 1B) providing additional material, and thus strength, to help retain and align the bullet 50. This thickened upper portion 220 can act like an extension of the neck 206 farther down into the shoulder. The upper portion 220 is an advantage over a brass cartridge, since brass cannot be formed in this way. Thus, the upper portion 220 can act to sit and secure the bullet in the same place in the cartridge every time.

[0039] The sleeve 230, in the illustrated example of FIGs. 3, 4 and 5, extends almost the entire length of the body 202. The sleeve 230 stops at an overlap portion 222 of the upper component 200. The overlap portion 222 is the portion of the upper component 200 that engages the lower component 300. The overlap portion 222 has a thinner wall thickness t , or a second thickness, at the second end 212 than the thickness T of the wall 218 (or T and $T+$) before the overlap portion 222. The second thickness t tapers toward the outside of the upper component 200 so an outer diameter 224 of the wall 218 remains constant while an inner diameter 226 of the wall 218 increases. This allows certain examples of cartridge 100 to maintain a constant outer diameter from below the shoulder 204 to the insert 400. The bottom end 228 of the sleeve 230 is approximately squared off to provide a square shoulder to keep the upper 200 and lower 300 components concentric during assembly.

[0040] FIGs. 6-8 illustrate that the lower component 300 has a tapered portion 306 starting at the lower component first end 302 and ending at a collar 308. The slope of the tapered portion 306 approximately matches the slope of the overlap portion 222 so the two can slide over each other to engage the upper 200 and lower 300 components. The tapered portion 306 ends in a flat seat 307. The seat 307 can have a thickness T_s which is about equal to the thickness of the wall and/or sleeve. This allows the bottom end 228 of the sleeve to sit on the seat 307 when the upper 200 and lower 300 components engage. This prevents the bottom end 228 of the sleeve 230 from being exposed. This could allow the gases to exert pressure on the bottom end 228 that can separate the upper 200 from the lower 300 component.

[0041] A width of the collar 308 matches the second thickness t , so that the outer diameter of the cartridge 100 remains constant past the transition point between the upper 200 and lower 300 components. Further, a thickness of the tapered portion 306 is such that at any point the sum of it with the thickness of the overlap portion 222 is approximately equal to the thickness T of the wall 218 or the thicknesses of the wall 218 and sleeve 230 (T and $T+$). As noted above, the tapered portion 306 and the overlap portion 222 are bonded together to join the upper 200 and lower 300 components.

[0042] An inner wall 310 of the lower component 300 can be formed straight. In the illustrated example in FIG. 8, the inner wall 310 forms a bowl shape with a hole 312 at the bottom. The hole 312 is formed as a function of the interface between the lower component 300 and the insert 400, and its formation is discussed below. As the inner wall 310 slopes inward to form the bowl shape, it forks and forms an inner bowl 314 and an outer sheath 316. The gap 318 that is formed between the inner bowl 314 and the outer sheath 316 is the space where a portion of the insert 400 engages the lower component 300. As noted above, in one example, the lower component 300 is molded over a portion of the insert 400 to join the two parts.

[0043] Turning now to an example of the insert 400, as illustrated in FIG. 9, it includes an overmolded area 408, where the outer sheath 316 engages the insert 400 in the gap 318. The overmolded area 408 has one or more ridges 410. The ridges 410 allow the polymer from the outer sheath 316, during molding, to form bands 320 (see, FIG. 8) in the gap 318. The combination of the ridges 410 and bands 320 aid in resisting separation between the insert 400 and the lower component 300. The resistance is most important during the extraction of the cartridge from the firearm by an extractor (not illustrated).

[0044] The overmolded area 408 also includes one or more keys 412. The keys 412 are flat surfaces on the ridges 410. These keys 412 prevent the insert 400 and the lower portion 300 from rotating in relation to one another, i.e. the insert 400 twisting around in the lower portion 300.

[0045] Below the overmolded area 408, toward the back end 402, is a self reinforced area 414. This portion extends to the back end 402 of the insert 400 and includes the extraction groove 404 and rim 406. The self reinforced area 414 must, solely by the strength of its materials, withstand the forces exerted by the pressures generated by the gasses when firing the bullet and the forces generated by the extractor. In the present example, the self reinforced area 414 withstands these forces because it is made of a heat treated metal or a metal/non-metal alloy.

[0046] FIGs. 10 and 11 illustrate an example of the inside of the insert 400. Open along a portion of the back end 402 and continuing partially toward the overmolded area 408 is a primer pocket 416. The primer pocket 416 is dimensioned according to the standards for caliber of

the cartridge case and intended use. A primer (not illustrated) is seated in the primer pocket 416, and, as described above, when stricken causes an explosive force that ignites the powder (not illustrated) present in the upper 200 and lower 300 components.

[0047] Forward of the primer pocket 416 is a flash hole 418. Again, the flash hole 418 is dimensioned according to the standards for the caliber of the cartridge case and intended use. The flash hole 418 allows the explosive force of the primer, seated in the primer pocket 418, to communicate with the upper 200 and lower 300 components.

[0048] Forward of the primer pocket 416 and inside the overmolded area 408 is basin 420. The basin 420 is adjacent to and outside of the inner bowl 314 of the lower component 300. The basin 420 is bowl shaped, wherein the walls curve inwards toward the bottom. The bottom of the basin 420 is interrupted by a ring 422. The ring 422 surrounds the flash hole 418 and extends into the basin 420. It is the presence of the ring 422 that forms the hole 312 in the inner bowl 314 of the lower component 300.

[0049] In another example of a cartridge case 120, the sizes of the upper 200 and lower 300 components can be altered FIG. 12 illustrates a "small upper" embodiment with a bullet 50 in the mouth 208 of the cartridge 120. The features of the upper 200 and lower 300 component are almost identical to the example discussed above, and the insert 400 can be identical. FIG. 12 also illustrates the engagement between a lip 214 and the cannellure 55. The lip 214 is a section of the neck 206 approximate to the mouth 208 that has a thicker cross section or, said differently, a portion having a smaller inner diameter than the remainder of the neck 206. In this example, the lip 214 is square or rectangular shaped, no angles or curves in the longitudinal direction. Note, in other examples, the upper component 200 is not formed with a lip 214. When present, the lip 214 engages the cannellure 55 formed along an outer circumferential surface of the bullet 50 when it is fitted into the mouth 208 of the cartridge casing 100.

[0050] FIG. 13 shows that the neck 206 and the shoulder 204 are formed similar, but in this example, the body 202 is much shorter. Further, instead of an overlap portion 222, there is an underskirt portion 240 that starts very close to the shoulder 204. The underskirt portion 240 tapers to the inside of the cartridge when it engages the lower component 300.

[0051] The lower component 300 in this further example, is now much longer and comprises most of the propellant chamber 340. The tapered portion is now replaced with an outer tapered portion 342. The outer tapered portion 342 slides over the underskirt portion 240 so the two can be joined together as noted above. The thickness of the underskirt portion 240 and the outer tapered portion 342 is approximate to the wall thickness or wall thickness and sleeve thickness.

[0052] The inner wall 310 is now substantially longer, can include a sleeve, but still ends in the inner bowl 314.

The engagement between the second end 304 of the lower component 300 and the insert 400 remains the same. Note that either the "small upper" or "long upper" can be used to form blank or subsonic ammunition. The walls are made thicker with the sleeve, shrinking the size of the propellant chamber 340. Less powder can be used, but the powder is packed similarly as tight as it is for a live round because of the smaller chamber 340. This can prevent the Secondary Explosive Effect (SEE) (below). A thick wall design for a subsonic cartridge 140 is illustrated in FIG. 14.

[0053] Illustrated is a large upper component 200 having a thicker overlap 222 portion, with a thickness $t+$ and an integral thickening of the wall, and/or a sleeve 230 with a thickness $T+$, as disclosed above. The total thickness of the wall 218 can be the sum of $T+$ and $t+$. The sleeve 230 can run the length of the upper component 200 from the mouth 208 to the start of the overlap portion 222. The lower component 300 of a subsonic cartridge 140 can be thickened as well. The subsonic cartridge 140 can be made with the insert 400, or the lower component 300 can be molded in one piece from polymer with the features of the insert 400. For example, the flash hole 418, primer pocket 416, groove 404 and rim 406. Alternately, the insert can also be high-strength polymer instead of the metal alloys discussed above. In this example, the lower component and the insert can be formed as one piece, and the upper component 200 can be placed on top.

[0054] As illustrated in FIG. 15, for a blank cartridge 150, the upper component 200 can be made differently. For the blank cartridge 150, an extension 242 can be molded to extend from the neck 206. The extension 242 has a star-shaped cap 244 to seal off the cartridge. The cap 244 is formed partially of radially spaced fingers 246 that deform outwards during firing. Thus, the mouth 208 is molded partially shut to contain a majority of the pressures and expand open and outwards. The fingers 246 are designed, in one example, to be bend elastically and are not frangible. The object is to contain the majority of the pressures and expel anything that can act as a projectile out the barrel of the firearm.

[0055] When the blank cartridge 150 is formed with the "small upper" component 200 with the cap 244. The lower component 300 can be filled with the powder and the small upper component can act as a cap to the cartridge, sealing in the powder.

[0056] Note that the above examples illustrate a bottleneck cartridge. Many of the features above can be used with any cartridge style, including straight wall cartridges used in pistols. FIG. 16 illustrates an example of a straight wall cartridge 500. The straight wall cartridge 500 is a one-piece design of all polymer. The cartridge 500 has a body 502 and a mouth 508 at a first end 510. The walls 518 of the cartridge casing can also have a sleeve 530 along a majority of its length.

[0057] The sleeve 230, 530 is dimensioned and shaped pursuant to the requirements of each cartridge

based on blank or subsonic and the particular caliber. To that end, the sleeve 530 begins set back from the first end 510 based on the depth the rear of the bullet sits in the cartridge. Further, in this example, as the walls transition into a lower bowl 514, the sleeve 530 may extend into the bowl. This aids in the strength of a back end 512 of the cartridge 500, since this example lacks a hardened metal insert.

[0058] The lower bowl 514 curves downward toward a flash hole 517 which then opens to a primer pocket 519. Both are similar to the features described above. Further, the back end is molded to form a rim 506.

[0059] Turning now to an example of a fully formed cartridge case 100, FIG. 17 illustrates a cross-section of all three elements engaged together to illustrate how they interface with each other. The specific outer dimensions of the three elements and certain inner dimensions (e.g. mouth 208, lip 214, flash hole 418, and primer pocket 416) are dictated by the caliber and type of the firearm and type of ammunition. The cartridge casing 100 of the present invention is designed to be used for any and all types of firearms and calibers, including pistols, rifles, manual, semi-automatic, and automatic firearms.

[0060] An exemplary construction of the upper component 200 also aids in withstanding the pressures generated. As noted above, the sleeve 230 increases the strength of the wall 218 of the upper component 200. In the present example, the upper component 200 accounts for anywhere from 70% to 90% of the length of the cartridge casing 100.

[0061] The polymer construction of the cartridge case also provides a feature of reduced friction between the cartridge and chamber of the firearm. Reduced friction leads to reduced wear on the chamber, further extending its service life.

[0062] Subsonic ammunition can be manufactured using the above illustrated examples. Subsonic ammunition is designed to keep the bullet from breaking the speed of sound (approximately 340 m/s at sea level or less than 1,100 fps). Breaking the speed of sound results in the loud "crack" of a sonic boom, thus subsonic ammunition is much quieter than is standard counterpart. Typical subsonic ammunition uses less powder, to produce less energy, in the same cartridge case as standard ammunition. The remaining space is packed with wadding/filler to keep the powder near the flash hole so it can be ignited by the primer. As noted above, increasing the wall thickness eliminates the need for wadding. In one example, while a brass cartridge wall can be 0.0389" thick, the polymer wall and sleeve can have a total thickness of 0.0879" for the identical caliber.

[0063] The reduced capacity allows for a more efficient ignition of the powder and a higher load density with less powder. Low load density (roughly below 30-40%) is one of the main contributors to the Secondary Explosive Effect (SEE). SEE can destroy the strongest rifle action and it can happen on the first shot or the tenth. SEE is the result of slow or incomplete ignition of small amounts of

smokeless powder. The powder smolders and releases explosive gases which, when finally ignited, detonate in a high order explosion. The better sealing effect is also important here because standard brass does not seal the chamber well at the lower pressures created during subsonic shooting.

[0064] While the foregoing has described what are considered to be the best mode and/or other examples, it is understood that various modifications may be made therein and that the subject matter disclosed herein may be implemented in various forms and examples, and that the teachings may be applied in numerous applications, only some of which have been described herein. It is intended by the following claims to claim any and all applications, modifications and variations that fall within the true scope of the present teachings.

Claims

1. A high strength polymer-based cartridge casing for at least one of blank or subsonic ammunition comprising:
 - an upper component, molded from a polymer, comprising:
 - a first end having a mouth; and
 - at least a wall between the first end and a second end of the upper component opposite the first end;
 - a lower component, molded from a polymer, joined with the upper component, and having a lower wall;
 - an insert joined to the lower component;
 - a polymer sleeve extending longitudinally, radially, and in contact with at least one of the wall and the lower wall;
 - wherein the polymer sleeve has a uniform thickness and reduces a volume of a propellant chamber formed by at least one of the wall and the lower wall.
2. The high strength polymer-based cartridge casing of claim 1, wherein the insert is made from a metal, an alloy of metals, or an alloy of a metal and a non-metal
3. The high strength polymer-based cartridge casing of claim 1, wherein an internal volume formed by the polymer sleeve between the mouth and the insert is unobstructed.
4. The high strength polymer-based cartridge casing of claim 1, wherein the sleeve is integral with the at least one of the wall and the lower wall.

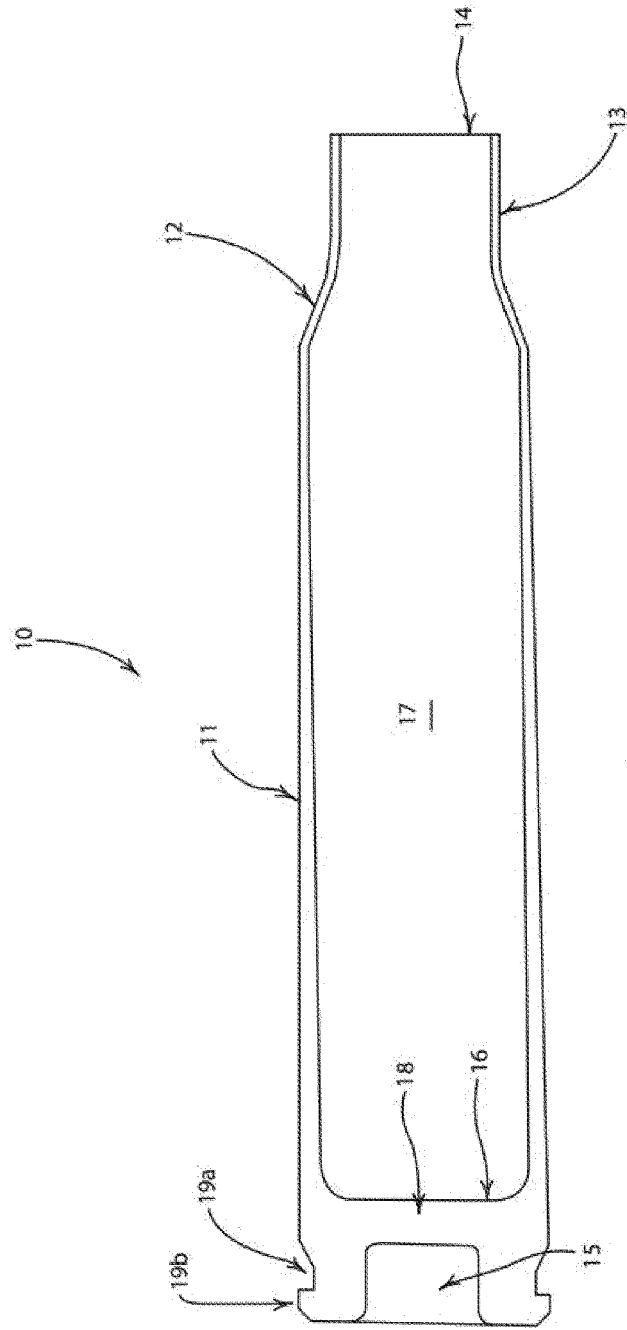

Fig. 1A
Prior Art

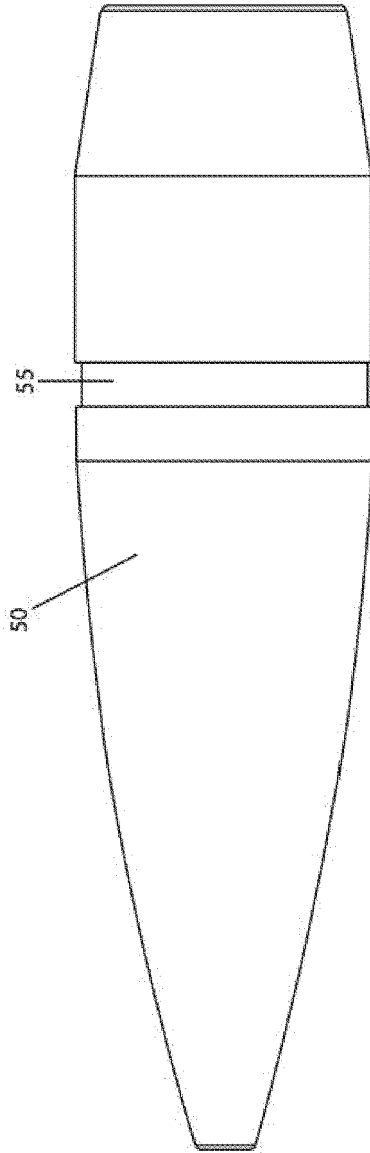

Fig. 1B
Prior Art

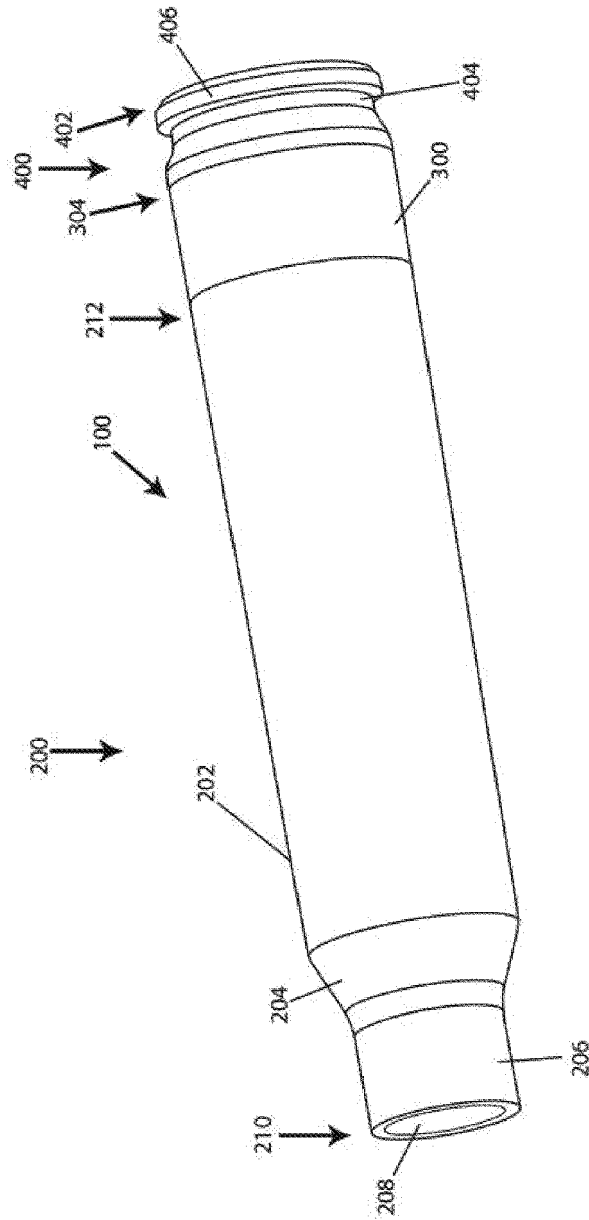

Fig. 2

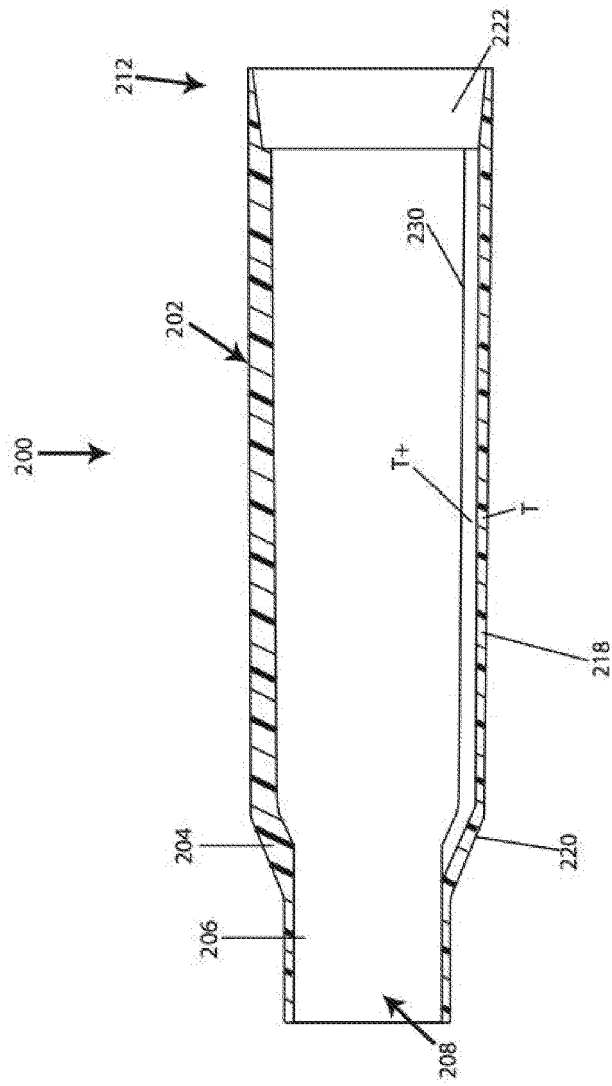

Fig.3

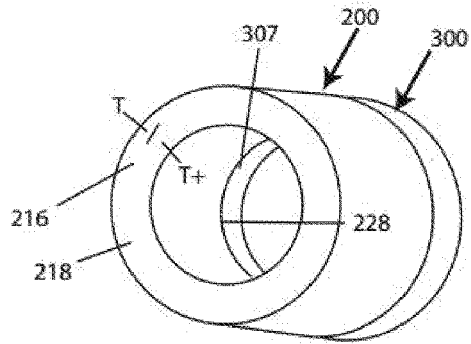
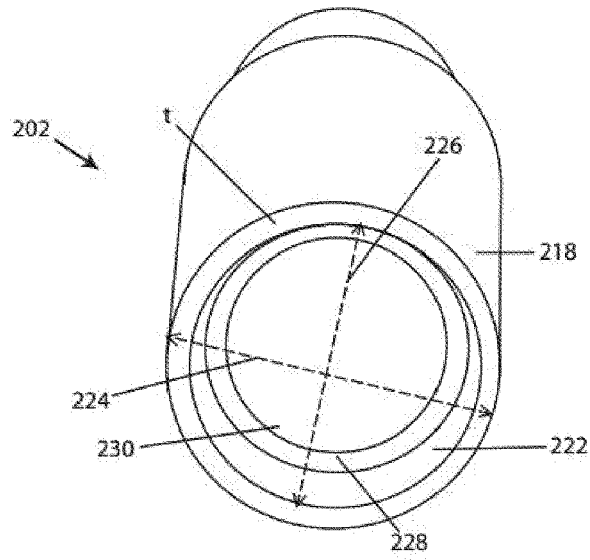
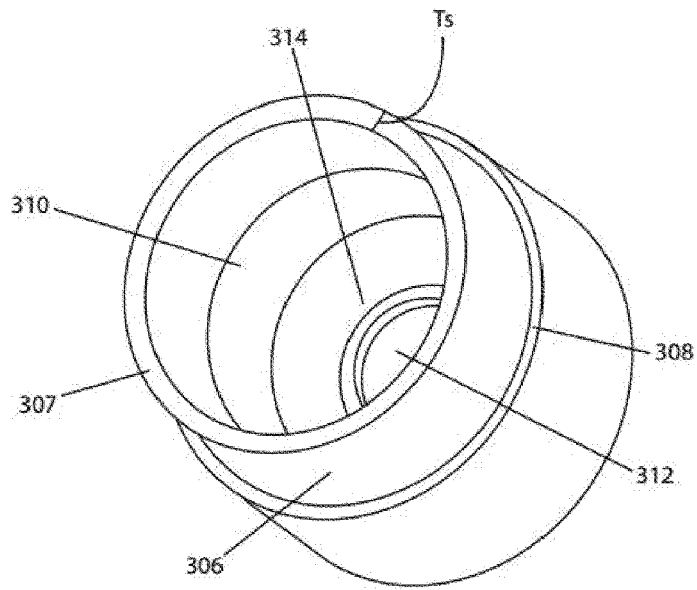
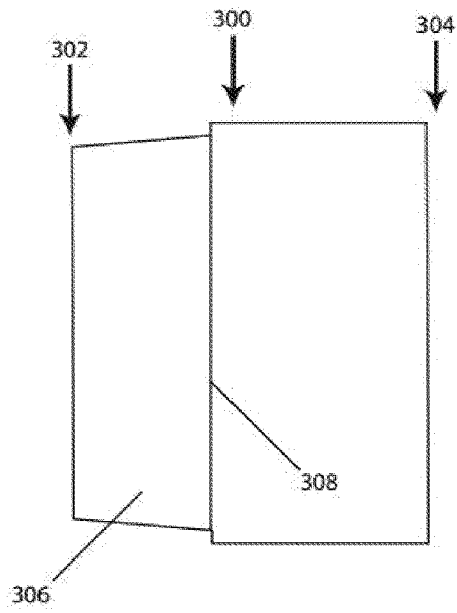

Fig. 4

Fig. 5





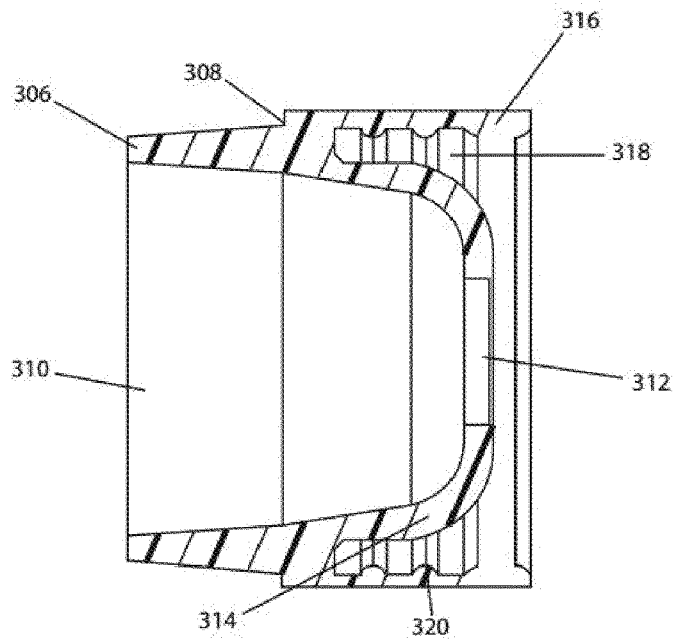

Fig. 8

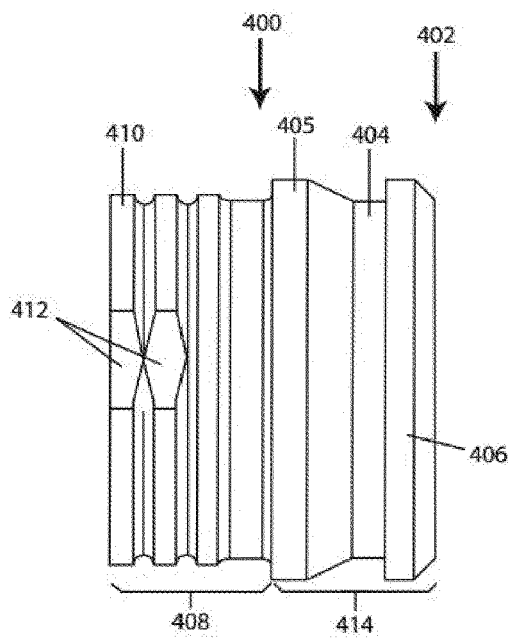

Fig. 9

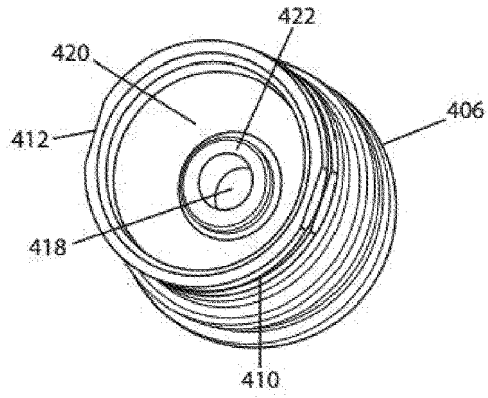

Fig. 10

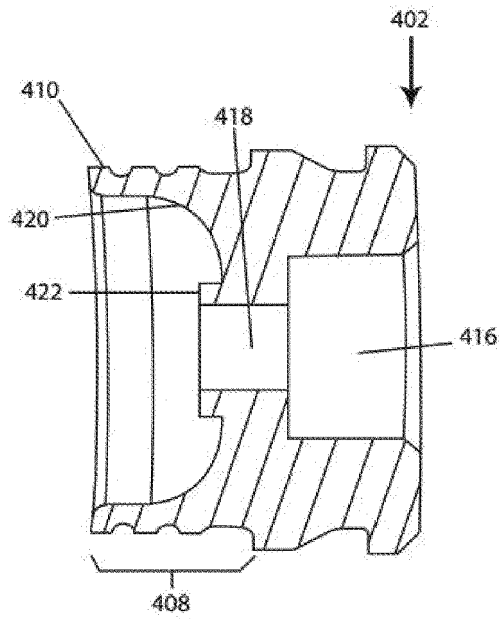

Fig. 11

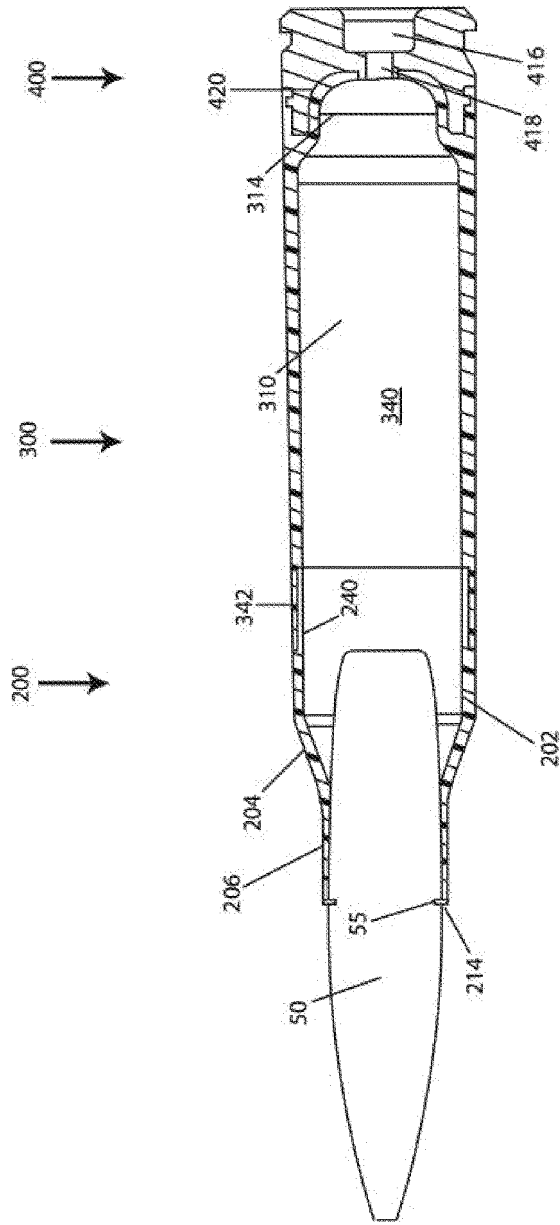

Fig. 12

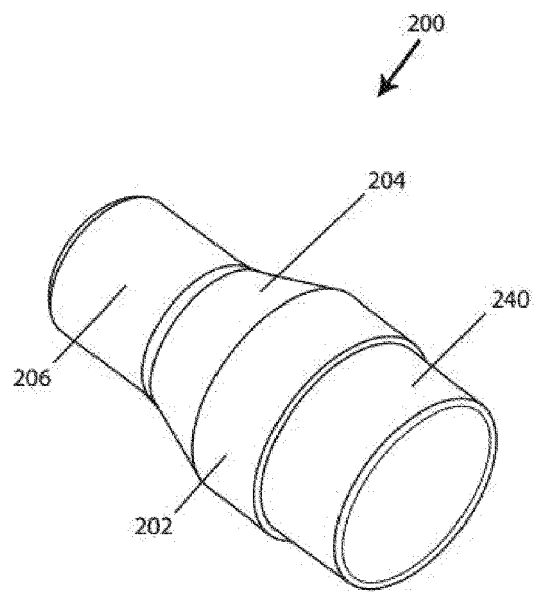

Fig. 13

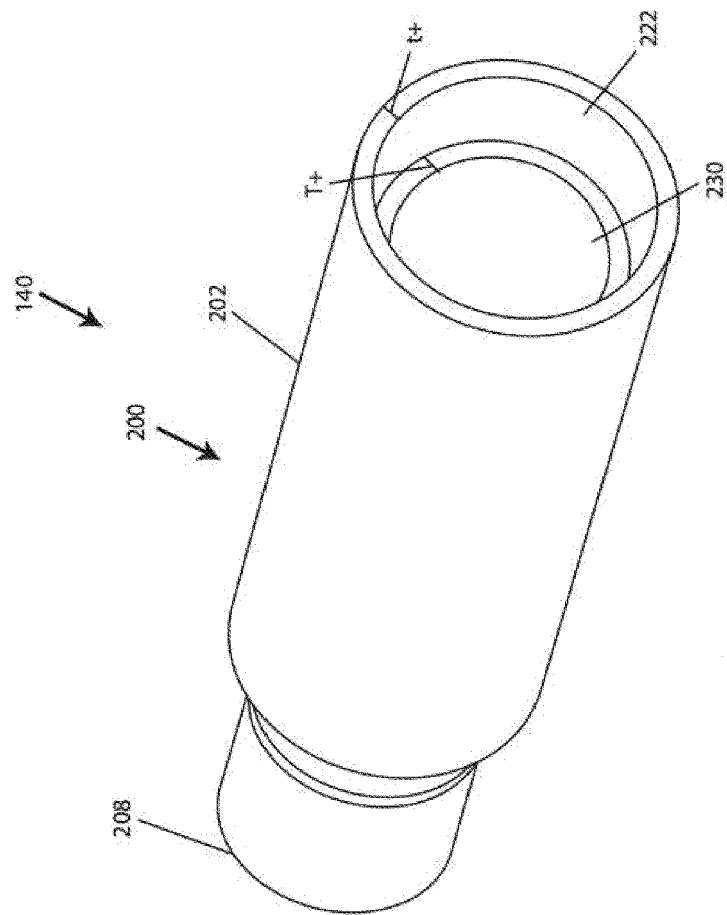

Fig. 14

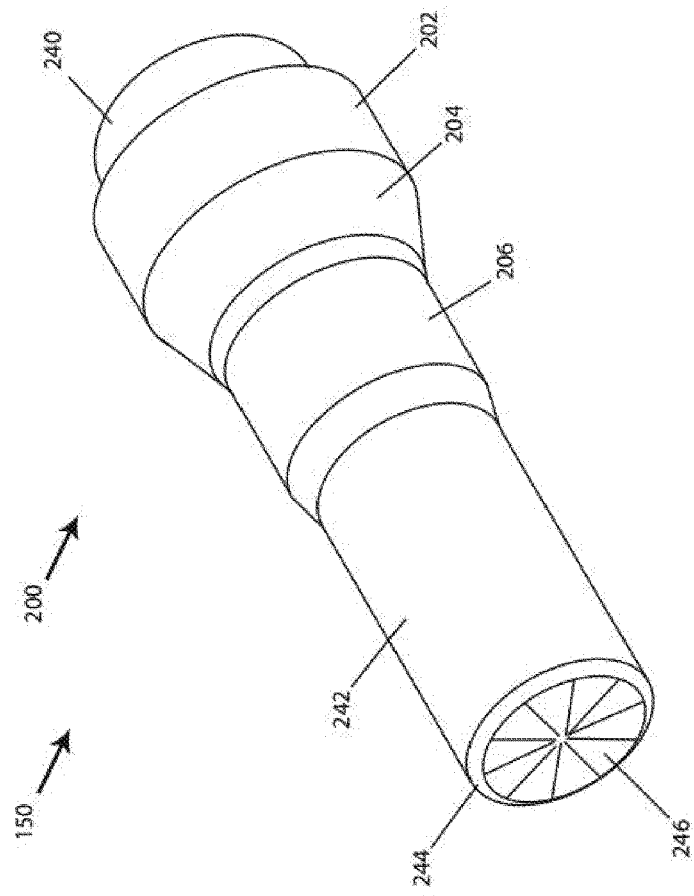

Fig. 15

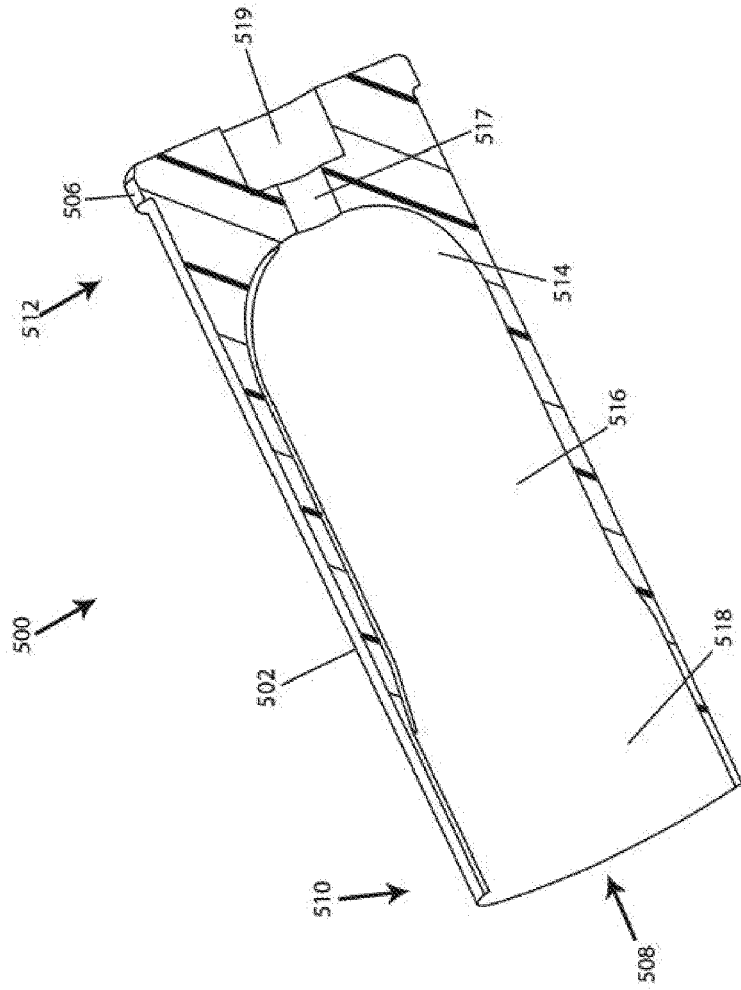

Fig. 16

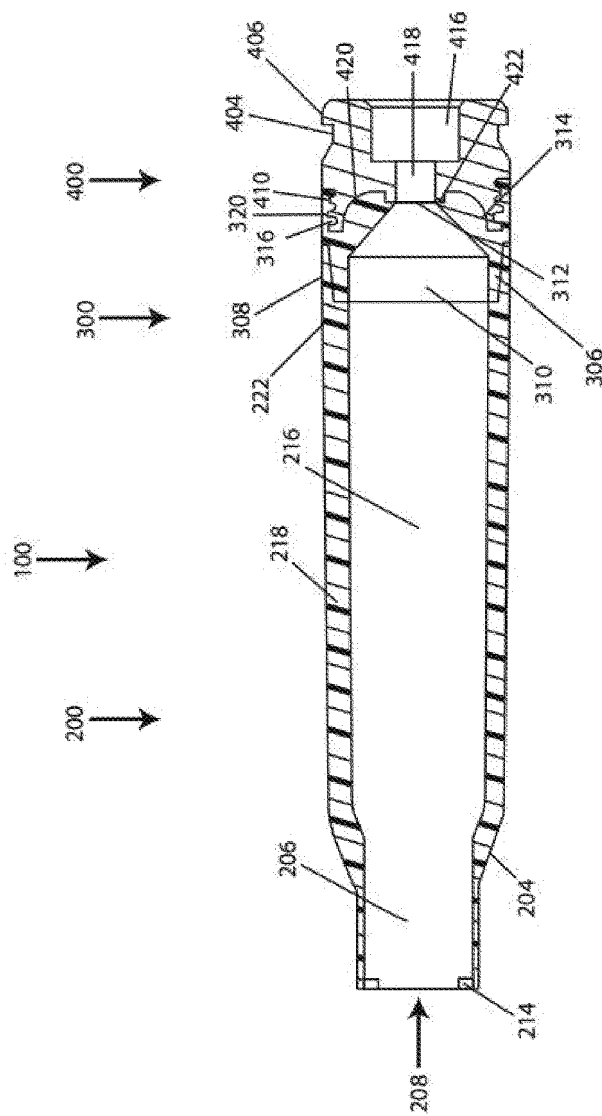

Fig. 17



EUROPEAN SEARCH REPORT

Application Number
EP 14 16 1688

5

10

15

20

25

30

35

40

45

50

55

DOCUMENTS CONSIDERED TO BE RELEVANT			
Category	Citation of document with indication, where appropriate, of relevant passages	Relevant to claim	CLASSIFICATION OF THE APPLICATION (IPC)
X	US 7 610 858 B2 (CHUNG SENGSHIU [US]) 3 November 2009 (2009-11-03) * abstract * * column 8, line 17 - line 26 * * column 10, line 9 - line 25 * * figures * -----	1-4	INV. F42B5/307 F42B5/313
X	US 7 213 519 B2 (WILEY SY [US] ET AL) 8 May 2007 (2007-05-08) * abstract * * column 11, line 11 - line 55; figures 13a-15c * * figures * -----	1,4	
X	DE 11 13 880 B (DYNAMIT NOBEL AG) 14 September 1961 (1961-09-14) * the whole document * -----	1-4	
A	EP 0 444 545 A1 (STEYR DAIMLER PUCH AG [AT]) 4 September 1991 (1991-09-04) * Rohrstück = sleeve; the whole document * -----	1-4	TECHNICAL FIELDS SEARCHED (IPC)
A	DE 33 44 369 A1 (FEISTEL PYROTECH FAB [DE]) 20 June 1985 (1985-06-20) * abstract * * figures * -----	1-4	F42B
The present search report has been drawn up for all claims			
Place of search The Hague		Date of completion of the search 7 May 2014	Examiner Vermander, Wim
CATEGORY OF CITED DOCUMENTS X : particularly relevant if taken alone Y : particularly relevant if combined with another document of the same category A : technological background O : non-written disclosure P : intermediate document		T : theory or principle underlying the invention E : earlier patent document, but published on, or after the filing date D : document cited in the application L : document cited for other reasons & : member of the same patent family, corresponding document	

EPO FORM 1503 03-82 (P04001)

**ANNEX TO THE EUROPEAN SEARCH REPORT
ON EUROPEAN PATENT APPLICATION NO.**

EP 14 16 1688

5

This annex lists the patent family members relating to the patent documents cited in the above-mentioned European search report. The members are as contained in the European Patent Office EDP file on The European Patent Office is in no way liable for these particulars which are merely given for the purpose of information.

07-05-2014

10

Patent document cited in search report	Publication date	Patent family member(s)	Publication date	
US 7610858	B2	03-11-2009	US 2007261587 A1 WO 2008051256 A2	15-11-2007 02-05-2008
US 7213519	B2	08-05-2007	EP 1946037 A2 US 2006075919 A1 WO 2008048224 A2	23-07-2008 13-04-2006 24-04-2008
DE 1113880	B	14-09-1961	NONE	
EP 0444545	A1	04-09-1991	AT 393163 B EP 0444545 A1 US 5063853 A	26-08-1991 04-09-1991 12-11-1991
DE 3344369	A1	20-06-1985	NONE	

15

20

25

30

35

40

45

50

55

EPO FORM P0459

For more details about this annex : see Official Journal of the European Patent Office, No. 12/82

REFERENCES CITED IN THE DESCRIPTION

This list of references cited by the applicant is for the reader's convenience only. It does not form part of the European patent document. Even though great care has been taken in compiling the references, errors or omissions cannot be excluded and the EPO disclaims all liability in this regard.

Patent documents cited in the description

- US 61433170 A [0001]
- US 4147107 A, Ringdal [0016]
- US 6845716 B, Hussein [0016]
- US 7213519 B, Wiley [0016]
- US 7610858 B, Chung [0016]