

(19) World Intellectual Property Organization
International Bureau



(43) International Publication Date
17 November 2005 (17.11.2005)

PCT

(10) International Publication Number
WO 2005/107536 A2

- (51) International Patent Classification⁷: A47F 5/08
 - (21) International Application Number: PCT/US2005/015955
 - (22) International Filing Date: 6 May 2005 (06.05.2005)
 - (25) Filing Language: English
 - (26) Publication Language: English
 - (30) Priority Data: 60/568,742 6 May 2004 (06.05.2004) US
 - (71) Applicant (for all designated States except US): DR. BROOKS INNOVATIONS, LLC [US/US]; c/o Dr. Brooks Innovations LLC, 680 Craig Road, Suite 304, St. Louis, MO 63141 (US).
 - (72) Inventors; and
 - (75) Inventors/Applicants (for US only): BROOKS, Jeffrey, S. [US/US]; 680 Craig Road, Suite 304, St. Louis, MO 63141 (US). DAMALAS, Konstantinos [US/US]; c/o Dr. Brooks Innovations LLC, 680 Craig Road, Suite 304, St. Louis, MO 63141 (US).
 - (74) Agents: TUEGEL, Donald, W. et al.; Senniger, Powers, Leavitt & Roedel, 1 Metropolitan Square, 16th Floor, St. Louis, MO 63102 (US).
 - (81) Designated States (unless otherwise indicated, for every kind of national protection available): AE, AG, AL, AM, AT, AU, AZ, BA, BB, BG, BR, BW, BY, BZ, CA, CH, CN, CO, CR, CU, CZ, DE, DK, DM, DZ, EC, EE, EG, ES, FI, GB, GD, GE, GH, GM, HR, HU, ID, IL, IN, IS, JP, KE, KG, KM, KP, KR, KZ, LC, LK, LR, LS, LT, LU, LV, MA, MD, MG, MK, MN, MW, MX, MZ, NA, NI, NO, NZ, OM, PG, PH, PL, PT, RO, RU, SC, SD, SE, SG, SK, SL, SM, SY, TJ, TM, TN, TR, TT, TZ, UA, UG, US, UZ, VC, VN, YU, ZA, ZM, ZW.
 - (84) Designated States (unless otherwise indicated, for every kind of regional protection available): ARIPO (BW, GH, GM, KE, LS, MW, MZ, NA, SD, SL, SZ, TZ, UG, ZM, ZW), Eurasian (AM, AZ, BY, KG, KZ, MD, RU, TJ, TM), European (AT, BE, BG, CH, CY, CZ, DE, DK, EE, ES, FI, FR, GB, GR, HU, IE, IS, IT, LT, LU, MC, NL, PL, PT, RO, SE, SI, SK, TR), OAPI (BF, BJ, CF, CG, CI, CM, GA, GN, GQ, GW, ML, MR, NE, SN, TD, TG).
- Published: — without international search report and to be republished upon receipt of that report

[Continued on next page]

(54) Title: A SYSTEM FOR HOLDING IMPLEMENTS

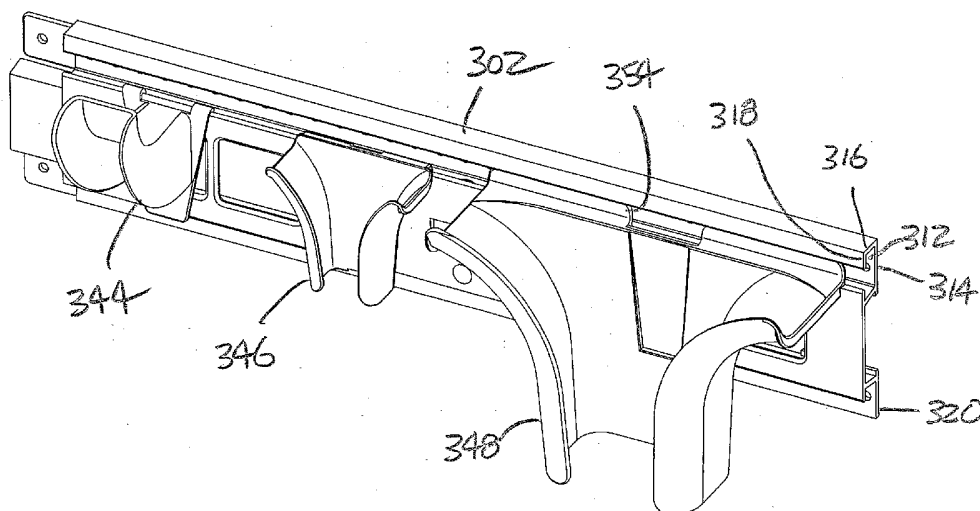

(57) Abstract: A system for holding one or more implements. The system includes a wall-mounted rail having a channel-track extending lengthwise of the rail, and an implement holder having a track-engaging element slidable in the channel-track to a selected position on the rail. Fastener holes are spaced at intervals along the bottom wall of the channel-track for receiving one or more rail fasteners to mount the rail. One implement holder comprises a jar assembly which includes a jar for storing items and a bracket mountable on the rail for holding the jar. Other implement holders may also be used, including an implement holder with a snap-lock fastener for releasable snap-fastening interconnection with the rail. A support places the holder at a different position relative to the rail. A wall mounted bracket may be used for supporting the holder.

WO 2005/107536 A2



For two-letter codes and other abbreviations, refer to the "Guidance Notes on Codes and Abbreviations" appearing at the beginning of each regular issue of the PCT Gazette.

A SYSTEM FOR HOLDING IMPLEMENTS

BACKGROUND OF THE INVENTION

This invention relates generally to devices for holding tools, utensils, household products and other consumer items, such items hereinafter being referred to generally as "implements". In particular, this invention is an improvement on the invention disclosed in my U.S. Patent No. 6,305,557 which is hereby incorporated by reference in its entirety.

SUMMARY OF THE INVENTION

10 Among the several objects of exemplary embodiments of this invention may be noted the provision of a unique system for holding and organizing various implements, including but not limited to those noted above; the provision of an exemplary system which is relatively
15 inexpensive and easy to assemble and use; and the provision of an exemplary system which can be expanded as needed to accommodate greater numbers and/or different types of implements.

In one aspect, a system of this invention for holding
20 one or more implements comprises a rail adapted to be mounted on a generally vertical mounting surface. An implement holder is configured to hold the one or more implements. The holder has at least one snap-lock fastener for snap-fastening engagement with the rail to releasably
25 fasten the holder at a fastened position on the rail.

In another aspect, a funnel-shaped holder of the invention is for holding an implement and which is configured for snap-fastening attachment to a wall mount having at least one edge for engagement by the holder. The
30 holder comprises a funnel structure having an upper end that flares open upwardly and is relatively wide for receiving the implement, a lower end that is relatively narrow, a rear wall with an inside surface and an outside surface, and opposite converging side walls which define,

in conjunction with the rear wall, a funnel-shaped recess for holding the implement in a stored position. A first fastening formation projects rearward of the rear wall for engagement with the wall mount. A second fastening formation projects rearward of the rear wall and is positioned in spaced relation from the first fastening formation for engagement with the wall mount. At least one of the first and second fastening formations comprises a snap-lock fastening formation configured for releasable snap-fastening interconnection with the wall mount.

Further, a support of the invention is for releasably supporting an implement holder on a rail mounted on a wall. The support comprises a rail fastening section having a snap-fastening formation configured for releasable snap-fastening engagement with the rail. A holder mounting section is for releasably mounting the holder on the support. The holder mounting section has a vertical platform connected adjacent its upper end to the rail fastening section.

In another aspect, a system of the invention is for holding one or more implements. The system comprises a wall mount adapted to be mounted on a generally vertical mounting surface. An implement holder is configured to hold the one or more implements. The holder has at least one snap-lock fastener for snap-fastening engagement with the wall mount to releasably fasten the holder at a fastened position on the wall mount.

In still a further aspect, a rail of the invention is adapted to be mounted in a generally horizontal position on a generally vertical mounting surface. The rail has a channel-track extending lengthwise of the rail. An implement holder having a track-engaging element is receivable in the channel-track and is slidable along the channel-track to a selected position on the rail. Each channel-track comprises a bottom wall adapted to be positioned generally adjacent the mounting surface, a pair of spaced-apart side walls extending forward from the bottom wall, and a slot at a front side of the

channel-track whereby when the track-engaging element of the implement holder is received in the channel-track between the side walls thereof, the track-engaging element is adapted to project forward through the slot and to be
5 slidably moved along the slot to move the implement holder to its desired position. Fastener holes are spaced at intervals along the bottom wall of the channel-track for receiving one or more rail fasteners to mount the rail on said mounting surface. The channel-track has a depth
10 sufficient to provide clearance between the track-engaging element and the one or more rail fasteners when the rail is mounted on said surface whereby the track-engaging element may be slidably moved along the channel-track without interference with the one or more rail fasteners.

15 In another aspect, the invention is directed to a jar assembly comprising a jar having a bottom, one or more sides, and a mouth. The assembly also includes a bracket comprising a back wall, a pair of generally opposing, spaced-apart sides extending forward from the back wall,
20 and opposing jar supports on the sides of the bracket for supporting the jar in an upright position for storage of items in the jar. Optionally, the bracket has a track-engaging element thereon for engaging a track on a rail to permit sliding movement of the bracket along the
25 rail.

Other objects and features will be in part apparent and in part pointed out hereinafter.

BRIEF DESCRIPTION OF THE DRAWINGS

Fig. 1 is a perspective of a system of the present
30 invention comprising a rail with a jar assembly and a funnel-shaped holder mounted on the rail;

Fig. 2 is a vertical section of the rail and jar assembly along line 2-2 of Fig. 1;

Fig. 2a is an enlarged view of a portion of Fig. 2
35 showing coupling of the jar assembly and the rail;

Fig. 3 is a perspective of a connection between two rails;

Fig. 3A is a perspective of the connected rails of Fig. 3;

Fig. 3B is a vertical section of the rail and associated connection along line 3B-3B of Fig. 3A;

5 Fig. 4 is a perspective of a bracket of the jar assembly of Fig. 1;

Fig. 5 is front elevation of the bracket of Fig. 4;

Fig. 6 is an exploded view various components of the system;

10 Fig. 7 is a top plan view of the jar assembly of Fig. 1;

Fig. 7A is an enlarged portion of Fig. 7;

Fig. 8 is a vertical section of the funnel-shaped holder and rail along line 8-8 of Fig. 1;

15 Fig. 9 is a vertical section of the larger funnel-shaped holder along line 9-9 of Fig. 6

Fig. 10 is an exploded front perspective of two rails of a second embodiment which are joined end-to-end;

20 Fig. 11 is a rear perspective of one of the rails of Fig. 10;

Fig. 12 is a front perspective of several implement holders fastened to one of the rails of Fig. 10;

Fig. 13 is a front perspective of an implement holder comprising a tool rack which is fastened to the rail;

25 Fig. 14 is a front perspective of an implement holder comprising a magnet fastened to the rail;

Fig. 15 is a front perspective of a funnel-shaped implement holder;

30 Fig. 16 is a rear perspective of the funnel-shaped implement holder of Fig. 15;

Fig. 17A is a side elevation of the funnel-shaped implement holder of Fig. 15;

Fig. 17B is a side elevation of the holder of Fig. 15 during installation onto the rail;

35 Fig. 17C is a view similar to Fig. 17B with the holder fully installed at a fastened position;

Fig. 18 is a front perspective of implement holders attached at several heights relative to the rail;

Fig. 19 is a front perspective of hanger supports fastened to the rail;

Fig. 20A is a side elevation of a single support fastened to the rail;

5 Fig. 20B is a side elevation of two supports mounted in series arrangement and fastened to the rail;

Fig. 21 is a side elevation of the funnel-shaped holder of Fig. 15 mounted on a hanger support;

Fig. 22A is a front perspective of a wall mount;

10 Fig. 22B is a rear perspective of the wall mount of Fig. 22A;

Fig. 22C is an exploded rear perspective of a holder and the wall mount;

15 Fig. 23A is a front perspective of a support of another embodiment fastened to the rail;

Fig. 23B is a side elevation of the support and rail; and

Fig. 23C is a rear perspective of the holder of Fig. 23A.

20 Corresponding parts are designated by corresponding numbers throughout the drawings.

DETAILED DESCRIPTION

Referring now to the drawings, Figs. 1 and 2 show one embodiment of a system of this invention, designated in its entirety by the reference numeral 1. As shown, the system comprises one or more rails, each generally designated 3, adapted to be mounted in a generally horizontal position on a generally vertical mounting surface 5 (Fig. 2). The mounting surface can be a pegboard, wall studs, a wall or any other type of surface suitable for mounting the one or more rails. In the illustrated embodiment, each rail (only one is shown in Fig. 1) comprises an elongate rail panel 9 and one or more channel-tracks on the rail panel, two such channel-tracks being shown in Fig. 1, the upper channel-track being designated 11 and the lower channel-track being designated 13. The system also includes one or more implement holders, two exemplary

holders being illustrated in Fig. 1. One of the implement holders, generally designated 17, is a jar assembly comprising a bracket, generally designated 19, and a jar, generally designated 21, removably mounted on the bracket 5 for holding items for storage. The bracket 19 has a track-engaging element 25 which may be slidably engaged with the upper channel-track 11 so that it can be moved to a selected position on the rail 3, as will be described in detail hereinafter. The second implement holder, generally designated 31, is funnel-shaped, as described in my U.S. Patent No. 6,305,557, and is attached to the rail 3 in a manner also to be described.

In the embodiment of Figs. 1 and 2, the elongate rail panel 9 of the rail 3 is relatively thin (e.g., 0.1 in. thick), flat and generally rectangular. The rail panel 9 has a front face facing away from the mounting surface and a back face facing toward the mounting surface. The rail panel 9 also has an upper edge margin terminating in an upper edge 37 extending lengthwise of the rail panel, a lower edge margin terminating in a lower edge 39 extending lengthwise of the rail panel, and opposite (left and right) end edges 41, 43. Other panel shapes are possible. The rail panel 9 has a plurality of fastener holes 45 in it for receiving fasteners 47 to fasten the holders 17, 31 in selected positions.

Referring to Figs. 2 and 2A, the upper channel-track 11 of the exemplary embodiment is disposed on the back face of the rail panel 9. The channel-track 11 comprises a bottom wall 51 adapted to be positioned generally adjacent the mounting surface 5, and a pair of spaced-apart side walls, one hereinafter being referred to as an upper side wall 53 and the other as a lower side wall 55. In the illustrated exemplary embodiment, the lower side wall 55 is connected to the upper edge margin of the rail panel 9 at a location below the upper edge 37 of the rail panel, and the upper side wall 53 is spaced above the upper edge 37 of the rail panel. The upper side wall 53 has an inturned lip 61 generally opposing the upper edge 37 of the rail panel to

define an upper slot 63 at the front side of the upper channel-track 11 extending the full length of the channel-track. The bottom wall 55 of the channel-track 11 has a plurality of fastener holes 67 (Fig. 2A) spaced at 5 intervals (preferably but not necessarily regular intervals such as every $\frac{1}{2}$ in.) along the channel-track for receiving one or more rail fasteners 71 to secure the rail to the mounting surface. These fasteners 71 may be common screws, for example, each having a head and a threaded shank 10 extending from the head. Advantageously, a depth D (Fig. 2A) of the channel from the plane of the slot 63 to the bottom wall 51 of the channel-track 11 is such that when the rail fasteners 71 are in place securing the rail to the mounting surface 5, there is sufficient clearance C (Fig. 15 2A) to permit implement holders (e.g., 17) having track-engaging elements (e.g., 25) to be slidably moved to their desired positions without interference with the heads of the fasteners. This clearance is preferably at least $\frac{1}{8}$ in., but this dimension may vary. The back surface of 20 the bottom wall 51 of the channel-track 11 has a pair of parallel ribs 77 thereon which contact the mounting surface 5 when the rail is secured thereto (see Fig. 2). The fastener holes 67 are located between these ribs 77 in the embodiment shown in the drawings.

25 The lower channel-track 13 is similar to the upper-channel track 11, also being disposed on the back face of the rail panel 9, as shown in Figs. 1 and 2. The lower channel-track 13 has a bottom wall 81 with parallel ribs 82 (Fig.2) which contact the mounting surface 5 and 30 parallel upper and lower side walls 83, 85. The lower side wall 85 has an inturned lip 89 which opposes the lower edge 39 of the rail panel to define a lower slot 91 which runs the length of the lower channel-track 13. Similar to the upper channel-track 11, the bottom wall 81 of the lower 35 channel-track has fastener openings 95 spaced at intervals along the wall, and sufficient clearance is provided to enable passage of a track-engaging element of a holder past

a fastener 71 in one of the openings 95 as the holder is moved along the lower channel-track 13.

As best illustrated in Figs. 1 and 3, the upper and lower slots 63, 91 in respective channel-tracks 9, 11 are enlarged to form one or more pairs of vertically aligned notches 101 at certain locations between the ends of the rail. (Only one such pair of notches 101 is shown in Fig. 3, but others may be provided.) Each notch 101 permits entry of a track-engaging element (e.g., 25) of an implement holder (e.g., 17) through a respective slot 63, 91 and into a respective channel-track 11, 13, thereby permitting the holder to be slidably moved to a selected position on the rail 3. Alternatively, the track-engaging element may be inserted into the channel-track from an end of the rail, assuming the end is accessible and not blocked by a connection to another rail or in some other way.

The rail panel 9 of the rail 3 and the upper and lower channel-tracks 11, 13 may be integrally formed (e.g., molded) as a single piece or formed as separate pieces and then connected in suitable fashion. The various components may be of plastic or other suitable material.

As illustrated in Figs. 3-3B, multiple rails 3 may be connected together end to end to increase the capacity of the system (e.g., the number of holders used). To facilitate such connection, each rail 3 includes a connection section 113 at one end (the left end as viewed in Fig. 3) configured for an overlapping fit with the opposite (right) end of an adjacent rail. In the illustrated embodiment, the connection section 113 of the rail comprises a connection panel 115 offset in a rearward direction relative to the rail panel 9, and upper and lower connection channel-tracks 117, 119 which are enlarged in transverse cross section relative to the rail channel-tracks 11, 13. The arrangement is such that the right end of each rail 3 is configured for an overlapping (e.g., telescoping) fit with the connection section 113 at the left end of an adjacent rail. When the rails of this embodiment are thus connected, the rail panels 9 of the two

rails 3 are generally co-planar and closely adjacent or butted up against one another, and the upper and lower rail channel-tracks 9, 13 of the two rails are closed adjacent or butted up against one another to provide a substantially 5 uninterrupted or seamless continuation of the rail panels, rail channel-tracks and slots from one rail to the next (see Fig. 3). The rails are held in fixed position relative to one another after they are connected by fastening each rail to the mounting surface 5 using the 10 aforementioned rail fasteners 71. The overlapping telescoping connection between the rails 3 may also be accompanied by a friction-fit between the parts. The connection panel 115 of the connection section 113 has fastener holes 131 in it for securing an implement holder 15 at this location, if desired. The bottom walls of the connection channel-tracks 117, 119 also have fastener holes 121 for receiving fasteners (e.g., 71) to secure the rail 3 to the mounting surface 5.

As shown in Figs. 2 and 6, the jar 21 of the jar 20 assembly 17 has a bottom 151, a cylindric side wall 153 defining an open mouth 155 at the upper end of the jar, and a circular peripheral flange structure 161 projecting out from the side wall of the jar at its mouth. The jar may have other shapes (e.g., rectangular) without departing 25 from the scope of this invention. Further, the flange structure 161 may be formed as one continuous flange or one or more flange segments. In one embodiment, the jar 21 is made of a resilient material (e.g., resilient molded plastic), but it may also be rigid. The jar may have any 30 suitable capacity.

The bracket 19 of the jar assembly 17 shown in Figs. 2 and 4-6 includes a pair of spaced-apart, generally parallel side walls 171, a top wall 173 spanning the side walls, and a back wall 175. The track-engaging element 25 comprises a 35 J-shaped member or hook extending up from the top wall 173 adjacent its back edge. In other embodiments, the track-engaging element 25 may have other shapes and may be at other locations on the bracket 19. The entire bracket

19, including the track-engaging element 25, may be a one-piece molded unit of a suitable plastic material, for example. To mount the bracket 19 on the rail, the track-engaging element 25 may be inserted into and through 5 the enlarged notch 101 in the upper slot 63 and then slidably moved along the channel-track 11 to a selected position. The bracket 19 may be secured in that position by one or more fasteners (e.g., screws 181 in Fig. 6) extending through selected one or more mounting openings 10 183 in the back wall 175 of the bracket into the rail panel. The screws 181 preferably have a length such that they do not screw into the mounting surface 5. In the embodiment shown in Fig. 5, the mounting openings 183 in the back wall 175 of the bracket 19 are in the form of 15 slots extending up from the lower edge of the back wall. This configuration allows for some range of adjustment of the elevation of the bracket relative to the rail 3, as needed or desired.

As shown best in Figs. 4 and 5, the side walls 171 of 20 the bracket 19 are formed with opposing jar supports 191, and the back wall 175 of the bracket is formed with a jar support 193. All of these supports 191, 193 are spaced below the top wall 173 of the bracket and define a slideway 195 for slidably receiving the jar 21. In the illustrated 25 embodiment (Figs. 4 and 5), the jar supports 191 comprise ledges projecting from respective back and side walls 171, 175 for supporting portions of the flange structure 161 on the jar. The flange structure 161 is adapted to rest on the jar supports when the jar is slidably moved into the 30 slideway 195 to a storage position below the top wall of the bracket, which serves as a cover for the jar (Figs. 1 and 2). The front portion of each side wall support 191 is sloped to provide a lead-in ramp 199 to facilitate movement of the jar into the slideway 195.

35 The bracket 19 also includes a detent mechanism for releasably holding the jar 21 in its storage position below the top wall 173 of the bracket. In the embodiment shown in Figs. 4-7A, this detent mechanism comprises a pair of

detents 201 in the form of opposing bosses or projections on the side walls 171 of the bracket 19 above the jar supports 191. These detents define a distance D2 (Fig. 7A) across the slideway 195 less than an outside diameter of 5 the jar 21 (e.g., less than the diameter of the peripheral flange structure 161). The jar 21 and/or the detents 201 are resiliently deformable to permit the jar to be slidably pushed (preferably but not necessarily with a twist) into the slideway 195 past the detent mechanism (i.e., in a 10 direction toward the back wall 175 of the bracket 19) to an over-center position (Fig. 7) in which the maximum diameter of the jar, in this case the flange structure 161 of the jar, is located to the rear of the detents 201, thereby allowing the detents to snap back toward their original 15 position for releasably holding the jar against withdrawal from the slideway. To remove the jar, it is simply pulled in a forward direction (preferably but not necessarily with a twist) with sufficient force to resiliently deform the detents 201 and/or the jar 21 to allow the jar to move 20 forward past the detents and out of the slideway 195, either partially or entirely.

In other embodiments (not shown), multiple jars of different capacities may be used in conjunction with the same bracket 19, or multiple brackets 19 may be provided 25 each having its own dedicated jar of appropriate size. Any number of jar assemblies (from one to two or more) can be mounted on the rail(s) 3.

In still other embodiments, the bracket 19 may be made without a track-engaging element 25. In this case, the 30 bracket is simply secured to the rail 3 by one or more fasteners 181 extending through suitable openings (e.g., 183) in the back wall of the bracket into selected holes 45 in the rail panel 9.

Referring to Figs. 1 and 8, the funnel-shaped holder 35 31 is of relatively small size but otherwise has the shape and functional characteristics described in my aforementioned patent. The holder is formed with a standoff 213 on the back wall 215 of the holder which is

adapted to lie flat against the rail panel 9 for stability. One or more fasteners (e.g., screws 47) may be used to secure the holder 31 to the rail panel 9 in any desired position along the rail, with each fastener extending 5 through holes 217 in the back wall 215 and standoff 213 of the holder into a selected fastener hole 45 in the rail panel 9. The holder fasteners 47 are preferably dimensioned such that when threaded in place, they do not extend rearward beyond the bottom wall 51 of the upper 10 channel-track 11 or the bottom wall 81 of the lower channel-track 13, so that they do not penetrate the rail mounting surface 5. The holder 31 may be a one-piece molded part.

The rail 3 is also suited for mounting a larger 15 funnel-shaped holder, generally designated 225 in Figs. 6 and 9. This holder 225 has a pair of upper track-engaging elements 227 slidable in the upper channel-track 11 and a lower track-engaging element 231 (Fig. 9) slidable in the lower channel-track 13. In one embodiment, the 20 track-engaging elements 227, 231 are J-shaped members or hooks integrally formed with the back wall 235 of the holder, but the track-engaging elements may have other shapes and locations. Reference may be made to my aforementioned U.S. Patent No. 6,305,557 for further 25 details regarding the design and operation of this type of holder. When the holder 225 is mounted on the rail 3, the track-engaging elements 227, 231 extend forward through respective slots 63, 91. The holder 225 may be slidably moved into a desired position along the rail 3, there being 30 sufficient clearance in the channel-tracks 11, 13 between the rail fasteners 71 and the track-engaging elements 227, 231 as discussed above. Once in place, the holder 225 may be secured to the rail panel 3 by inserting fasteners (not shown) through one or more fastener holes 241 in the back 35 wall 235 of the holder and then threading them into one or more selected aligned fastener holes 45 in the rail panel 9. The holder fasteners are preferably dimensioned such that when threaded in place, they do not extend rearward

beyond the bottom wall 51 of the upper channel-track 11 or the bottom wall 81 of the lower channel-track 13, so that they do not penetrate the rail mounting surface 5.

A second embodiment 300 of a system of the present invention for holding one or more implements is shown in Figs. 10-21. This system is similar in many respects to the system described above but with the additional advantage of being more compact, requiring less material, and providing greater flexibility of use. The system includes a rail 302 adapted to be mounted on a generally vertical mounting surface 304, and an implement holder 306 having a snap-lock fastener 308 for snap-fastening engagement with the rail to releasably fasten the holder at a fastened position on the rail. This snap-fastening feature provides an advantage in that the holder may be readily mounted at any desired position along the rail. Further, the inter-connection provides a generally tight, friction fit so that the holder will not inadvertently slide along the rail. When the holder is at its fastened position, the holder 306 and rail 302 exert relative frictional forces sufficient to prevent unintentional relative movement of the holder along the rail.

Referring to Figs. 10 and 11, the rail 302 of this embodiment comprises a front panel 310, an upper channel-track 312 which includes a back wall 314, an upper side wall 316, an inturned lip 318, and a lower mounting structure having a back wall 320 with no side wall or lip. One or more window openings 322 may be placed in the front panel 310, as shown in the illustrated embodiment, to reduce the mass of the rail. Preferably, the aggregate window openings represent a reduction of at least 20% of the rail mass.

The rail 302 is configured to have a telescoping end-to-end fit with a second rail. In one embodiment (Figs. 10 and 11), each rail 302 has a connecting region 324 at one end with surfaces which are recessed relative to the other portions of the rail, such that the connecting region telescopes into the opposite end of an adjacent rail.

Upper and lower tabs 326 comprise extensions of the back walls 314, 320 of the upper channel-track and lower mounting structure, respectively. The resulting joint is stable, with smoothly adjacent (i.e., flush) surfaces on 5 front and back sides of the rail.

The front panel 310 of each rail comprises a mount for mounting implement holders on the rail. A front face 330 of the panel faces away from the vertical mounting surface 304, and a back face 332 of the panel faces toward the 10 mounting surface. When two rails 302 are interconnected, the front faces 330 of the front panels of adjacent rails are substantially coplanar. The mount (e.g., panel 310) has first and second vertically spaced edges 334, 336. In the embodiment shown in the drawings, the edges are 15 generally parallel upper and lower edges spaced apart to define a height of the front face of the mount.

In one embodiment, a level 340 is mounted on the rail 302 for accurately positioning the rail at a level orientation on the mounting surface. The level 340 is 20 mounted on the back face 332 of the mount by suitable means (e.g., a clip), and it is visible from the front of the rail through a viewing window 342 in the front panel 310.

The system is versatile and can mount a variety of types of holders for supporting objects of various 25 configurations. In addition to a jar, the implement holder may comprise an upturned hook 344 (Fig. 12), a smaller funnel 346, a larger funnel 348 (Fig. 12), a tool rack 350 (Fig. 13), or a magnet 352 (Fig. 14). Other types, shapes, and sizes of accessories do not depart from the scope of 30 this invention. Each of the holders may be configured for snap-fastening attachment to the rail 302 at any desired lateral location, or could be slid onto the rail from an end of the rail to the desired location. In the illustrated embodiment, the larger funnel 348 (Fig. 12) has 35 upper tab extensions 354 which extend into the generally enclosed region of the upper channel-track 312 adjacent the inturned lip 318. That can improve the stability and strength, especially when supporting heavier implements.

Referring to Figs. 15-17, an embodiment of the smaller funnel-shaped holder 346 is shown. The holder is configured for snap-fastening attachment to a wall mount (e.g., the rail 302). The holder 346 has a funnel structure with an upper end that flares open upwardly and is relatively wide for receiving an implement, a lower end that is relatively narrow, a rear wall 360 with an inside surface and an outside surface, and opposite converging side walls 362 which define, in conjunction with said rear wall, a funnel-shaped recess for holding the implement in a stored position.

In the embodiment shown in the drawings, the funnel 346 has first and second fastening formations 364, 366 which each project rearward of the rear wall 360, as shown in Fig. 17A, for engagement with the mount. The second fastening formation 366 is positioned in spaced relation from the first fastening formation 364. The second fastening formation comprises a snap-lock fastening formation configured for releasable snap-fastening interconnection with the mount 310. It is understood that there may be a different number, shape, or arrangement of fastener means, in particular a different number or configuration of snap-lock fastening formation(s), without departing from the scope of this invention. In one embodiment, the funnel and fastening formations have a one-piece, molded body.

Further, although the formations herein are discussed with respect to the funnel 346, they may be similarly configured for other types of holders.

The first fastening formation 364 comprises a hook-shaped fastening formation positioned near the upper end of the funnel. It extends horizontally along at least a portion of the holder. In the embodiment shown in Fig. 16, there are two spaced segments of the formation 364. The hook-shaped formation has a first portion (Fig. 17A) projecting rearward from the holder and a second portion projecting generally vertically down from the first

portion, and is sized for engaging the upper edge 334 of the front panel 310.

The second fastening formation 366 (i.e., the snap-lock fastening formation) comprises a tab projecting from the holder near the lower end of the funnel for resilient snap-fastening engagement with the mount 310. In the illustrated embodiment, the tab 366 is positioned for engaging the lower edge 336 of the front panel 310. It is understood that it could engage another portion of the rail without departing from the scope of this invention. The tab is configured to be resiliently deflectable. A locking member 370 is positioned on the tab. In the illustrated embodiment, the locking member 370 comprises a protuberance.

To fasten the holder 346 to the mount, a person first places the hook-shaped fastening formation 364 in engagement with the upper edge 334. Next, the lower portion of the holder is moved toward the fastened position (as shown in Fig. 17B). As it moves, the tab 366 deflects such that the locking member 370 is free to move from an initial position engaging the front face 330 of the mount, past the lower edge 336, and to a position engaging the back face 332 of the mount whereupon the tab snaps back toward an undeflected position, thereby releasably fastening the holder at the fastened position. A spacing between the hook-shaped fastening formation 364 and the tab 366 is such that when the holder is placed at the fastened position, the fastening formation 364 and tab 366 exert a clamping force against the upper and lower edges 334, 336 to hold the holder in the fastened position.

The tab 366 also functions as a release for unfastening the holder from the mount. A person pulls on the end of the tab to release the locking member from its position and remove the holder.

A support 380 of the invention may be used to place a holder at a different position relative to the rail 302 (e.g., at a different vertical position). The support 380 is mountable on the rail and adapted for releasably

supporting an implement holder thereon. The support 380 has a snap-fastening formation adapted to engage the rail at a fastening location. The support extends downward from its fastening location and is adapted for releasably supporting the holder at an elevation wherein at least a portion of the holder is mounted below the fastening location. Alternatively, the support can extend upward (not shown) from its fastening location and is adapted for releasably supporting the holder at an elevation wherein at least a portion of the holder is mounted above the fastening location.

In one embodiment, the support 380 includes a rail fastening section 382 having a snap-fastening formation 383 (Fig. 21) configured for releasable mounting on the rail, and a holder mounting section 384 for releasably mounting a holder. The formation 383 comprises a protuberance. The holder mounting section has a vertical platform 388 connected at its upper end to the rail fastening section by a C-shaped connecting strip 390. Significantly, the holder mounting section is configured to have the same height as the front panel 310 such that a holder can be mounted to either the front panel or the support. The rail fastening section has a front surface generally coplanar with the platform 388 of the holder mounting section. An upper tab extension 394 reaches into the enclosed portion of the channel-track 312, for greater stability. A stabilizer leg 396 is for engagement with a vertical wall 304. Alternatively, the support can be suspended from the rail, without engaging a wall. In one embodiment, the support comprises a one-piece molded body.

Multiple supports 380 may be cascaded in a series arrangement, as shown in Figs. 18 and 19, to increase the spacing from the rail. A second support is mounted on the first support for supporting the holder by both first and second supports.

An alternate embodiment 400 of the support is shown in Figs. 23A-23C. Vertical ribs 402 are positioned on front and back sides. A positioning system is on the support and

holder for preventing lateral shifting of the holder relative to the support. The spacing between the two segments of the hook-shaped fastening formation are spaced to match the spacing around the ribs 402. Other types of
5 positioning systems do not depart from the scope of this invention (e.g., detents).

Referring to Fig. 22A-22C, a wall mount 410 of the invention is adapted to be mounted on a generally vertical mounting surface. In the embodiment shown in the drawings,
10 the wall mount 410 comprises a generally flat bracket, although other configurations are possible. The wall mount bracket includes one or more bosses 412 on its back side with an opening for receiving a fastener to fasten the wall
15 the rail, and it has the same height dimension as the front panel 310.

Implement holders with a snap-lock formation may be releasably snap-fastened to the wall mount. The wall mount and holder also have the positioning system, as shown in
20 Fig. 22C, for preventing lateral shifting of the holder relative to the wall mount bracket. The wall mount may include a level at its center window 414.

When introducing elements of the present invention or the preferred embodiments(s) thereof, the articles "a",
25 "an", "the" and "said" are intended to mean that there are one or more of the elements. The terms "comprising", "including" and "having" are intended to be inclusive and mean that there may be additional elements other than the listed elements.

30 In view of the above, it will be seen that the several objects of the invention are achieved and other advantageous results attained.

As various changes could be made in the above constructions without departing from the scope of the
35 invention, it is intended that all matter contained in the above description and shown in the accompanying drawing[s] shall be interpreted as illustrative and not in a limiting sense.

WHAT IS CLAIMED IS:

1. A system for holding one or more implements, said system comprising:
 - a rail adapted to be mounted on a generally vertical mounting surface; and
 - 5 an implement holder configured to hold said one or more implements, the holder having at least one snap-lock fastener for snap-fastening engagement with the rail to releasably fasten the holder at a fastened position on the rail.
2. A system as set forth in claim 1 wherein when the holder is at its fastened position, the holder and rail exert relative frictional forces sufficient to prevent unintentional relative movement of the holder along the
5 rail.
3. A system as set forth in claim 1 wherein the rail has a mount with a front face adapted to face away from said mounting surface, a back face adapted to face toward said mounting surface, and first and second vertically
5 spaced edges extending generally parallel to one another along the rail, said holder being slidable along the edges to a selected position on the rail.
4. A system as set forth in claim 3 wherein said snap-lock fastener comprises a tab projecting from the holder for resilient snap-fastening engagement with one of said edges.
5. A system as set forth in claim 4 further comprising a locking member on the tab.
6. A system as set forth in claim 5 wherein the locking member comprises a protuberance on the tab.

7. A system as set forth in claim 5 wherein the tab of said snap-lock fastener is resiliently deflectable as the holder is moved to said fastened position such that said locking member is free to move from a position
5 engaging the front face of the rail, past said one edge, and to a position engaging the back face whereupon the tab snaps back toward an undeflected position thereby to releasably fasten the holder at the fastened position.

8. A system as set forth in claim 7 wherein the holder further comprises a hook-shaped fastening formation positioned in spaced relation from the snap-lock fastener.

9. A system as set forth in claim 8 wherein the hook-shaped fastening formation extends horizontally along at least a portion of said holder.

10. A system as set forth in claim 9 wherein said hook-shaped formation has a first portion projecting rearward from the holder and a second portion projecting generally vertically from the first portion.

11. A system as set forth in claim 10 wherein the first and second edges of the rail mount are generally parallel upper and lower edges vertically spaced from one another.

12. A system as set forth in claim 11 wherein a spacing between the hook-shaped fastening formation and the snap-lock fastener is such that when the holder is placed at the fastened position, the fastening formation and the
5 snap-lock fastener exert a clamping force against said upper and lower edges to hold the holder in said fastened position.

13. A system as set forth in claim 1 wherein said rail comprises a first rail, and wherein said system further comprises a second rail having a telescoping fit with the first rail.

14. A system as set forth in claim 1 wherein the rail comprises an elongate rail adapted for mounting in a generally horizontal orientation, and wherein said system further comprises a level on the rail.

15. A system as set forth in claim 14 further comprising a viewing window in the rail, and wherein the rail has a holder mount with a front face adapted to face away from said mounting surface and a back face adapted to face toward said mounting surface, and wherein the level is mounted on said back face of the holder mount and visible from the front face through the viewing window.

16. A system as set forth in claim 1 further comprising one or more window openings in the rail resulting in a reduction in rail mass, said one or more window openings representing at least 20% of the rail mass.

17. A system as set forth in claim 1 wherein said implement holder comprises a funnel.

18. A system as set forth in claim 1 wherein said implement holder comprises a hook.

19. A system as set forth in claim 1 wherein said implement holder comprises a tool rack.

20. A system as set forth in claim 1 wherein said implement holder comprises a magnet.

21. A system as set forth in claim 1 further comprising a support mountable on the rail and adapted for releasably supporting an implement holder thereon.

22. A system as set forth in claim 21 wherein the support has a snap-fastening formation adapted for snap-fastening engagement with the rail.

23. A system as set forth in claim 22 wherein the support snap-fastens to the rail at a fastening location, and wherein the support extends downward from its fastening location and is adapted for releasably supporting snap
5 implement holder at an elevation wherein at least a portion of the holder is mounted below the fastening location.

24. A system as set forth in claim 22 wherein the support snap-fastens to the rail at a fastening location, and wherein the support extends upward from its fastening location and is adapted for releasably supporting the
5 holder at an elevation wherein at least a portion of the holder is mounted above the fastening location.

25. A system as set forth in claim 22 wherein said support is a first support, said system further comprising a second support mountable on the first support with one support above the other support, and wherein said implement
5 holder is adapted to be mounted on said second support.

26. A system as set forth in claim 21 further comprising a positioning system on the support and holder for preventing lateral shifting of the holder relative to the support.

27. A funnel-shaped holder for holding an implement and which is configured for snap-fastening attachment to a wall mount having at least one edge for engagement by said holder, the holder comprising:
5 a funnel structure having an upper end that flares open upwardly and is relatively wide for receiving said implement, a lower end that is relatively narrow, a rear wall with an inside surface and an outside surface, and opposite converging side walls which define, in conjunction

with said rear wall, a funnel-shaped recess for holding said implement in a stored position;

a first fastening formation projecting rearward of the rear wall for engagement with said wall mount; and

5 a second fastening formation projecting rearward of the rear wall and positioned in spaced relation from the first fastening formation for engagement with said wall mount; and

10 wherein at least one of said first and second fastening formations comprises a snap-lock fastening formation configured for releasable snap-fastening engagement with said wall mount.

28. A funnel-shaped holder as set forth in claim 27 wherein said snap-lock fastening formation comprises a tab having a locking member thereon for engagement with said edge of the wall mount, the tab being resiliently
5 deflectable for deflection as the holder is moved past said edge of the wall mount and thereafter snaps back toward an undeflected position wherein the locking member cannot move past said edge.

29. A funnel-shaped holder as set forth in claim 28 wherein said locking member comprises a protuberance on the tab.

30. A funnel-shaped holder as set forth in claim 29 wherein the first fastening formation has a hook-shape and extends horizontally along a portion of said rear wall, and the second fastening formation comprises said snap-lock
5 formation.

31. A funnel-shaped holder as set forth in claim 30 wherein said wall mount is a rail.

32. A funnel-shaped holder as set forth in claim 30 wherein said wall mount is a bracket.

33. A support for releasably supporting an implement holder on a rail mounted on a wall, said support comprising:

a rail fastening section having a snap-fastening formation configured for releasable snap-fastening engagement with said rail; and

a holder mounting section for releasably mounting said holder on the support; and

wherein the holder mounting section has a vertical platform connected adjacent its upper end to the rail fastening section.

34. A support as set forth in claim 33 wherein the rail fastening section has a front surface generally coplanar with a front surface of said platform of the holder mounting section.

35. A support as set forth in claim 33 wherein the holder mounting section further comprises a stabilizer leg for engagement with said wall.

36. A support as set forth in claim 33 wherein the support comprises a one-piece body.

37. A system for holding one or more implements, said system comprising:

a wall mount adapted to be mounted on a generally vertical mounting surface; and

an implement holder configured to hold said one or more implements, the holder having at least one snap-lock fastener for snap-fastening engagement with the wall mount to releasably fasten the holder at a fastened position on the wall mount.

38. A system as set forth in claim 37 wherein said wall mount comprises a bracket having at least one opening for receiving a fastener to fasten the bracket to said generally vertical mounting surface.

39. A system as set forth in claim 37 further comprising a positioning system on the wall mount and holder for preventing lateral shifting of the holder relative to the wall mount.

40. A system for holding one or more implements, said system comprising

a rail adapted to be mounted in a generally horizontal position on a generally vertical mounting surface, said rail 5 having a channel-track extending lengthwise of the rail,

an implement holder having a track-engaging element receivable in said channel-track and slidable along the channel-track to a selected position on the rail,

said channel-track comprising a bottom wall adapted to 10 be positioned generally adjacent said mounting surface, a pair of spaced-apart side walls extending forward from said bottom wall, and a slot at a front side of the channel-track whereby when said track-engaging element of the implement holder is received in the channel-track between the side 15 walls thereof, said element is adapted to project forward through the slot and to be slidably moved along the slot to move said implement holder to said desired position,

a plurality of fastener holes spaced at intervals along the bottom wall of the channel-track for receiving one or 20 more rail fasteners to mount the rail on said mounting surface,

said channel-track having a depth sufficient to provide clearance between the track-engaging element and said one or more rail fasteners when the rail is mounted on said surface 25 whereby the track-engaging element may be slidably moved along the channel-track without interference with said one or more rail fasteners.

41. A system as set forth in claim 40 wherein said rail comprises an elongate rail panel having a front face adapted to face away from said mounting surface and a back face adapted to face said mounting surface, and wherein said

5 channel-track is disposed on the back face of the rail panel.

42. A system as set forth in claim 41 wherein said elongate rail panel has an upper edge margin terminating in an upper edge extending lengthwise of the rail panel, a lower edge margin terminating in a lower edge extending
5 lengthwise of the rail panel, and opposite end edges, one side wall of said pair of side walls of said channel-track, constituting a lower side wall, extending along said upper edge margin of the rail panel at a location spaced below
10 of said pair of said walls, constituting an upper side wall, being located above said upper edge of the rail panel and having an inturned lip generally opposing said upper edge of the rail panel, said lip and upper edge of the rail panel defining said slot.

43. A system as set forth in claim 42 wherein said channel-track comprises an upper channel-track disposed generally adjacent said upper edge of said rail panel, and wherein said system further comprises a lower channel-track
5 disposed generally adjacent said lower edge of said rail panel and running generally parallel to said upper channel track.

44. A system as set forth in claim 41 wherein said channel-track comprises an upper channel-track disposed generally adjacent an upper edge of said rail panel, and wherein said system further comprises a lower channel-track
5 disposed generally adjacent a lower edge of said rail panel and running generally parallel to said upper channel track.

45. A system as set forth in claim 44 wherein each rail has a connection section at one configured for an overlapping fit with an end of an adjacent rail thereby to join the rails end-to-end.

46. A system as set forth in claim 45 wherein said connection section of each rail is configured for a telescoping fit with said end of said adjacent rail.

47. A system as set forth in claim 41 further comprising one or more holder fasteners for mounting said implement holder on said rail panel, said rail panel having a plurality of fastener holes therein for receiving said one or more holder fasteners, said one or more holder fasteners having a length such that when the one or more holder fasteners are in place fastening said implement holder to the rail panel, the one or more holder fasteners do not extend rearward beyond said channel-track into said mounting surface.

48. A system as set forth in claim 40 wherein each of said one or more rail fasteners is a screw having a head disposed inside said channel-track and a threaded shank threadable into said mounting surface.

49. A system as set forth in claim 40 wherein said implement holder comprises a jar assembly comprising a jar having a bottom, one or more sides, and a mouth, and a bracket having said track-engaging element thereon, said bracket comprising a pair of generally opposing, spaced-apart sides, and opposing jar supports on the sides of the bracket for supporting said jar in an upright position for storage of items in the jar.

50. A system as set forth in claim 49 wherein said jar has a flange structure projecting out from said one or more sides of the jar adapted to rest on said jar supports.

51. A system as set forth in claim 50 wherein said bracket further comprises a top wall spanning said sides, said jar supports on the sides of the bracket being spaced below said top wall and defining a slideway for slidably receiving the flange structure of the jar whereby the jar

may be slidably moved in said slideway to a storage position in which the mouth of the jar is disposed below the top wall of the bracket.

52. A system as set forth in claim 51 wherein top wall is sized to cover the mouth of the jar when the jar is in said storage position.

53. A system as set forth in claim 51 further comprising a detent mechanism for releasably holding said jar in said storage position.

54. A system as set forth in claim 53 wherein said detent mechanism defines a distance across the slideway less than an outside diameter of the jar, one or both of said jar and detent mechanism being resilient deformable to permit
5 the jar to be slidably moved into the slideway past the detent mechanism to an over-center position in which the jar is releasably held against withdrawal from the slideway.

55. A system as set forth in claim 54 wherein said detent mechanism comprises a pair of detents protruding inwardly from opposite sides of the bracket into said slideway above said jar supports.

56. A jar assembly comprising
a jar having a bottom, one or more sides, and a mouth,
and
a bracket having a track-engaging element thereon for
5 engaging a track on a rail to permit sliding movement of the bracket along the rail,
said bracket comprising a pair of generally opposing, spaced-apart sides, and opposing jar supports on the sides of the bracket for supporting said jar in an upright
10 position for storage of items in the jar.

57. A jar assembly as set forth in claim 56 wherein said jar has a flange structure projecting out from said one or more sides of the jar adapted to rest on said jar supports.

58. A jar assembly as set forth in claim 57 wherein said bracket further comprises a top wall spanning said sides, said jar supports on the sides of the bracket being spaced below said top wall and defining a slideway for
5 slidably receiving the flange structure of the jar whereby the jar may be slidably moved in said slideway to a storage position in which the mouth of the jar is disposed below the top wall of the bracket.

59. A jar assembly as set forth in claim 58 wherein top wall is sized to cover the mouth of the jar when the jar is in said storage position.

60. A jar assembly as set forth in claim 58 further comprising a detent mechanism for releasably holding said jar in said storage position.

61. A jar assembly as set forth in claim 60 wherein said detent mechanism defines a distance across the slideway less than an outside diameter of the jar, one or both of said jar and detent mechanism being resilient deformable to
5 permit the jar to be slidably moved into the slideway past the detent mechanism to an over-center position in which the jar is releasably held against withdrawal from the slideway.

62. A jar assembly as set forth in claim 61 wherein said detent mechanism comprises a pair of detents protruding inwardly from opposite sides of the bracket into said slideway above said jar supports.

63. A jar assembly comprising
a jar having a bottom, one or more sides, and a mouth,
and

a bracket comprising a back wall, a pair of generally
5 opposing, spaced-apart sides extending forward from the back
wall, and opposing jar supports on the sides of the bracket
for supporting said jar in an upright position for storage
of items in the jar.

64. A jar assembly as set forth in claim 63 wherein
said back wall has fastener openings therein for receiving
fasteners to fasten the bracket to a surface.

2/23

FIG. 2

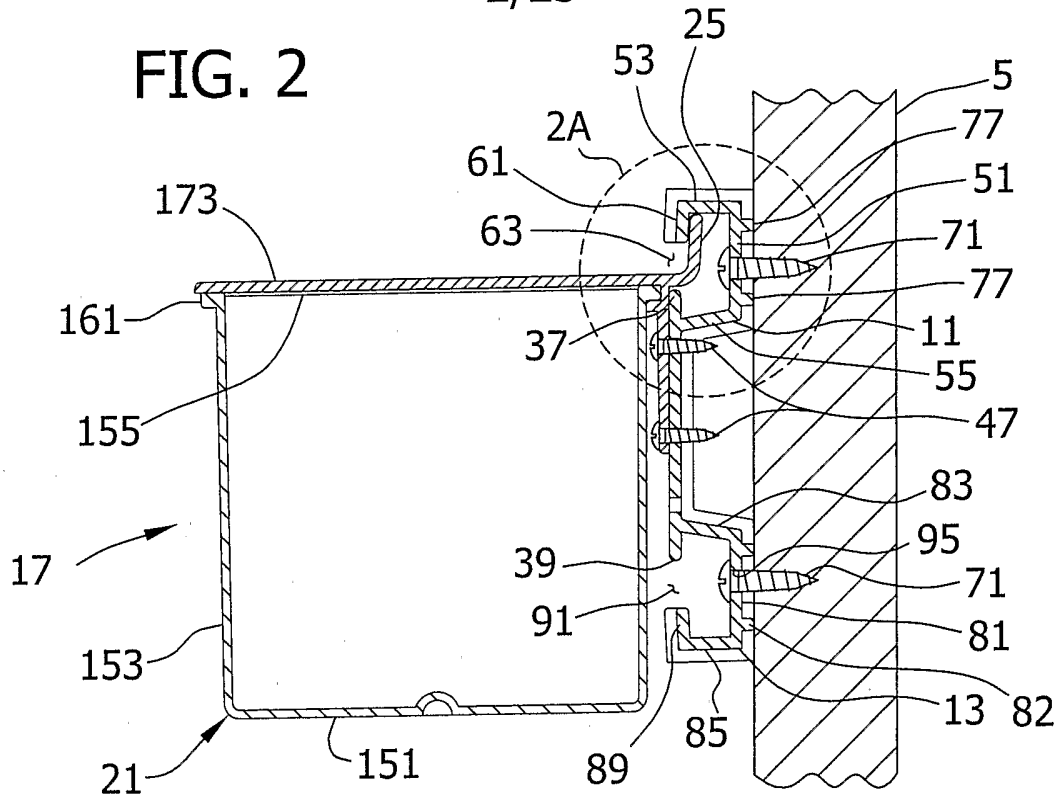
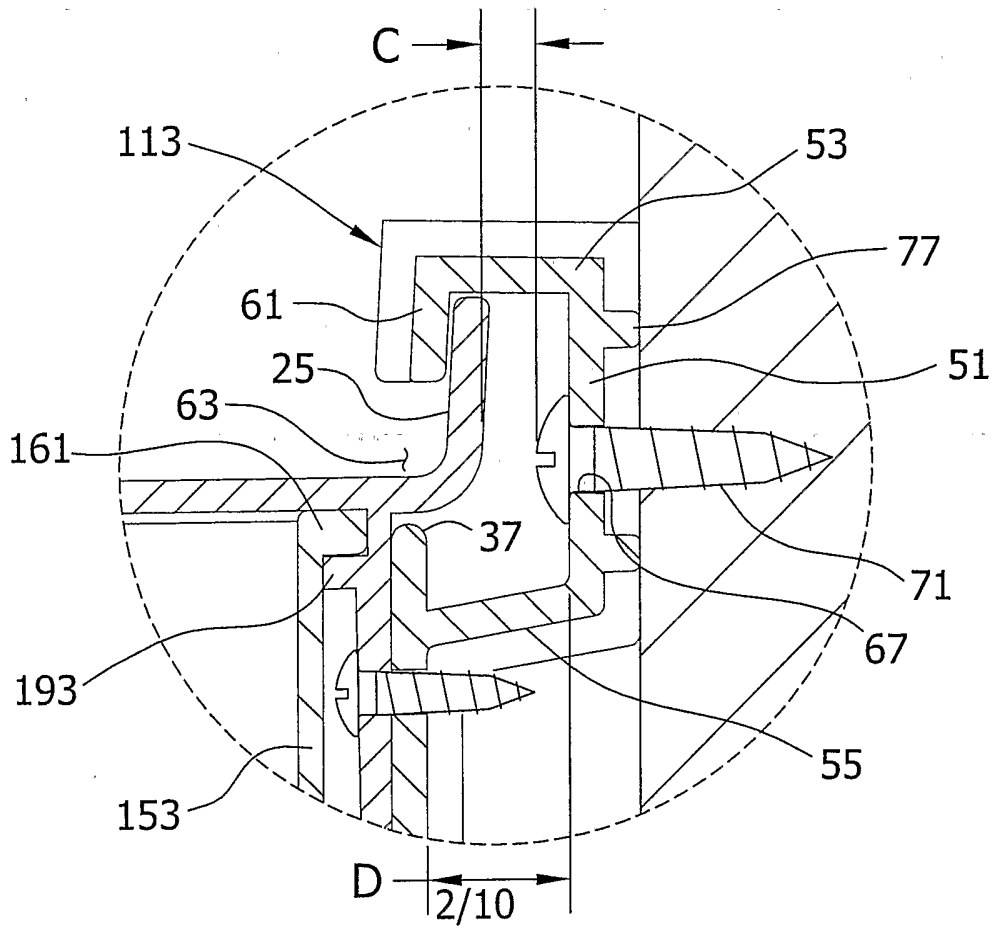

FIG. 2A



3/23

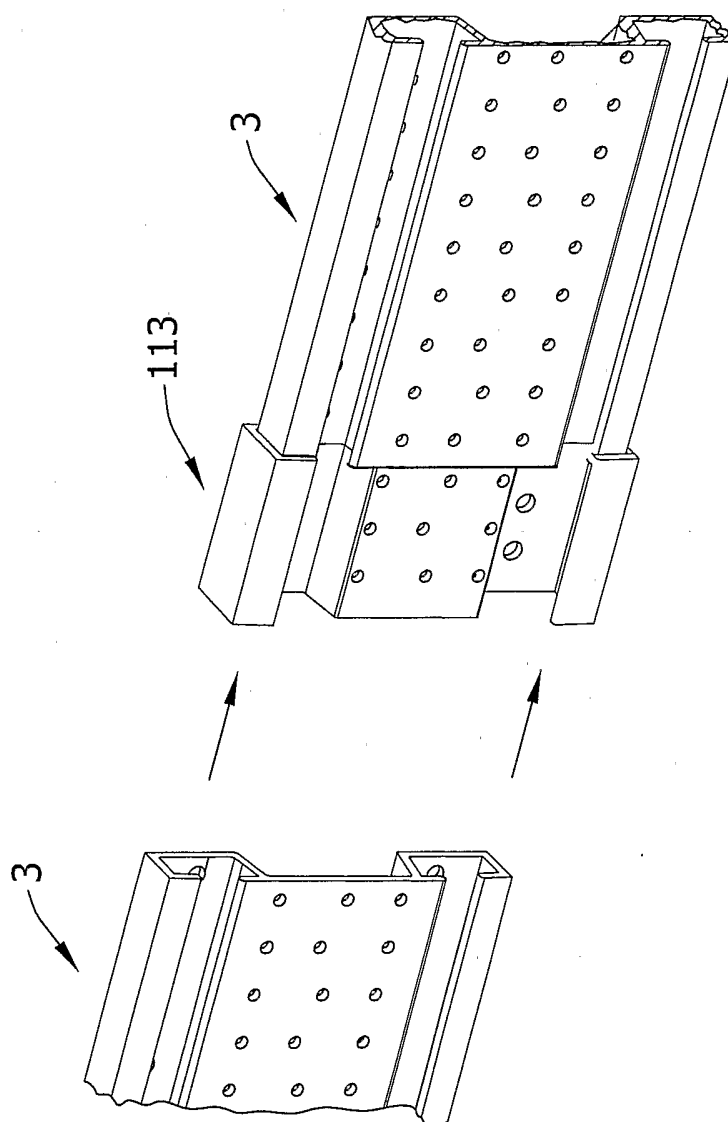

FIG. 3

FIG. 3A

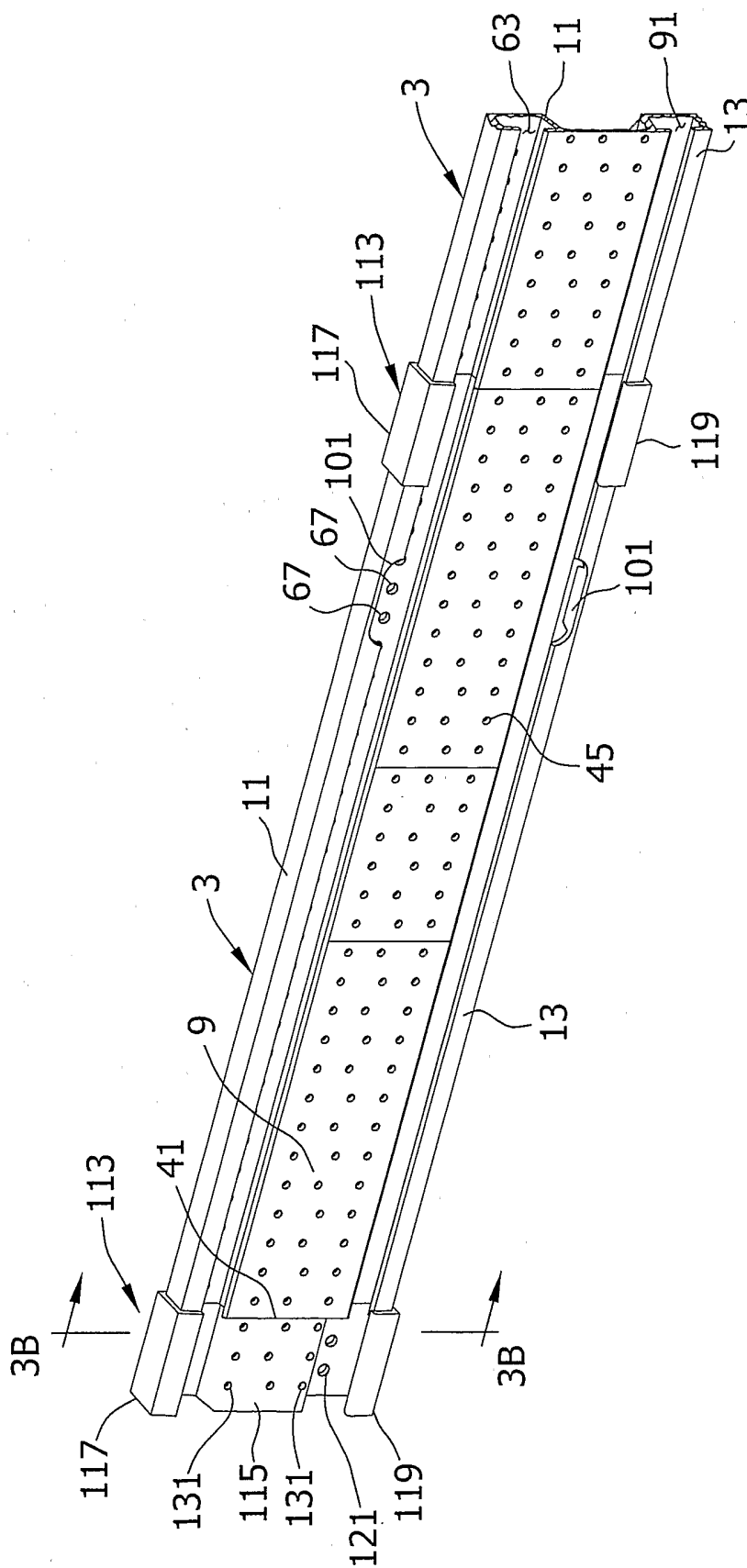

FIG. 3B

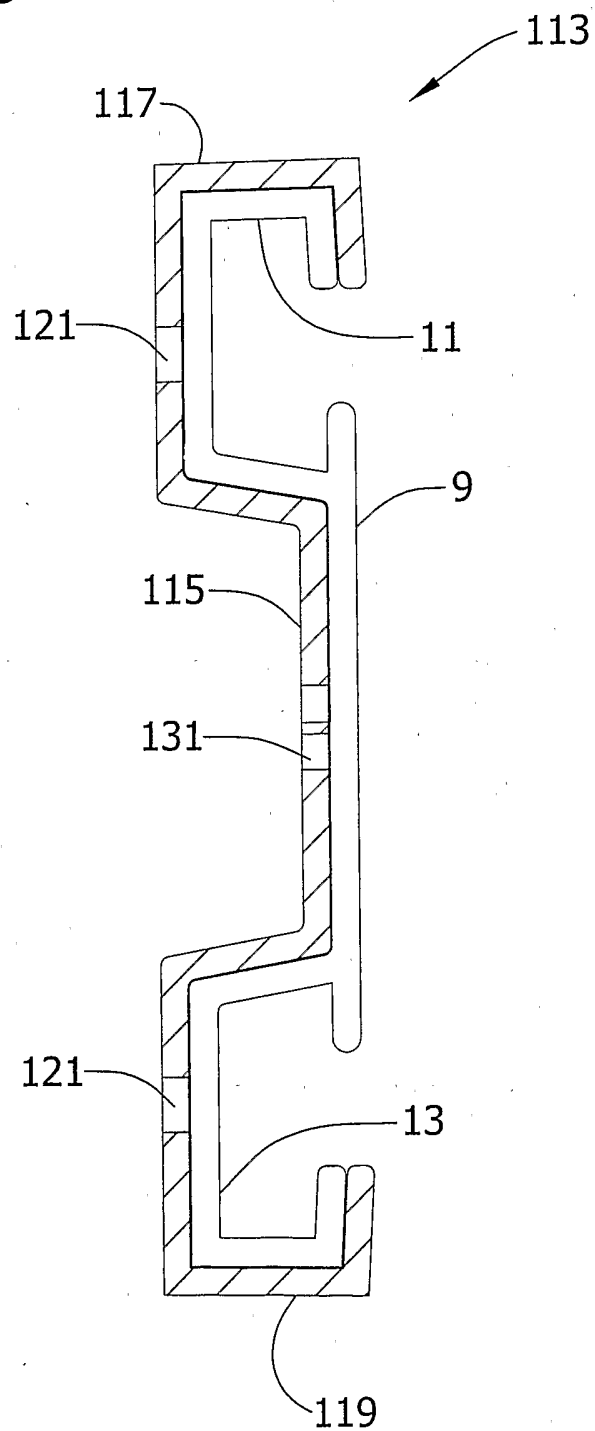

FIG. 4

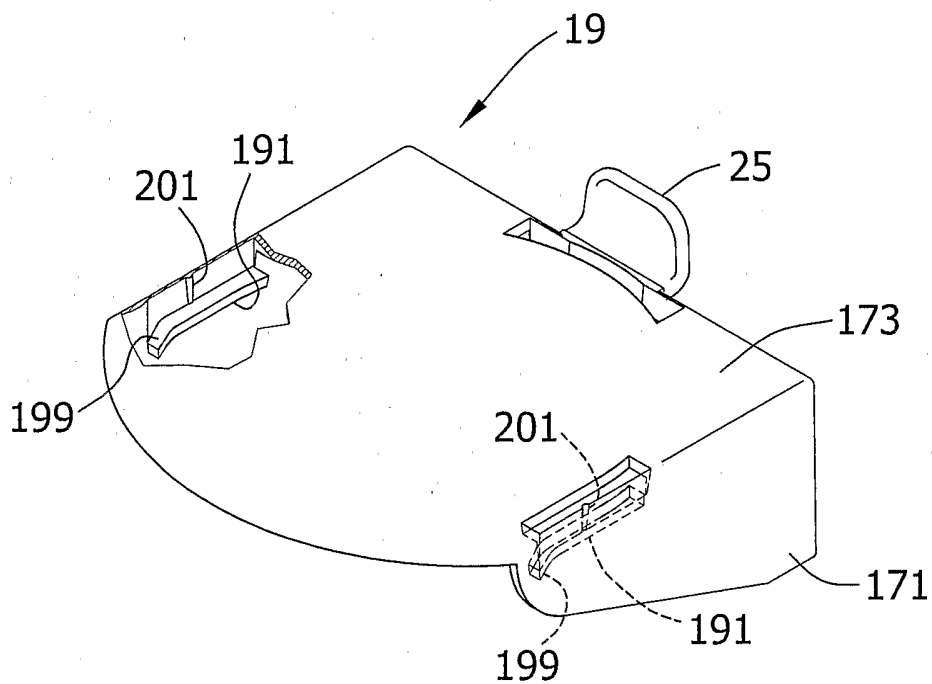

FIG. 5

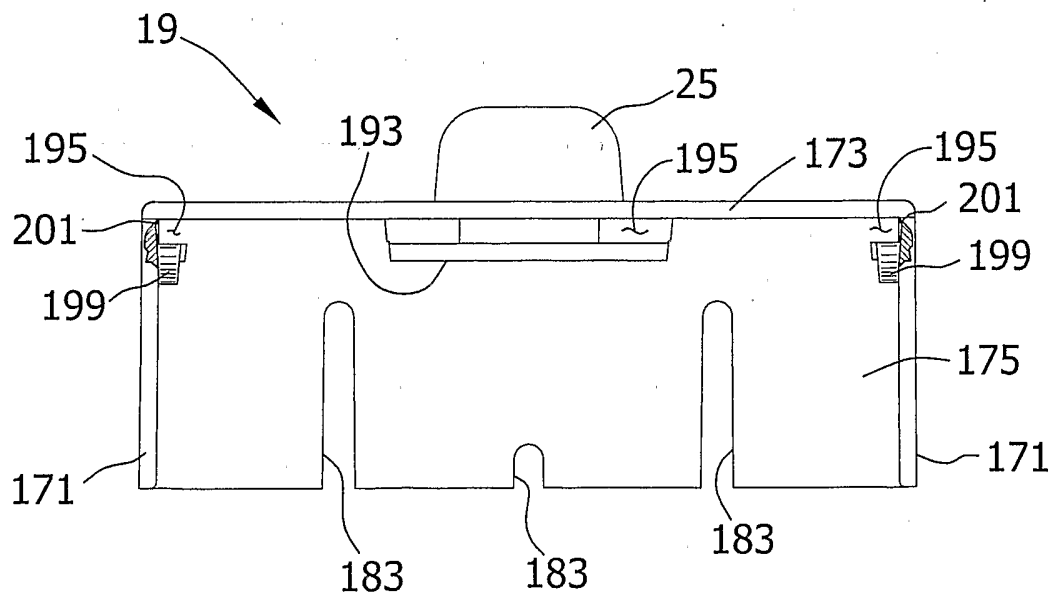

FIG. 7

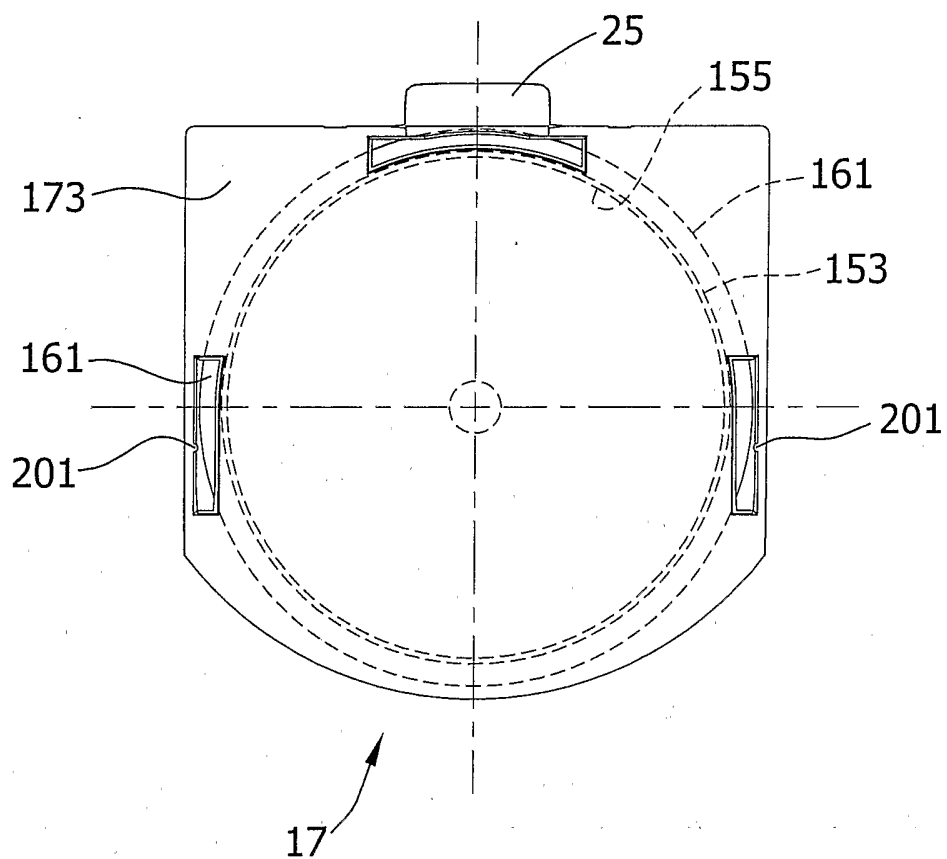
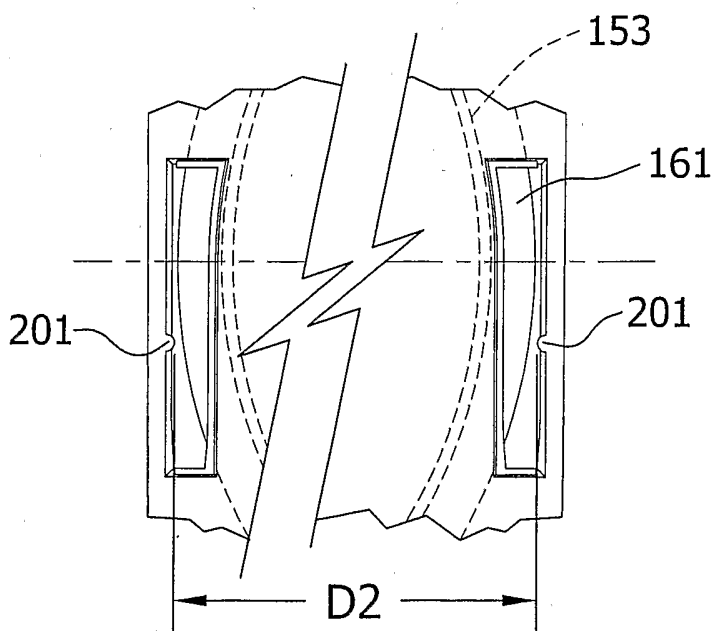
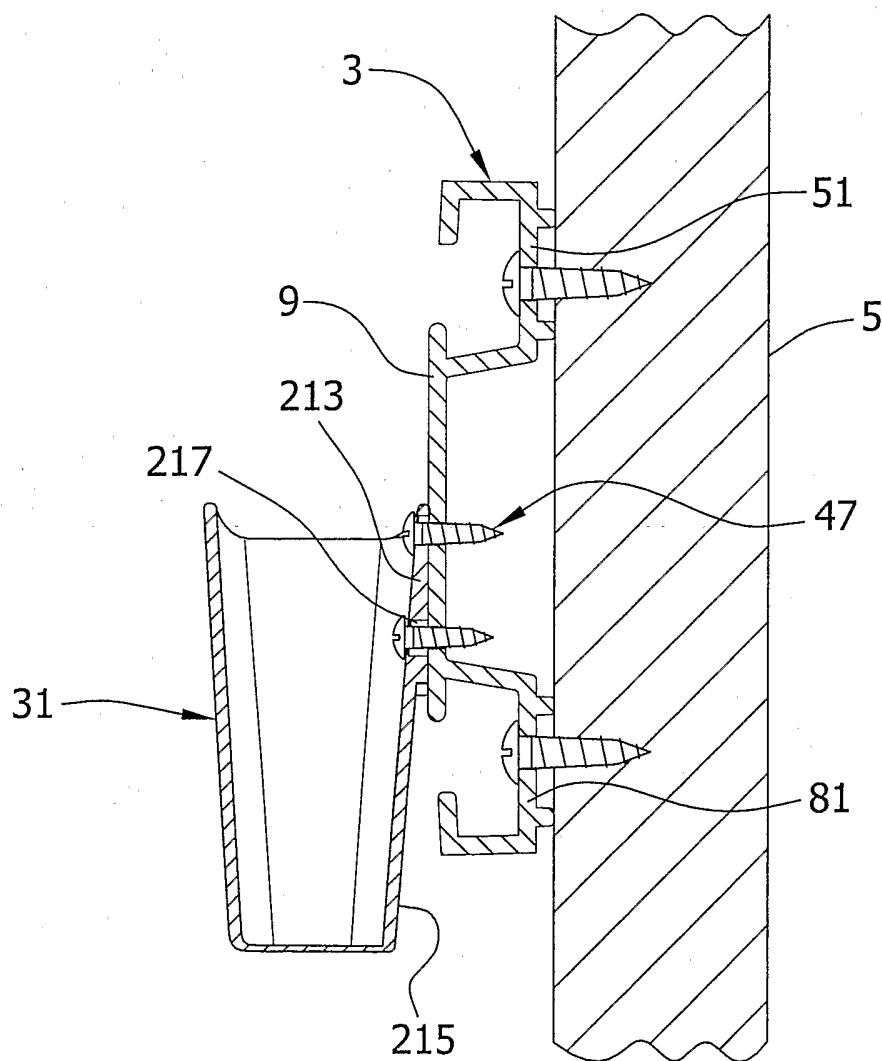

FIG. 7A



9/23

FIG. 8



10/23

FIG. 9

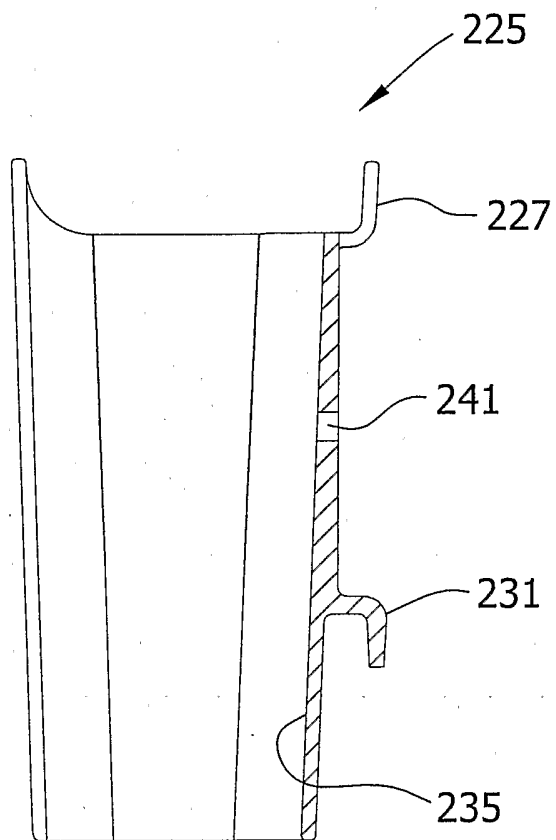

11/23

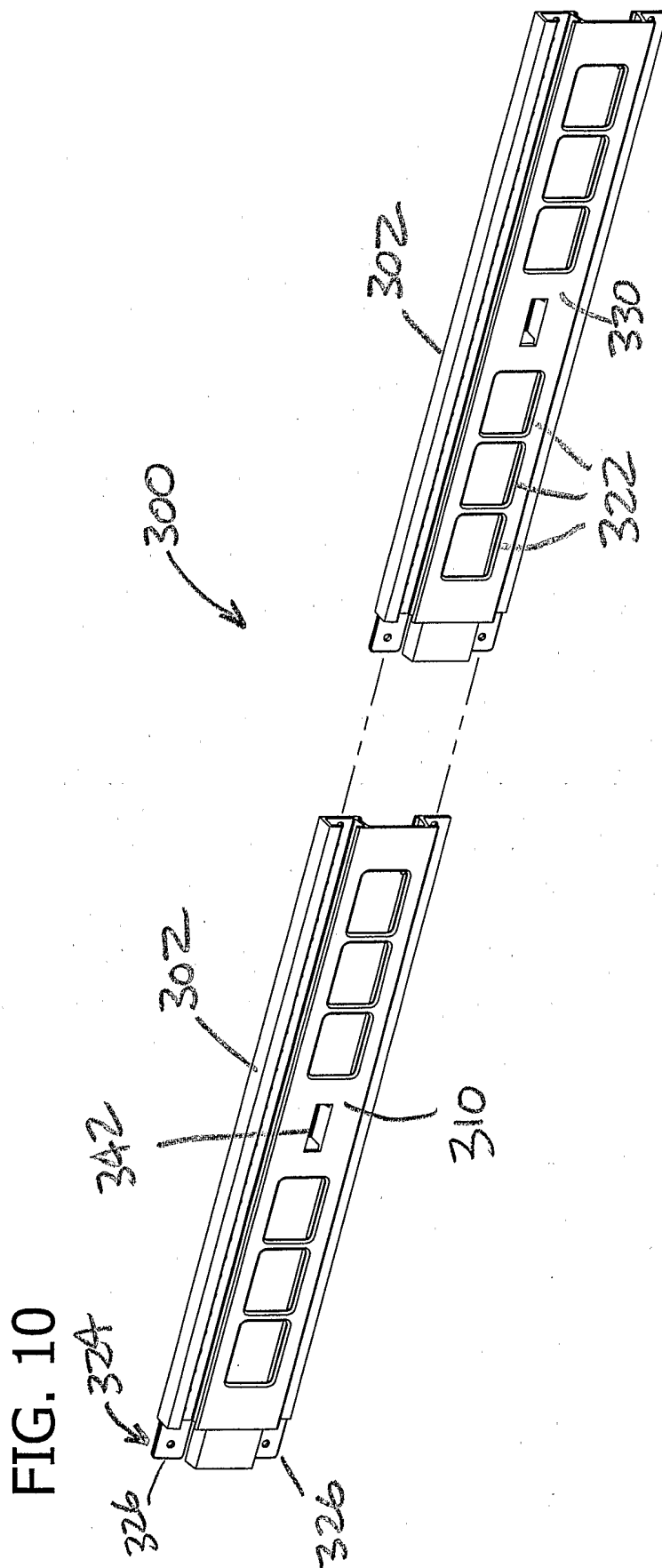

FIG. 11

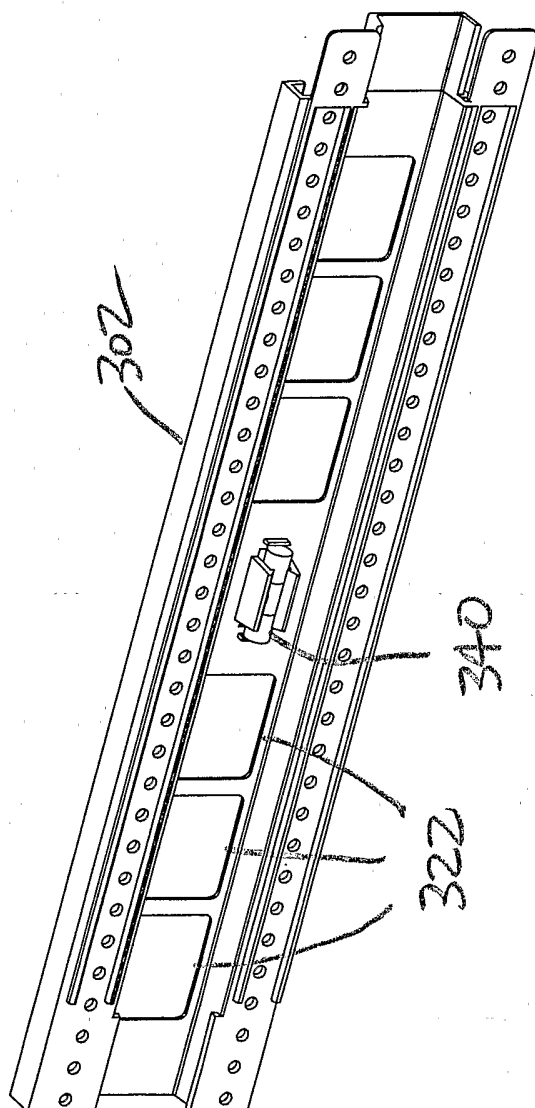
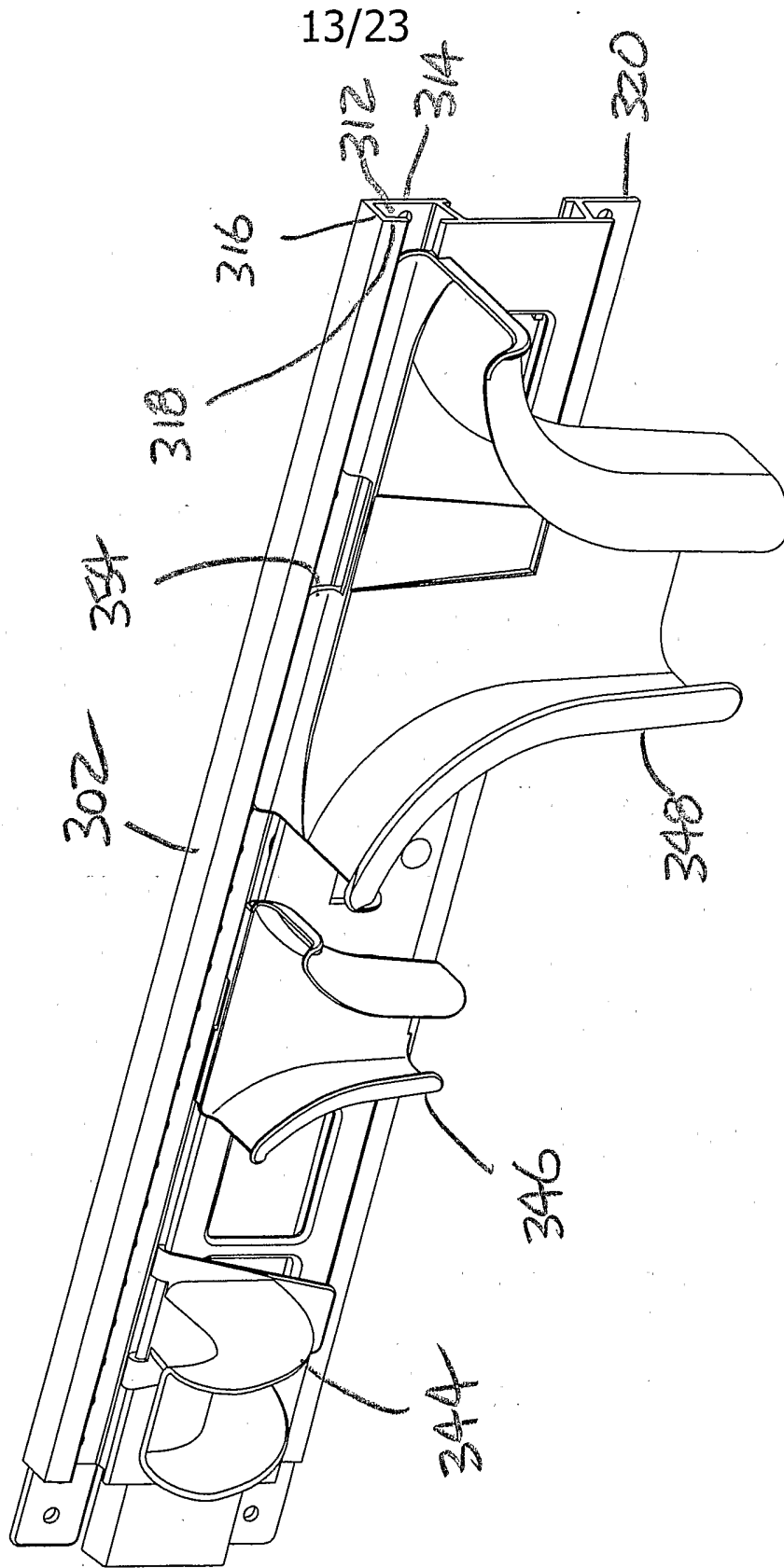

FIG. 12



14/23

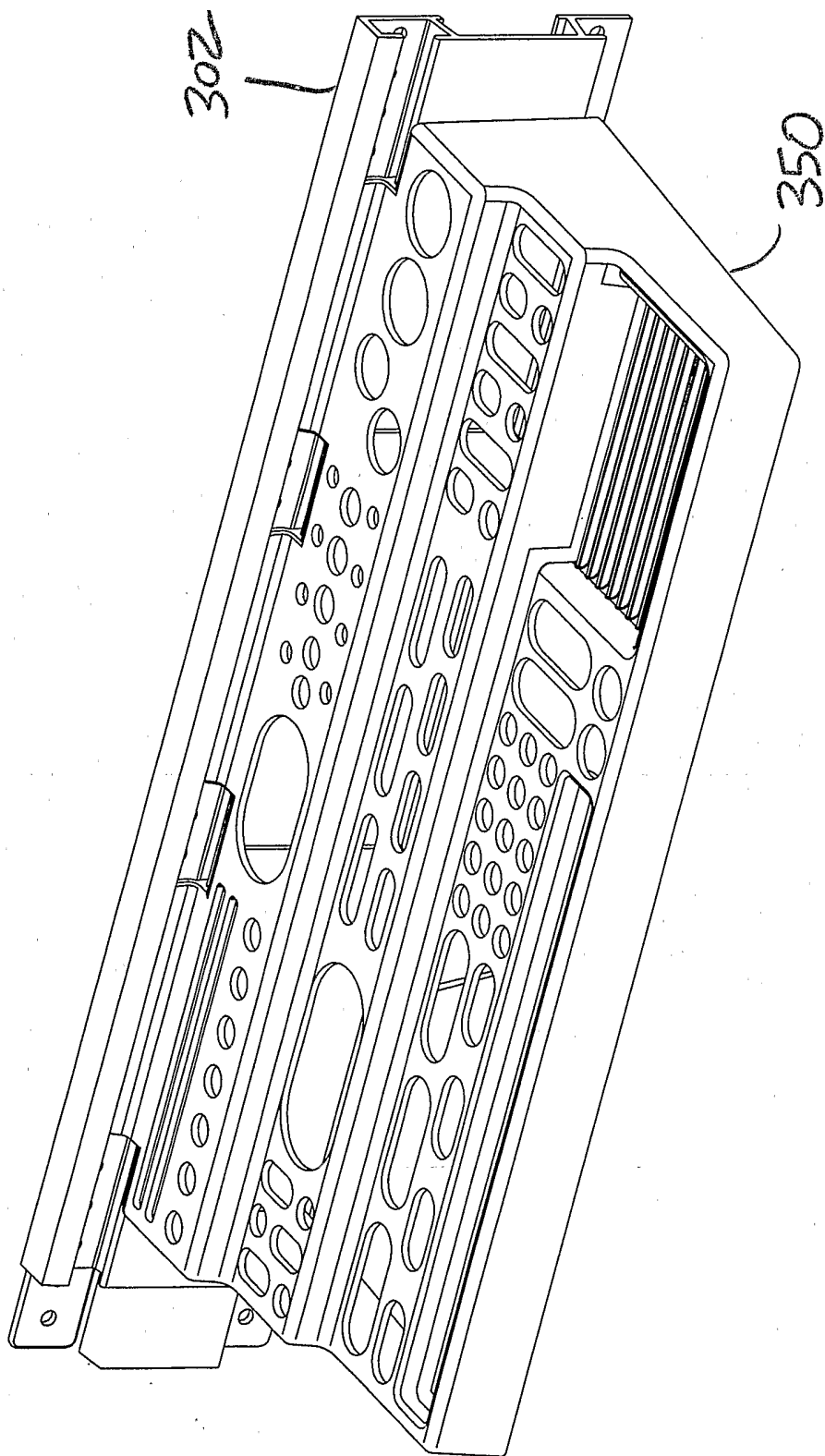

FIG. 13

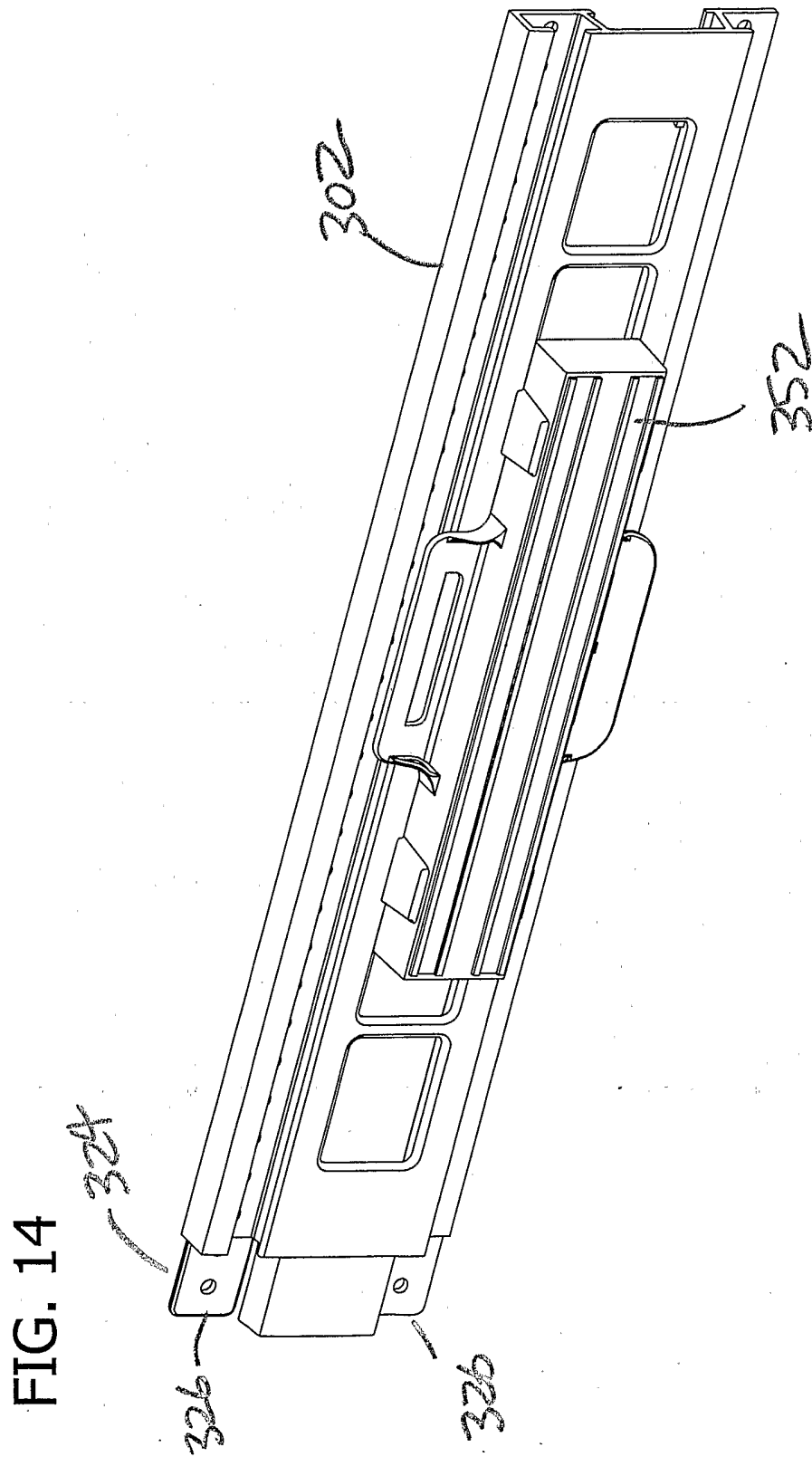

FIG. 15

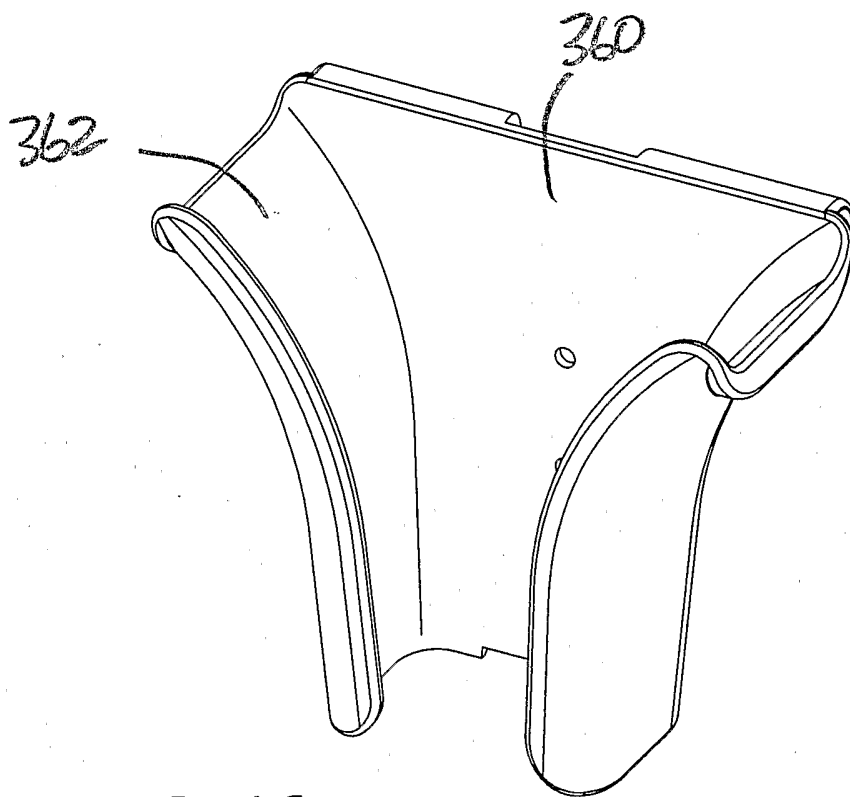

FIG. 16

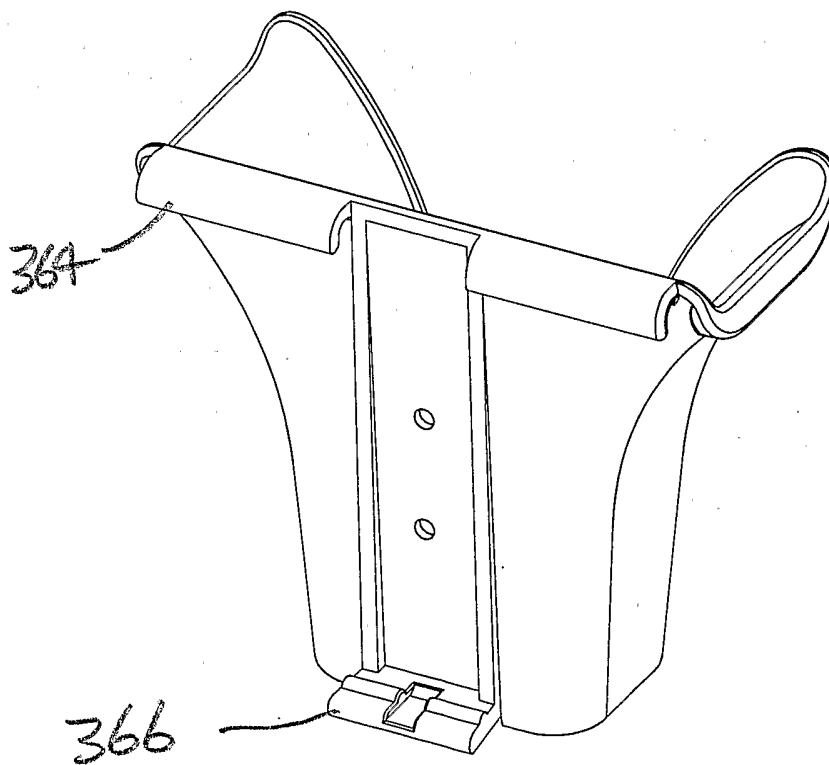

FIG. 17A

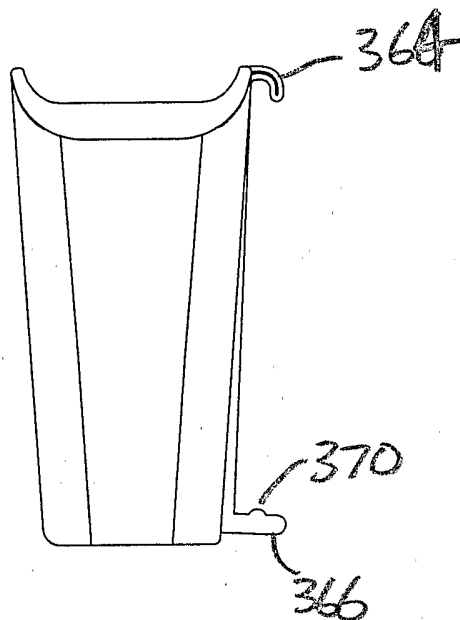

FIG. 17B

FIG. 17C

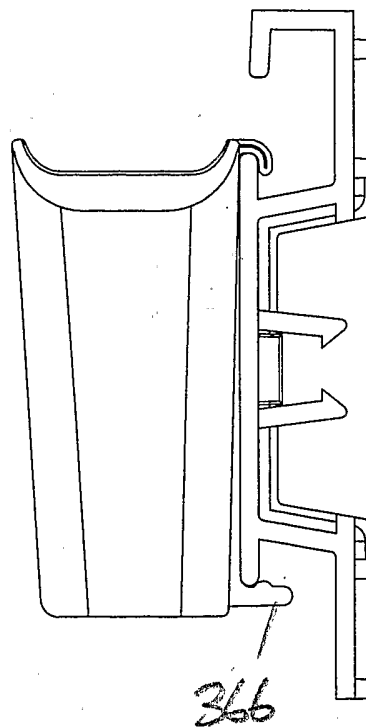
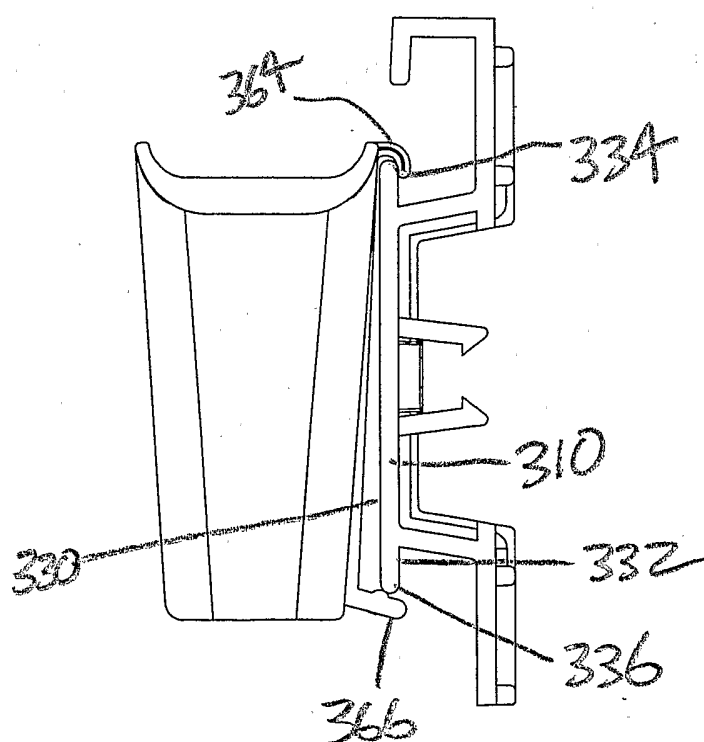

FIG. 18

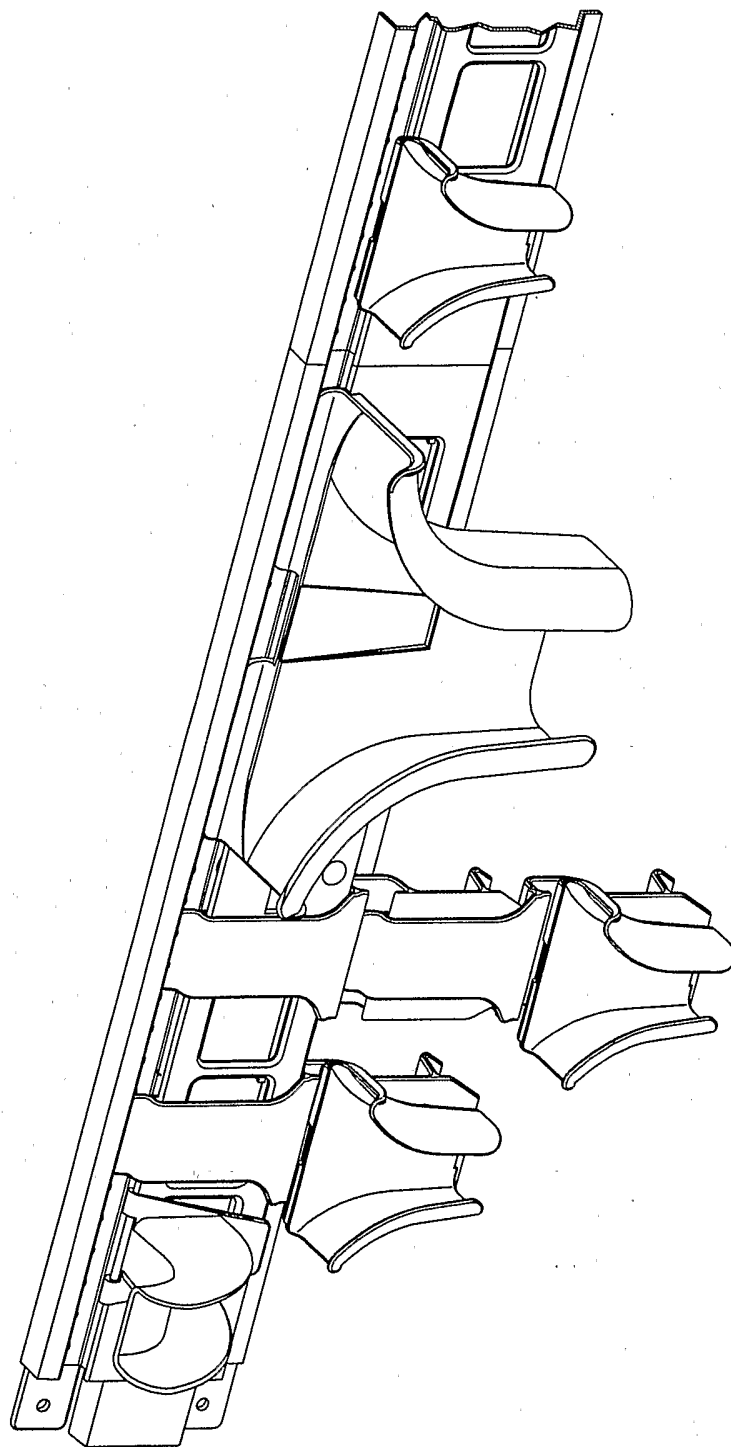

FIG. 19

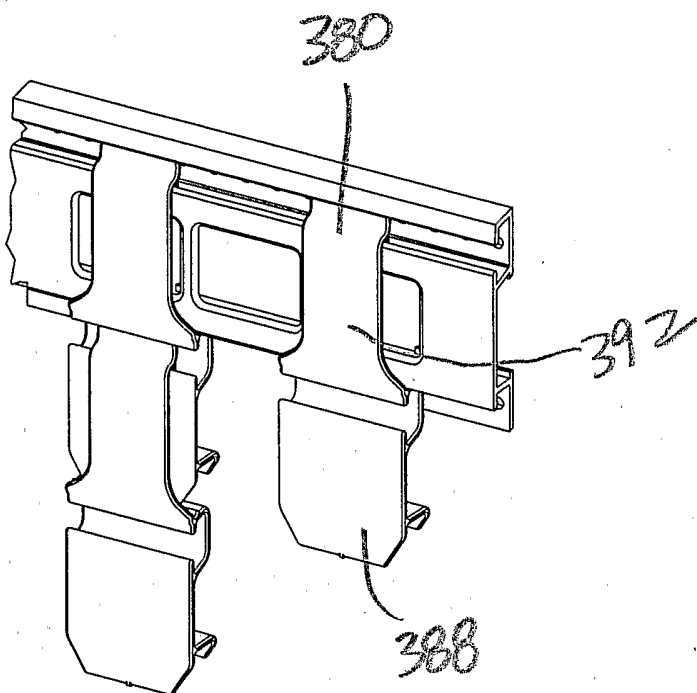

FIG. 20A

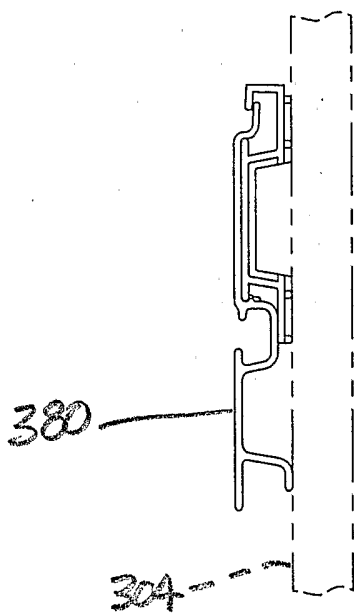

FIG. 20B

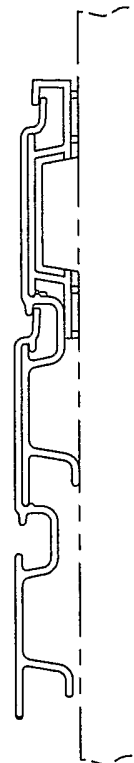

FIG. 21

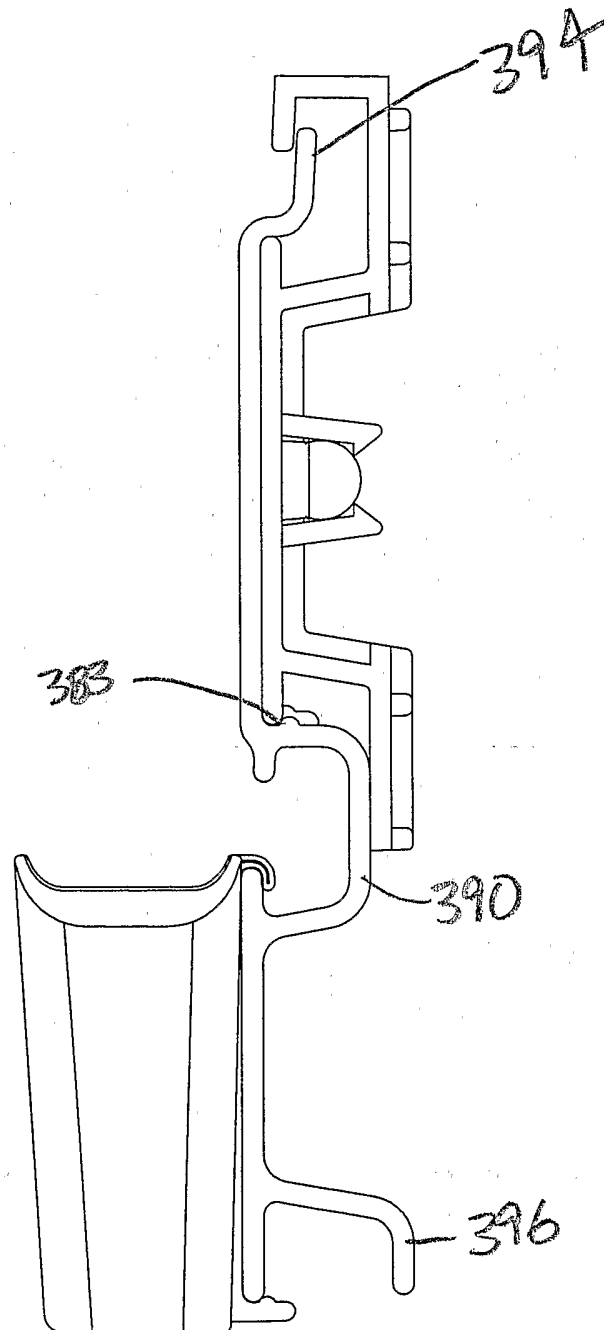

FIG. 22A

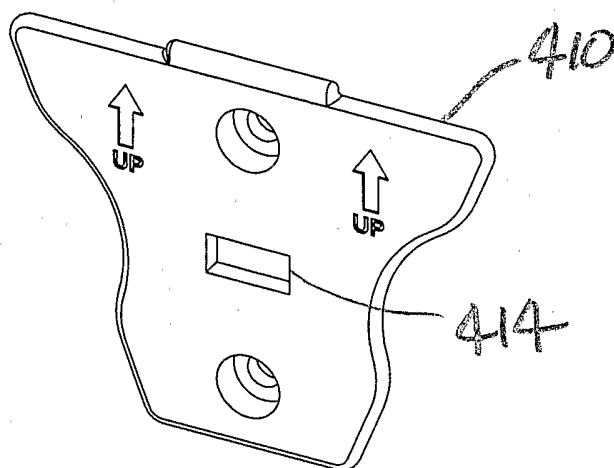

FIG. 22B

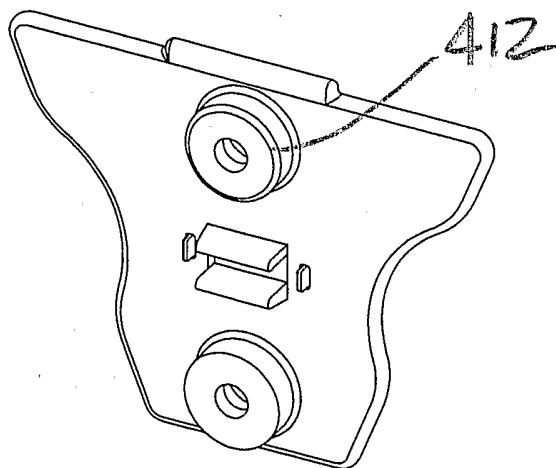

FIG. 22C

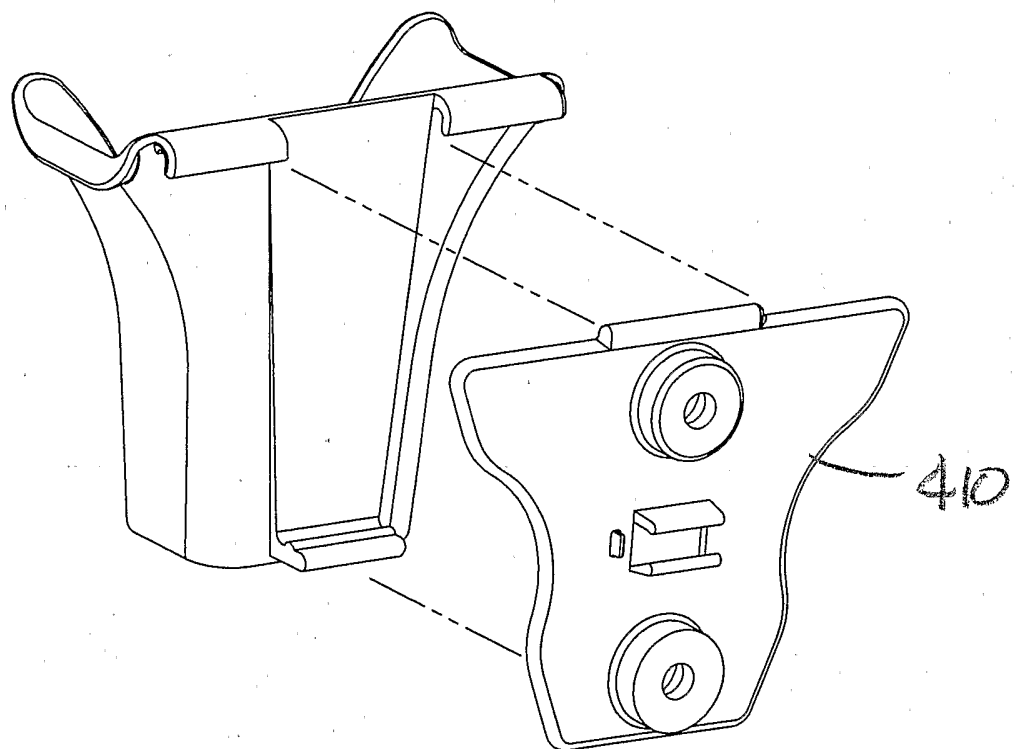

FIG. 23A

FIG. 23A

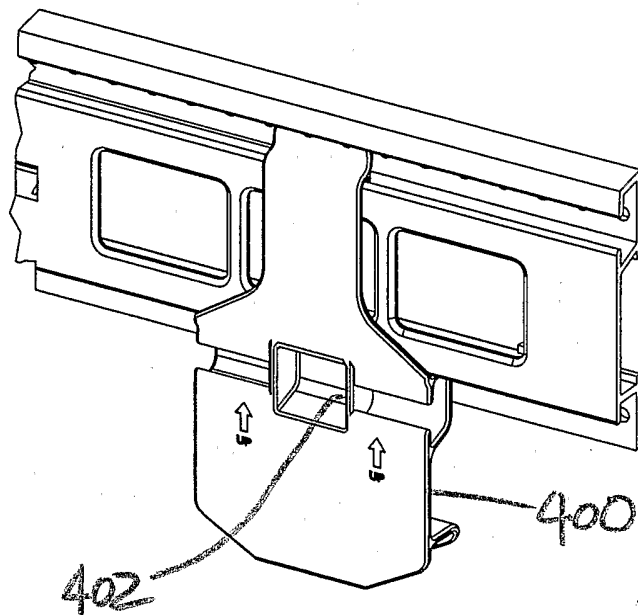

FIG. 23B

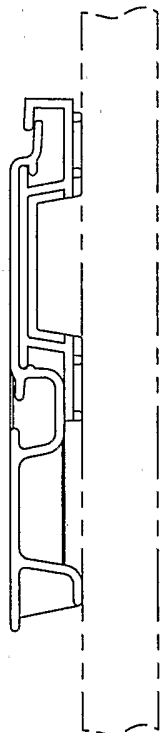

FIG. 23C

