



- (51) **International Patent Classification:**
A61M 25/09 (2006.01) *B29C 70/52* (2006.01)
A61L 31/12 (2006.01)
 - (21) **International Application Number:** PCT/IB2012/052933
 - (22) **International Filing Date:** 11 June 2012 (11.06.2012)
 - (25) **Filing Language:** English
 - (26) **Publication Language:** English
 - (30) **Priority Data:** 11171149.5 23 June 2011 (23.06.2011) EP
 - (71) **Applicant (for all designated States except DE, US):** **KONINKLIJKE PHILIPS ELECTRONICS N.V.** [NL/NL]; Groenewoudseweg 1, NL-5621 BA Eindhoven (NL).
 - (71) **Applicant (for DE only):** **PHILIPS INTELLECTUAL PROPERTY & STANDARDS GMBH** [DE/DE]; Lübeckertordamm 5, 20099 Hamburg (DE).
 - (72) **Inventor; and**
 - (75) **Inventor/Applicant (for US only):** **WEISS, Steffen** [DE/DE]; c/o High Tech Campus Building 44, NL-5656 AE Eindhoven (NL).
 - (74) **Agents:** **VAN VELZEN, Maaïke, M.** et al.; High Tech Campus, Building 44, NL-5656 AE Eindhoven (NL).
 - (81) **Designated States (unless otherwise indicated, for every kind of national protection available):** AE, AG, AL, AM, AO, AT, AU, AZ, BA, BB, BG, BH, BR, BW, BY, BZ, CA, CH, CL, CN, CO, CR, CU, CZ, DE, DK, DM, DO, DZ, EC, EE, EG, ES, FI, GB, GD, GE, GH, GM, GT, HN, HR, HU, ID, IL, IN, IS, JP, KE, KG, KM, KN, KP, KR, KZ, LA, LC, LK, LR, LS, LT, LU, LY, MA, MD, ME, MG, MK, MN, MW, MX, MY, MZ, NA, NG, NI, NO, NZ, OM, PE, PG, PH, PL, PT, QA, RO, RS, RU, RW, SC, SD, SE, SG, SK, SL, SM, ST, SV, SY, TH, TJ, TM, TN, TR, TT, TZ, UA, UG, US, UZ, VC, VN, ZA, ZM, ZW.
 - (84) **Designated States (unless otherwise indicated, for every kind of regional protection available):** ARIPO (BW, GH, GM, KE, LR, LS, MW, MZ, NA, RW, SD, SL, SZ, TZ, UG, ZM, ZW), Eurasian (AM, AZ, BY, KG, KZ, RU, TJ, TM), European (AL, AT, BE, BG, CH, CY, CZ, DE, DK, EE, ES, FI, FR, GB, GR, HR, HU, IE, IS, IT, LT, LU, LV, MC, MK, MT, NL, NO, PL, PT, RO, RS, SE, SI, SK, SM, TR), OAPI (BF, BJ, CF, CG, CI, CM, GA, GN, GQ, GW, ML, MR, NE, SN, TD, TG).
- Published:**
— with international search report (Art. 21(3))

(54) **Title:** COMPOSITE FIBER GUIDEWIRES

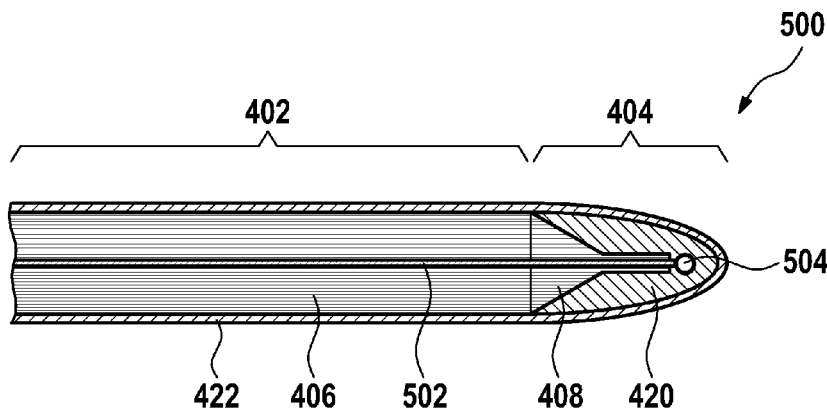

FIG. 5

(57) **Abstract:** A guide wire (400, 500, 600, 700, 800, 900, 1000, 1200, 1300) is adapted for use in magnetic resonance imaging systems. The guide wire has a shaft region (402) and a distal tip region (404). The shaft region comprises a composite shaft (406) comprising reinforcing fibers aligned with a length extension (403) of the shaft region. The fibers extend at least partially into the distal tip region. The fibers form a taper (410) within the distal tip region. The distal tip region comprises a sensor (504, 604, 702, 704, 804, 904, 1006, 1008). The shaft comprises a cable (502, 602, 702, 704, 802, 902, 1002, 1004). The cable is connected to the sensor.



COMPOSITE FIBER GUIDEWIRES

TECHNICAL FIELD

The invention relates to guidewires for guiding a catheter or used stand-alone for in-body sensing, in particular to guidewires that are suitable to be guided using magnetic resonance imaging.

5

BACKGROUND OF THE INVENTION

Guidewires are mostly used to guide catheters. Standard guidewires used in interventional X-ray are passive devices made from conductive materials, mostly metals. They are easily visualized in X-ray projections and CT by their radio-opacity due to metal contents. Active guidewires are important as well in clinical practice. The use of active guidewires for measurement of pressure, temperature, and flow is common in interventional X-ray.

10

In magnetic resonance imaging, a large magnetic field is used to align the nuclear spins of atoms as part of the procedure for producing images within the body of a subject. Magnetic resonance imaging is typically used to map the location of protons, such as those in a water molecule, within a subject. Magnetic resonance imaging is much better than X-ray techniques such as CT at imaging soft tissues and showing the detailed anatomical structures of soft tissues. However, the large magnetic field and radio-frequency signals used for magnetic resonance imaging prevents the use of some materials and electronics during a magnetic resonance imaging scan.

15

20

SUMMARY OF THE INVENTION

The invention provides for a guidewire, a catheter system, and a method of manufacturing a guidewire for a catheter in the independent claims. Embodiments are given in the dependent claims.

25

A difficulty with integrating a sensor into a guidewire is that active guidewires would contain long conductors for wiring which may cause RF-heating problems in the guidewire. Embodiments of the invention may address the problem and others with a guidewire constructed from a composite shaft with fibers aligned with the length of the shaft. The fibers have a low electrical conductivity and a low magnetic susceptibility. The fibers may for

30

instance the fibers may be, but are not limited to: non-conductive and non-magnetic fibers, dielectric fibers, glass fibers, carbon fibers, and aramid fibers. The composite shaft is magnetic resonance imaging compatible. A cable may be integrated into the composite shaft or attached to an outer surface of the shaft. For example, the cable may be a fiber optic cable or a resistive wire cable. The composite shaft may for instance be a fiber-reinforced core that may be co-pultruded with such wires/signal fibers, their connection to active components / sensors in the tip. Both types may be compatible with magnetic resonance imaging. This enables a sensor to be incorporated into the tip of a magnetic resonance imaging compatible guidewire.

Pultrusion as used here encompasses a continuous process for manufacture of composite materials. The composite material may have a constant cross-section. A pultrusion process may function by embedding fibers in a resin which is then formed with the fibers. For example a resin such as a thermosetting polymer may be used in conjunction with a heated die to form the composite material.

In one aspect the invention provides for a guidewire. In some embodiments the guidewire is adapted for guiding a catheter. In other embodiments the guidewire is adapted for use independent of a catheter. The guidewire has a shaft region and a distal tip region. The shaft region comprises a composite shaft comprising fibers aligned with a length extension of the shaft region. In some embodiments the fibers may extend along the entire length of the composite shaft. The fibers of the composite shaft extend at least partially into the distal tip region.. This allows a surgeon to better manipulate the guidewire and steer it and it prevents vessel injury. The distal tip region comprises a sensor. The shaft region comprises a cable. The cable for instance may be attached to an outer surface of the composite shaft or the cable may be embedded into the composite shaft. The cable is connected to the sensor.

The cable enables the sensor to be used for performing a measurement with the sensor.

This embodiment may have several advantages. The construction of the guidewire using the composite shaft comprising low conductivity and low magnetic susceptibility fibers, such as dielectric fibers, enables the guidewire to be used in a magnetic resonance imaging system. For instance a physician may use the magnetic resonance imaging for guiding the use of the guidewire. This is advantageous because ionizing radiation is not needed to see the position of the guidewire. In addition use of magnetic resonance imaging enables soft tissues to be better imaged. The incorporation of the sensor into the distal tip region enables vital measurements to be made with the guidewire when it has been inserted

or when the catheter is being used. A portion of the fibers is extending into the distal tip regions allows the flexibility of the distal tip region to be controlled or adjusted with respect to the flexibility of the shaft region. In this way guidewires which have the appropriate flexibility in the distal tip region may be designed.

5 In another embodiment the shaft region and the distal tip region are enclosed within a coating. The coating may for instance, but is not limited to, be a bio-compatible coating. The use of the coating is beneficial because it may be coated such that the surface of the guidewire is smooth which enables it to be inserted into a subject. The use of a bio-compatible coating is beneficial because it reduces the chance that the guidewire will cause
10 irritation or a reaction by the subject, e.g. formation of blood clots at the surface of the guide wire.

 In another embodiment the cable is within the composite shaft. For instance when the composite shaft is manufactured the cable may be built directly into the composite shaft. This may be advantageous because the composite shaft protects the cable.

15 In another embodiment the cable is a fiber optic cable. This may be beneficial because the fiber optic may be incorporated directly into the composite shaft. For instance if the composite shaft is manufactured using a pultrusion process the fiber optic can be incorporated directly into the composite shaft during manufacturing. The composite shaft will provide an excellent protection of the fiber optic cable with minimal weight and size.

20 In another embodiment the sensor is a thermometer. The thermometer is a sensor which is connected to the fiber optic cable or a resistive wire. The thermometer sensor may also be a part of the optical fiber. This enables the temperature at the distal tip region to be measured without the use of wires and is therefore more magnetic resonance imaging compatible.

25 In another embodiment the sensor is an accelerometer attached to the fiber optic cable. The use of a fiber optic accelerometer enables the measurements of acceleration in the distal tip region without the use of wires.

 In another embodiment the sensor is a pressure sensor. The pressure sensor is attached and operated by the fiber optic cable. The use of a fiber optic cable with a pressure
30 sensor is beneficial because the pressure may be measured in the distal tip region without use of wires.

 In another embodiment the sensor is an optical reflection spectrum sensor. The fiber optic cable may have one or more than one fibers which make up the fiber optic cable.

For a single fiber light may be shown into a region of the subject and reflected light may be measured. This may be beneficial because the optical reflection properties of a tissue region surrounding the distal tip region may be measured.

5 In another embodiment the sensor is an optical reflection spectrum sensor attached to a fiber optic cable. The optical reflection spectrum sensor may use for instance one or two fiber optics to determine the optical reflection properties of tissue in the subject surrounding the distal tip region.

10 In another embodiment the sensor is an optical transmission spectrum sensor. Again one, two or more fibers may be in the fiber optic cable and may be used for measuring the optical transmission spectrum. This is also beneficial because optical transmission properties of tissue surrounding the distal tip region can be measured.

15 In another embodiment the sensor is an optical fluorescence spectrum sensor. For instance a single fiber may be used to illuminate tissue surrounding the distal tip region. The same fiber optic or a different fiber optic or fibers may be used to then channel the fluorescing light back to a spectrometer to measure the fluorescence. This may be useful for detecting and determining tissue properties in a region surrounding the distal tip region.

20 In another embodiment the fiber optic cable comprises two or more single core optical fibers. The fiber optic cable is the sensor. The fiber optic cable is a fiber optic positioning and/or shape sensor. The fiber optic cable may for instance be used as a sensor for a position and/or shape sensing based on Rayleigh scattering. Such a fiber optic sensor is disclosed in United States Patent Application publication US 2008/0212082 A1.

In another embodiment the single core optical fibers are used as a sensor for Bragg scattering strain-sensors to detect a deflection or the shape of the composite shaft.

25 In another embodiment the cable is attached to the composite shaft. For instance the cable may be attached to an outer surface of the composite shaft.

In another embodiment the cable attached to the composite shaft is a fiber optic cable.

30 In another embodiment the cable attached to the composite shaft is a resistive wire. The resistive wire in another embodiment may also be incorporated into the composite shaft. For instance, during a pultrusion process the cable may be incorporated into the composite shaft. The use of a resistive wire is beneficial because it enables the use of sensors which need a wire but the use of a resistive wire enables the wire to be used in a high rf field such as generated by a magnetic resonance imaging system.

In another embodiment the sensor is a temperature sensor. For instance the temperature sensor may be a thermocouple connected to two resistive wires.

In another embodiment the sensor is pressure sensor.

In another embodiment the sensor may be an electrophysiological potential sensor such as is used for ECG or electrocardiogram. The use of an electrophysiological potential sensor may be beneficial because the guidewire can be inserted near the region of a heart and measurements can be taken directly using the guidewire.

In another embodiment the composite shaft further comprises a first matrix material for binding the fibers together. The fibers in the distal tip region are connected with a second matrix material for binding the fibers. The flexibility of the second matrix material is higher than the first matrix material. This may be beneficial because the use of a different matrix material within the tip region may make the distal tip region of the guidewire more flexible. For instance when the wire is manufactured the matrix material of the composite may be removed in the distal tip region. The distal tip region may then be shaped and then re-glued or re-bonded together using the second matrix material. This method alone or a combination with tapering the tip of the distal tip region enables the design of more highly flexible distal tip regions.

In another embodiment the fibers form a taper within the distal tip region. The tapering of the fibers in the distal tip region may make the distal tip region more flexible

In another aspect the invention provides for a catheter system comprising a guidewire according to an embodiment of the invention and a catheter. The guidewire is configured for guiding the catheter. Catheters such as those already known in the art may be used with an appropriate guidewire according to the embodiment of the invention. This enables the design of a catheter system which is magnetic resonance compatible. The catheter system may be a catheter kit comprising a guide wire according to an embodiment of the invention and a catheter.

In another aspect the invention provides for a guidewire system comprising a guidewire according to an embodiment of the invention and sensor electronics or sensor optics. The sensor electronics or sensor optics are adapted to be connected to a proximal end of the guidewire. When connected to the proximal end of the guidewire the sensor electronics or sensor optics are connected to the cable. This enables to drive and/or receive data from the sensor. For connection of the cable to the electronics or optics, the matrix material may be

removed at the proximal end as described above for connection of the the distal end of the cable to the sensor.

In another aspect the invention provides for a method of manufacturing a guidewire for a catheter. The method comprises the step of receiving a composite shaft comprising fibers aligned with the length extension of the composite shaft. The composite shaft comprises a cable. The method further comprises the step of shaping the distal tip region of the composite shaft into a taper. The distal tip region may be shaped into a taper in a variety of different ways. For instance the distal tip region may be ground and/or the distal tip region may be formed by cutting individual fibers which make up the composite shaft within the distal region.

In still yet other embodiments the matrix material is removed from the distal tip region of the composite shaft, the distal tip region is shaped and then the distal tip region is then bound together using an additional binding agent or glue. The method further comprises the step of connecting a sensor to the cable. The cable is connected to the sensor to allow a sensor measurement or reading to be performed at a proximal end of the guide wire. For instance the cable may be a fiber optic or it may be a resistive wire. An embodiment of this invention may be beneficial because a magnetic resonance compatible guidewire may be constructed. Another potential benefit is that the tapered distal tip region of the composite shaft allows the precise design of the desired flexibility for the distal tip region. The method further comprises the step of connecting a sensor to the cable.

In another embodiment the method further comprises the step of coating the shaft region and the distal tip region with a coating. The coating may in some embodiments be a bio-compatible coating.

In another embodiment the method further comprises forming the composite shaft with a pultrusion process. The shaft could then be cut to the required length. The distal tip region of the composite shaft may be is provided by cutting it to length. The tip may be then formed into a taper-shape.

In some embodiments, the cable is incorporated into the composite shaft during the pultrusion process. For instance a large spool of the composite shaft could be manufactured at one time. Incorporating the cable into the composite shaft may be beneficial because it may make the catheter more easy and cost effective to manufacture. Incorporating the cable into the composite shaft may also make the cable better protected.

In other embodiments the composite shaft is pultruded, but the cable is attached to an exterior surface of the composite shaft.

In another embodiment the method may comprise the step of coating the shaft region and the distal tip region with a coating. For instance the coating may be a bio-
5 compatible coating.

In another embodiment the fiber optic cable comprises two or more single core optical fibers. The fiber optic cable is the sensor. The fiber optic cable is a fiber optic position and/or shape sensor.

In another embodiment the method further comprises attaching the cable to an
10 exterior surface of the composite shaft. For instance the cable may be glued or otherwise attached to a surface of the composite shaft.

In another embodiment the cable is a fiber optic cable.

In another embodiment the cable is a resistive wire.

In another embodiment the distal tip region is at least partially shaped by
15 grinding. The composite material which makes up the composite shaft may be ground into a taper-shape. This may be beneficial because it is an easy and cost effective way of shaping the distal tip region.

In another embodiment the composite shaft further comprises a first matrix material for binding the fibers together. The method further comprises the step of removing
20 the first matrix material at the distal tip region. For instance the distal tip region may be dipped into a solvent or other material which dissolves or removes the first matrix material. This may be beneficial because it may provide better access to the cable which to attach to the sensor. It may also be beneficial because removing the first matrix material from the distal tip region may make the distal tip more flexible.

In another embodiment the distal tip region is at least partially shaped by
25 cutting a portion of the fibers. For instance once the first matrix materials have been removed from the distal tip region the individual fibers which make up the distal tip region may be cut.

In another embodiment the method further comprises the step of binding the
30 fibers in the distal tip with a second matrix material for binding the fibers. The flexibility of the second matrix material is higher than the first matrix material. This embodiment may be beneficial because it allows reconstruction of the composite material in the distal tip region with a more flexible matrix material. This may facilitate the manufacture of a guidewire which has a distal tip region which has a higher flexibility.

BRIEF DESCRIPTION OF THE DRAWINGS

In the following preferred embodiments of the invention will be described, by way of example only, and with reference to the drawings in which:

5 Fig. 1 shows a flowchart which illustrates a method according to an embodiment of the invention;

Fig. 2 shows a flowchart which illustrates a method according to a further embodiment of the invention;

10 Fig. 3 shows a flowchart which illustrates a method according to a further embodiment of the invention;

Fig. 4 illustrates a guidewire according to an embodiment of the invention;

Fig. 5 illustrates a guide wire according to a further embodiment of the invention;

15 Fig. 6 illustrates a guide wire according to a further embodiment of the invention;

Fig. 7 illustrates a guide wire according to a further embodiment of the invention;

Fig. 8 illustrates a guide wire according to a further embodiment of the invention;

20 Fig. 9 illustrates a guide wire according to a further embodiment of the invention;

Fig. 10 illustrates a guide wire according to a further embodiment of the invention;

25 Fig. 11 shows a flowchart which illustrates a method according to a further embodiment of the invention;

Fig. 12 illustrates a guide wire according to a further embodiment of the invention

Fig. 13 illustrates a guide wire according to a further embodiment of the invention.

30

DETAILED DESCRIPTION OF THE EMBODIMENTS

Like numbered elements in these figures are either equivalent elements or perform the same function. Elements which have been discussed previously will not necessarily be discussed in later figures if the function is equivalent.

5 Fig. 1 shows a flowchart which illustrates a method according to an embodiment of the invention. In step 100 a composite shaft is received comprising fibers and a cable. For instance the cable may be formed into the fiber composite or it may be attached to an outside surface of the composite shaft. Next in step 102 a distal tip region of the composite shaft is shaped into a taper. Shaping the distal tip region into a taper allows the flexibility of the distal tip region to be increased. Finally in step 104 a sensor is connected to the cable.

Fig. 2 shows a flow diagram which illustrates a method according to a further embodiment of the invention. In step 200 a composite shaft is received comprising fibers. Next in step 202 the distal tip region of the composite shaft is shaped into a taper by grinding the distal tip region. Next in step 204 a cable is attached to an exterior surface of the cable. For instance the cable may be a resistive wire glued or otherwise attached to the exterior surface of the cable. Finally in step 206 a sensor is connected to the cable.

Fig. 3 shows a flow diagram which illustrates the method according to a further embodiment of the invention. In step 300 a composite shaft is formed using a pultrusion process which incorporates a cable into a fiber composite shaft. Next in step 302 the composite shaft is received. For instance the composite shaft may be formed in a longer length and then cut to length. Next in step 304 the matrix material is removed from the distal tip region of the fiber composite shaft. The matrix material may for instance be the glue or other material which holds the fibers together. Next in step 306 a portion of the fibers in the distal tip region are cut to form a taper. In some embodiments the fibers may also be ground or ground prior to removing the matrix material. Next in step 308 a sensor is connected to the cable. Next in step 310 the shaft region and the distal tip region are coated with a coating. The coating for instance may be a bio-compatible coating.

Fig. 4 shows an example of a guidewire 400 according to an embodiment of the invention. In this particular embodiment the cable and the sensor are not shown. Fig. 4 illustrates the structure of a guidewire. Guidewire 400 comprises a shaft region 402 and a distal tip region 404. The arrow labeled 403 illustrates the length extension running along the length of the shaft region 402. Within the shaft region 402 the composite comprises fibers

aligned with the length extension 403 and a region of a first matrix material 406. In the distal tip region 404 the fibers are again aligned with the length extension 403 but in this case may be formed with a second matrix material or glue 408. In some embodiments the second matrix material is equivalent or the same as the first matrix material. The composite material 408 has been ground down to a taper or shaped into a taper 410. The actual shape of the taper may be adjusted to adjust the floppiness or flexibility of the distal tip region 404. The overall length of the composite material 412 may be adjusted or changed in relation to the length of the taper 414. In many embodiments the length 414 of the taper 410 will be approximately 5 to 10 cm. In this case the guidewire is formed by a composite material of an outer diameter 416. The outer diameter will typically be 0.5 to 1 mm. The taper then narrows to a second diameter 418. In some embodiments the inner diameter 418 can be reduced to 0 and the taper 410 goes to a point. In other embodiments the length 412 and length 414 may be identical. In other embodiments the taper 410 may be a curved or other shaped surface. The taper 410 does not need to be cone shaped as is illustrated in Fig. 4.

Surrounding the tapered tip 410 is a tip section 420. Surrounding the tip section 420 is a coating 422. The coating in some embodiments may be a bio-compatible coating. The material of the tip section 420 may be identical with the coating 422 or it may be of another material. For instance it may contain one or more nitinol strands. The material of the tip section 420 can be chosen to give a desirable flexibility to the distal tip region 404. Fig. 4 has shown the overall structure of a guidewire. In the following Figs. various types of sensors and cables are incorporated into the prototype guidewire design shown in Fig. 4. The actual configuration of the guidewires shown in the following Figs. may be adapted or changed in accordance with the example shown in Fig. 4. Fig. 4 and other figures illustrating guide wires are not drawn to scale.

Guidewires are required for most vascular interventions. Standard guidewires are made from metals and cannot be used in MR due to MR-related RF heating. MR-guidewires that do not contain long conductive structures but instead consist of a PEEK plastic core and a fiber compound core have been proposed before. PEEK is hardly strong enough to realize guidewires with clinical performance especially at low diameters. A fiber compound consists of a multitude of thin fibers, which are embedded in and hold together by a plastic matrix material. The composite shaft comprising fibers may be a fiber compound. The process for production of the fiber compound is known as pultrusion and can be imagined as an extrusion process as performed for plastic tubing

together with a fiber bundle. Pultrusion similarly to extrusion may be performed as an endless process. The components (i.e., dielectric-fibers, matrix material type) and the parameters (i.e., temperature, pultrusion speed, pressure at nozzle) are adapted to produce a stiff guidewire core. A fiber compound may for example consist of consisting of 12 μ m thick
5 fibers embedded in a plastic matrix material.

Guidewires typically have a tip section with continuously increasing floppiness. This prevents injury of the intima and allows navigation into vessel branches. For fiber-reinforced guidewires, this raises the problems of creating a smooth transition from a relatively stiff fiber-reinforced main section to the floppy tip section and the realization of the
10 floppy section itself. A floppy tip section may be constructed, for example, by shafting (gluing) a tip section made from nitinol as conventionally used to the main section made from the fiber-reinforced material.

A feature of some embodiments of the invention is to provide an MR-guidewire with a core that is completely made from fiber-reinforced material up to the tip
15 without the need for attachment of a separate tip section. Hence, the danger breaking off is abandoned. An even more important feature is that such a guidewire enables the integration and wiring of active components and sensors.

The introduction of active components or sensors into the tip and the change of mechanical parameters of the tip section cannot be achieved during the pultrusion process
20 of the fiber-reinforced core because pultrusion only works as an endless process.

In some embodiments It is therefore proposed to first remove the matrix material, or matrix material material, in the tip section of a guidewire core again after the core has been pultruded and cut to length. Then, active components are introduced and wired, and at last, the tip is rebuilt to realize a floppy tip section.

25 The matrix can be removed by any appropriate process or a combination of processes, including resolution by a solvent, thermal treatment if the matrix is a thermoplast, oxidative removal of the organic material in a wet process, or other chemical processes.

Partial or complete removal can be applied. Partial removal may leave a central inner section of the core intact and only outer fibers are exposed and re-embedded in a
30 softer matrix. This is efficient because the outer sections of the core contribute much more to the overall stiffness than the inner sections. An intact inner core may simplify the rebuilding process of the tip. Secondly, it may prevent breakage of the finished wire if there is a hard transition from original to new soft matrix material.

As a preparation step for removal or as an alternative to removal the matrix may be weakened or modified by chemical reactions, by ionizing or UV radiation, by mechanical treatment or other types of treatment. Weakening may be used to achieve the increased floppiness of the tip section directly.

5 If the fibers of the tip section are partially or completely exposed, objects can be incorporated into the tip section. In this stage, any type of sensors (pressure, temperature, flow, acceleration, can be introduced and wired to respective wires or optical fibers. Such wires or fibers preferably have been co-pultruded in the endless process. For intrinsic fiber-optic sensors wiring is not required, because the fiber itself represents the sensor. However, 10 intrinsic sensors may have to be prepared for access to the quantity to be measured, which may be hard to realize in the initial pultrusion process. An obvious example is an intrinsic fiber-pressure sensor. It will not work being rigidly embedded in the fiber-compound surrounded by matrix and other fibers as after the pultrusion. Matrix removal enables to single out such a fiber-sensor from the fiber bundle and to position and prepare it within the 15 tip section such that it has access to surrounding pressure, which may even require to apply a window in the coating. Another example is the preparation of an optical fiber that will be used to transmit / collect light from tissue for illumination/ablation or optical signal reception of some form. Such a fiber may be located to the outside of the bundle, embedded in the coating near the surface or below an optical window, equipped with a microprism or 20 microlens.

Co-pultruded electrical wires may singled-out and connected to electrical sensors. Similarly to wiring of wires to sensors in the tip, matrix removal may be used at the proximal end of the device to connect wires or fibers to respective read-out hardware.

25 Finally, the same or a different, preferable softer matrix material (matrix material) is applied to rebuild the matrix around the exposed fibers and other components by compression molding or a similar process. The fibers may be trimmed before refixation similarly to the shape of the nitinol section or to another appropriate shape facilitating a tip with increasing floppiness. Additional components for mechanical reinforcement may be added, e.g. one or several thin nitinol wires.

30 The different matrix material in the tip section may not only be used to change the mechanical properties but also to realize a different dotation with substances that provide visibility in MRI or X-ray and CT.

Fiber-optic shape sensing may be included as one form of sensors

Optical methods are used to measure the strain in a set of fibers which are rigidly attached to each other, from which the shape in 3D and also the temperature profile can be calculated. Two principles have been used to measure fiber-shape, fiber-bragg-gratings and characteristic Rayleigh scatter patterns.

5 Highly resistive wires may be included into core or between core and coating. Such wires are known to prevent MR-induced RF heating from their use in catheters. They can be used for temperature sensing when fitted to a thermistor as well as for sensing of intracardiac electrophysiology signals.

 Pressure sensor, e.g. fiber-optic with 0.2mm outer diameter of actual sensor
10 OPP-M by OPSENS, a MEMS-based fiber optic pressure sensor designed for human and animal physiological pressure measurements.

 These miniature 0.25 mm OD and 0.40 mm OD sensors are intended for use in catheters, guide-wires or other devices enabling minimally invasive physiology pressure measurement. Its novel patent pending design eliminates moisture-induced drift and
15 minimizes thermal zero shift.

 Various companies have commercialized fiber-optic temperature sensors, also for integration into intravascular devices.

 An accelerometer may also be operated via fiber-optics and therefore used as a sensor in a guidewire.

20 For the matrix (matrix material) and coating materials Thermoplasts (Polyurethane, polypropylene, ...) as well as epoxies can be used. For a previous passive guidewire, Krueger et al used the matrix material epoxy in combination with fibers primarily optimized for 0.018-, 0.026-, and 0.032-inch shaping tools to allow for variable guidewire stiffnesses and sizes.

25 As coatings, polyurethanes (PU), polyether/amide block copolymers (PEBAX), polypropylene (PP) and other materials as for standard guidewires and catheters can be used.

 Fig. 5 shows a further embodiment of a guidewire 500 according to an embodiment of the invention. The embodiment shown in Fig. 5 is similar to the embodiment shown in Fig. 4. In this embodiment a cable 502 is shown as being integrated into the
30 composite shaft 406, 408. For instance the cable 502 may be a fiber optic or a resistive wire. At the end of the cable 502 is a sensor 504 embedded into the tip section 420. Various types of sensors 504 may be integrated into the guidewire 500.

Fig. 6 shows a further embodiment of a guidewire 600 according to an embodiment of the invention. In this embodiment the composite shaft 406 only has a single matrix material type. Also in this embodiment a cable 602 is attached to an exterior surface of the composite shaft 406. The cable 602 runs the length of the composite shaft 602 to the tip section 420 where it is connected to a sensor 604. In this embodiment the tip section 420 and the coating 422 are made of the same material. In another variation of this embodiment the tip section 420 and the coating 422 are made of different materials as is illustrated in Fig. 5.

Fig. 7 shows a guidewire 700 according to a further embodiment of the invention. The embodiment in Fig. 7 is similar to that shown in Fig. 4. In this embodiment there is only a single composite material 406 making up the composite shaft. Within the composite shaft 406 there is a first fiber optic 702 and a second fiber optic 704. The at least two fiber cores are spaced apart from each other to prevent load coupling between the fiber cores. A frequency domain reflectometer may then transmit light to and from the optical fibers. This may be then used for determining the position and/or shape sensing using Rayleigh scattering. A similar arrangement may also be used for constructing an optical fiber Bragg grating strain-sensor to detect deflection of the guidewire 700. In this embodiment the tip section 420 and the coating 422 are made of the same material. In another variation of this embodiment the tip section 420 and the coating 422 are made of different materials as is illustrated in Fig. 5.

Fig. 8 shows further embodiment of a guidewire 800 according to an embodiment of the invention. In this embodiment there is a resistive wire 802 attached to an outer surface of the composite shaft 406. On a surface of the tip 806 there is an electrode 804. The resistive wire 802 is connected to the electrode 804. The guidewire 800 may then be used as an electrophysiological potential sensor for example for an ECG machine. In this embodiment the tip section 420 and the coating 422 are made of the same material. In another variation of this embodiment the tip section 420 and the coating 422 are made of different materials as is illustrated in Fig. 5.

Fig. 9 shows a further embodiment of a guidewire 900 according to an embodiment of the invention. In this example there is a single fiber optic 902 embedded within the composite shaft 406. At the tip region 420 there is an optical coupling 904 connected to the fiber optic 902. The optical coupling 904 allows light 908 to be emitted into a region 906 surrounding the tip 420. The optical coupling 904 also allows light 910 to be

focused back into the fiber optic 902 to be analyzed. Such a guidewire 900 could for instance be used for an optical reflection spectrum sensor, an optical transmission spectrum sensor, or an optical fluorescence spectrum sensor. In this embodiment the tip section 420 and the coating 422 are made of the same material. In another variation of this embodiment the tip section 420 and the coating 422 are made of different materials as is illustrated in Fig. 5.

Fig. 10 shows a further embodiment of a guidewire 1000 according to the invention. The embodiment shown in Fig. 10 is similar to that in Fig. 9 except in this case there is a first fiber optic 1002 and a second fiber optic 1004. The first fiber optic 1002 is coupled to a first optical unit 1006 and the second fiber optic 1004 is connected to a second optical unit 1008. Optical unit 1006 focuses light that travels through the first fiber optic 1002 towards the tip region 420. Light is then emitted from the first optical unit 1006 into a region 1010 surrounding the tip 420. Light is then absorbed 1014 by optical unit 1008 which then focuses the light 1014 into fiber optic 1004 where it may be analyzed. Such a guidewire 1000 may be useful as an optical reflect spectrum sensor, an optical transmission spectrum sensor, and for an optical fluorescence spectrum sensor. In this embodiment the tip section 420 and the coating 422 are made of the same material. In another variation of this embodiment the tip section 420 and the coating 422 are made of different materials as is illustrated in Fig. 5.

Fig. 11 shows a flowchart which illustrates a method according to a further embodiment of the invention. First, in step 1100 a composite shaft which is formed from fibers and a cable is received. Next in step 1102 a sensor is connected to the cable.

Fig. 12 show a guidewire 1200 according to a further embodiment of the invention. The guidewire 1200 is similar to the embodiment shown in Fig. 5 except that the guidewire 1200 lacks a tapered region in its distal tip region. In this embodiment the tip section 420 and the coating 422 are made of the same material. In another variation of this embodiment the tip section 420 and the coating 422 are made of different materials as is illustrated in Fig. 5. The composite shaft in both the shaft region 402 and the distal tip region 404 are made of a composite with the same matrix material 406.

Fig. 13 shows a guidewire 1200 according to a further embodiment of the invention. The guidewire 1300 is similar to the embodiment shown in Fig. 12 in that it also lacks a taper in its distal tip region 404. In this embodiment the tip section 420 and the coating 422 are made of the same material. In another variation of this embodiment the tip section 420 and the coating 422 are made of different materials as is illustrated in Fig. 5. The

composite shaft in the shaft region 402 has a first matrix material 406 and composite shaft in the distal tip region 404 has a second matrix material 408. The use of a second matrix material may allow the flexibility of the distal tip region to be controlled without the use of a taper. For instance the second matrix material may have a flexibility greater than that of the first matrix material.

While the invention has been illustrated and described in detail in the drawings and foregoing description, such illustration and description are to be considered illustrative or exemplary and not restrictive; the invention is not limited to the disclosed embodiments.

Other variations to the disclosed embodiments can be understood and effected by those skilled in the art in practicing the claimed invention, from a study of the drawings, the disclosure, and the appended claims. In the claims, the word "comprising" does not exclude other elements or steps, and the indefinite article "a" or "an" does not exclude a plurality. A single processor or other unit may fulfill the functions of several items recited in the claims. The mere fact that certain measures are recited in mutually different dependent claims does not indicate that a combination of these measures cannot be used to advantage. A computer program may be stored/distributed on a suitable medium, such as an optical storage medium or a solid-state medium supplied together with or as part of other hardware, but may also be distributed in other forms, such as via the Internet or other wired or wireless telecommunication systems. Any reference signs in the claims should not be construed as limiting the scope.

LIST OF REFERENCE NUMERALS

	400	guide wire
	402	shaft region
	403	length extension
5	404	distal tip region
	406	composite with first matrix material
	408	composite with second matrix material
	410	taper
	412	length
10	414	length of taper
	416	outer diameter
	418	inner diameter
	420	tip section
	422	coating
15	500	guide wire
	502	cable
	504	sensor
	600	guide wire
	602	cable
20	604	sensor
	700	guide wire
	702	fiber optic
	704	fiber optic
	800	guide wire
25	802	resistive wire
	804	electrode
	806	surface of tip
	900	guide wire
	902	fiber optic
30	904	optics
	906	region surrounding tip
	908	emitted light
	910	received light

	1000	guide wire
	1002	fiber optic
	1004	fiber optic
	1006	optics
5	1008	optics
	1010	region surrounding tip
	1012	emitted light
	1014	received light
	1200	guide wire
10	1300	guide wire

CLAIMS:

1. A guide wire (400, 500, 600, 700, 800, 900, 1000, 1200, 1300), wherein the guide wire has a shaft region (402) and a distal tip region (404), wherein the shaft region comprises a composite shaft (406) comprising fibers aligned with a length extension (403) of the shaft region, wherein the fibers extend at least partially into the distal tip region, wherein
5 the distal tip region comprises a sensor (504, 604, 702, 704, 804, 904, 1006, 1008), wherein the shaft comprises a cable (502, 602, 702, 704, 802, 902, 1002, 1004), and wherein the cable is connected to the sensor.
2. The guide wire of claim 1, wherein the cable (502, 702, 704, 902, 1002, 1004)
10 is within the composite shaft.
3. The guide wire of claim 2, wherein the cable is a fiber optic cable (502, 702, 704, 902, 1002, 1004).
- 15 4. The guide wire of claim 3, wherein the sensor comprises: a thermometer (504), an accelerometer (504), a pressure sensor (504), an optical reflection spectrum sensor (902, 1002, 1004), an optical transmission spectrum sensor (902, 904, 1002, 1004), and/or an optical fluorescence spectrum sensor (902, 904, 1002, 1004, 1006, 1008).
- 20 5. The guide wire of claim 3, wherein the fiber optic cable comprises two or more single core optical fibers (702, 704), wherein the fiber optic cable is the sensor, and wherein the fiber optic cable is a fiber optic position and/or shape sensor.
6. The guide wire of claim 1, wherein the cable (602, 802) is attached to the
25 composite shaft.
7. The guide wire of any one of the preceding claims, wherein the cable is a resistive wire (502, 602, 802).

8. The guide wire of claim 7, wherein the sensor comprises: a temperature sensor (504, 604), a pressure sensor (504, 604), and/or an electrophysiological potential sensor (804).

5 9. The guide wire of any one of the preceding claims, wherein the composite shaft further comprises a first matrix material (406) for binding the fibers together, wherein the fibers in the distal tip region are connected with a second matrix material (408) for binding the fibers, and wherein the flexibility of the second matrix material is higher than the first matrix material.

10

10. The guidewire of any one of the preceding claims, wherein the fibers form a taper (410) within the distal tip region.

11. A catheter system comprising:

15 a guide wire (400, 500, 600, 700, 800, 900, 1000, 1200, 1300) according to any one of the preceding claims; and

a catheter, wherein the guide wire is configured for guiding the catheter.

12. A method of manufacturing a guidewire (400, 500, 600, 700, 800, 900, 1000, 1200, 1300), wherein the method comprises the steps of:

20

receiving (100, 200, 302) a composite shaft (406) comprising fibers aligned with a length extension of the composite shaft, wherein the composite shaft comprises a cable (502, 602, 702, 704, 802, 902, 1002, 1004); and

connecting (104, 206, 308) a sensor to the cable.

25

13. The method of claim 12, wherein the method further comprises forming (300) the composite shaft with a pultrusion process, wherein the cable is incorporated into the composite shaft during the pultrusion process.

30

14. The method of claim 12 or 13, wherein the composite shaft further comprises a first matrix material (406) for binding the fibers together, wherein the method further comprises the step of removing the first matrix material at the distal tip region.

15. The method of claim 12, 13, or 15, wherein the method further comprises the step of shaping (102, 204, 306) a distal tip region of the composite shaft into a taper (410).

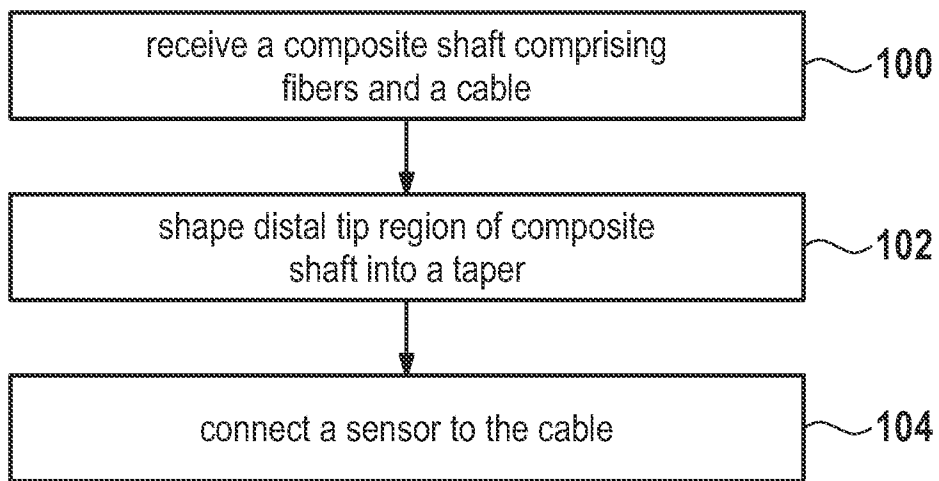
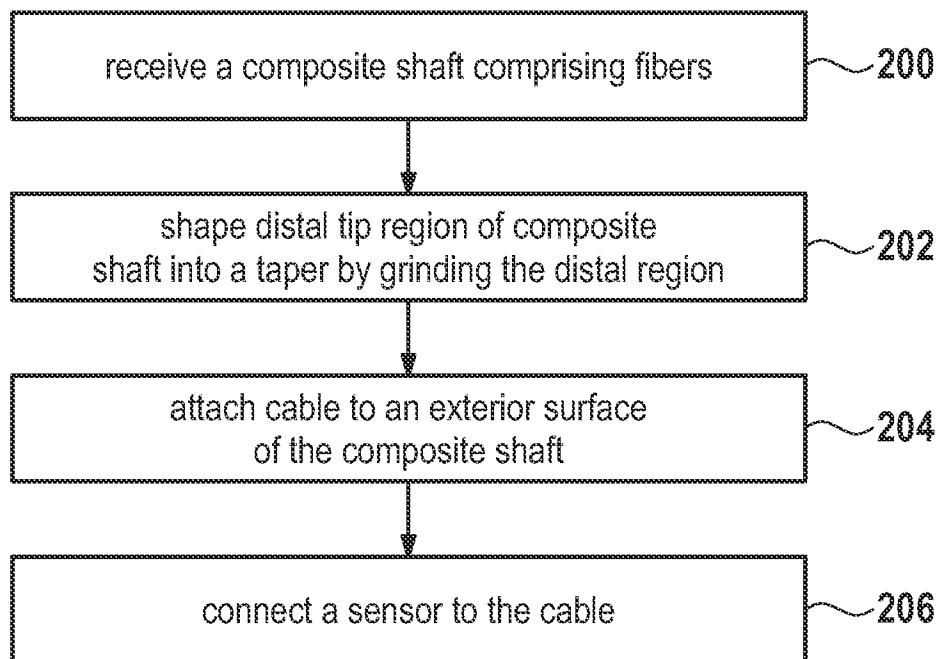

FIG. 1

2/9

**FIG. 2**

3/9

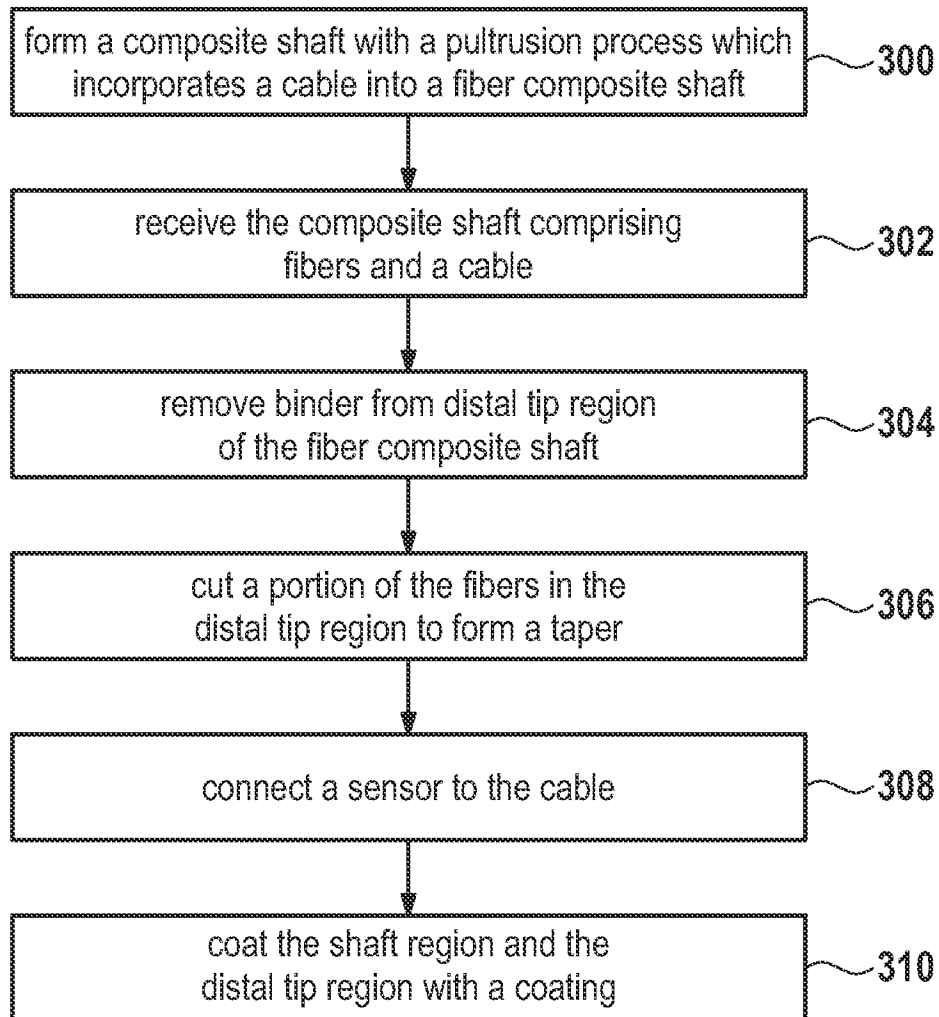

FIG. 3

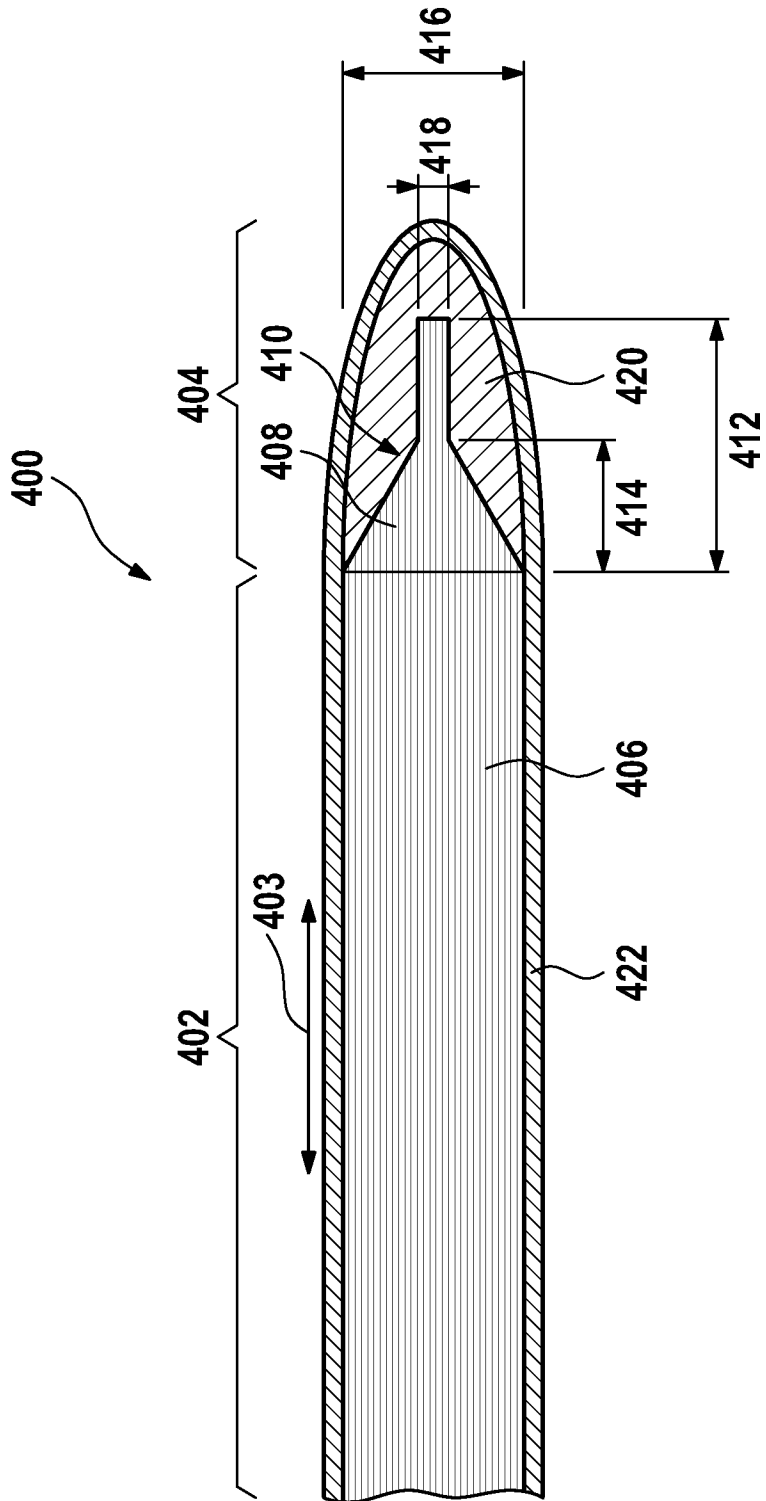

FIG. 4

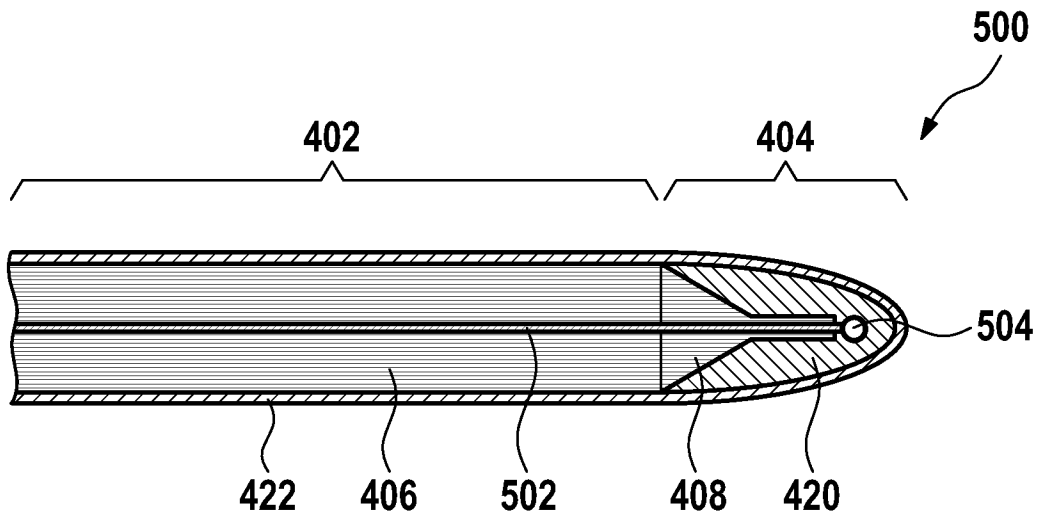

FIG. 5

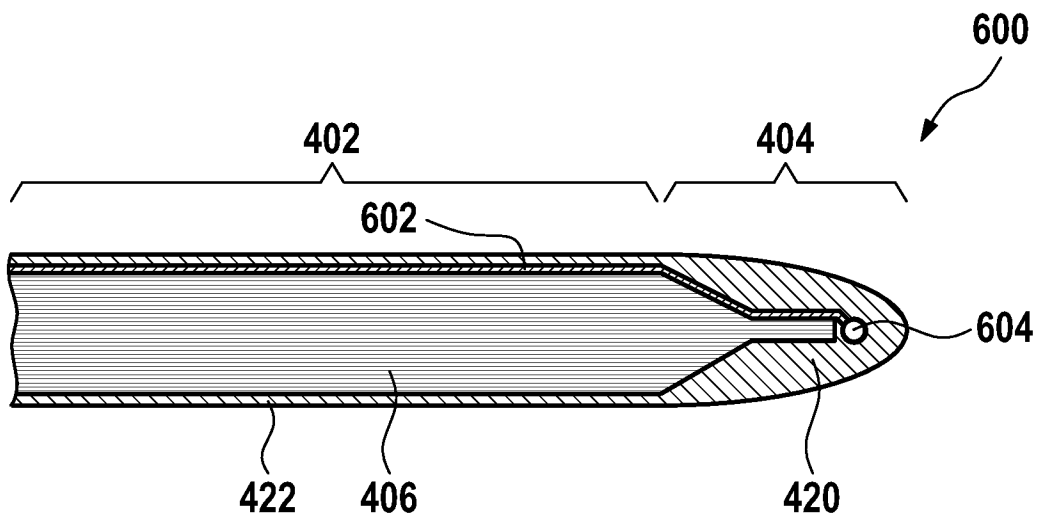

FIG. 6

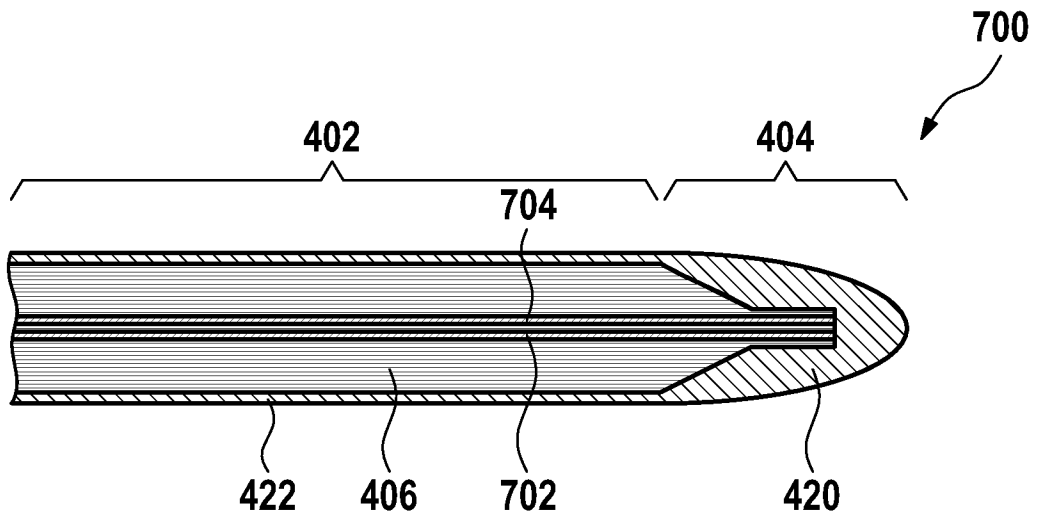

FIG. 7

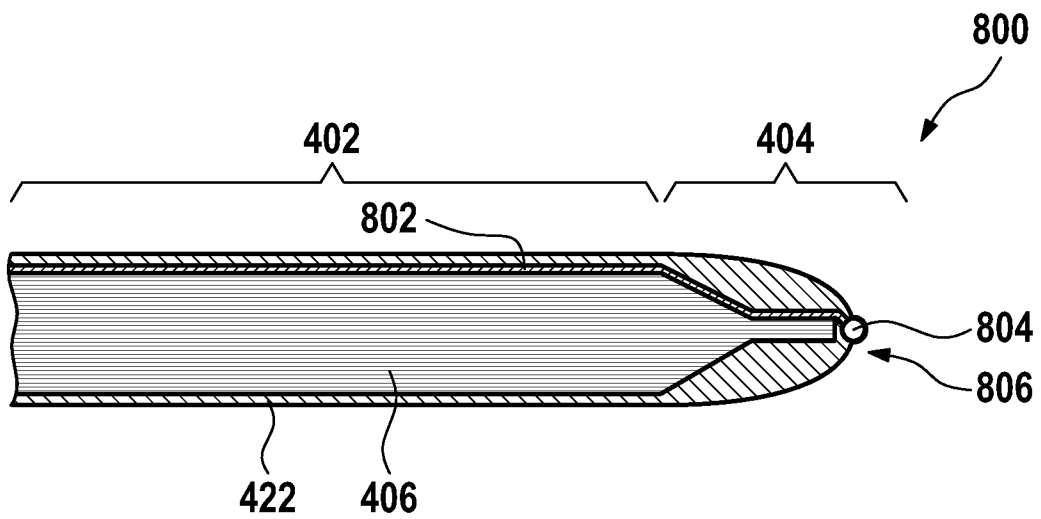

FIG. 8

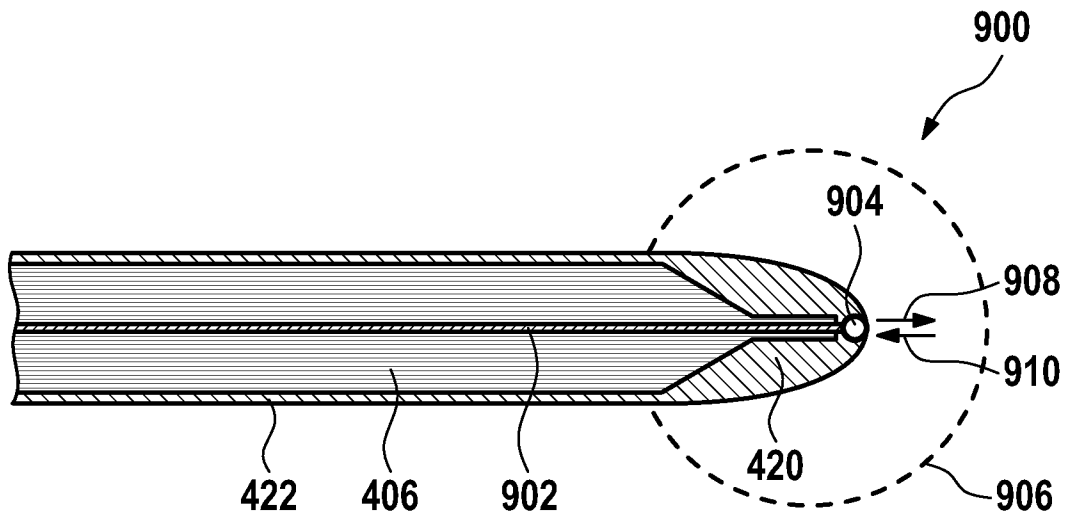

FIG. 9

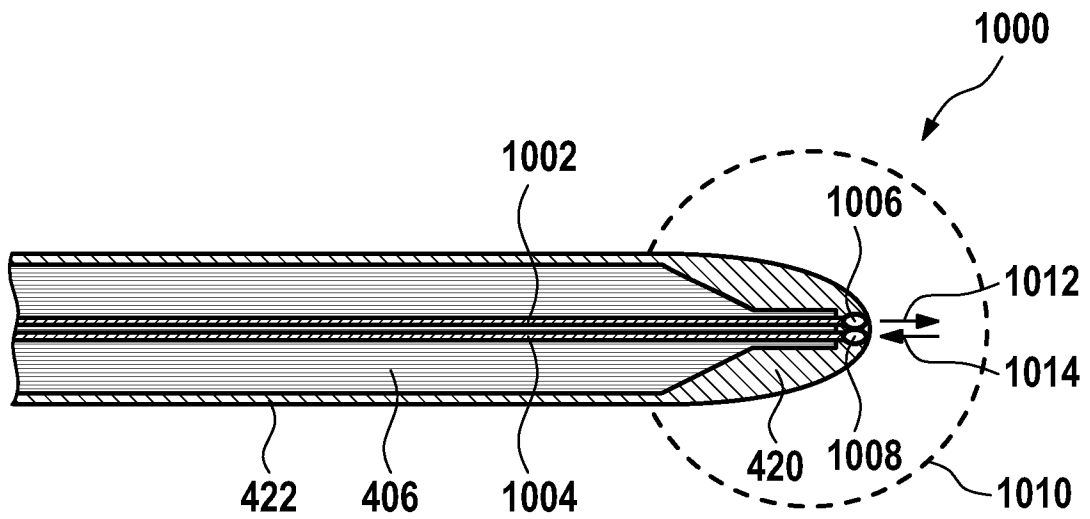

FIG. 10

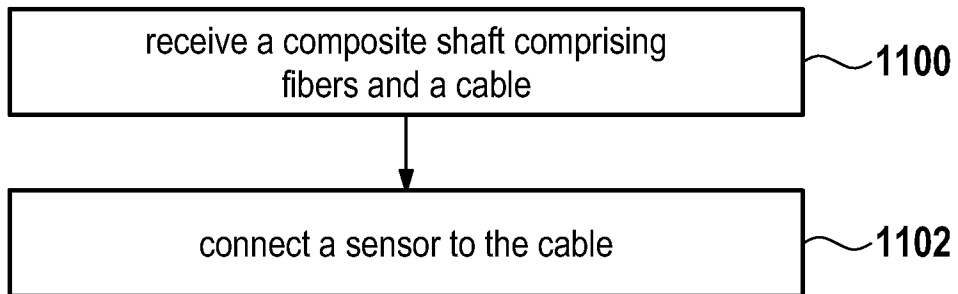

FIG. 11

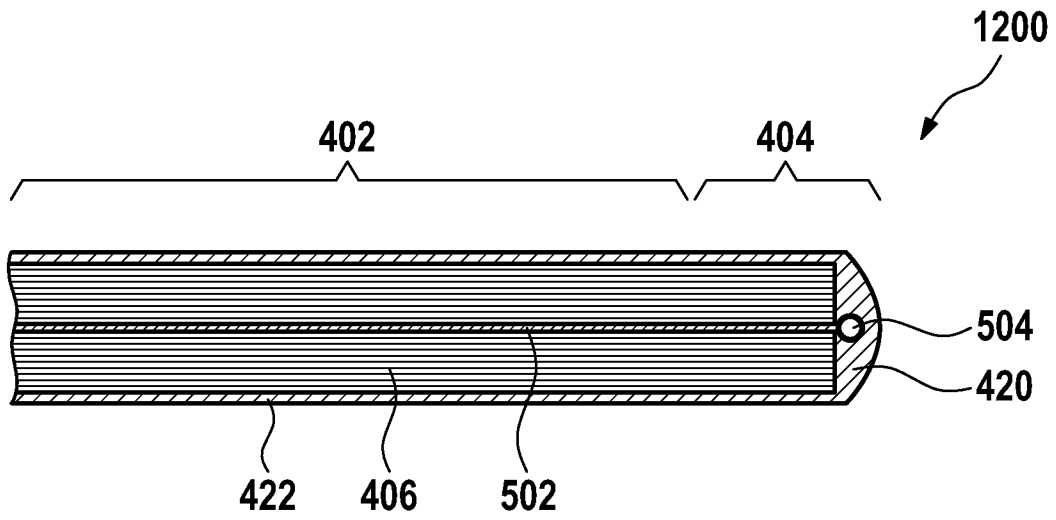

FIG. 12

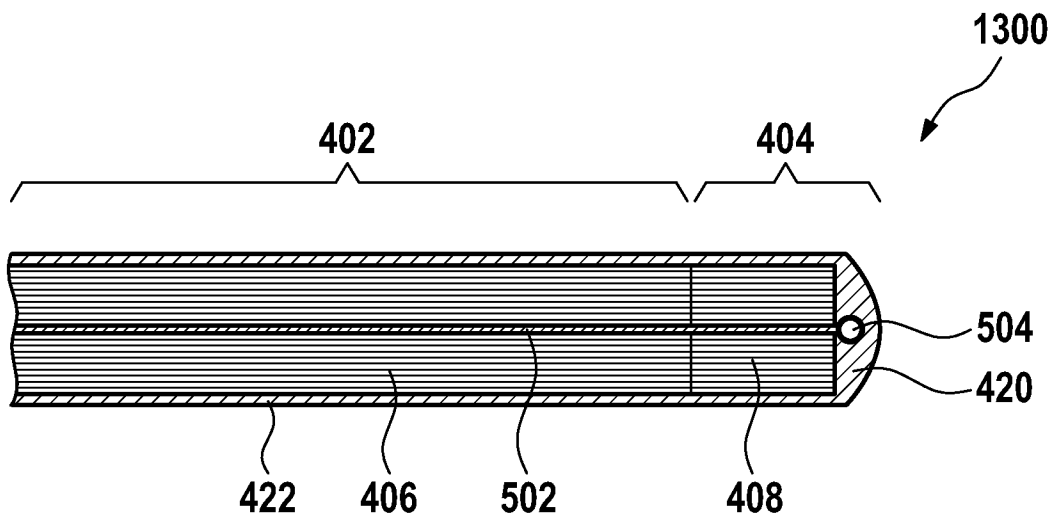

FIG. 13

INTERNATIONAL SEARCH REPORT

International application No
PCT/IB2012/052933

A. CLASSIFICATION OF SUBJECT MATTER
INV. A61M25/09 A61L31/12 B29C70/52
ADD.

According to International Patent Classification (IPC) or to both national classification and IPC

B. FIELDS SEARCHED

Minimum documentation searched (classification system followed by classification symbols)
A61M A61B

Documentation searched other than minimum documentation to the extent that such documents are included in the fields searched

Electronic data base consulted during the international search (name of data base and, where practicable, search terms used)

EPO-Internal, WPI Data

C. DOCUMENTS CONSIDERED TO BE RELEVANT

Category*	Citation of document, with indication, where appropriate, of the relevant passages	Relevant to claim No.
X	US 2008/312597 A1 (UIHLEIN BERNHARD [DE]) 18 December 2008 (2008-12-18) figure 11 figures 13, 16 paragraph [0002] paragraph [0011] paragraph [0012] paragraph [0014] paragraph [0055] paragraph [0062] paragraph [0064] paragraph [0066]	1-15
A	WO 2006/050385 A2 (PROTEUS BIOMEDICAL INC [US]; JENSON MARC [US]; THOMPSON TODD [US]; COL) 11 May 2006 (2006-05-11) paragraph [0141] paragraph [0148]	1-15

Further documents are listed in the continuation of Box C. See patent family annex.

* Special categories of cited documents :

"A" document defining the general state of the art which is not considered to be of particular relevance

"E" earlier application or patent but published on or after the international filing date

"L" document which may throw doubts on priority claim(s) or which is cited to establish the publication date of another citation or other special reason (as specified)

"O" document referring to an oral disclosure, use, exhibition or other means

"P" document published prior to the international filing date but later than the priority date claimed

"T" later document published after the international filing date or priority date and not in conflict with the application but cited to understand the principle or theory underlying the invention

"X" document of particular relevance; the claimed invention cannot be considered novel or cannot be considered to involve an inventive step when the document is taken alone

"Y" document of particular relevance; the claimed invention cannot be considered to involve an inventive step when the document is combined with one or more other such documents, such combination being obvious to a person skilled in the art

"&" document member of the same patent family

Date of the actual completion of the international search	Date of mailing of the international search report
6 September 2012	13/09/2012

Name and mailing address of the ISA/ European Patent Office, P.B. 5818 Patentlaan 2 NL - 2280 HV Rijswijk Tel. (+31-70) 340-2040, Fax: (+31-70) 340-3016	Authorized officer Przykutta, Andreas
--	--

INTERNATIONAL SEARCH REPORT

International application No
PCT/IB2012/052933

C(Continuation). DOCUMENTS CONSIDERED TO BE RELEVANT		
Category*	Citation of document, with indication, where appropriate, of the relevant passages	Relevant to claim No.
A	US 2010/228112 A1 (VON MALMBORG PAER [SE]) 9 September 2010 (2010-09-09) the whole document -----	1-15
A	US 2002/058888 A1 (BIAGTAN EMMANUEL C [US] ET AL) 16 May 2002 (2002-05-16) the whole document -----	1-15
A	US 5 251 640 A (OSBORNE THOMAS A [US]) 12 October 1993 (1993-10-12) the whole document -----	1-15

INTERNATIONAL SEARCH REPORT

Information on patent family members

International application No PCT/IB2012/052933

Patent document cited in search report	Publication date	Patent family member(s)	Publication date
US 2008312597 A1	18-12-2008	DE 102005022688 A1 US 2008312597 A1 WO 2006119989 A1	16-11-2006 18-12-2008 16-11-2006

WO 2006050385 A2	11-05-2006	US 2008255629 A1 WO 2006050385 A2	16-10-2008 11-05-2006

US 2010228112 A1	09-09-2010	EP 2211701 A1 US 2010228112 A1 WO 2009054802 A1	04-08-2010 09-09-2010 30-04-2009

US 2002058888 A1	16-05-2002	AU 2907202 A EP 1341575 A2 JP 2004515323 A US 2002058888 A1 WO 0247755 A2	24-06-2002 10-09-2003 27-05-2004 16-05-2002 20-06-2002

US 5251640 A	12-10-1993	NONE	
