



(86) Date de dépôt PCT/PCT Filing Date: 2009/07/24
 (87) Date publication PCT/PCT Publication Date: 2010/01/28
 (85) Entrée phase nationale/National Entry: 2011/01/24
 (86) N° demande PCT/PCT Application No.: IB 2009/053564
 (87) N° publication PCT/PCT Publication No.: 2010/010544
 (30) Priorité/Priority: 2008/07/24 (EE P200800049)

(51) Cl.Int./Int.Cl. *F03D 11/00* (2006.01),
F03D 11/02 (2006.01)
 (71) Demandeurs/Applicants:
SONAJALG, ANDRES, EE;
SONAJALG, OLEG, EE
 (72) Inventeurs/Inventors:
SONAJALG, ANDRES, EE;
SONAJALG, OLEG, EE
 (74) Agent: BROUILLETTE & ASSOCIES/PARTNERS

(54) Titre : GENERATEUR D'ENERGIE EOLIENNE
 (54) Title: WIND TURBINE

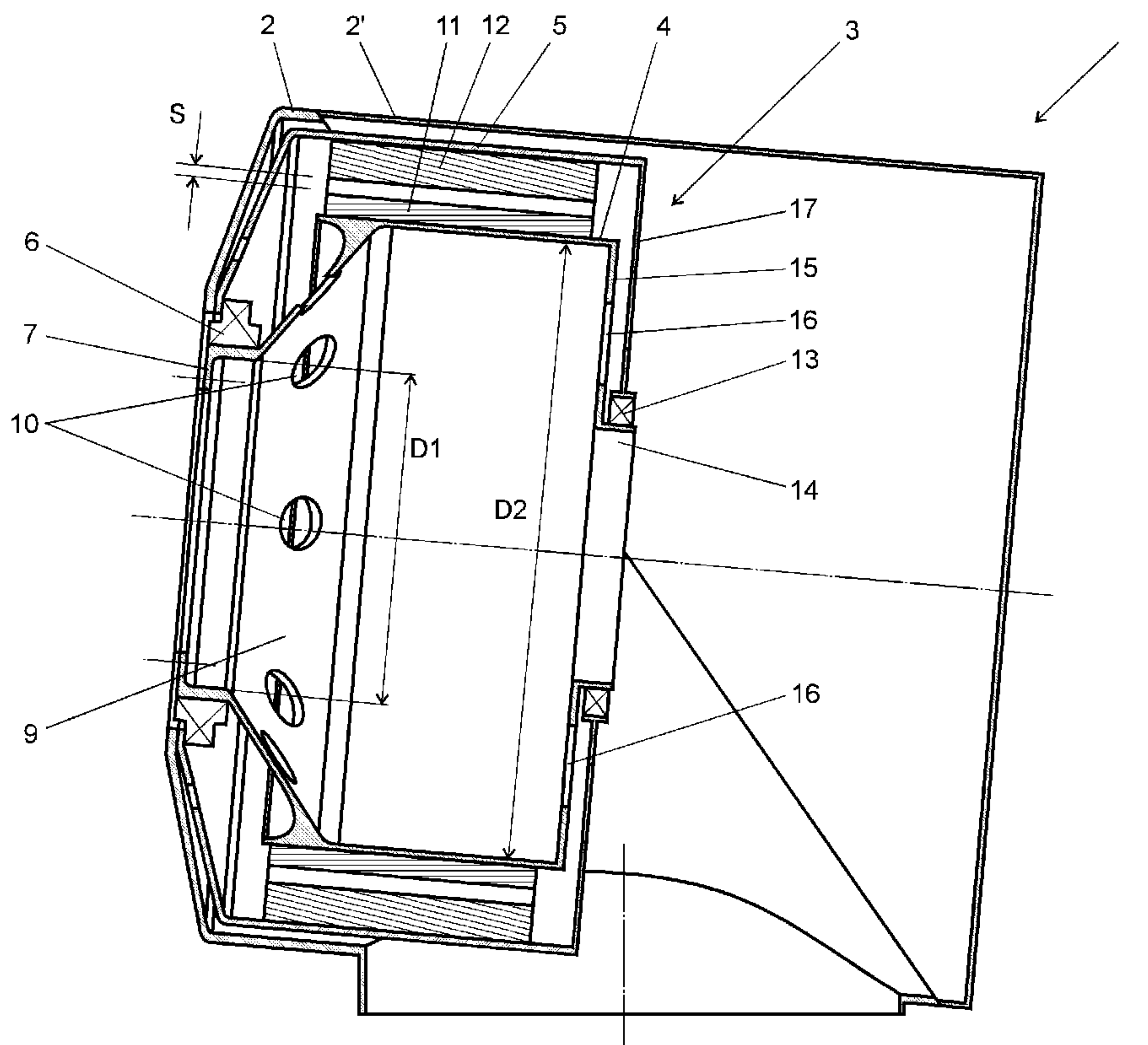

FIG 1

(57) Abrégé/Abstract:

This invention relates to an improved construction of wind turbine, the aim of which is to enhance the stability of the wind turbine and improve the balance between the generator and the tower, as well as to separate the generator from the function of the bearing structural part, enabling to direct the force generated in the turbine to the generator details.

Abstract

This invention relates to an improved construction of wind turbine, the aim of which is to enhance the stability of the wind turbine and improve the balance between the generator and the tower, as well as to separate the generator from the function
5 of the bearing structural part, enabling to direct the force generated in the turbine to the generator details.

Wind turbine

TECHNICAL FIELD

The present invention relates, in general, to equipment for producing and storing wind power, and in particular, to an improved construction of wind turbine.

5 DESCRIPTION OF RELATED ART

There are several types of wind turbines, which comprise a base, a tower and a wind turbine fixed to the tower. The earlier wind turbine construction included a turbine connected to blades, a main shaft, a reducer and a generator part with a stator and a rotor. The kinds of generators present the problem of exhaustion
10 caused by the transmission of main shaft-reducer-generator. Furthermore, such structure cannot be used for wind turbines that exceed the capacity of 1,500 kW as the torque generated by the main shaft and reducer becomes too excessive, and the construction suffers from exhaustion and material fatigue, which may result in damage to the structure.

15 Another known solution of wind turbines is a reducer-free wind turbine produced by a company called Enercon using the inventions of Wobben Aloys, where the tower is connected to a knee-shaped console, which is in turn connected to a main shaft connected to an impeller head that is fixed to a generator part. One such solution has been described in a patent application number EP1794450, filed on
20 June 13th, 2007, where a console with a main shaft, nacelle and rotor, is connected to a tower. The weakness of such a solution lies in the connections of the console and the tower as the wind power acts upon the turbine (blade length 35-40m) is transferred to the connections of the console, which are thus subject to material fatigue and may break. Furthermore, these kinds of wind turbines are also
25 problematic due to insufficient cooling; the air-tightness of the windings in the generator structure should be ensured at the same time. Different solutions have been proposed, but so far the cooling and structural reliability remain problematic. Also, the proposed solutions are expensive and material consuming.

The closest solution of a wind power generator is that described in the patent application No. P200700038 filed by the present authors, the development of which is the present invention. Therefore, the following description includes references to the details presented in the previous application.

5 SUMMARY OF INVENTION

The aim of the present invention is to propose such a wind turbine structure, which would enable to:

- improve the balance between the part installed on the wind turbine and the tower;
- 10 - separate the generator from the function of the bearing structure, enabling not to direct the forces coming from the turbine to generator details (except for the torque);
- cool the knots and components in the body of the wind turbine effectively;
- to ensure the required air-tightness considering that the wind turbines are mostly
- 15 positioned in the sea, ocean and on the coast, where in addition to the humidity the wind also carries the particles of mineral salts from the sea water, which in turn cause the premature corrosion of the details, considerable deterioration of the insulation of the generator and electric puncture in the windings.

For that purpose the authors of the invention suggest such a wind turbine structure

20 where the main shaft of the wind turbine is concurrently generator rotor body is a hollow, tubular structure, which is connected from one end to the impeller head with blades. The wind turbine rotor body is supported in the generator body, which is formed of a tube with the help of a bearing or bearings, which have been installed at the centre of the outer surface of the main shaft onto the first part. The

25 bearings can comprise both ball bearings and roller bearings (also inclined roller bearings), for the state-of-the-art technologies enable to make bearing rollers and bearings with any size. At the same time, such structure ensures the air-tightness between wind turbine rotor body and the main frame, simultaneously, the air flows through the wind turbine rotor body, with the help of which necessary knots and

30 components are cooled.

BRIEF DESCRIPTION OF THE DRAWINGS

In the following, the invention is described in more detail in reference to the attached drawings, where

Figure 1 shows the cross-section of the wind turbine according to the present invention,

Figure 2 shows the perspective rear view of the generator part and the wind turbine rotor body, whereas the upper part of the body has been removed,

Figure 3 shows the perspective view of the generator part of the wind turbine according to the invention.

10 DETAILED DESCRIPTION OF THE INVENTION

The wind turbine 1 depicted in the drawings is via the connections known in the field of the art to the top of the bearing tower, etc. of the wind turbine . Wind turbine 1 comprises main frame 2, 2', which surrounds the generator part 3, or working chamber, an impeller head (not shown in the drawings), which holds the blades of the generator and a connection part (not shown) by which the wind turbine 1 is fixed to the tower, which lies on the ground on a special base (not shown). The interior of the tower has the knots and components arranged and installed, which are necessary for the operation of the wind turbine 1.

Generator part 3 is formed of the wind turbine rotor body 4 and of a stator body 5.

20 The impeller head is connected to the wind turbine rotor body 4 of the generator part 3 using a connection method known in the field of construction of wind turbines, wherefore this is not explained further hereunder. Furthermore, the impeller blades are fixed to the impeller head applying the solutions known in the state of the art.

25 The wind turbine rotor body 4 of the wind power generator has been divided into two parts 2, 2' so that the lower part 2 of the main body is joined to the tower and the upper part 2' of the main body is connected to the lower part 2 of the main body at the final stage of the assembly of the wind power generator 1. The use of

such a construction for the main body enables to lift the components and knots of the wind power generator in place and assemble them in a quick and easy manner.

5 The wind turbine rotor body 4 is a hollow cylindrical detail with open ends, which at the end of the impeller head is supported in the main frame 2 via a bearing 6. The bearing could be a double-row conical roller bearing produced by company SKF, which is, first and foremost, meant to operate under heavy loads, and in conditions where composite loads act upon the structure. Furthermore, another type of bearing is used, which is compatible with the conditions arising from the bearing
10 and impacting load.

The internal ring of the bearing 6 surrounds the wind turbine rotor body 4, or the bearing has been fixed to the exterior surface of the wind turbine rotor body 4 with tensioning or to the flanges on the exterior of the wind turbine rotor body 4 with bolts (not shown), in order to ensure the fixed connection between the internal ring
15 of the bearing 6 and the exterior surface of the wind turbine rotor body 4. At the side of the impeller head of the wind turbine rotor body 4 is a flange 7 running towards the inside of the axle of the wind turbine rotor body 4, which has drilled openings for securing devices and which shall hold the impeller head installed in the course of assembly of the wind turbine.

20 The main frame 2 of the wind turbine has a stator body 5 secured to it, which body surrounds the wind turbine rotor body 4, and which is also connected to the stator windings 12 and the outer ring of the bearing 6. In this way an immobile connection of the outer ring of the bearing 6 and stator body 5 to the main frame 2 is secured.

25 The wind turbine rotor body 4 depicted in the drawings also includes a conical part 9, which enables to increase the inner diameter $D1$ to $D2$ ($D2 > D1$) of the wind turbine rotor body 4. The conical part 9 also has openings 10, through which the air used for cooling can move into stator body 5. Rotor windings or magnets 11 are fixed on to the outer surface of the wind turbine rotor body 4 on the side of stator
30 body 5. On the inner surface of the stator body 5 stator windings 12 are fixed, the width of which corresponds to the width of the rotor windings 11. At the same time,

both rotor windings and stator windings could be divided into segments, etc. in a way to facilitate the maintenance and repairs of the wind turbine.

In order to ensure the air gaps between the stator 12 and rotor 11 required for their proper operation, the stator body 5 and the wind turbine rotor body 4 are mutually supported via support bearing 13. Support bearing 13 has been fixed with the inner bearing ring to the support part 14 on the end of the wind turbine rotor body 4. The support part 14 itself is fixed to the end plate 15 located at the rear part of the wind turbine rotor body 4, which is at a distance from the impeller head, being connected to the wind turbine rotor body . The end plate 15 incorporates the openings 16 for cooling air. The support part 14 is located at the centre of the end plate 15 in the axle direction of the wind turbine rotor body 4 and is a cylindrical detail, the outer surface of which holds a connection with the inner ring of the support bearing 13.

The outer ring of the bearing 13 is fixed to stator body 5 via end plate 17 at the end of the stator body 5. The end plates 15, 17 of both the wind turbine rotor body 4 and the stator body 5 may be made as spokes in order to ensure the freer passage for cooling air from the generator part.

The main task of the support bearing 13 is to ensure a permanent gap s between the rotor 11 and the stator 12, which is in turn necessary for the operation of the wind turbine 1.

The advantage of the wind turbine described above is the fact that the centre of gravity of the entire wind turbine 1, mostly that of the rotor 11 and stator 12 could be brought closer to the central axle of the tower, which in turn reduces the load acting on the console structure of the main frame 2, 2'.

The frame of the wind turbine 2, 2' may be fixed to the tower with flange connections, which are not described in further detail hereunder as they are not related to the technical solution presented in the invention.

The specialists of the field understand that the wind power generator construction according to the invention is not limited to the embodiment described above. For example, the length of the wind turbine rotor body could be modified so that the

dimension of the entire wind turbine from blades to the rear end of the generator part has taken to a minimum and/or using only one bearing – in such a way the construction is made lighter and its installation and operation easier.

Wind Power Generator

TECHNICAL FIELD

The present invention relates, in general, to equipment for producing and storing wind power, and in particular, to an improved construction of wind power generator.

DESCRIPTION OF RELATED ART

There are several types of wind power generators, which comprise a base, a tower and a wind power generator fixed to the tower. The earlier wind power generator construction included a turbine connected to blades, a main shaft, a reducer and a generator part with a stator and a rotor. The kinds of generators present the problem of exhaustion caused by the transmission of main shaft-reducer-generator. Furthermore, such structure cannot be used for wind power generators that exceed the capacity of 1,500 kW as the torque generated by the main shaft and reducer becomes too excessive, and the construction suffers from exhaustion and material fatigue, which may result in damage to the structure.

Another known solution of wind power generators is a reducer-free wind power generator produced by a company called Enercon using the inventions of Wobben Aloys, where the tower is connected to a knee-shaped console, which is in turn connected to a main shaft connected to an impeller head that is fixed to a generator part. One such solution has been described in a patent application number EP1794450, filed on June 13th, 2007, where a console with a main shaft, nacelle and rotor, is connected to a tower. The weakness of such a solution lies in the connections of the console and the tower as the wind power acts upon the turbine (blade length 35-40m) is transferred to the connections of the console, which are thus subject to material fatigue and may break. Furthermore, these kinds of wind power generators are also problematic due to insufficient cooling; the air-tightness of the windings in the generator structure should be ensured at the same time. Different solutions have been proposed, but so far the cooling and

structural reliability remain problematic. Also, the proposed solutions are expensive and material consuming.

The closest solution of a wind power generator is that described in the patent application No. P200700038 filed by the present authors, the development of which is the present invention. Therefore, the following description includes references to the details presented in the previous application.

SUMMARY OF INVENTION

The aim of the present invention is to propose such a wind power generator structure, which would enable to:

- 10 - improve the balance between the part installed on the wind power generator and the tower;
- separate the generator from the function of the bearing structure, enabling not to direct the forces coming from the turbine to generator details (except for the torque);
- 15 - cool the knots and components in the body of the wind power generator effectively;
- to ensure the required air-tightness considering that the wind power generators are mostly positioned in the sea, ocean and on the coast, where in addition to the humidity the wind also carries the particles of mineral salts from the sea water,
- 20 which in turn cause the premature corrosion of the details, considerable deterioration of the insulation of the generator and electric puncture in the windings.

For that purpose the authors of the invention suggest such a wind power generator structure where the main shaft of the wind power generator is hollow, i.e. the shaft has a tubular structure. At one end of the tube an impeller head with blades is fixed, and the other end contains a generator with a rotor and stator. The main shaft is supported in the generator body, which is formed of a tube with the help of a bearing or bearings, which have been installed at the centre of the outer surface of the main shaft onto the first part. The bearings can comprise both ball bearings and roller bearings (also inclined roller bearings), for the state-of-the-art

technologies enable to make bearing rollers and bearings with any size. At the same time, such structure ensures the air-tightness between the main shaft and the body, simultaneously, the air flows through the main shaft, with the help of which necessary knots and components are cooled.

5 BRIEF DESCRIPTION OF THE DRAWINGS

In the following, the invention is described in more detail in reference to the attached drawings, where

Figure 1 shows the cross-section of the wind power generator according to the present invention,

10 Figure 2 shows the perspective rear view of the generator part and the main shaft, whereas the upper part of the body has been removed,

Figure 3 shows the perspective view of the generator part of the wind power generator according to the invention.

DETAILED DESCRIPTION OF THE INVENTION

15 The wind power generator 1 depicted in the drawings is via the connections known in the field of the art to the top of the bearing tower, etc. of the wind power generator. Wind power generator 1 comprises two-part main body 2, 2', which surrounds the generator part 3, or working chamber, an impeller head (not shown in the drawings), which holds the blades of the generator and a connection part
20 (not shown) by which the wind power generator 1 is fixed to the tower, which lies on the ground on a special base (not shown). The interior of the tower has the knots and components arranged and installed, which are necessary for the operation of the wind power generator 1.

Generator part 3 is formed of the main shaft 4 and of a stator body 5.

25 The impeller head is connected to the main shaft 4 of the generator part 3 using a connection method known in the field of construction of wind power generators,

wherefore this is not explained further hereunder. Furthermore, the impeller blades are fixed to the impeller head applying the solutions known in the state of the art. The main body of the wind power generator has been divided into two parts 2, 2' so that the lower part 2 of the main body is joined to the tower and the upper part 2' of the main body is connected to the lower part 2 of the main body at the final stage of the assembly of the wind power generator 1. The use of such a construction for the main body enables to lift the components and knots of the wind power generator in place and assemble them in a quick and easy manner.

The main shaft 4 is a hollow cylindrical detail with open ends, which at the end of the impeller head is supported in the main body 2 via a bearing 6. The bearing could be a double-row conical roller bearing produced by company SKF, which is, first and foremost, meant to operate under heavy loads, and in conditions where composite loads act upon the structure. Furthermore, another type of bearing is used, which is compatible with the conditions arising from the bearing and impacting load.

The internal ring of the bearing 6 surrounds the main shaft 4, or the bearing has been fixed to the exterior surface of the main shaft 4 with tensioning or to the flanges on the exterior of the main shaft 4 with bolts (not shown), in order to ensure the fixed connection between the internal ring of the bearing 6 and the exterior surface of the main shaft 4. At the side of the impeller head of the main shaft 4 is a flange 7 running towards the inside of the axle of the main shaft 4, which has drilled openings for securing devices and which shall hold the impeller head installed in the course of assembly of the wind power generator.

The main body 2 of the wind power generator has a stator body 5 secured to it, which body surrounds the main shaft 4, and which is also connected to the stator windings 12 and the outer ring of the bearing 6. In this way an immobile connection of the outer ring of the bearing 6 and stator body 5 to the main body 2 is secured.

The main shaft 4 depicted in the drawings also includes a conical part 9, which enables to increase the inner diameter $D1$ to $D2$ ($D2 > D1$) of the main shaft 4. The

conical part 9 also has openings 10, through which the air used for cooling can move into stator body 5. Rotor windings or magnets 11 are fixed on to the outer surface of the main shaft 4 on the side of stator body 5. On the inner surface of the stator body 5 stator windings 12 are fixed, the width of which corresponds to the width of the rotor windings 11. At the same time, both rotor windings and stator windings could be divided into segments, etc. in a way to facilitate the maintenance and repairs of the wind power generator.

In order to ensure the air gap s between the stator 12 and rotor 11 required for their proper operation, the stator body 5 and the main shaft 4 are mutually supported via support bearing 13. Support bearing 13 has been fixed with the inner bearing ring to the support part 14 on the end of the main shaft 4. The support part 14 itself is fixed to the end plate 15 located at the rear part of the main shaft 4, which is at a distance from the impeller head, being connected to the main shaft. The end plate 15 incorporates the openings 16 for cooling air. The support part 14 is located at the centre of the end plate 15 in the axle direction of the main shaft 4 and is a cylindrical detail, the outer surface of which holds a connection with the inner ring of the support bearing 13.

The outer ring of the bearing 13 is fixed to stator body 5 via end plate 17 at the end of the stator body 5. The end plates 15, 17 of both the main shaft 4 and the stator body 5 may be made as spokes in order to ensure the freer passage for cooling air from the generator part.

The main task of the support bearing 13 is to ensure a permanent gap s between the rotor 11 and the stator 12, which is in turn necessary for the operation of the wind power generator 1.

The advantage of the wind power generator described above is the fact that the centre of gravity of the entire wind power generator 1, mostly that of the rotor 11 and stator 12 could be brought closer to the central axle of the tower, which in turn reduces the load acting on the console structure of the main body 2, 2'.

6

The body of the wind power generator 2 may be fixed to the tower with flange connections, which are not described in further detail hereunder as they are not related to the technical solution presented in the invention.

5 The specialists of the field understand that the wind power generator construction according to the invention is not limited to the embodiment described above. For example, the length of the main shaft could be modified so that the dimension of the entire wind power generator from blades to the rear end of the generator part has taken to a minimum and/or using only one bearing – in such a way the construction is made lighter and its installation and operation easier.

10

Claims

1. Wind power generator (1) comprising a tower, the main body of the generator (2, 2'), which surrounds the generator part (3), impeller head and the connection part, **characterised** in that the generator part (3) comprises a main shaft (4),
5 which is surrounded by stator body (5), whereas the main shaft (4) is a hollow cylindrical detail, and that the main shaft (4) is supported on the side of the impeller head via a bearing (6) on to the main body (2), so that the stator body (5) has been fixed to the outer ring of the bearing (6), which is fixed to the main body (2), whereas the stator body (5) has been fixed to the end of the propeller head of
10 the main body (2).

2. Wind power generator according to claim 1, **characterised** in that on the other end of the main shaft (4) further from the impeller head has an end plate (15), the centre of which has a cylindrical support part (14) directed to the axle of the main shaft (4) having the same axle, the outer surface of which incorporates the inner
15 ring of the support bearing (13), and that on the other end of the stator body (5) further from the impeller head has an end plate (17), the centre of which has an opening with a support flange the diameter of which corresponds to the outer diameter of the bearing (13), whereas the end plate (17) with the opening integrated is supported to the outer ring of the bearing (13) so that there is a
20 tensioning between the outer surface of the outer ring and the opening in the end plate.

3. Wind power generator according to claim 1 and 2, **characterised** in that the outer surface of the main shaft (4) incorporates essentially to the entire width of the main shaft (4) rotor windings or magnets (11) so that the inner surface of the
25 stator body (5) has stator windings (12) fixed to an extent that corresponding to the width of rotor windings (11), whereas between the windings of the stator and the rotor (12, 11) there is a fixed air gap S.

4. Wind power generator according claims 1, 2 and 3, **characterised** in that the main body (2, 2') of the wind power generator (1) is connected to the stator body

WO 2010/010544

PCT/IB2009/053564

8

(5) only at the impeller head end, and is thus separated by the air gap with the rest of the stator body (5).

5. Wind power generator according to claim 1, **characterised** in that the bearing (6) is a two-row conical roller bearing or a three-row roller bearing.

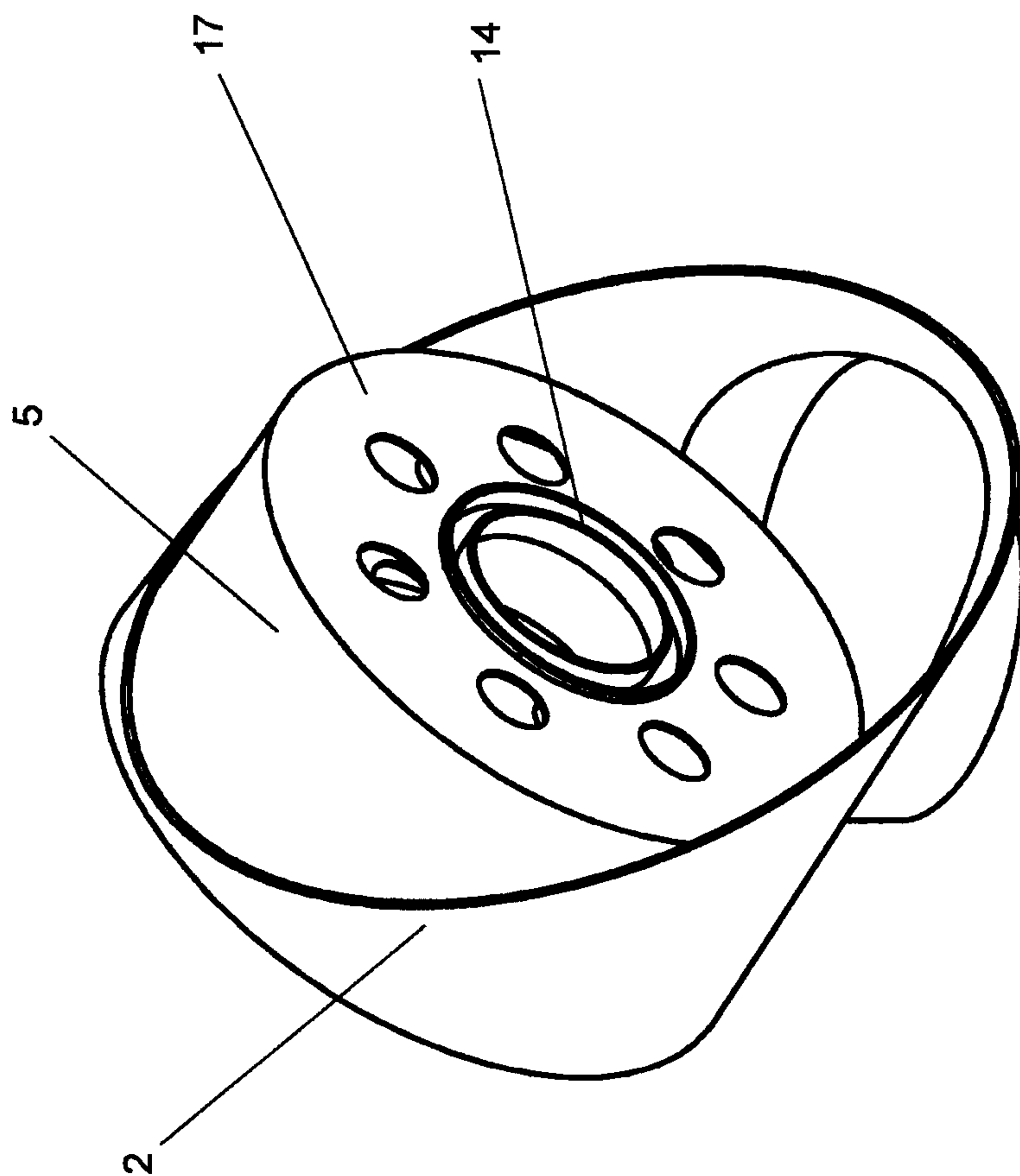

FIG 2

3/3

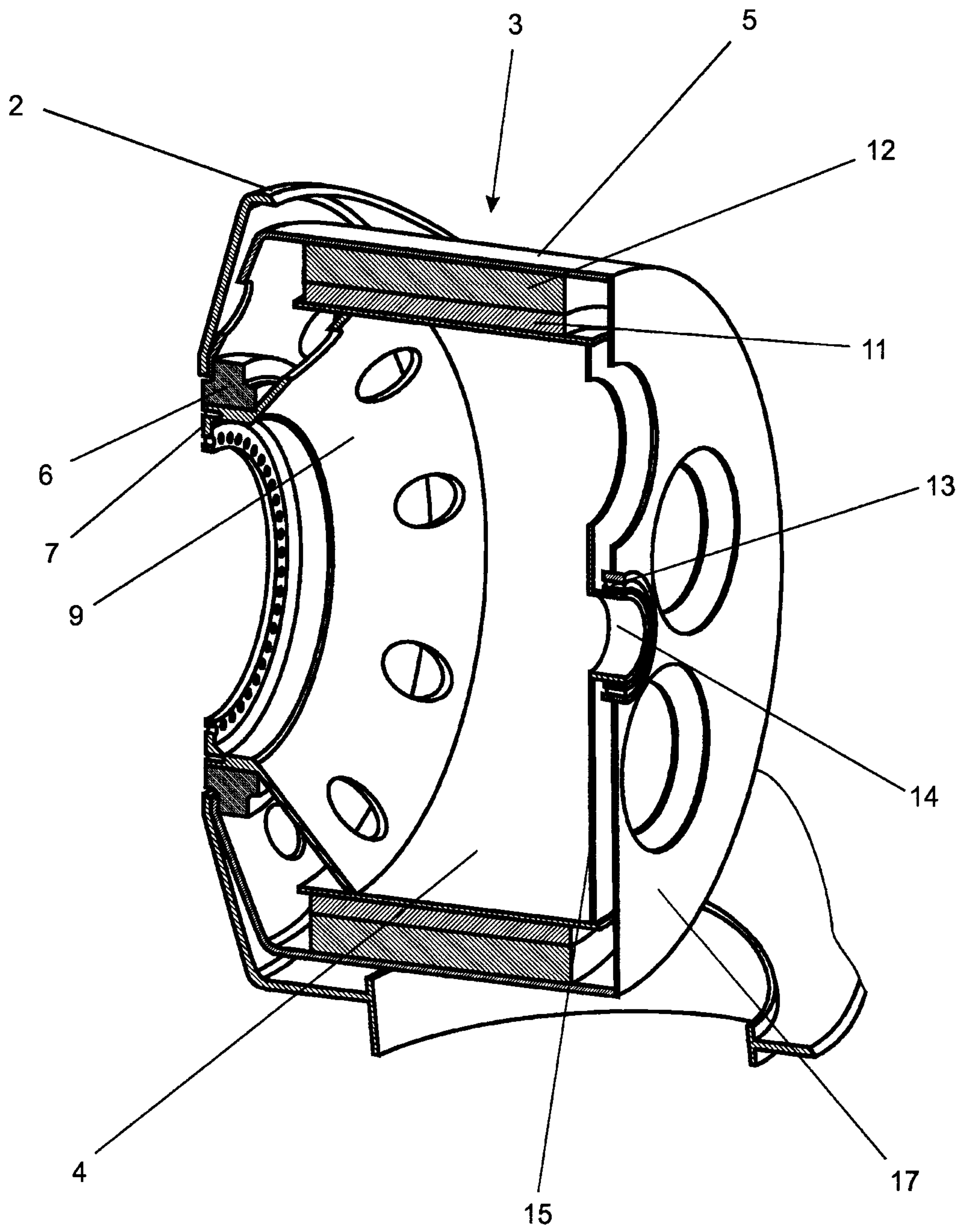

FIG 3

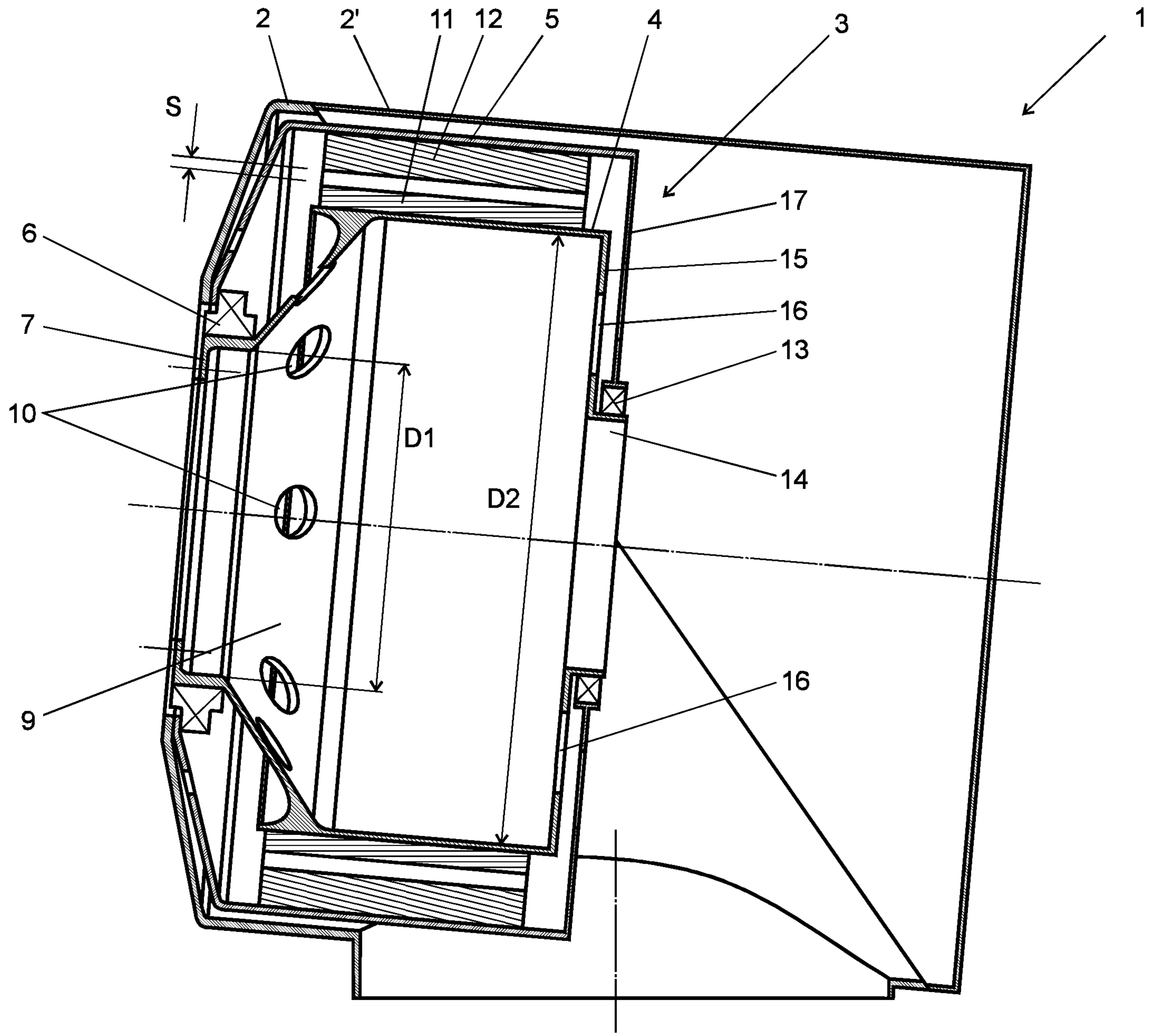

FIG 1