

(19) World Intellectual Property Organization
International Bureau



(43) International Publication Date
22 September 2011 (22.09.2011)

(10) International Publication Number
WO 2011/115548 A1

(51) International Patent Classification:
B65B 27/06 (2006.01) *B65B 25/24* (2006.01)
B65B 11/04 (2006.01)

(74) Agent: **BERGENSTRÄHLE & LINDVALL AB**;
P.O.Box 17704, Ringvägen 100, S-11893 Stockholm
(SE).

(21) International Application Number:
PCT/SE2011/050265

(81) Designated States (unless otherwise indicated, for every kind of national protection available): AE, AG, AL, AM, AO, AT, AU, AZ, BA, BB, BG, BH, BR, BW, BY, BZ, CA, CH, CL, CN, CO, CR, CU, CZ, DE, DK, DM, DO, DZ, EC, EE, EG, ES, FI, GB, GD, GE, GH, GM, GT, HN, HR, HU, ID, IL, IN, IS, JP, KE, KG, KM, KN, KP, KR, KZ, LA, LC, LK, LR, LS, LT, LU, LY, MA, MD, ME, MG, MK, MN, MW, MX, MY, MZ, NA, NG, NI, NO, NZ, OM, PE, PG, PH, PL, PT, RO, RS, RU, SC, SD, SE, SG, SK, SL, SM, ST, SV, SY, TH, TJ, TM, TN, TR, TT, TZ, UA, UG, US, UZ, VC, VN, ZA, ZM, ZW.

(22) International Filing Date:
10 March 2011 (10.03.2011)

(25) Filing Language: English

(26) Publication Language: English

(30) Priority Data:
1050231-8 15 March 2010 (15.03.2010) SE
61/315,095 18 March 2010 (18.03.2010) US

(71) Applicants (for all designated States except US): **LAMI-FLEX AB** [SE/SE]; Gasverksvägen 4-6, S-61135 Nyköping (SE). **KNA Corporation OY** [FI/FI]; Trikookuja 3, FI-61600 Jalasjärvi (FI).

(84) Designated States (unless otherwise indicated, for every kind of regional protection available): ARIPO (BW, GH, GM, KE, LR, LS, MW, MZ, NA, SD, SL, SZ, TZ, UG, ZM, ZW), Eurasian (AM, AZ, BY, KG, KZ, MD, RU, TJ, TM), European (AL, AT, BE, BG, CH, CY, CZ, DE, DK, EE, ES, FI, FR, GB, GR, HR, HU, IE, IS, IT, LT, LU, LV, MC, MK, MT, NL, NO, PL, PT, RO, RS, SE, SI, SK, SM, TR), OAPI (BF, BJ, CF, CG, CI, CM, GA, GN, GQ, GW, ML, MR, NE, SN, TD, TG).

(72) Inventors; and

(75) Inventors/Applicants (for US only): **OLSSON, Kristoffer** [SE/SE]; Oxelögatan 11B, S-61333 Oxelösund (SE). **PERASTO, Panu** [FI/FI]; Siltakulänkuja 1C25, FI-00740 Helsingfors (FI). **NIEMELÄ, Erik** [FI/FI]; Hytintie 79, FI-60550 Nurmo (FI). **LÄNSIKALLIO, Juha-Matti** [FI/FI]; Tampereentie 320, FI-61680 Mantila (FI). **TEGSTRÖM, Jonas** [SE/SE]; Ramstorpsgatan 30, S-58245 Linköping (SE).

Published:

— with international search report (Art. 21(3))

(54) Title: COIL PACKAGING SYSTEM

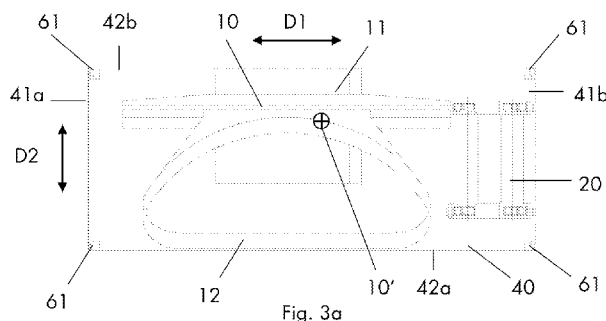

(57) Abstract: The present invention is providing a whole coil packaging system comprising a coil wrapping machine (10) comprising a frame (11), a wrapping ring (12) and a wrapping head (13) arranged to rotate around the wrapping ring (12). Further the system comprises a coil rotating means (20) adapted to carry and to rotate a coil (50). The invention is characterized in that the coil wrapping machine and the coil rotating means are both attached to one transportable platform (40). The packaging system is compact, transportable and adapted to easily be unloaded and quickly to be taken into production use.

WO 2011/115548 A1

COIL PACKAGING SYSTEM

Technical field

[0001] The present invention relates generally to a coil packaging system comprising a coil wrapping device.

Background art

[0002] Packing of sensitive goods by wrapping them with an impervious, stretchable wrapping medium, for example a stretch wrap plastic film, has been known for many years. When using this wrapping method the goods are protected against corrosion or soiling during transport and handling. Even large articles, such as coils of steel strip, are packaged with this method. However, packaging of coils of steel strip is particularly difficult due to their shape, size and weight. In order to fully wrap the coil still leaving an open center to receive coil handling equipment a method called through-the-eye wrapping has been developed.

[0003] In prior art US5282347 and WO2007/128885 such through-the-eye wrapping devices are described.

[0004] In US5282347 the wrapping device comprises spool holder, on which the wrapping medium is attached. The spool holder is mounted on a shuttle able to ride around a loop structure defining an endless stationary track enclosing and stretching through center of the coil. The loop structure is mounted in one of its sides on a portal type support structure and is able to move in the vertical direction. When loading a coil to be wrapped the loop structure is opened in one end and the coil is delivered in place by a trolley running on rails in the floor.

[0005] This wrapping device is large and heavy. It is also firmly attached to the floor of the facility and requires an advanced rail structure delivering the coils.

[0006] The wrapping device/machine disclosed in WO2007/128885 has a different structure where the loop structure or wrapping ring is mounted on a frame and can be opened both from above and from the sides. Further, the wrapping ring can be pivoted around a horizontal axis, opening up for the delivery of the coil to a rotation roller either connected to the machine or moveable. Thus, this construction facilitates feeding and removal of the coils to be wrapped. The machine is also small and simple.

[0007] However, this device still is constructed for a facility or a part of a facility specially adapted to the wrapping process. The machine is preferably placed at the facility for a long period of time and is mainly used in large volume manufacturing. A need of a more flexible solution for small volume manufacturing customers has arisen.

Summary of invention

[0008] An object of the present invention is to provide a whole coil packaging system comprising a coil wrapping device and all for the operation useable machinery, as claimed in claim 1. The packaging system shall be compact, transportable and adapted to easily be unloaded and taken into production use in a matter of hours.

[0009] The coil packaging system in claim 1 comprises a coil wrapping device comprising a frame, a wrapping ring and a wrapping head arranged to be guided along the wrapping ring. Further the system comprises a coil rotating means adapted to carry and to rotate the coil. The invention is characterized in that the frame of the coil wrapping device and the coil rotating means are both attached to one transportable platform and that and that the wrapping ring is arranged in a first position having a first direction in relation to the transportable platform during

transport and a second position having a second direction in relation to the transportable platform during operation.

[00010] By attaching both the coil wrapping device and the coil rotation means to one platform a compact and portable wrapping system is created forming one single entity that includes all necessary features for wrapping a coil with stretchable wrapping medium. When the wrapping ring alone or the entire wrapping device has a possibility to rotate between a first transporting position and a second operation position the whole system can be made more compact during transport and still be aligned with the coil rotating means during operation.

[00011] In a preferred embodiment of the invention the wrapping ring is arranged to rotate around an essentially vertical rotation axis in relation to the transportable platform.

[00012] By arranging the wrapping ring rotatable it is possible to align the ring with the coil rotating means, thus optimizing the wrapping process.

[00013] In an embodiment of the coil packaging system the frame of the coil wrapping device is rotatably attached to the transportable platform and in another embodiment of the coil packaging system the wrapping ring is rotatably attached to the frame and is arranged to rotate around the rotation axis.

[00014] In a further embodiment the transportable platform has a rectangular shape limited by first and second short outer edges and first and second long outer edges and where the first direction of the wrapping ring is a direction essentially parallel to the long edges of the platform and the second direction of the wrapping ring is a direction essentially transversal to the long edges of the platform. Preferably, the coil wrapping device is arranged essentially inside all the outer edges of the transportable platform when in its first transporting position.

[00015] A platform with a rectangular shape is easy to transport, for example on a commercial vehicle or a train, and since a wrapping device of known type usually is wider in one direction a preferred transporting direction of the device is parallel to the long edge of the platform.

[00016] In further embodiments the packaging system is provided with more features useable for the operation. In the embodiments all or one of the following features is attached to the transportable platform; an operator panel, an electric central, a tool box and/or a safety system.

[00017] From the operator panel the semi-automatic functions of the device are controlled. The operator panel is preferably a stand-alone panel. By including an electric central to the packaging system the device is quickly installed since it can be directly attached to the facility's power net. The tool box is preferably including all necessary tools for operating the device. Further, it is also possible to store a machine cover in the box. The machine cover may be a tarpaulin adapted to cover the whole packaging system, preferably resting on a frame construction. To protect the operator and other persons in the vicinity of the device a safety system may also be included.

[00018] In a first embodiment the safety system comprises a foldable fence adapted to at least partly encircle the coil wrapping device and coil rotating means when in the second operating position. The foldable fence is preferably encircling three sides of the system and may also have an optical barrier on the fourth side. The fence is stopping persons from being too close to the machine but it is still possible to reach the device by entering through the optical barrier.

[00019] In another embodiment the safety system comprises a safety laser system. With the safety laser system the fence to keep persons out is replaced by a

laser creating an optical barrier around the device and the coil rotating means. The safety laser system creates a non-contact monitoring of a freely programmable area.

[00020] In a further embodiment also the coil rotating means is rotatably attached to the transportable platform. If the coil rotating means has a possibility of rotating in relation to the platform and thus also in relation to the wrapping device, the delivery of the coil to the rotating means is facilitated. It is then possible to use different types of delivery vehicles with carrying means not limited to deliverance in a direction exactly in line with the wider direction of the wrapping device.

[00021] In a further preferred embodiment the transportable platform is adapted to be fitted into a container and/or to be the bottom of the container. The container may have foldable and/or removable walls and/or ceiling which are encircling the coil packaging system when in transport position.

[00022] Using a transport platform with a size adapted to a standard size container, preferably a 20 feet container having the dimensions 2440 mm x 6000 mm, is further simplifying the transport of the entire packaging system. The whole platform may then be easily loaded into and unloaded out of the container. If foldable walls and/or ceiling is used it is even more simple to take the device into production. The covering of the platform can also be a frame construction covered with a tarpaulin.

[00023] In a further embodiment the rotation of the coil wrapping device and/or the coil rotating means is manually or automatically performed. The possibility to be able to use either manual or automatic control of the rotation of the device and/or the coil rotating means opens up for the customer to customize the system after his/her needs. The system may then be fully or semi-automatic.

Brief description of drawings

[00024] The invention is now described, by way of example, with reference to the accompanying drawings, in which:

fig. 1 discloses a side view of the coil packaging system in a second operational position,

fig. 2 discloses a top view of the coil packaging system in a second operational position,

fig. 3a discloses a top view of a first embodiment of the coil packaging system in a first transport position,

fig. 3b discloses a top view of a second embodiment of the coil packaging system in a first transport position,

fig. 4 discloses a side view of the coil packaging system in a first transport position,

fig. 5 discloses a top view of a second embodiment of the packaging system,

fig. 6 and 7 discloses side views of the packaging system in different modes of operation with a first safety system and

fig. 8a and 8b discloses an embodiment of the packaging system having a second safety system.

Description of embodiments

[00025] In the following, a detailed description of the coil packaging system is disclosed. All examples herein should be seen as part of the general description and therefore possible to combine in any way in general terms. Again, individual features of the various embodiments may be combined or exchanged unless such

combination or exchange is clearly contradictory to the overall function of the system.

[00026] Figures 1 and 2 shows a side view and a top view of the coil packaging system including the wrapping device 10, coil rotating means 20 and all for the operation necessary machinery 30 attached to one transportable platform 40. An operator O is also disclosed in figure 1.

[00027] The wrapping device/wrapping machine 10 includes three main components. The frame 11 of the wrapping device 10, a wrapping ring 12 and at least one wrapping head 13 arranged to be guided along the wrapping ring 12. On the wrapping head 13 the wrapping material is placed.

[00028] The wrapping ring 12 is preferably oval in shape, but it can also be, for example, a rectangle with suitably rounded corners. Thus, the wrapping ring 12 is extending more in one direction and is having its longer extension direction essentially parallel to the horizontal plane. The piece being wrapped using the wrapping device 10 is a cylindrical coil 50, preferably of sheet metal. The coil 50 being wrapped has a centre hole 51, through which the closed wrapping ring 12 runs when wrapping the coil 50. The wrapping material can be, for example, a band of plastic or paper, which is intended to protect the coil 50 during transportation and storage.

[00029] The wrapping machine is in figure 2 shown in its first operational mode, where the wrapping ring is closed fully encircling the coil.

[00030] The packaging system further comprises coil rotating means 20 adapted to carry and to rotate the coil 50 around its longitudinal axis 51' during wrapping. In the case according to the embodiment described, the means consist of a set of rotation rollers 21. The set of rollers 21 consists of two elongated rollers

21a, 21b mounted to rotate on shafts, on top of which the cylindrical coil 50 being wrapped can be rotated around its longitudinal axis while wrapping is performed.

[00031] The coil rotating means 20 can be firmly or rotatably attached to the transport platform 40 at a distance determined by the size and shape of the wrapping ring 12. In figure 5 an embodiment of the system with a rotatably attached rotating means is disclosed.

[00032] In figure 1, when the wrapping device 10 is in a first operational mode the wrapping arm 12 is in an essentially horizontal direction with the wrapping arm 12 centered in the hole 51 through the coil 50. In figure 1 the device 10 is adapted to wrap coils 50 having a relatively small diameter.

[00033] In figure 6 the device 10 is disclosed adapted to wrap coils 50 of a larger diameter. Here the frame 11 is vertically raised so that the horizontally arranged wrapping arm 12 is centered in center hole 51 of the larger coil.

[00034] In figure 5 the device is disclosed in a loading mode where the wrapping ring 12 is open. The wrapping ring 12 is divided into two half rings, 12a and 12b. Both half rings 12a, 12b, can be moved in opposite directions in the horizontal plane, i.e. out from inside the centre hole 51 in the axial direction of the coil 50 being wrapped, when the wrapping ring 12 is in the wrapping position.

[00035] The wrapping ring 12 is pivoted rotatably to the frame 11 at pivot points 11a, 11b, which is visualized in figures 4 and 7. In figure 7 the wrapping ring 12 is shown in an essentially vertical position which opens up the machine and makes it possible to load the device with coils also directly from above. In figure 4 the wrapping ring 12 is shown in a position approximately 45 degrees from the horizontal plane. Other positions are also possible.

[00036] The transportable platform 40 has a rectangular shape limited by first and second short outer edges 41a, 41b and first and second long outer edges 42a, 42b. The short outer edges 41a, 41b of the platform is between 2000 and 3000 mm, preferably 2440 mm, and the longer outer edges 42a, 42b of the platform 40 is between 5500 mm and 6500 mm, preferably 6000 mm. The dimension of the platform 40 is preferably adapted to fit into a standard 20 feet container 60. The container 60 may have foldable and/or removable walls and/or ceiling 61, 62 which are encircling the coil packaging system when in the first transport position. The walls 61 and ceiling 62 can also be a frame construction covered with a tarpaulin.

[00037] In figure 3a it is shown an embodiment of the invention where the frame 11 of the wrapping device 10 is rotatably attached on the platform 40 and the device is here in a first position P1 with the wrapping ring 12 in a direction parallel to the longer edges 42a, 42b of the platform 40. Thus, the whole wrapping device 10 can rotate around a vertical rotation axis 10' between a first position P1 having a first direction D1 in relation to the platform and a second position P2 having a second direction D2 in relation to the platform 40. The first direction D1 is a direction where the extension direction of preferably oval wrapping ring 12 is essentially parallel to the longer edges 42a, 42b of the platform 40 and the second direction D2 is a direction where the wrapping ring 12 is essentially transversal to the longer edges 42a, 42b of the platform.

[00038] In figure 3b a second embodiment of the invention is shown, where instead the wrapping ring 12 is rotatably attached to the frame 11 which in turn is firmly mounted on the platform 40. Thus, the wrapping ring 12 rotated in relation to the frame 11 around the vertical rotation axis 10'' between the first position P1 and the second position P2.

[00039] For the device in its second operational position see figures 2, 5 and 8b.

[00040] In figure 4 it is shown that the wrapping arm 12 is arranged in a position approximately 45 degrees from the horizontal plane. The angle of the arm 12 is varying due to the size of the platform 40 and is adapted so that the arm 12 is keeping a position inside a vertical extension of the long outer edges 42a, 42b of the platform 40.

[00041] The rotation axis 10' of the first embodiment, shown in figure 3a, is preferably arranged coaxially in a rotation joint 43a of a suitable construction connecting the platform 40 and the frame 11 of the wrapping device 10. The rotation axis 10'' of the second embodiment, shown in figure 3b, is preferably arranged coaxially in a rotation joint 43b instead connecting the wrapping ring 12 and the frame 11. Both joint 43a and joint 43b are disclosed in figure 4, however only one of the two rotation joints is used in the respective embodiment. The rotation axis 10' and the rotation axis 10'' do not have to be coaxial.

[00042] The rotation joint 43a, 43b is for example placed at a position approximately centred between the short edges 41a, 41b of the platform and off-centre between the long edges 42a, 42b of the platform. The placement of the rotation joint 43a, 43b is preferably chosen so that the platform area is optimally used and so that the wrapping device 10 is inside the platform area both during transport, rotation and use. Further, the wrapping device 10 is so mounted on the platform that frame 11 or the wrapping ring 12 can freely rotate in relation to the for the operation useable machinery 30 which also is attached to the platform and thus included in the packaging system.

[00043] The, for the operation useable machinery 30 is specially marked in figures 5-8b and are preferably one or all of a standalone operator panel 31, an

electric central 32, a tool box 33 and/or a safety system 34. From the operator panel 31 the semi-automatic or fully automatic functions of the device 10 are controlled. By including an electric central 32 to the packaging system the device 10 is quickly installed since it can be directly attached to the facility's power net. The tool box 33 is preferably including all necessary tools for operating the machine. Further, it is also possible to store a machine cover in the box. The machine cover may be a tarpaulin adapted to cover the whole packaging system, preferably resting on a frame construction. To protect the operator and other persons in the vicinity of the device a safety system may also be included.

[00044] The safety system, as disclosed in figures 5-7, comprises a foldable fence 34a adapted to at least partly encircle the coil wrapping device and coil rotating means when it is in its second operating position. The foldable fence 34a is preferably encircling three sides of the system and may also have an optical barrier 34a' on the fourth side. The fence is stopping persons from being too close to the device but it is still possible to reach the device by entering through the optical barrier.

[00045] The safety system, disclosed in figures 8a and 8b, comprises a safety laser scanning system 34b. The safety system 34b is placed on a telescopic or foldable part 35 and scans a preprogrammed danger zone A1 of the device 10 and when a person is reaching the zone A1 the operator O is warned of the potential danger or the device is stopped directly. The operator O can move freely in an area around the operator panel 32. To allow the device to move without causing warning signals a second zone A2 inside the danger zone A1 is preprogrammed not to create a warning. Thus, the laser is creating an optical barrier around the device and the coil rotating means. The safety laser system 34b creates a non-contact monitoring of a freely programmable area A1, A2.

[00046] When the coil wrapping device 10 is in its first position P1 it is arranged essentially inside all the outer edges 41, 42 of the transportable platform 40. When in this position the coil packaging system may be easily transported, preferably by arranging the system in a regular container 60. Thus the whole system can be loaded on a transport vehicle as one entity and easily delivered to coil manufacturing facilities. When in place the device is rotated from its transport position, fig 3, to its operational position, figure 2, either automatically or manually. Because a complete system is delivered the device/machine is easily installed and quickly taken into production.

CLAIMS

1. A coil packaging system comprising:

a coil wrapping device (10) comprising a frame (11), a wrapping ring (12) and a wrapping head (13) arranged to be guided along the wrapping ring (12),

a coil rotating means (20) adapted to carry and to rotate a coil (50),

characterised in that the frame (11) of the coil wrapping device (10) and the coil rotating means (20) are both attached to one transportable platform (40) and that the wrapping ring (12) is arranged in a first position (P1) having a first direction (D1) in relation to the transportable platform (40) during transport and a second position (P2) having a second direction (D2) in relation to the transportable platform (40) during operation.
2. Coil packaging system according to claim 1, wherein the wrapping ring (12) is arranged to rotate around an essentially vertical rotation axis (10', 10'') in relation to the transportable platform (40).
3. Coil packaging system according to claim 2, wherein the frame (11) of the coil wrapping device (10) is rotatably attached to the transportable platform (40) and is arranged to rotate around the rotation axis (10').
4. Coil packaging system according to claim 2, wherein the wrapping ring (12) is rotatably attached to the frame (11) and is arranged to rotate around the rotation axis (10'').
5. Coil packaging system according to any of the above claims, wherein the transportable platform (40) has a rectangular shape limited by first and second short outer edges (41a, 41b) and first and second long outer edges (42a, 42b) and

where the first direction (D1) of the wrapping ring (12) is a direction essentially parallel to the long edges (42a, 42b) of the platform (40) and the second direction (D2) of the wrapping ring (12) is a direction essentially transversal to the long edges (42a, 42b) of the platform (40).

6. Coil packaging system according to claim 5, wherein the coil wrapping device (10) is arranged essentially inside all the outer edges (41a, 41b; 42a, 42b) of the transportable platform (40) when in its first transporting position (P1).

7. Coil packaging system according to any of the above claims, wherein an operator panel (31) and/or an electrical central (32) is included in the packaging system and attached to the transportable platform (40).

8. Coil packaging system according to any of the above claims, wherein a tool box (33) is included in the packaging system and attached to the transportable platform (40).

9. Coil packaging system according to any of the above claims, wherein a safety system (34) is included in the packaging system and attached to the transportable platform (40).

10. Coil packaging system according to claim 9, wherein the safety system (34) comprises a foldable fence (34a) adapted to at least partly encircle the coil wrapping device (10) and coil rotating means (20) when in the second operating position.

11. Coil packaging system according to claim 9 or 10, wherein the safety system (34) comprises a safety laser system (34b).

12. Coil packaging system according to any of the above claims, wherein the coil rotating means (20) is rotatably attached to the transportable platform (40).

13. Coil packaging system according to any of the above claims, wherein the transportable platform (40) is adapted to be fitted into a container (60) and/or be the bottom of the container (60).
14. Coil packaging system according to claim 13, wherein the container (60) has foldable and/or removable walls and/or ceiling (61, 62) encircling the coil packaging system when in the first transport position (P1).
15. Coil packaging system according to any of the above claims, wherein the rotation of the coil wrapping device (10) and/or the wrapping ring (12) and/or the coil rotating means (20) is manually or automatically performed.

1/4

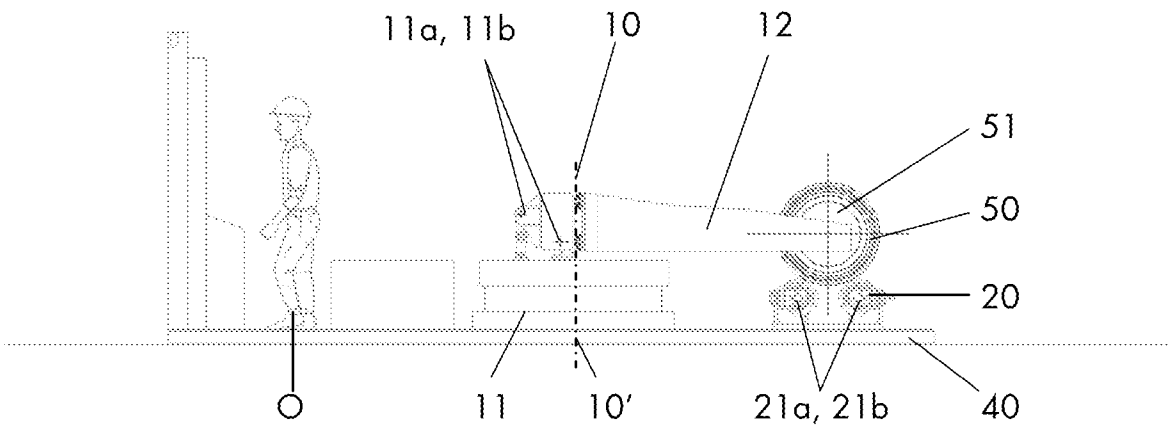

Fig. 1

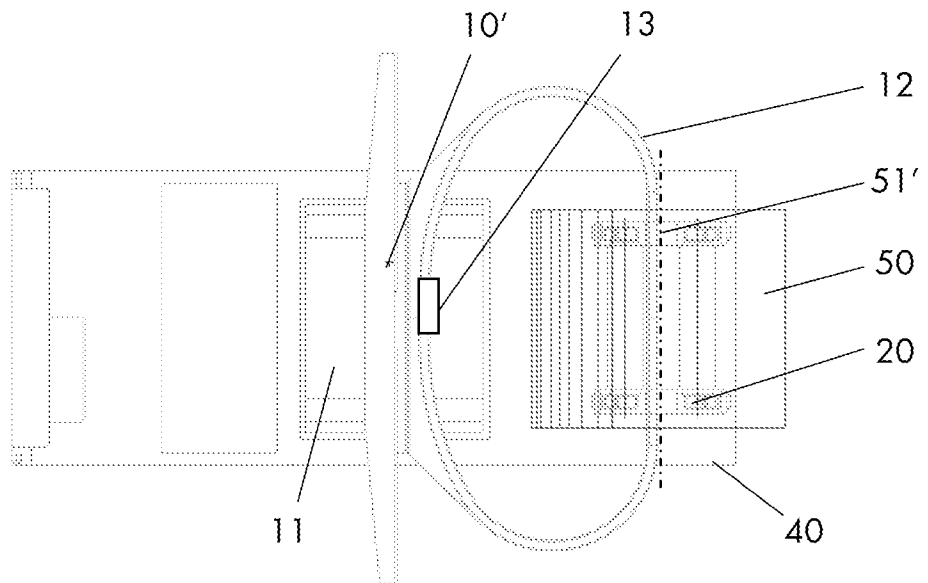

Fig. 2

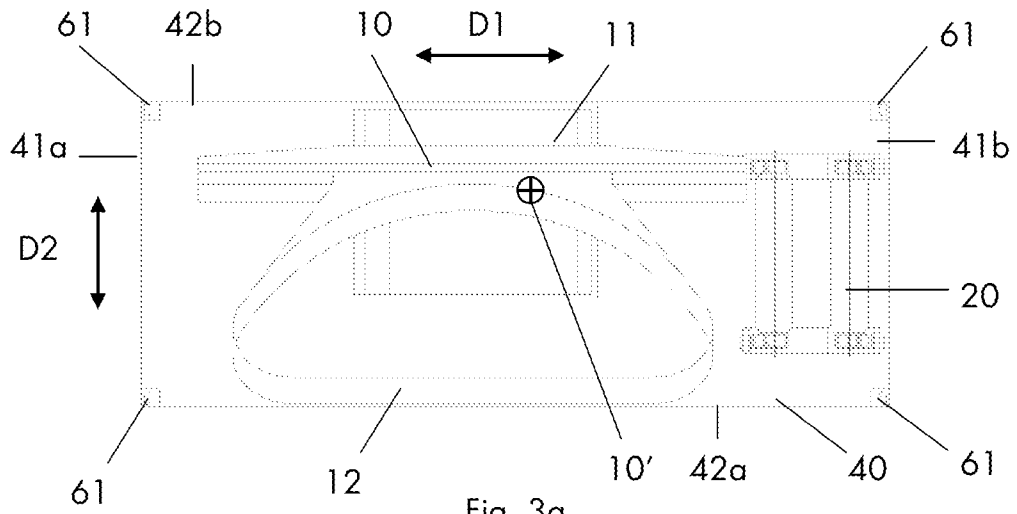

Fig. 3a

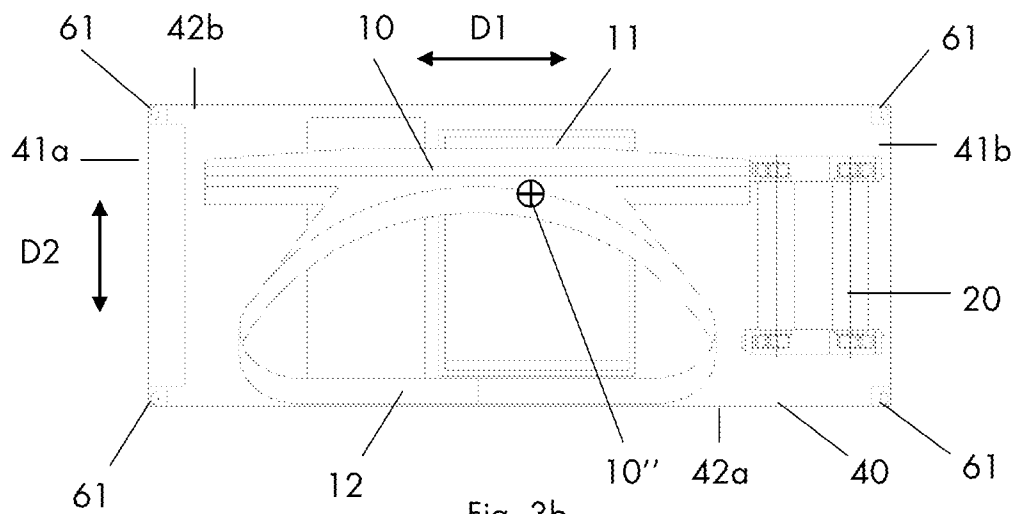

Fig. 3b

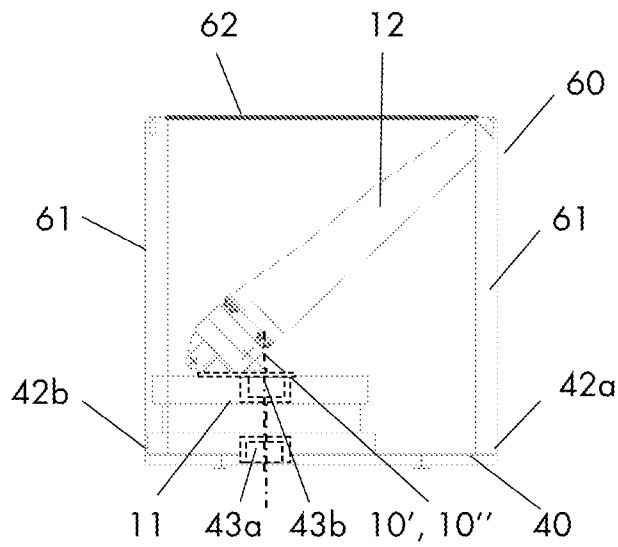
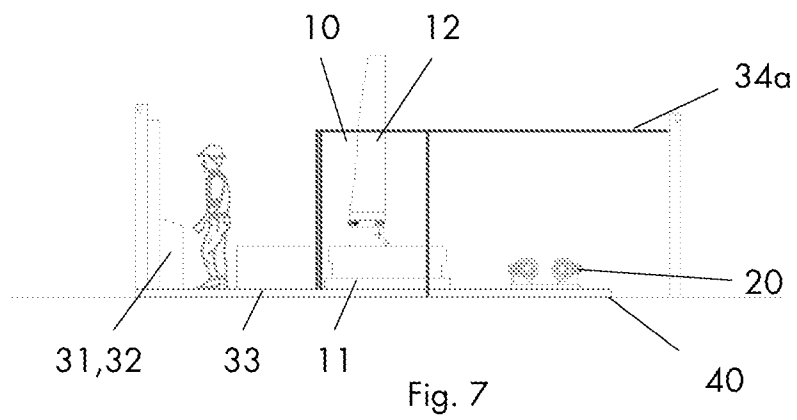
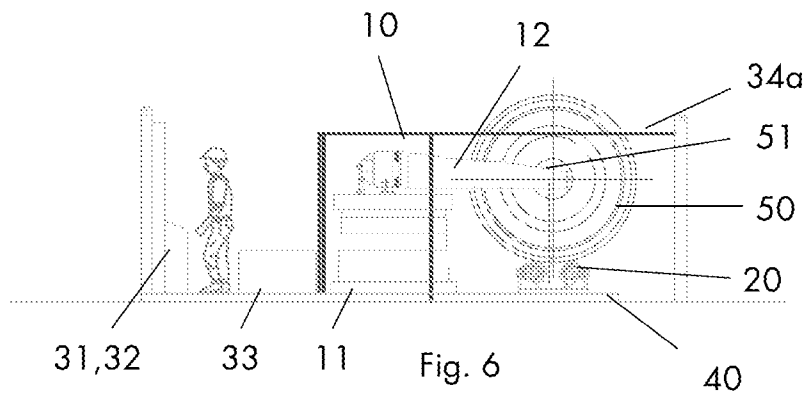
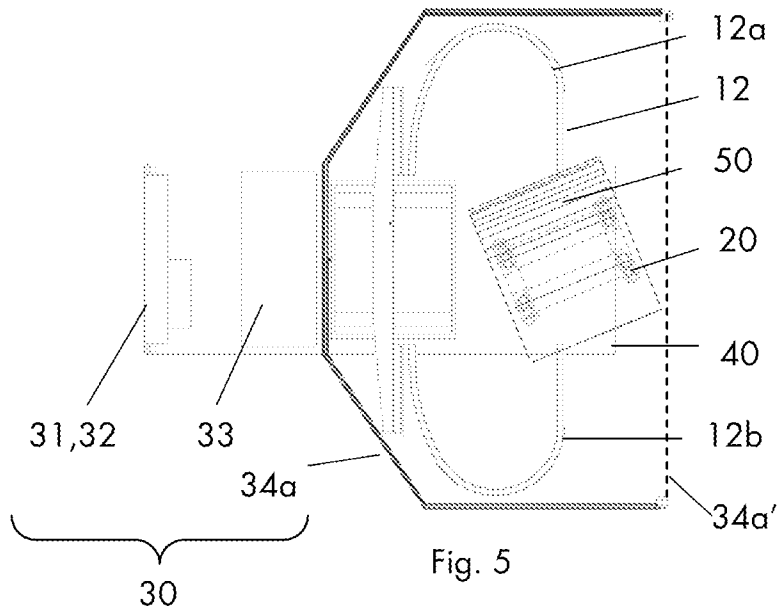
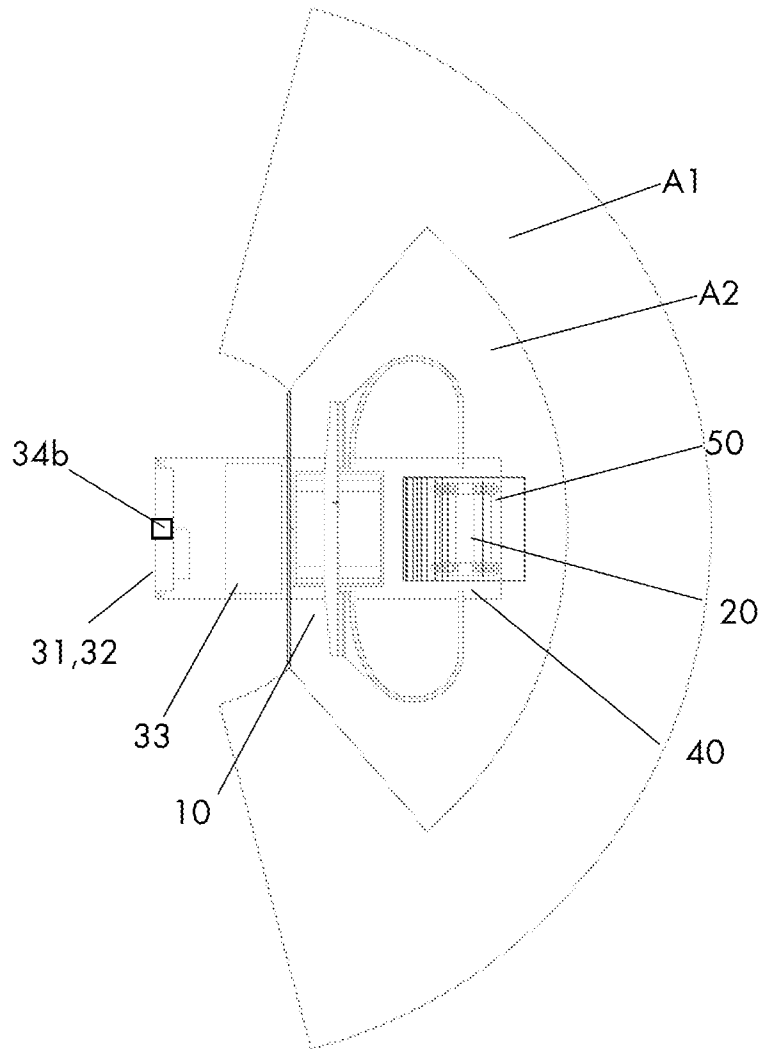
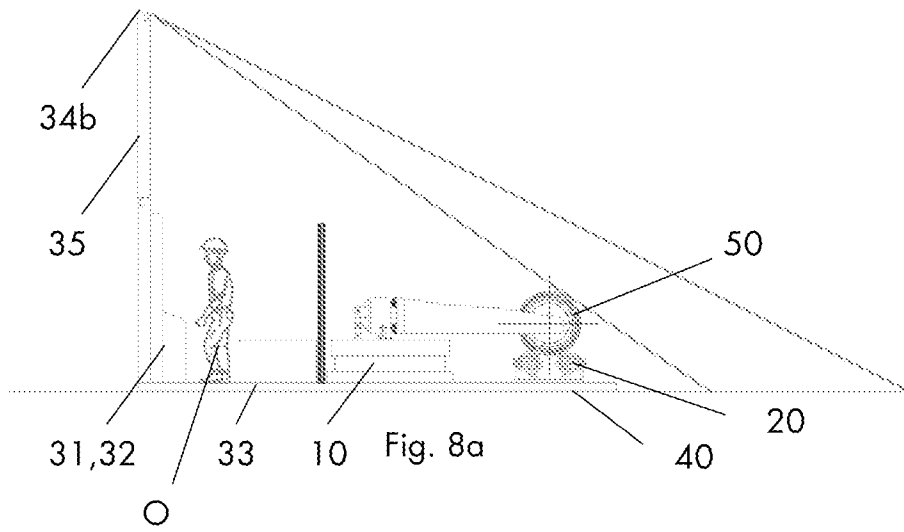

Fig. 4





INTERNATIONAL SEARCH REPORT

International application No.
PCT/SE2011/050265

A. CLASSIFICATION OF SUBJECT MATTER

IPC: see extra sheet

According to International Patent Classification (IPC) or to both national classification and IPC

B. FIELDS SEARCHED

Minimum documentation searched (classification system followed by classification symbols)

IPC: B65B

Documentation searched other than minimum documentation to the extent that such documents are included in the fields searched

SE, DK, FI, NO classes as above

Electronic data base consulted during the international search (name of data base and, where practicable, search terms used)

EPO-Internal, PAJ, WPI data

C. DOCUMENTS CONSIDERED TO BE RELEVANT

Category*	Citation of document, with indication, where appropriate, of the relevant passages	Relevant to claim No.
A	US 4829753 A1 (BRICMONT), 16 May 1989 (1989-05-16); whole document --	1-15
A	WO 9636535 A1 (COMPANHIA SIDERÚRGICA NACIONAL), 21 November 1996 (1996-11-21); abstract; figure 3; detail 69 --	1-15
A	WO 0142085 A1 (ARAUJO, LUIZ HENRIQUE), 14 June 2001 (2001-06-14); abstract --	1-15
A	DE 1244045 B1 (HANS BÖHL MASCHINENFABRIK), 6 July 1967 (1967-07-06); whole document --	1-15

 Further documents are listed in the continuation of Box C. See patent family annex.

* Special categories of cited documents:

"A" document defining the general state of the art which is not considered to be of particular relevance

"E" earlier application or patent but published on or after the international filing date

"L" document which may throw doubts on priority claim(s) or which is cited to establish the publication date of another citation or other special reason (as specified)

"O" document referring to an oral disclosure, use, exhibition or other means

"P" document published prior to the international filing date but later than the priority date claimed

"T" later document published after the international filing date or priority date and not in conflict with the application but cited to understand the principle or theory underlying the invention

"X" document of particular relevance; the claimed invention cannot be considered novel or cannot be considered to involve an inventive step when the document is taken alone

"Y" document of particular relevance; the claimed invention cannot be considered to involve an inventive step when the document is combined with one or more other such documents, such combination being obvious to a person skilled in the art

"&" document member of the same patent family

Date of the actual completion of the international search

13-06-2011

Date of mailing of the international search report

16-06-2011

Name and mailing address of the ISA/SE

Patent- och registreringsverket
Box 5055
S-102 42 STOCKHOLM
Facsimile No. + 46 8 666 02 86

Authorized officer

Kristina Berggren

Telephone No. + 46 8 782 25 00

INTERNATIONAL SEARCH REPORT

International application No.
PCT/SE2011/050265

C (Continuation). DOCUMENTS CONSIDERED TO BE RELEVANT

Category*	Citation of document, with indication, where appropriate, of the relevant passages	Relevant to claim No.
A	WO 2007128885 A1 (KNA CORPORATION OY), 15 November 2007 (2007-11-15); abstract; page 13, line 10 - line 13; figures 4,5 --	1-15
A	WO 0170575 A1 (INTERGRATED INDUSTRIAL SYSTEMS), 27 September 2001 (2001-09-27); abstract --	1-15
A	EP 1464579 A2 (OCTOMECA OY), 6 October 2004 (2004-10-06); abstract; paragraph [0032]; figure 20 -- -----	1-15

Continuation of: second sheet

International Patent Classification (IPC)

B65B 27/06 (2006.01)

B65B 11/04 (2006.01)

B65B 25/24 (2006.01)

Download your patent documents at www.prv.se

The cited patent documents can be downloaded:

- From "Cited documents" found under our online services at www.prv.se
(English version)
- From "Anförda dokument" found under "e-tjänster" at www.prv.se
(Swedish version)

Use the application number as username. The password is **VXUWAHZLJJ**.

Paper copies can be ordered at a cost of 50 SEK per copy from PRV InterPat (telephone number 08-782 28 85).

Cited literature, if any, will be enclosed in paper form.

INTERNATIONAL SEARCH REPORT

Information on patent family members

International application No.

PCT/SE2011/050265

US	4829753 A1	16/05/1989	NONE		
WO	9636535 A1	21/11/1996	BR	9501848 A	12/08/1997
WO	0142085 A1	14/06/2001	AU	2213101 A	18/06/2001
			CA	2392688 A1	14/06/2001
			DE	60009138 D1	22/04/2004
			EP	1237785 A1	11/09/2002
			MX	PA02005629 A	18/09/2002
DE	1244045 B1	06/07/1967	NONE		
WO	2007128885 A1	15/11/2007	EP	2015993 A1	21/01/2009
			US	20090158692 A1	25/06/2009
WO	0170575 A1	27/09/2001	AU	4774001 A	03/10/2001
			US	6324820 B1	04/12/2001
EP	1464579 A2	06/10/2004	AT	361232 T	15/05/2007
			DE	602004006184 T2	03/01/2008
			FI	113361 B1	15/04/2004
			US	7134260 B2	14/11/2006
			US	20040231302 A1	25/11/2004