

J. JOHNSON.

Improvement in Pressure-Regulators for Water-Pipes.
No. 128,492.

Patented July 2, 1872.

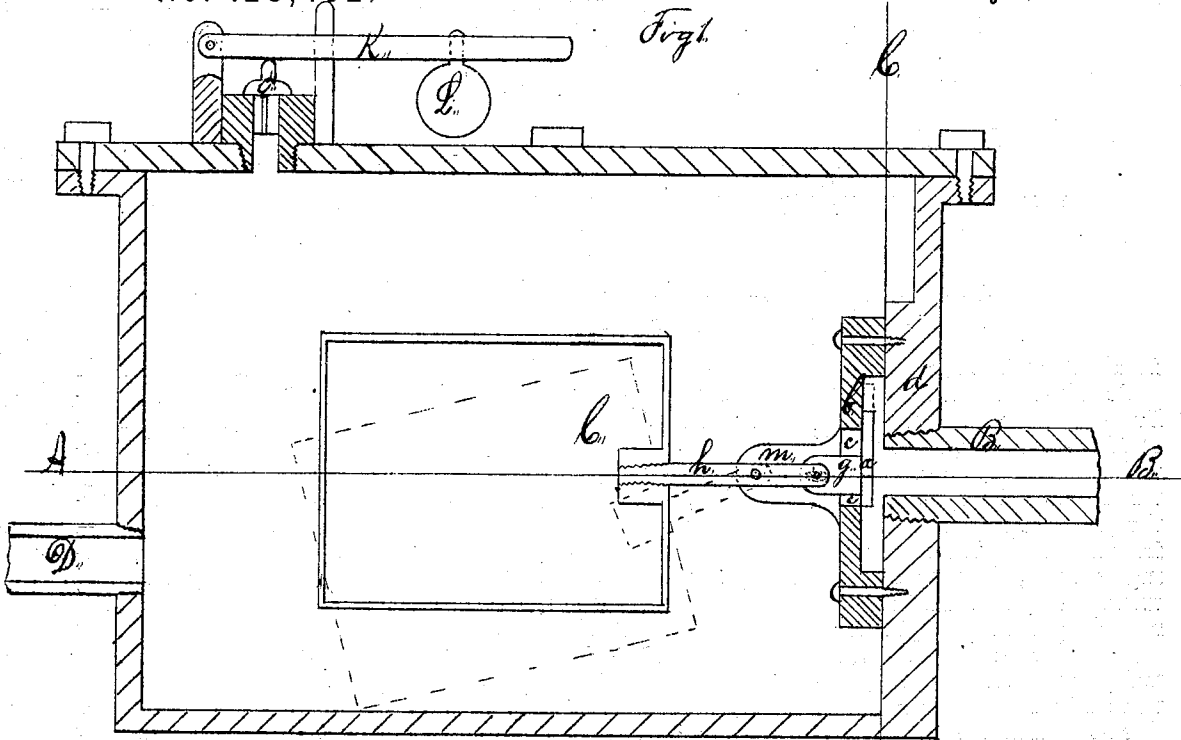

Fig. 1.

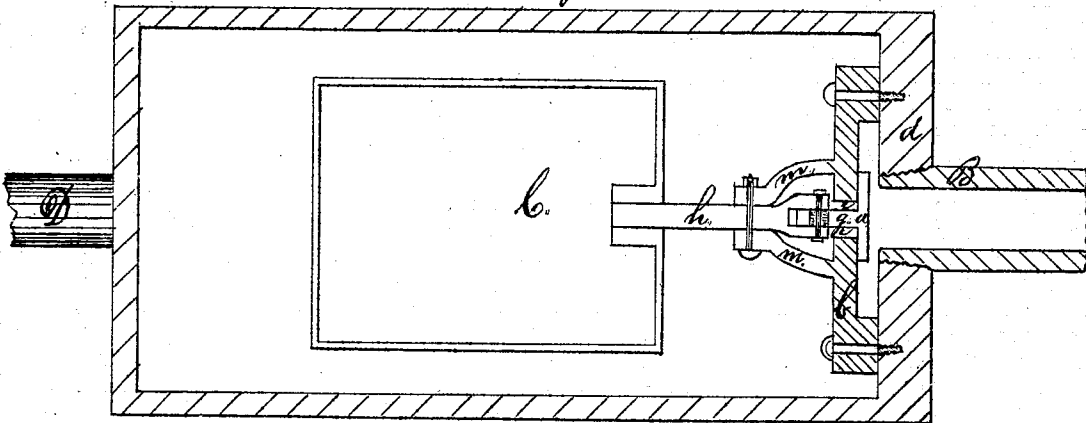
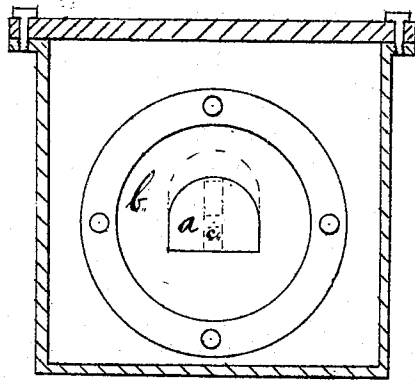

Fig. 2.



Witnesses..

William H. Abel
John E. Crane

Inventor..

Jonathan Johnson

UNITED STATES PATENT OFFICE.

JONATHAN JOHNSON, OF LOWELL, MASSACHUSETTS.

IMPROVEMENT IN PRESSURE-REGULATORS FOR WATER-PIPES.

Specification forming part of Letters Patent No. 128,492, dated July 2, 1872.

To all whom it may concern:

Be it known that I, JONATHAN JOHNSON, of Lowell, in the county of Middlesex and State of Massachusetts, have invented certain new and useful Improvements in Pressure-Regulators for controlling or regulating the flow and the pressure of water passing through pipes from an elevated reservoir, of which the following is a full, clear, and exact description, reference being had to the accompanying drawing making part of this specification, in which—

Figure 1 represents a sectional elevation centrally and vertically; Fig. 2, a horizontal section; Fig. 3, a cross-section, the former on the line A B, and the latter on the line C D, of Fig. 1.

This invention has for its object to control and regulate the flow and the pressure of water passing from an elevated reservoir through pipes to the drawing-faucets in the different apartments in a house, shop, or mill, whereby the water which is at a high pressure in the supply-pipe may be drawn at a low pressure from the outlet, and whereby common and low-cost pipes may be employed for conducting the water at a low pressure to all parts of the building, instead of the more expensive pipes necessary to withstand the full and high pressure from the elevated reservoir or fountain.

Experiments have demonstrated that in drawing water through pipes from a considerably elevated reservoir, where the initial pressure is from twenty to fifty or one hundred or more pounds to the inch, the extreme force of the water subjects the user to great inconvenience and annoyance by its uncontrollable spitting and flaring action against the bottom and sides of the pan, bowl, or sink into which such strongly-forced water is drawn; and, besides this, if the conducting-pipes are of lead or gutta-percha, or other moderately-strong substance, they are liable to be burst and cause great annoyance and inconvenience, and damage to the structure and the fixtures and furnishings.

To provide a ready remedy for all the above-named difficulties, inconveniences, and annoyances, and to render the cheaper conducting-pipes as serviceable and as safe as the stronger and more expensive pipes, which, in some instances, would have to be substituted for the less expensive ones already the convenient

conveyances for water, I construct a suitable pressure-regulator, substantially as herein described, and this, or one or more of these, I apply to the supply-pipe, (or to connected branch-pipes,) and between it and the conducting-pipes, and at some convenient place for connecting the former with the latter, either inside or the outside of the building. This pressure-regulator consists of a strong air-tight case or tank, provided at one end or side with a suitable gate or a valve, *a*, which, in the present instance, is seated to the face of a recessed disk or plate, *b*, and arranged to cover or uncover an inlet or aperture, *c*, through the disk, and opposite, or nearly opposite, the delivery end of the supply-pipe B, which is connected with or screwed into the end *d* of the case. A valve-stem or rod, *g'*, extends inward from the gate, and connects loosely with the end of a lever, *h*, pivoted between two stands or brackets, *m*. The lever *h* is firmly attached to a float, C, arranged within the case, as shown. At the opposite end, or to either side of the tank or case, (or by a branch-pipe,) I apply one or more conducting-pipes, D, having greater capacity for the delivery of water than has the inlet *c* to supply it to the tank, so as to insure the rising and falling of the float to close or open the valve when drawing or ceasing to draw water. The upper portion of the case or tank above the inflowing water, and above and partly around the float, serves for an air-chamber, or to contain air in sufficient quantity to prevent the water filling the tank, and this is further prevented by means of the excess of outlet over that of the inlet, which keeps the water down and allows the air to remain in the tank; and this air-pressure, which may be of about fifteen pounds to the inch, regulates the pressure at which the water shall flow from the tank whatever may be the pressure through the supply-pipe and against the valve or through the inlet *c*, since the air-pressure can be varied by a safety-valve, *e'*, having a weighted lever, K, shown in Fig. 1 of the drawing.

When the pressure from the reservoir is great the weight L is moved to nearer the end of the lever, and the position of the weight is changed to accommodate almost any pressure from the reservoir, and thus regulate the flow of water at almost any desired reasonable pressure

through the conducting pipe or pipes and out at faucets thereon. The valve *c'* also provides for the escape of any excess of air in the tank, and thus keeps the pressure uniform. The injurious action of water-hammers, (so called,) caused by the sudden stoppage of the flow of water, is also prevented by the use of my improved regulator applied and used as described. The water from the connected and elevated reservoir passes through the supply-pipe B and into the tank at the aperture *c* in sufficient quantity to raise the float, which, by rising, operates the sliding valve *a* by means of the pivoted lever *h* connected with the rod *g*, and closes, or nearly closes, the aperture. Opening a faucet in a conducting-pipe allows the water to flow from the tank at first apparently by air-pressure, and this allows the float to fall and open the valve, or partially uncover the aperture, causing almost instant supply of water in the tank, but not in sufficient quantity to fully raise the float and close the valve, as the greater capacity of the outlet to deliver water keeps it low in the tank and prevents the float rising until the faucet is closed, when the water from the supply-pipe gradually rises in the tank and raises the float, and closes, or partially closes, the aperture *c*, as before, leaving the water in the tank at a pressure according to the position of the weight on the beam or lever K, and the float ready to fall and open the valve whenever water is drawn from a conducting-pipe.

Pipes intended to supply water to apartments on different floors in a building should

each be furnished with a separate regulator, having its lever K weighted differently, or the weight in a different position on the lever, so as to keep the air-pressure in each tank proportionate to the height or distance between the regulator and the outlet."

Instead of the valve *a* for opening and closing the aperture *c*, a balanced double puppet-valve, or any other common valve, arranged and connected with and operated by the rising and falling float, may be substituted for the one shown and described and still retain the principles and merits of my said invention.

When the pressure of water in the supply-pipe is limited—say, from ten to twenty or thirty pounds to the inch—the safety-valve *c'* may not be called into action; but I consider it best to apply this device, and then the regulator is adapted for varying pressures or where the pressure is greater.

I claim—

The pressure-regulator herein described, consisting of an air-tight tank, A, having induction and eduction pipes B and D, and embracing a combination of the valve *a*, operated by the float C, for governing the influx of water with the valve *c'*, lever K, and weight L for regulating the pressure at which it is discharged, all being constructed and arranged as and for the purpose shown and set forth.

JONATHAN JOHNSON.

Witnesses:

WILLIAM H. ABEL,
JOHN E. CRANE.