

M. ROBBINS.

Automatic Grain Weigher.

No. 47,247.

Patented April 11, 1865.

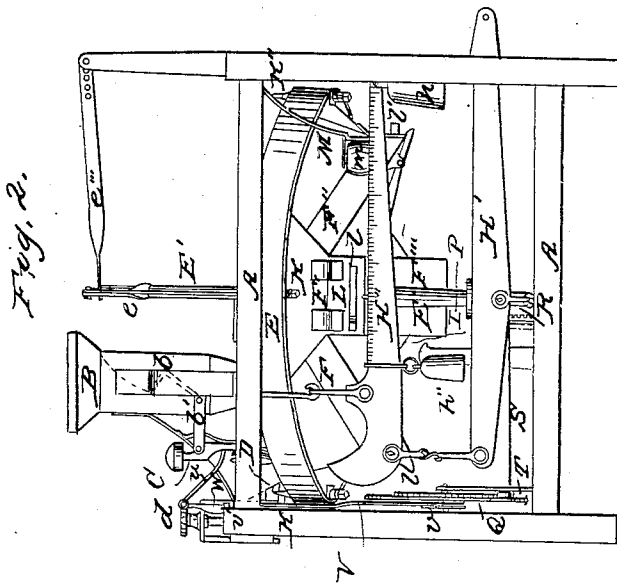
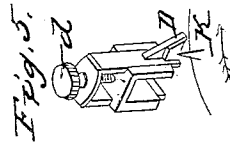
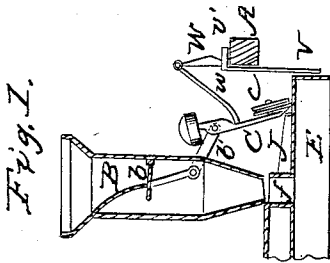

Witnesses:  
 James M. Gayman  
 W. H. Mackay

Inventor:  
 M. Robbins  
 J. L. Smith Bro  
 atty

M. ROBBINS.  
Automatic Grain Weigher.

No. 47,247.

Patented April 11, 1865.

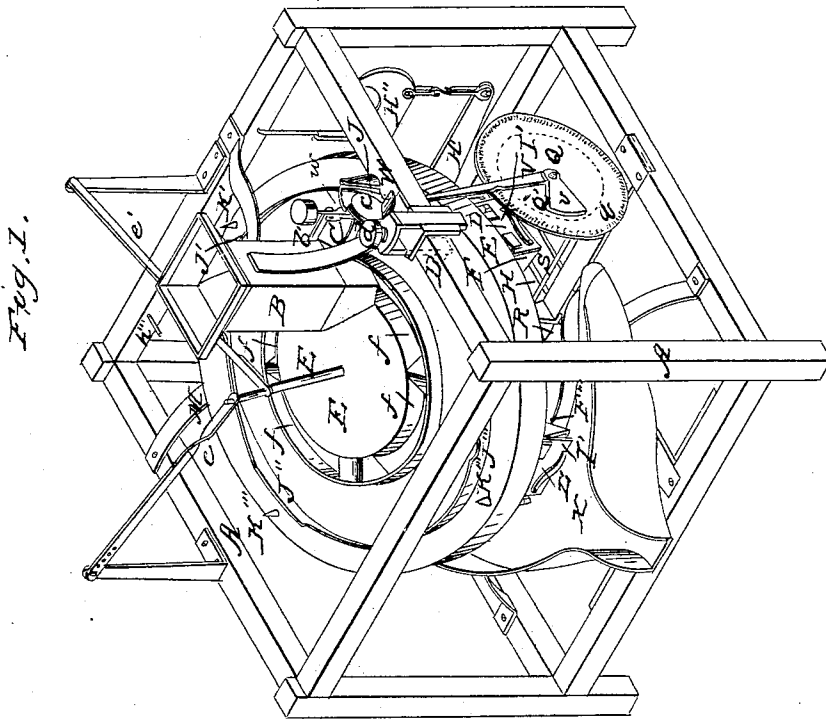
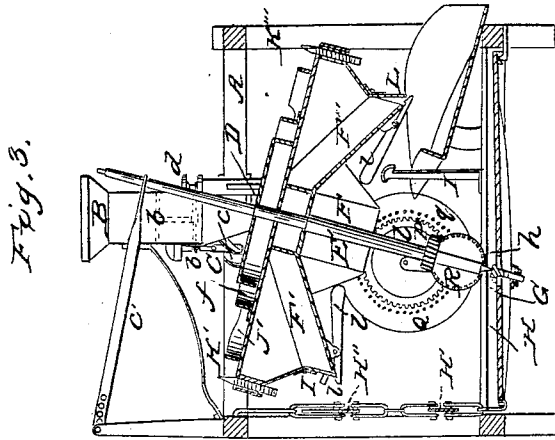

Witnesses:  
James W. Dayman  
W. H. Morley

Inventor:  
M. Robbins  
per L. P. & G. Bros  
attys

# UNITED STATES PATENT OFFICE.

MARTIN ROBBINS, OF CINCINNATI, OHIO, ASSIGNOR TO HIMSELF AND MAHLON M. WOMBAUGH, OF SAME PLACE.

## IMPROVEMENT IN AUTOMATIC GRAIN-WEIGHERS.

Specification forming part of Letters Patent No. 47,247, dated April 11, 1865.

*To all whom it may concern:*

Be it known that I, MARTIN ROBBINS, of Cincinnati, Hamilton county, State of Ohio, have invented a new and useful Improvement in Automatic Grain-Weighers; and I do hereby declare the following to be a full, clear, and exact description thereof, reference being had to the accompanying drawings, making part of this specification.

My improvement relates to the class of automatic grain-weighers which are impelled by the weight of the descending grain, and has for its object greater certainty, capacity, and facility of operation, together with such compact vertical dimensions as to admit beneath it a barrel or other customary receptacle, within the limits of an ordinary warehouse story.

Figure 1 is a perspective view of a machine embodying my improvements. Fig. 2 is a front elevation thereof. Fig. 3 is a transverse section. Fig. 4 is a section through the hopper and accompanying devices. Fig. 5 shows the controlling gage and stud detached.

A is a frame for support of the operating mechanism.

B is a hopper provided with a valve, *b*, said valve being operated by a lever, *b'*, attached to a loaded shaft, C, having a grooved roller, *c*, which is actuated by cams J J' J'' J'''.

D is a controlling stop or gage, capable of vertical adjustment on the frame A by means of a set-screw, *d*.

E is my revolving and gravitating drum or grain-meter, supported at the represented inclined position, the declination of its axis being about fifteen degrees. The drum E is of considerably greater diameter than its length, and is divided interiorly by two or more equidistant radial partitions into a suitable number of grain chambers or compartments, F F' F'' F'''. The foot of its shaft E' rests on an adjustable step or socket, G, which occupies a slot, *h*, in the lowest of a series of connected beams, H H' H'' whose construction and arrangement may be essentially those of a common hay-scales. The upper beam, H'', of the series is in the form of a steelyard, and has an adjustable weight, *h'*, for counterbalancing the empty meter or drum and its appendages, and another adjustable weight, *h''*, for the grain.

*h'''* is a stop for limiting the play of the steelyard. The upper end of the drum-shaft E' is maintained in its proper inclined position, and at the same time permitted to freely rise or sink in the line of its axis, by two vibrating rods, *e' e''*, situated at right angles to each other and to the said shaft, and hinged by their other extremities to the frame. Each grain-chamber has at its upper part a receiving funnel or mouth, *f*, and at its lower part a delivery-gate, L, gravitating catch *l*, and flexible tongue *l'*.

I is an inclined or wedge-formed stump, against which the gravitating catches *l* successively impinge, so as at the proper instant to open their respective delivery-gates, as hereinafter explained. Projecting upward from the top of the drum E are a series of equidistant studs, K K' K'' K''', one for each grain-chamber. Each of these studs is secured to the drum by a screw-shank, to enable its adjustment upward or downward, the degree of projection of each stud being just sufficient to temporarily arrest the rotation of the drum by lodging against the gage D, but so as to escape beneath the lower edge of the gage, D the instant that the prescribed weight of grain has sufficiently depressed the drum.

J J' J'' J''' are cams forming part of a circular flange which projects from the drum-top concentric with its axis. Each cam serves in succession to open and shut the receiving-valve *b* in the hopper B, through the medium roller *c*, shaft C, and lever *b'*. Each gate L, after having discharged its quantum of grain, is closed by the impingement of the flexible tongue *l'* against a projection, M, from the frame, which projection may, for greater ease of working, be provided with a friction roller, *m*.

In order to dispense with an attendant, and to guard against an incorrect delivery of grain, I have provided a self-acting governor, which effectually limits the action of the machine to the exact amount desired. For this purpose I provide the drum-shaft E' with a pinion, P, which causes the dial plate Q to revolve through the medium of a bevel-wheel, R, shaft S, pinion T, and spur-wheel U. The spur-wheel U is secured to the rear of the dial-plate Q, the latter being pierced by a number of equidistant holes, *q'*, numbered con-

successively from right to left, for the reception of a small pin, Q', whose insertion opposite the appropriate number causes the entire apparatus to stop on the delivery of the corresponding supply of grain, in manner presently explained.

V is a lever, loaded at *v* and terminating at top in a wedge-formed lifter, *v'*.

W is a gravitating pendant attached to the loaded shaft C by arm *w*.

The grain is discharged from the machine by a trough, X.

The operation of the machine is as follows: While one of the compartments or chambers is being filled with grain, the appropriate stud K is resting against the gage D, and in this position of the drum the grooved roller *c* is elevated to the highest part of one of the cams, J, thereby opening the valve *b* in the hopper B, which causes a continuous flow of grain into one of the chambers, F. When a chamber becomes filled, the weight of the grain depresses the drum E until the stud K escapes under the gage D, and the shaft E' being, as before stated, somewhat inclined from the perpendicular, the loaded chamber compels the drum to revolve, and as it revolves the gravitating catch *l* strikes the inclined stump I, thereby liberating the delivery-gate L, and allowing the grain to escape into the discharging-trough X. As soon as the stud K has passed under the gage D, the revolution of the drum E brings the lowest part of one of the cams, J, under the roller *c*, when the latter sinks and momentarily stops the flow of grain until one of the partitions which separate the chambers has passed under the hopper, and as soon as this partition is out of the way the succeeding cam, J', commences to lift the valve *b*, and to retain it open until the chamber is filled, and so on for the revolution of each and every chamber.

The amount of grain desired to be passed at each discharge is determined within a fraction by the position of the weight *h''*, and is finally adjusted to extreme nicety by elevating or depressing the gage D by means of the thumb-screw *d'*. The more the gage D is depressed the greater will be the weight of grain necessary to compel the stud K to pass under the said gage, and vice versa. The continued revolution of the drum brings each of the flexible tongues *l'* in successive contact with the friction-roller *m*, so as to close the delivery-gate L in time to receive the next charge of grain.

When it is desired that the machine shall stop of itself, after a certain number of bushels have been weighed, the pin Q' is inserted in the aperture in the dial-plate Q corresponding to the number selected, and as the drum

revolves its motion is communicated to the dial-plate until the pin Q' strikes the lever V and forces the lifter *v'* under the gravitating pendant W, which it elevates and by so doing throws the roller *c* from the cam J, so as to close the valve *b* and to cause an instant cessation of the grain-delivery. (See Fig. 4.)

For the measurement of large quantities of grain two or more dials may be annexed to the machine, the second one to measure hundreds of bushels, the third one to measure thousands, and so on.

Each dial may have its own disengaging-lever connected to the lever V, so as to stop the machine either at hundreds or at thousands of bushels.

The meter or grain-receiver being nicely balanced on the beams, and the latter resting on V-edges, the entire gravitating portion sinks or rises with the slightest change of its contents, entirely free from any abrupt or jarring movement.

The adjustment of the studs K K' K'' K''' is merely to correct any slight inaccuracy, and so that their points revolve in a common plane or orbit. They may be fixed projections from the drum.

I claim herein as new and of my invention—

1. The revolving and gravitating drum E E', supported and balanced in the represented inclined position, and containing two or more chambers or compartments, F F' F'' F''', for the automatic weighing of grain, substantially as set forth.

2. The provision, on an inclined gravitating grain-drum, of the cams J J' J'' J''' when combined with the devices *b b' C c*, or their equivalents, for the automatic opening and closing of the hopper-bottom, as set forth.

3. In the described combination with an inclined gravitating grain-drum armed with studs K K' K'' K''', or other suitable projections, the adjustable gage D *d*, substantially as represented, or any mechanical equivalent thereof.

4. The devices L, *l*, *l'*, I, and M, or their mechanical equivalents, for the automatic opening and closing of each successive grain-chamber, as set forth.

5. The self-acting governor, consisting of the parts P Q R S T U V W *w*, in the described combination with the parts *b b' C c*, or devices substantially equivalent, for the automatic arrest of the weighing action, as set forth.

In testimony of which invention I hereunto set my hand.

MARTIN ROBBINS.

Witnesses:

GEO. H. KNIGHT,  
JAMES H. LAYMAN.