



Europäisches Patentamt
European Patent Office
Office européen des brevets



Publication number: **0 443 319 B1**

EUROPEAN PATENT SPECIFICATION

- (45) Date of publication of patent specification: **05.04.95** (51) Int. Cl.⁸: **B65D 30/08**, B65D 33/14,
B65D 33/16, B65D 88/16
(21) Application number: **91100464.6**
(22) Date of filing: **16.01.91**

(54) **A flexible container for transporting and storing bulk cargo.**

(30) Priority: **25.01.90 FI 900411**

(43) Date of publication of application:
28.08.91 Bulletin 91/35

(45) Publication of the grant of the patent:
05.04.95 Bulletin 95/14

(84) Designated Contracting States:
AT BE CH DE DK ES FR GB GR IT LI LU NL SE

(56) References cited:

EP-A- 0 112 808	EP-A- 0 283 201
DE-A- 2 607 065	DE-A- 2 618 546
DE-U- 8 911 783	FR-A- 1 398 007
FR-A- 2 437 925	FR-A- 2 450 754
GB-A- 2 034 278	US-A- 2 307 181
US-A- 2 565 754	US-A- 2 972 791
US-A- 3 068 132	US-A- 4 194 652
US-A- 4 573 204	

(73) Proprietor: **Oy W. Rosenlew Ab**
Ulasoori
SF-28100 Pori 10 (FI)

(72) Inventor: **Nyman, Per**
Mestarintie 6
SF-28400 Ulvila (FI)

(74) Representative: **Tiedtke, Harro, Dipl.-Ing. et al**
Patentanwaltsbüro
Tiedtke-Bühling-Kinne & Partner
Bavariaring 4
D-80336 München (DE)

EP 0 443 319 B1

Note: Within nine months from the publication of the mention of the grant of the European patent, any person may give notice to the European Patent Office of opposition to the European patent granted. Notice of opposition shall be filed in a written reasoned statement. It shall not be deemed to have been filed until the opposition fee has been paid (Art. 99(1) European patent convention).

Description

The invention relates to a flexible container of fabric material for transporting and storing bulk cargo, which container comprises a shell, a bottom and a closable filling opening, which container can be lifted from its upper end, and the joints forming the container are made by seaming or gluing.

Such flexible containers, or so-called bulk sacks are manufactured either of a circularly woven fabric or of a flat fabric. One general fabric material is a circularly woven polypropylene fabric. The bottom of a bulk sack and the lifting eyes are generally formed by means of stitch seams. Such bulk sacks are provided with a plastic inner sack to make the bulk sack tight.

Bulk sacks are nowadays manufactured also of a coated fabric material or of a fabric laminate. In these known bulk sacks, the coating or film surface is on the outer surface of the fabric material, because of which achieving a fully tight bottom by seaming is difficult and uncertain, since achieving a tight bottom in such a way that the fabric surfaces are against each other, does generally not succeed. In these bulk sacks known in prior art, the upper end is formed into a fold bundle, but since it is difficult to connect the the fabric surfaces tightly, a so-called rider band has been used for closing the upper end tightly. Another closing method used for the upper end has been such that the edge of the upper end has been folded double and the outer surfaces of the fabric material have been seamed against each other. The mouth of the bulk sack is also in this embodiment still open, but although the fold closes the upper end, it is not tight. Because of this, the seamed edge is covered with a separate flap for achieving a tight structure.

In the bulk sack solutions known in prior art, in which the film surface is on the outer surface of the fabric material, occurs such a disadvantage that if the film surface is broken, the bulk sack is no longer tight. In such a bulk sack solution, in which the customer her/himself folds the bulk sack after the filling and performs the closing her/himself, such a disadvantage occurs that the filling of the bulk sack is slow and the closing result is uncertain.

In bulk sack solutions, in which a separate inner sack is used, several problems also occur. The filling and closing of the bulk sack is slow and it also easily damages both during the filling and in the subsequent transportation and storage, since some part of the inner sack remains uncovered and is thus especially sensitive to damage.

An object of the invention is to achieve an improvement relative to the bulk sack solutions known at the moment. A more detailed object of the invention is to achieve a bulk sack, in which the

necessary tightness is realized in a reliable manner, whereby the use of the inner sack is not necessary. Another object of the invention is to provide a bulk sack, which makes an easy and fast filling of and lifting of the bulk sack possible in a simple and reliable manner.

The objects of invention are obtained with a flexible container according to claim 1.

In the flexible container according to the invention, the inner surface of the fabric material is coated, a film has been laminated onto the inner surface of the fabric material or a film has been joined onto the inner surface of the fabric material, which film is at least partially fastened to the fabric. The outer surface of the flexible container according to the invention is a basic fabric material, the outer surface of the container is coated or a film has been laminated onto the outer surface of the fabric material of the container.

In the container according to the invention, the filling device is a cuff, which is permanently fastened to the outer or inner surface of the of container. The closing device can also be a closing flap arranged near the filling opening, which flap is partly fixed to the outer surface of the container and which covers the filling opening.

In the container according to the invention, the fold bundle extends downwardly from the upper edge by a distance of at least 10 mm. The fold bundle is then advantageously seamed uniform at least within this distance. However, this is not necessary, but it is in principle sufficient that the fold bundle is seamed at least at its upper part, whereby the remaining fold bundle can be unseamed. The fold bundle can be provided with a hole for a lifting element. The fold bundle can also be provided with a scissors device tightening the traction, or the fold bundle can be folded downwards and fastened with a strap, whereby an opening is formed for the lifting element. The fold bundle can also be tightened with a rope for forming a lifting eye, or a lifting link can be fixed to the fold bundle by making a joint between the lifting link and the fold bundle.

The container according to the invention can also be formed from a double folded fabric material piece or from two fabric material pieces placed on top of each other or from a broad fabric material piece bent into a tube. Bending a broad fabric material piece into a tube in such a way that the film surface of a coated or laminated fabric tube forms the inner surface of the tube, makes the seaming or gluing possible in a very simple manner.

Several important advantages can be reached by means of the flexible container according to the invention. The solution according to the invention makes the achievement of a tight joint possible

merely by the seaming or gluing of the inner surfaces of the fabric material, whereby it is not necessary to ensure the external tightness of the flexible container. The solution according to the invention also decreases the quantity of the fabric material to be used and the manufacturing work, but in spite of this, a better tightness is obtained. Owing to the reliable tightness, the use of an inner sack in the bulk sack according to the invention is unnecessary. The bulk sack can naturally be provided with an inner sack when so desired, if there are some special reasons for using the inner sack, but the use of an inner sack in the solution of the invention is in no way necessary.

In the bulk sack according to the invention, the lifting part is formed into a united fold bundle in connection with the manufacturing of the bulk sack, and a lifting element known per se is joined to the fold bundle. The bulk sack according to the invention is provided with a slot located on the shell, which slot acts as a filling opening. Such a filling opening is closed with a closing device in a manner suitable for invention.

In the bulk sack according to the invention, the fabric material protects the film part acting as an inner surface, and because of this the tightness remains better in case external damage is caused for the bulk sack.

The bulk sack solution according to the invention speeds up the filling of the bulk sack and facilitates as well as ensures a good closing result. When compared to these features, in earlier solutions, in which a separate inner sack is used, both the filling and the closing of the bulk sack is slow. In addition, the inner sack damages easily both during the filling and the subsequent transportation and storage, since some part of the inner sack remains uncovered and is thus very sensitive to damage.

The invention is described in more detail with reference to certain preferable embodiments shown in the figures of the accompanying drawings, to which embodiments the invention is not intended to solely limit.

Fig. 1 shows a certain preferable embodiment of a sack blank of a bulk sack according to the invention.

Fig. 2 shows another preferable embodiment of a sack blank of a bulk sack according to the invention.

Fig. 3 shows a third preferable embodiment of a sack blank of a bulk sack according to the invention.

Fig. 4 shows a certain bulk sack according to the invention. In which the upper end of the bulk sack is formed in a certain preferable manner and correspondingly the triangles of the bottom of the bulk sack in a certain preferable embodiment.

Fig. 5 shows a certain alternative embodiment for fastening the triangles of the bottom of the bulk sack.

Fig. 6 shows another preferable embodiment of the lifting-part solution of the bulk sack according to the invention.

Fig. 7 shows a third preferable embodiment of the lifting-part solution of the bulk sack according to the invention.

Fig. 8 shows a fourth preferable embodiment of the lifting-part solution of the bulk sack according to the invention.

Fig. 9 shows a fifth preferable embodiment of the lifting-part solution of the bulk sack according to the invention.

In the embodiment of Fig. 1, the sack blank of a bulk sack has generally been marked with a reference number 10a. In this embodiment, the sack blank 10a is formed from a doable folded fabric material piece. The bulk sack 10a is thus provided with a shell 11 and a fold on a bottom portion 12. The fabric material according to the invention is comprised of a basic material, whose inner surface is formed of a sealable material. In one embodiment, the inside of the fabric material is coated. In another embodiment a film has been laminated on the inside of the fabric material. In a third embodiment, a film has been joined to the inside of the fabric material, which film is at least partly fastened to the fabric. The outer surface of the fabric material is in a certain embodiment only a basic fabric material. In a third embodiment, a film has been laminated on the outer surface of the fabric material.

In accordance with Fig. 1, a slot is formed on the shell of the bulk sack 10a and preferably in the upper portion of the shell 11 for a filling opening. The edges of shell 11 are seamed with seams 14 and its open upper portion 13 with a seam 14, whereby a completely tight bulk sack blank 10a is formed. The edge seams 14 can also be glue seams, and in addition to seaming, the upper portion can be closed tight also by gluing or with a double-sided tape.

In the embodiment of Fig. 2, bulk sack blank 10b is formed of two separate fabric material pieces placed on top of each other, in which case also an open bottom portion 12 must be seamed or glued with a seam 14. The bottom portion 12 can also be provided with a bottom flap, when needed. The other features of the embodiment shown in Fig. 2 correspond to those shown in Fig. 1.

In the embodiment of Fig. 3, a bulk sack blank 10c is comprised of a sufficiently broad fabric material piece, which is bent into a tube and seamed or glued only at its one edge with a seam 14. The other features of Fig. 3 correspond to those shown in Fig. 2. The broad fabric material

piece can alternatively be bent into a tube so that the edge of the seamed or glued tube is not provided with a vertical seam, but the seams are located in the lower and upper portions of the bent tube. Also in this embodiment, a slot 15 is formed in the manner shown in Fig. 3.

In accordance with Fig. 4, bottom triangles 17 of a bulk sack are folded against the sides of a shell 11 and joined to the sides within the whole range of the bottom triangles 17 or only partially. The bottom triangles 17 can be formed e.g. on a mandrel. When a bulk sack blank 10a, 10b or 10c is drawn on the mandrel, the triangles thus formed can be bent against the sides of the shell 11. The bottom triangles 17 must naturally be performed before the joining of the upper portion.

Around a slot 15 is formed a suitable closing device, such as a cuff or a closing flap 16, which is fastened either to the inner or outer surface of the bulk sack 10 so that a tight joint is formed relative to the surface. Such a joint goes round the entire slot 15. After the filling of the bulk sack 10, the cuff is closed e.g. by seaming, whereby the bulk sack 10 is completely tight. When the closing flap is used, a closing flap is joined to the upper portion or one edge of the slot 15, and when the bulk sack 10 is filled, the slot 15 is closed with the closing flap 16 either by seaming, gluing or with a double-sided tape. A separate flap, such as a tape, can also naturally be used as the closing flap, but a closing flap fixed beforehand is more practical.

In accordance with Fig. 4, the upper portion of the bulk sack is folded, whereby a tight fold bundle 18 is formed. In Fig. 4, the fold bundle 18 is provided with a tight cuff 19. The use of the tight cuff 19 is not necessary, since the surfaces of the fold gaps can be joined to each other so that the fold bundle 18 is uniform and retains its form as such. In Fig. 4, a hole 20 is formed on the fold bundle 18 for a lifting element.

Fig. 5 is otherwise similar to Fig. 4, but in this embodiment the bottom triangles are folded against a bottom 12 of the bulk sack.

In the embodiments of Fig. 4 and 5, the lifting element can be joined to the fold bundle e.g. by threading a lifting link through the hole 20 and the ends of the lifting link are joined together in a suitable manner. E.g. a rope can be used as the lifting link, whose ends are tied together, or a metallic hook, whose ends are joined together.

In the embodiment of Fig. 6, a scissors lifting device 21 has been used, which is fastened to the fold bundle 18. The scissors lifting device tightens up, when it is subjected to a lifting movement, i.e. the scissors lifting device 21 is subjected to traction.

In the embodiment of Fig. 7, the fold bundle 18 is bent into a curve, whereby the fold bundle 18 is

formed of two branches 18a and 18b. The bent fold bundle 18 is fastened with a strap 22, whereby the branches 18a and 18b form an opening 23, through which a lifting element can be threaded. The gap 24 between the branches 18a and 18b can be seamed, glued or furnished with a double-sided tape. The end of the branch 18b of the fold bundle 18 bent downwards can be reinforced with a thickening portion 25. Such a reinforcement can be performed before forming the fold e.g. by placing a film strip across the track. This creates a key effect when lifting the bulk sack 10, whereby traction is formed at the lifting part of the bulk sack 10.

In the embodiment of Fig. 8, a lifting link 26 is fixed to the fold bundle 18. A joint 27 between the lifting link 26 and the fold bundle 18 can be made by gluing, seaming, even by sewing or riveting as long as care is taken of the fact that in those joining modes, in which the joining mode perforates the fold bundle 18, a uniform seam remains also below the holes formed.

In the embodiment of Fig. 9, the fold bundle 18 is formed such that the fold bundle 18 expands upward, preferably conically upward. Below the conical fold bundle 18 is placed a tightening link or a closing device 18 or some other corresponding closing device. Before closing the tightening link 28, a lifting link 26 is threaded in place. When the lifting link is lifted, the tightening link 28 lifts slightly upward on the neck of the bulk sack and is finally locked on the conical part of the upper end of the fold bundle. The closing device can be a one-part locked ring or e.g. a closing device made of two pieces.

Only certain preferred embodiments of the invention have been described above, and it is obvious to those skilled in art that several modifications are possible within the inventive idea defined in the enclosed patent claims.

The invention relates to a flexible container (10) of fabric material for transporting and storing bulk cargo. The container (10) comprises a shell (11) a bottom (12) and a closable filling opening (15). The container (10) can be lifted from its upper end, and the joints forming the container (10) are made by seaming or gluing. At least the inner surface of the container (10) is made of a seamable material, and the shell (11) of the container (10) is provided with a filling opening (15). The lifting part of the container (10) is formed into a united fold bundle (18).

Claims

1. A flexible container (10) of fabric material for transporting and storing bulk cargo, comprising a closed shell (11) and a closable filling opening (15), and the joints (14) forming the container (10) being made by seaming or gluing,

characterized in that

- at least the inner surface of the container (10) is made of a seamable material joined at its edges to form said joints (14), said filling opening (15) being furnished with a closing device (16) and arranged in a wall of said shell, and the upper, lifting part of the container (10) being formed into a united fold bundle (18).
2. A container according to Claim 1, **characterized** in that the inner surface of the fabric material of the container (10) is coated.
 3. A container according to Claim 1, **characterized** in that a film has been laminated on the inner surface of the fabric material of the container (10).
 4. A container according to Claim 1, **characterized** in that a film has been joined on the inner surface of the fabric material of the container (10), which film is at least partly fixed to the fabric.
 5. A container according to any of the Claims 1-4, **characterized** in that the outer surface of the container is a basic fabric material.
 6. A container according to any of the Claims 1-4, **characterized** in that the outer surface of the fabric material of the container (10) is coated.
 7. A container according to any of the Claims 1-4, **characterized** in that a film has been laminated on the outer surface of the fabric material of the container (10).
 8. A container according to any of the Claims 1-7, **characterized** in that the closing device (16) is a cuff surrounding the filling opening, which is permanently joined to the outer or inner surface of the container (10).
 9. A container according to any of the Claims 1-7, **characterized** in that the closing device (16) is a closing flap placed near the filling opening (15), which flap is partially fixed to the outer surface of the container (10) and covers the filling opening (15).
 10. A container according to any of the Claims 1-9, **characterized** in that the fold bundle (18) extends from its upper edge downward by a distance of at least 10 mm.
 11. A container according to any of the Claims 1-10, **characterized** in that the fold bundle (18) is provided with a hole (20) for the lifting element.
 12. A container according to any of the Claims 1-10, **characterized** in that a scissors device tightening via traction (21) is integrated with the fold bundle (18).
 13. A container according to any of the Claims 1-10, **characterized** in that the fold bundle (18) is folded downward and fastened with a strap (22), whereby an opening (23) is formed for the lifting element.
 14. A container according to any of the Claims 1-10, **characterized** in that the fold bundle (18) is tightened with a rope for forming a lifting eye.
 15. A container according to any of the Claims 1-10, **characterized** in that a lifting link (26) is joined to the fold bundle (18).
 16. A container according to any of the Claims 1-10, **characterized** in that the fold bundle (18) is formed into an upwardly expanding fold bundle and that the lifting link (26) is locked into the fold bundle (18) by means of a closing device (28) fitted below its expanding part.
 17. A container according to any of the Claims 1-16, **characterized** in that the container (10) is formed of a double folded fabric material piece.
 18. A container according to any of the Claims 1-16, **characterized** in that the container (10) is formed of two fabric material pieces placed on top of each other.
 19. A container according to any of the Claims 1-16, **characterized** in that the container is formed of a broad fabric material piece, which is bent into a tube.

Patentansprüche

1. Flexibler Behälter (10) aus Material aus textilen Flächengebilde zum Transportieren und Speichern von Schüttgut, der eine geschlossene Außenhaut (11) und eine schließbare Füllöffnung (15) aufweist, wobei die Verbindungen (14), die den Behälter (10) bilden, durch Zusammennähen oder Leimen gefertigt sind, dadurch gekennzeichnet, daß
zumindest die Innenfläche des Behälters (10) aus einem zusammennähbaren Material gefertigt ist, das an seinen Kanten verbunden ist, um die Verbindungen (14) auszubilden, wo-

- bei die Füllöffnung (15) mit einer Schließvorrichtung (16) ausgestattet und in einer Wand der Außenhaut angeordnet ist und der obere Hebeteil des Behälters (10) zu einem vereinigten Faltbund (18) ausgebildet ist.
2. Behälter nach Anspruch 1, dadurch gekennzeichnet, daß die Innenfläche des Materials aus textilem Flächengebilde des Behälters (10) beschichtet ist.
 3. Behälter nach Anspruch 1, dadurch gekennzeichnet, daß ein Film auf die Innenfläche des Materials aus textilem Flächengebilde des Behälters (10) aufgebracht wurde.
 4. Behälter nach Anspruch 1, dadurch gekennzeichnet, daß ein Film mit der Innenfläche des Materials aus textilem Flächengebilde des Behälters (10) verbunden wurde, wobei der Film zumindest teilweise am textilen Flächengebilde befestigt ist.
 5. Behälter nach einem der Ansprüche 1 bis 4, dadurch gekennzeichnet, daß die Außenfläche des Behälters aus einem Grundmaterial aus textilem Flächengebilde ist.
 6. Behälter nach einem der Ansprüche 1 bis 4, dadurch gekennzeichnet, daß die Außenfläche des Materials aus textilem Flächengebilde des Behälters (10) beschichtet ist.
 7. Behälter nach einem der Ansprüche 1 bis 4, dadurch gekennzeichnet, daß ein Film auf die Außenfläche des Materials aus textilem Flächengebilde des Behälters (10) aufgebracht wurde.
 8. Behälter nach einem der Ansprüche 1 bis 7, dadurch gekennzeichnet, daß die Schließvorrichtung (16) eine die Füllöffnung umgebende Manschette ist, die mit der Außen- oder Innenfläche des Behälters (10) dauerhaft verbunden ist.
 9. Behälter nach einem der Ansprüche 1 bis 7, dadurch gekennzeichnet, daß die Schließvorrichtung (16) eine Schließklappe ist, die nahe der Füllöffnung (15) positioniert ist, wobei die Klappe an der Außenfläche des Behälters (10) teilweise befestigt ist und die Füllöffnung (15) bedeckt.
 10. Behälter nach einem der Ansprüche 1 bis 9, dadurch gekennzeichnet, daß sich das Faltbund (18) von seiner oberen Kante um einen Abstand von zumindest 10mm nach unten erstreckt.
 11. Behälter nach einem der Ansprüche 1 bis 10, dadurch gekennzeichnet, daß das Faltbund (18) mit einem Loch (20) für das Hebeelement versehen ist.
 12. Behälter nach einem der Ansprüche 1 bis 10, dadurch gekennzeichnet, daß eine Scherenvorrichtung (21), die über Zugkraft festklammert, mit dem Faltbund (18) vereinigt ist.
 13. Behälter nach einem der Ansprüche 1 bis 10, dadurch gekennzeichnet, daß das Faltbund (18) nach unten gefaltet und mit einer Schelle (22) befestigt ist, wodurch eine Öffnung (23) für das Hebeelement ausgebildet ist.
 14. Behälter nach einem der Ansprüche 1 bis 10, dadurch gekennzeichnet, daß das Faltbund (18) mit einem Seil zum Formen eines Hebeauges befestigt ist.
 15. Behälter nach einem der Ansprüche 1 bis 10, dadurch gekennzeichnet, daß eine Hebeverbindung (26) mit dem Faltbund (18) verbunden ist.
 16. Behälter nach einem der Ansprüche 1 bis 10, dadurch gekennzeichnet, daß das Faltbund (18) zu einem sich nach oben erweiternden Faltbund ausgebildet ist und daß die Hebeverbindung (26) im Faltbund (18) mittels einer Schließvorrichtung (28) festgeklemmt ist, die unterhalb seines Erweiterungsteils gepaßt ist.
 17. Behälter nach einem der Ansprüche 1 bis 16, dadurch gekennzeichnet, daß der Behälter (10) aus einem doppelt gefalteten Materialstück aus textilem Flächengebilde ausgebildet ist.
 18. Behälter nach einem der Ansprüche 1 bis 16, dadurch gekennzeichnet, daß der Behälter (10) aus zwei Materialstücken aus textilem Flächengebilde, die übereinander positioniert sind, ausgebildet ist.
 19. Behälter nach einem der Ansprüche 1 bis 16, dadurch gekennzeichnet, daß der Behälter aus einem breiten Materialstück aus textilem Flächengebilde ausgebildet ist, das zu einem Rohr gekrümmt ist.

Revendications

1. Récipient en matière souple (10) en tissu pour le transport et le stockage de matériaux en vrac, comprenant une enveloppe fermée (11),

- et un orifice de remplissage obturable (15) et les articulations (14) formant le récipient (10) sont réalisées par couture ou collage, caractérisé en ce qu'
au moins la surface interne du récipient (10) est réalisée en un matériau pouvant être cousu, l'orifice de remplissage (15) étant muni d'un dispositif d'ouverture (16) et ménagé dans une paroi de l'enveloppe la partie de levage supérieure du récipient étant constituée par un faisceau plié assemblé (18).
2. Récipient selon la revendication 1, caractérisé en ce que la surface interne du tissu du récipient (10) comporte un revêtement.
 3. Récipient selon la revendication 1, caractérisé en ce qu'une pellicule a été stratifiée à la surface interne du tissu du récipient (10).
 4. Récipient selon la revendication 1, caractérisé en ce qu'une pellicule a été appliquée sur la surface interne du tissu du récipient (10), laquelle pellicule est au moins partiellement fixée sur le tissu.
 5. Récipient selon l'une quelconque des revendications 1-4, caractérisé en ce que la surface extérieure du récipient est constitué d'un tissu nature.
 6. Récipient selon l'une quelconque des revendications 1-4, caractérisé en ce que la surface extérieure du tissu du récipient (10) est munie d'un revêtement.
 7. Récipient selon l'une quelconque des revendications 1-4, caractérisé en qu'une pellicule a été appliquée sur la surface extérieure du tissu du récipient (10).
 8. Récipient selon l'une quelconque des revendications 1-7, caractérisé en ce que le dispositif de fermeture (10) est un manchon entourant l'orifice de remplissage assemblé en permanence sur la surface externe ou interne du récipient (10).
 9. Récipient selon l'une quelconque des revendications 1-7, caractérisé en ce que le dispositif de fermeture (16) est un volet de fermeture placé à proximité de l'orifice de remplissage (15) lequel volet est partiellement fixé sur la surface externe du récipient (10) et recouvre l'orifice de remplissage (15).
 10. Récipient selon l'une quelconque des revendications 1-9, caractérisé en ce que le faisceau plié (18) s'étend du bord supérieur vers le bas sur une distance d'au moins 10 mm.
 11. Récipient selon l'une quelconque des revendications 1-10, caractérisé en ce que le faisceau plié (18) est muni d'un orifice (20) pour l'élément de levage.
 12. Récipient selon l'une quelconque des revendications 1-10, caractérisé en ce qu'un dispositif de type ciseaux se resserrant sous l'effet de la traction (21) est intégré avec le faisceau plié (18).
 13. Récipient selon d'une quelconque des revendications 1-10, caractérisé en ce que le faisceau plié (18) est replié vers le bas et fixé par une sangle (22), une ouverture (23) étant ainsi formée pour l'élément de levage.
 14. Récipient selon l'une quelconque des revendications 1-10, caractérisé en ce que le faisceau plié (18) est serré à l'aide d'une corde pour former un oeillet de levage.
 15. Récipient selon l'une quelconque des revendications 1-10, caractérisé en ce qu'une articulation de levage (26) est relié au faisceau plié (18).
 16. Récipient selon l'une quelconque des revendications 1-10, caractérisé en ce que le faisceau plié (18) est formé en un faisceau plié s'étendant vers le haut et en ce que l'articulation de levage (26) est bloquée dans le faisceau plié (18) au moyen d'un dispositif de fermeture (28) fixé au dessous de sa partie d'expansion.
 17. Récipient selon l'une quelconque des revendications 1-16, caractérisé en ce que le récipient (10) est constitué d'une double pièce de tissu plié.
 18. Récipient selon l'une quelconque des revendications 1-16, caractérisé en ce que le récipient (10) est constitué par deux pièces de tissu juxtaposées.
 19. Récipient selon l'une quelconque des revendications 1-16, caractérisé en ce que le récipient est constitué d'une large pièce de tissu qui est pliée pour former un tube.

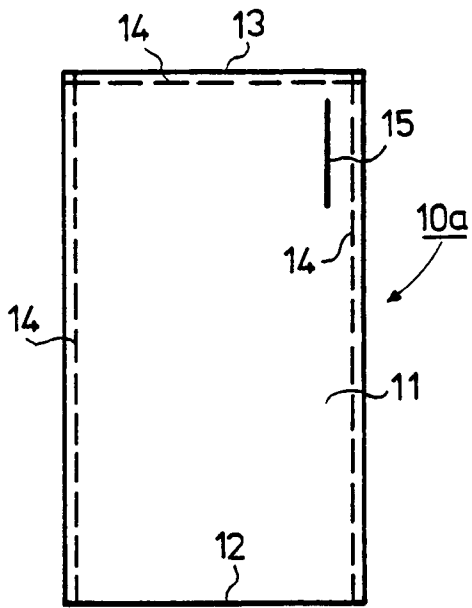

FIG. 1

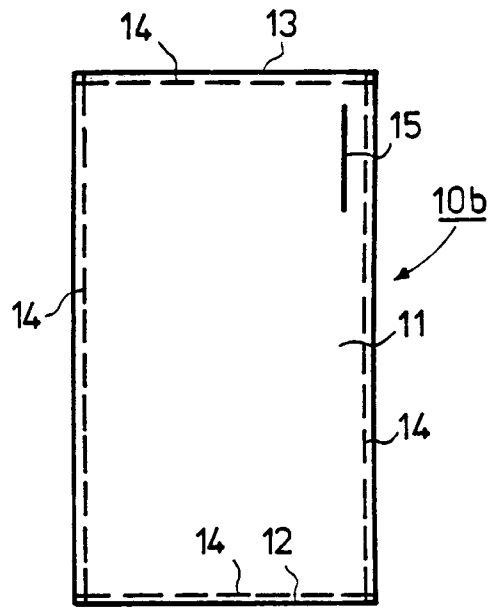

FIG. 2

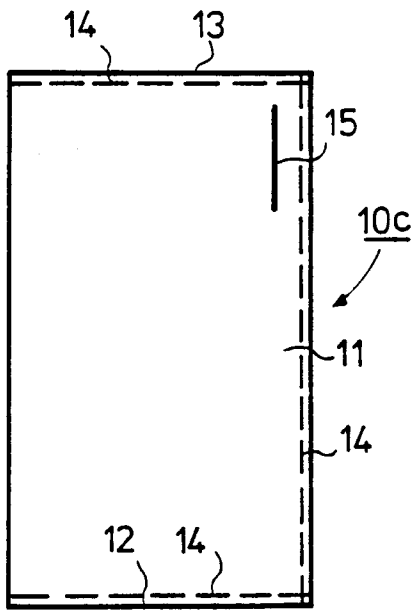

FIG. 3

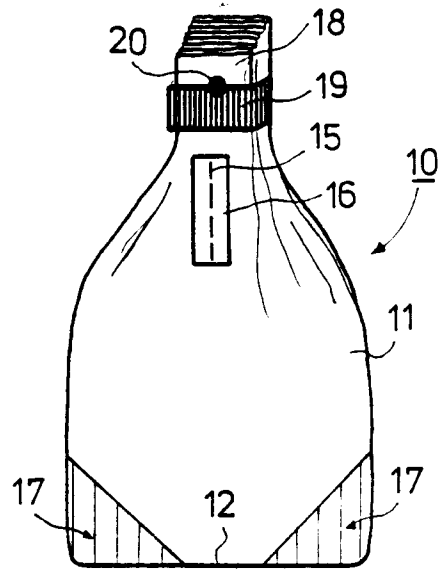

FIG. 4

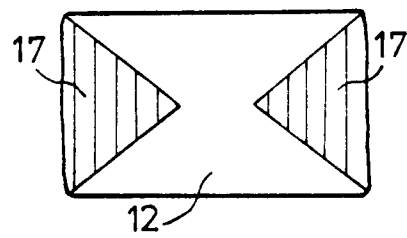

FIG. 5

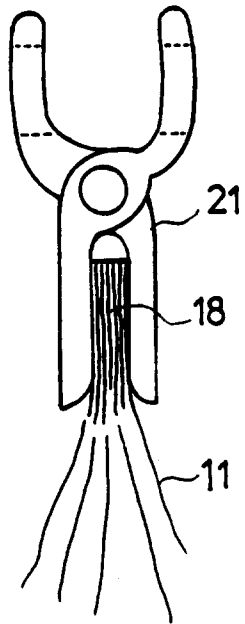

FIG. 6

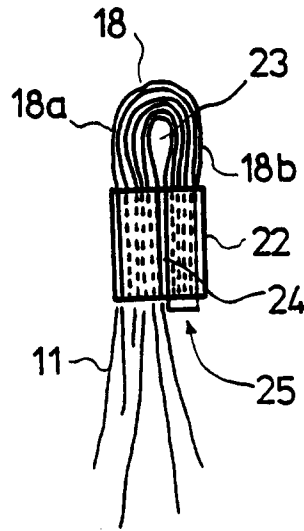

FIG. 7

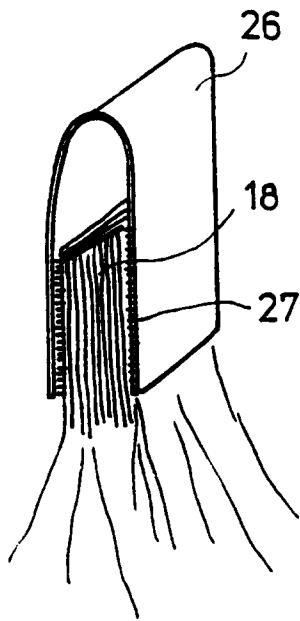

FIG. 8

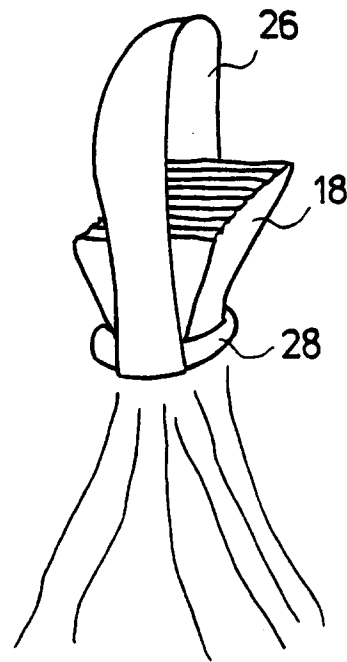

FIG. 9