

(19)
(12)

(KR)
(A)

(51) 。 Int. Cl. ⁷
H01R 13/436

(11)
(43)

2002 - 0003662
2002 01 15

(21) 10 - 2000 - 0034712
(22) 2000 06 23

(71) ()

705 - 15 702

(72) 377 - 3 가 401

(74)
:

(54)

가	가	가	가	가	1
			.		
			,		2
(2200) ,				2	가
		2		(2210, 2220)	,
		(2211, 2221) 가	,	가	(2300)
		2		가	,

5

, , , , , , ,

1					,
2	1				,
3	1				,
4	1				,
5	1			가	,
6	1	10		가	,
7	4				,
8	7				,
9	7				,
10	7				,
11	7				,
12	7				,
13	1				,
13a	2				,
13b	2			1	,
13c	2			2	,
14	13				,
14a	13b	1			,
14b	13c	2			,
15	13				,
15a	13b	1			,
15b	13c	2			,
16	13				,
16a	13b	1			,

16b 13c 2 ,

17 13 가 ,

17a 13a 가 ,

18 17 ,

18a 17a ,

19 가 ,

20 가 ,

21 20 가 ,

22 20 가 ,

23 20 가 ,

24 20 가 ,

25 20 가 ,

26 10 가 가 ,

27 26 3 .

가 , 가 ,
 가 가

가 ,
 가 .

가 ,
 가 , 가 ,

가 , 가 , 가 , 가 ,

가

가

가

가

가 가

가

가

가 가

가

1

2

2
가

2

가 (2300)

2

가

가

가

가

가

가

, 1

가

2

2
가

2
가

2

가
가

가

가

가가

2

2

가

1

2

가

가

1

3

(1000)

10

, 2

10

(1010

1100)

2

10

(1010

1100)

(1200)

(1300)

(1201

1210 1301

1310)가

(1010

1100)

2

(1411, 1412, 1413, 1414)

1

(1401)

4

가

4
00)

(1010 1100)

가

, 5

(10

(2000)가

가

, 6

(1000) 10

(2000)가

가

7

4

(2000)

(2100)

가

, 8

가

, 9

가

, 10

가

, 11

가

, 12

가

(2100) , (2000) (2
000) . 7 , (2100) , , 12 (2100)
가 (2101, 2102)) , , 7
(2100) , , 8 (2100)
가 가 가 (2111, 2112) . 7 12
(2100) (2101, 2102) 가 (2111, 2112) 2
2 가 .

13 1 가 , 14 가
, 15 가 , 16 가 .

(2200)
, 1 1 (2210) , 2 2
(2220) 가 , 1 2 (2230)
. (2210, 2220, 2230) (2211, 2221, 2231)
(2211, 2221, 2231) V . V (2
211, 2221, 2231) 가 . , (2211, 2221, 2
231) , V 가 (2211, 2221, 22
31) 가 , (2211, 2221, 2231)
. , (2211, 2221, 2231) 가 .

17 13 16 (2200)가 (2100)
, 18 .

17 , (2100) 4 (2130, 2140, 2150, 2160) 가 , 2
(2200) 4 (2130, 2140, 2150, 2160) .

2 가 , (1010 1100) (2000) , (1010 1100)
(1401) (2000) (2100) 4 (2130, 2140, 2150, 2160)
2 (2101, 2102) (2107) ,
(1401) (2000) (2100) (2130) (2150) ,
(2000)가 (1010 1100) . , 4 (1411,
1412, 1413, 1414) (2000) (2100) 4 (2130, 2140, 2150, 2160)
(2140) (2200) (2160) (2200)
(2000)가 (1010 1100) .

, (1000) (1201 1210 1301 1310) (2000)
(2100) (2130) (2150) (2111, 2121) . (1201
1210 1301 1310) ,

, (2000) (2100) (2140) (2160) (2141)
, (2141) (2000)가 (1000) (1000)

(1501, 1601) . (2141, 1501, 1601) (2000) (2100)가 ((1000) (1201 1210 1301 1310) (2111, 2121) (1701) . 19 (1000) (2000)가 (1701) 가 .

18 , (2100) (2101, 2102) (2200) (2100) 가 (2111, 2112) 1 (2210) 2 (2220)가 , (2230) (2100) (2141) (2143, 2144)

20 (2200) (2210, 2220) (2211, 2221) 가 가 , 21 가 , 22 가 , 23 가 , 24 가 , 25 가 .

20 24 , 가 (2300) , (2100) 가 (2111, 2112) (2310) (2310) (2310) (2310) (2310)가 (2100) 가 (2111, 2112) (2100) (2130) (2150) (2131, 2132, 2151, 2152) (2310)가 (2310)가 (2330, 2340)가 (2100) 가 (2111, 2112) 2 (2330, 2340) 1 (2320) 0)가 1 (2320) , 1 (2330, 2340) (2310) 2 (2350) (2350) 1, 2152) , (2330, 2340)가 (2310) (2100) 가 (2111, 2112) (2310)가 (2100) 가 (2111, 2112) . 1 (2320) 2 (2350) (2310)가 (2100) 가 (2321, 2351)가 .

가 (2300) (2310) 2 (2311, 2312) , (2313, 2314) (2200) 1 (2210) 2 (2220)가 2 (2300) (2100) 가 (2300) 가 (2111) 가 (2300) 가 (2112) 가 (2300) 가 .

00) 2 가 (2300)가 (2100) 가 (2111) , (2101, 2102) (2200) 1 (2210)가 2 (2313, 2314) , , (2311, 2312) 1 (2210) (2211) 가 , , 가 (2300)가 (2100) 가 (2112) , (2100) 2 (2101, 2102) , , (2200) 2 (2220)가 2 (2313, 2314) , , (2311, 2312) 2 (2220) (2221) 가 .

26 (1000) 10 (2000)가 1 3
 (1010 1030) (2000) 가 (2300) 가 7
 , 4 6 (1040 1060) (2000) 가 , 10 (1
 9 (1070 1090) (2000) 가 , 10 (1
 110) (2000) 가 .

, 7 9 (1070 1090) (2000) (1000) (13
 00) (1330 1350) (2000) . 1 3
 (1010 1030) 가 (2300) (2310) 2
 (2311, 2312) (2210, 2220) (2211, 2221)
 (2310)
 2 (2311, 2312) 가 (2000) 1 3 (1010
 1030) (2310) 1 (2320)
 , (2311, 2312) 가 (2210, 2220) (2211, 2221)
 (2211, 2221) 가
 (2000) 가 . , 7 9 (1070 1090)
 (2310) , 10 (1110) (2000)
 (2311, 2312) 1 (23
 20) (2210, 2220) (2211, 2221) , ,
 , , ,
 가 N:1 1:N 가 , ,
 가 (2111,2112) (2310) (2311,2312)

, , 가 , 가 , 가
 (2300) 가 (2111, 2112) (2310) , 가 (2111, 2
 112) 가 (2310) , , (2210, 2220)
 , 1 (2320)
 (2211, 2221) .

가 (2111, 2112) (2310)
 , 가 (2300) 1 (2320) 2 (2350) ()
 . 가 (2300)가 , (2100) (2000)
 가 (2300) .

, 13a 13c 2 가 , 14a
 14b 가 , 15a 15b 가 , 16a 16b
 가 .

13a , 2 (2200) 13b 1 (2200A) 13c
 2 (2200B) 2 . 2 (2200B) 1
 1 (2210) , 1 (2250) 가 , 1 (2
 200A) 2 2 (2220) 가 , 1 2

2 (2240) . (2230) , 2 1 (2250)

17a 13a 16b 2 (2200)가 (2100)
 , 18a .

17a 18a , 1 (2200A) 2 (2200B) 1 (2250) 2 (2240)가
 , (2100) . 1 (2250) 2 (2240)가 (2100)가
 2100) ()가 .

27 (1000) 3 10 (3000)가 1
 3 (1010 1030) (3000) 가 (3300)
 가 , 4 6 (1040 1060) (3000) 가 (3000) 가 , 1
 , 7 9 (1070 1090) (3000) 가 .
 0 (1110) (3000)

10 (1100) (3000) , 가 (3300)
 (3310) . 1
 (3311, 3312) , 2 (3313,
 3314) .

(57)

1.

1

가 ,

가 , 가 (2300) , 2

가

2.

1 ,

2 가 ,

가 , 2 ,

가 , 2 가 ,

가

3.

2 ,

가가 가 ,

4.

2 ,

2 2

5.

2 4 ,

가 ,

,

, 가¹ 2

6.

2 4 ,

가

7.

1 3 ,

가 1 1 2 , 1 2 가

1

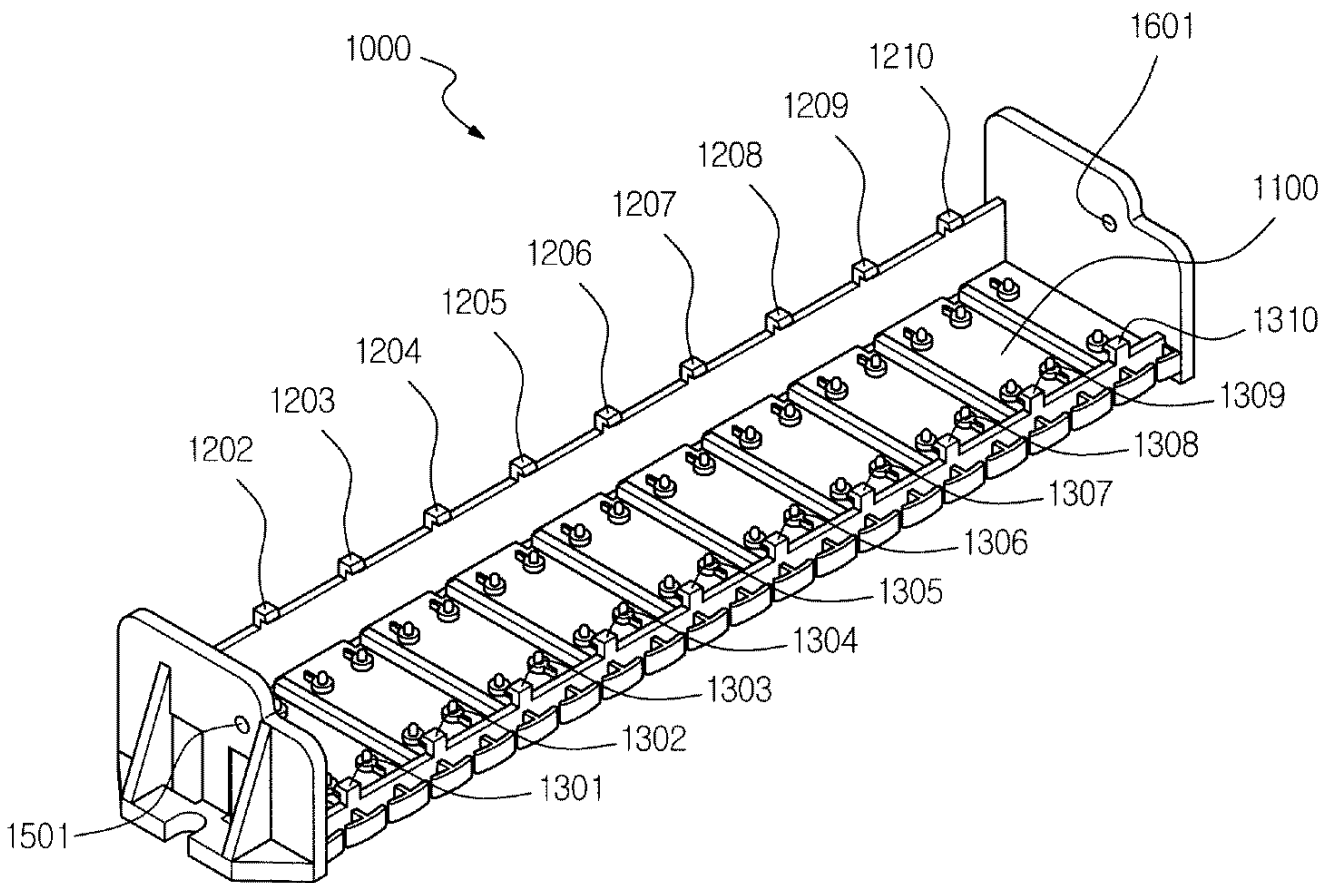

2

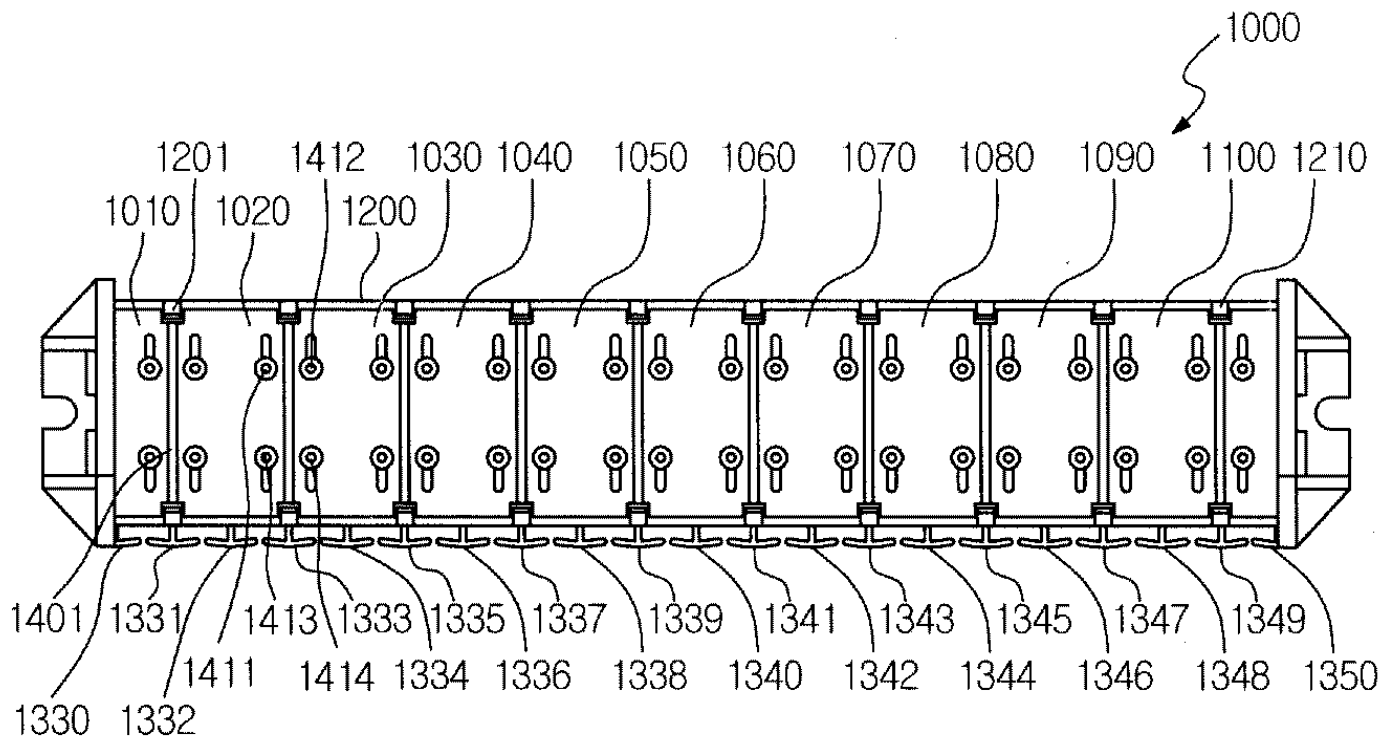

3

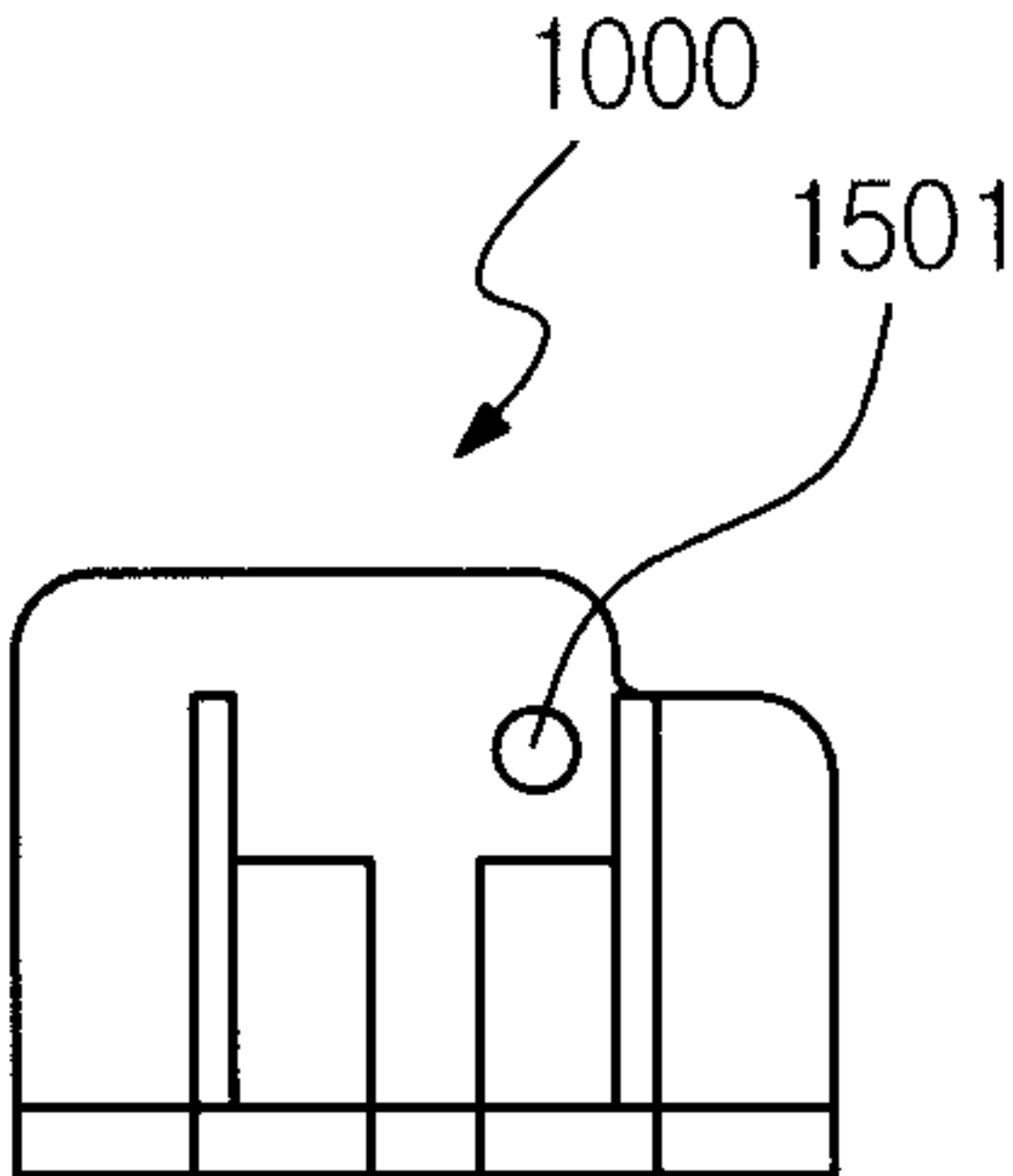

4

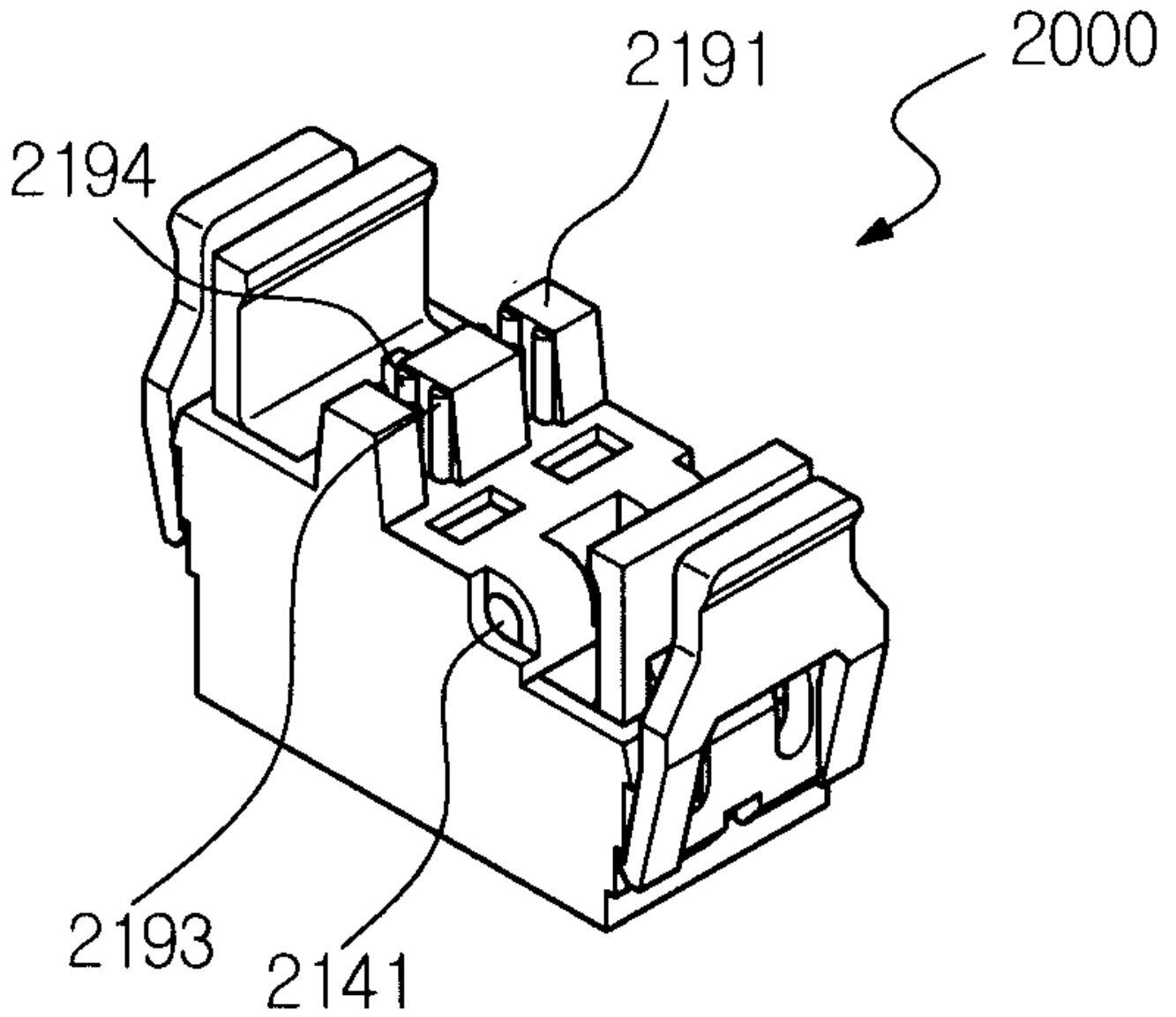

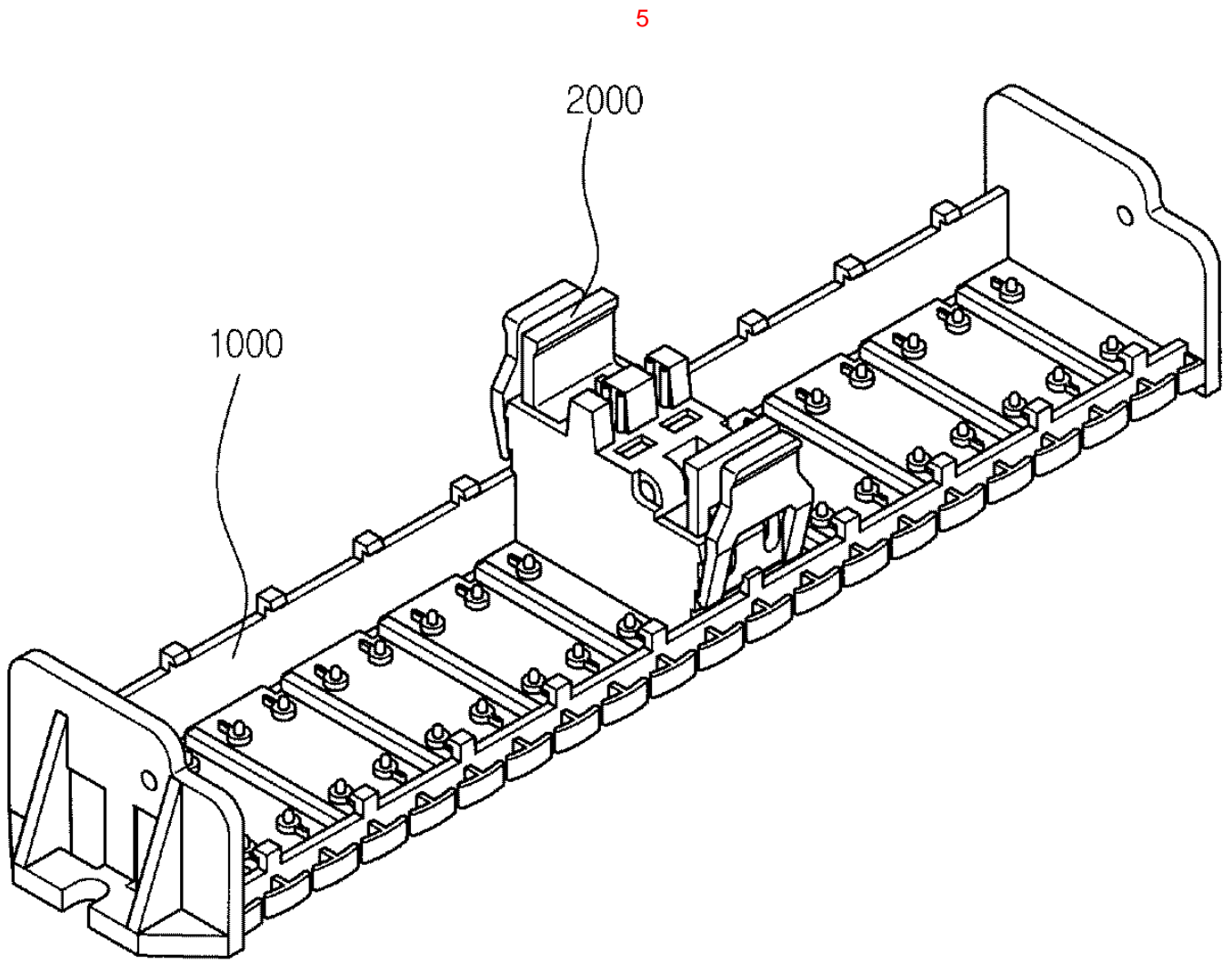

6

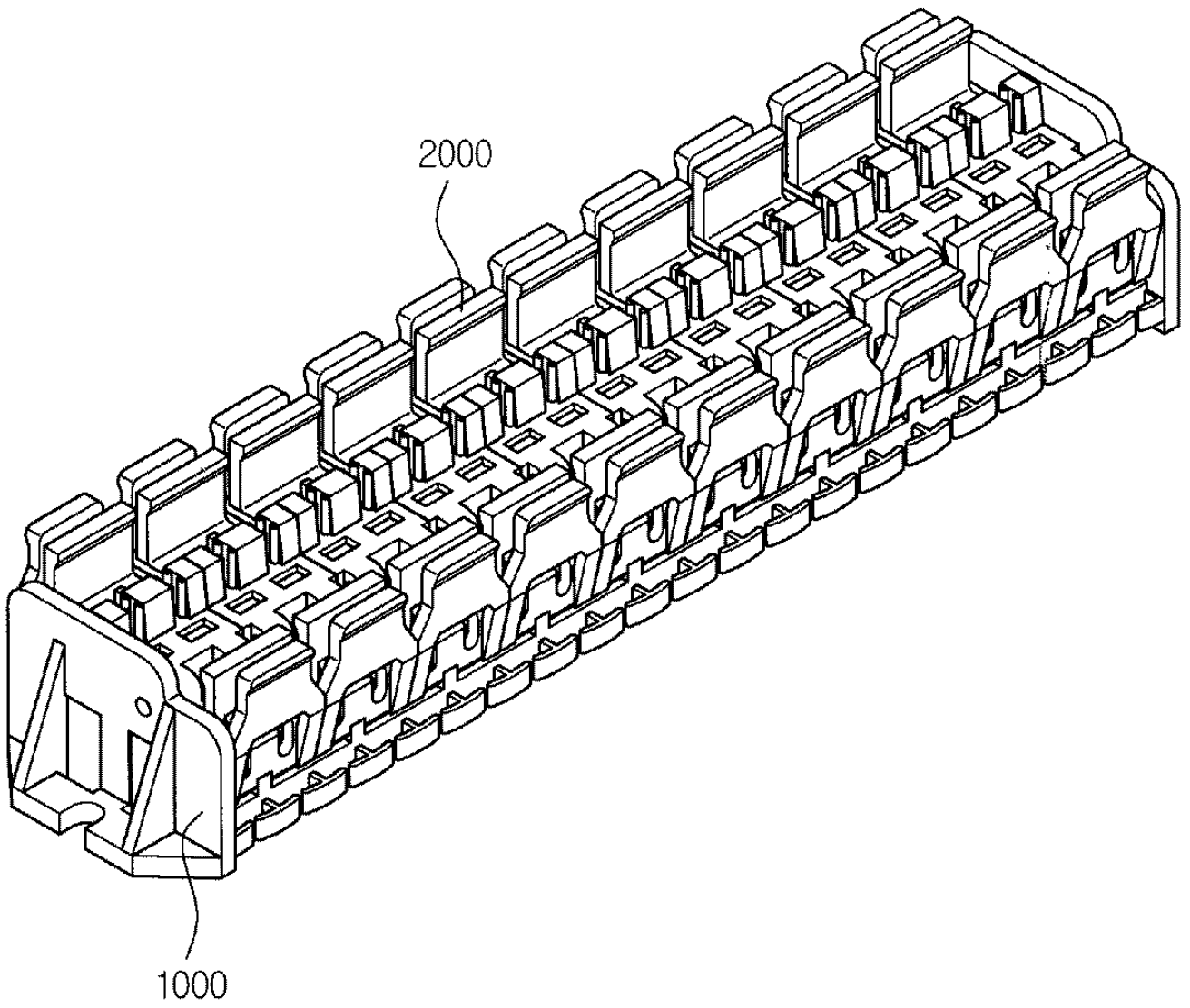

7

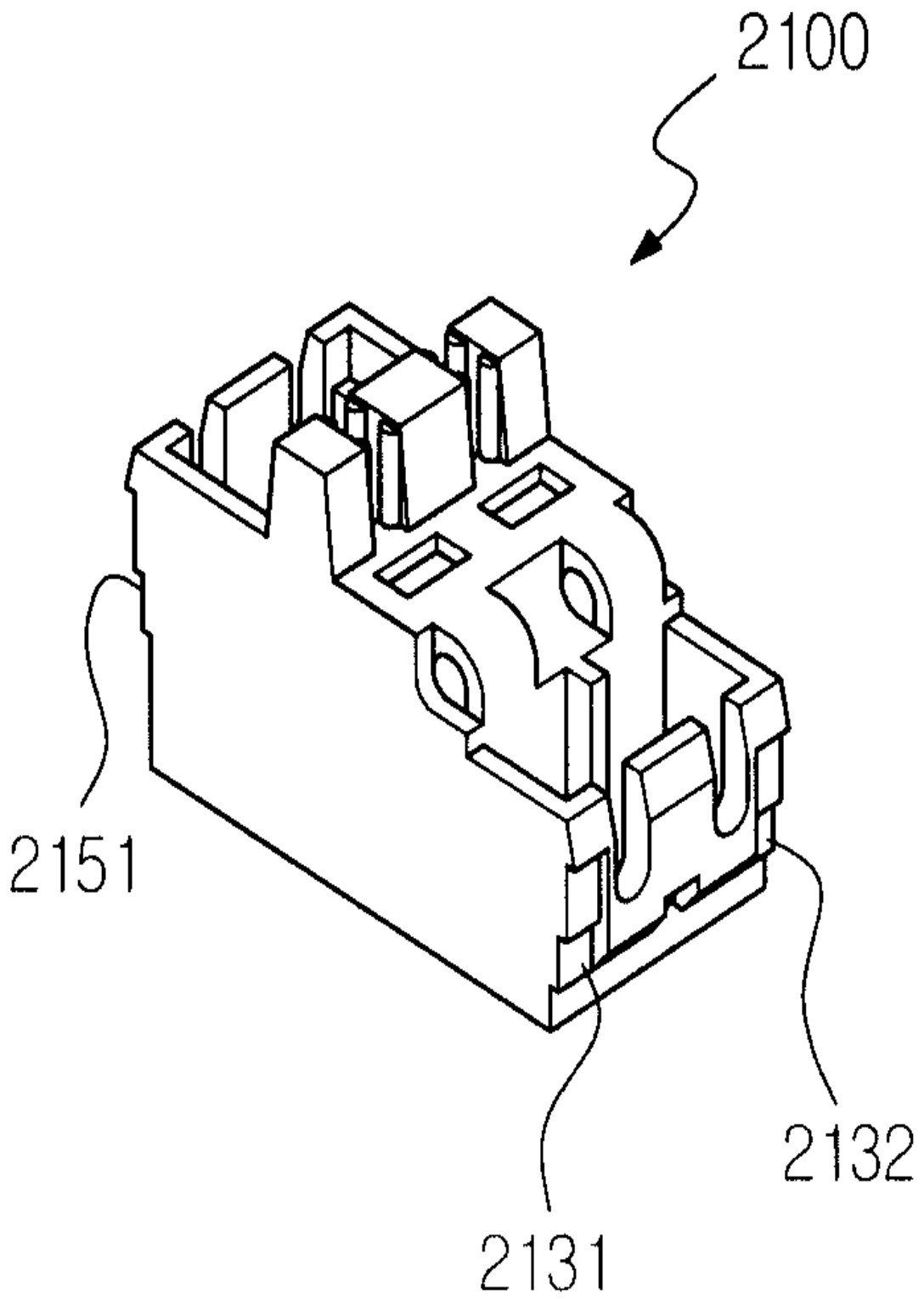

8

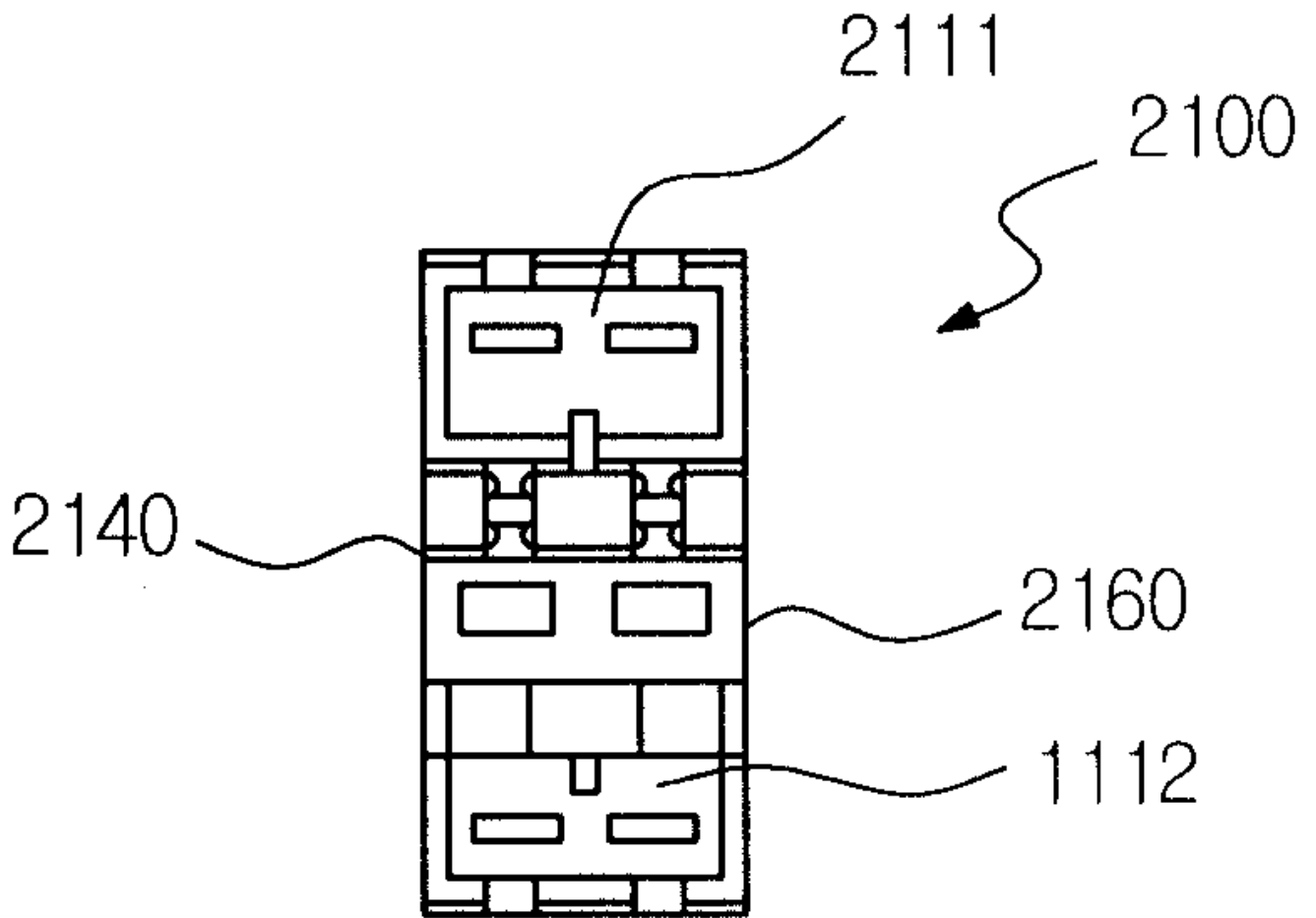

9

2100

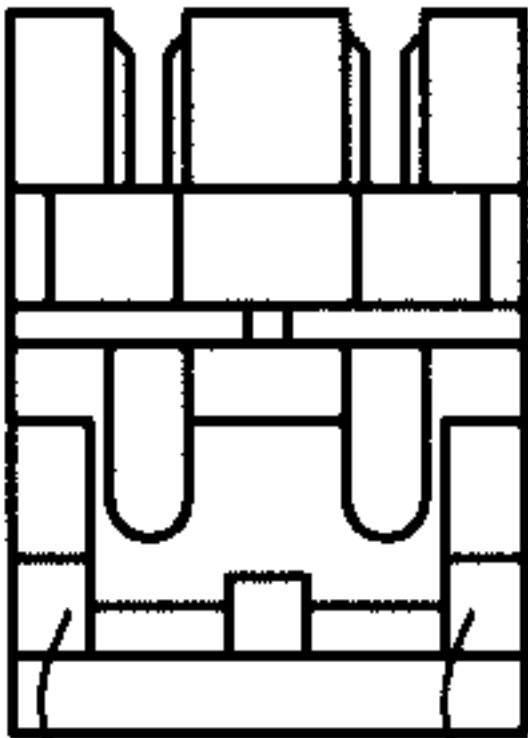

2131

2132

10

2100

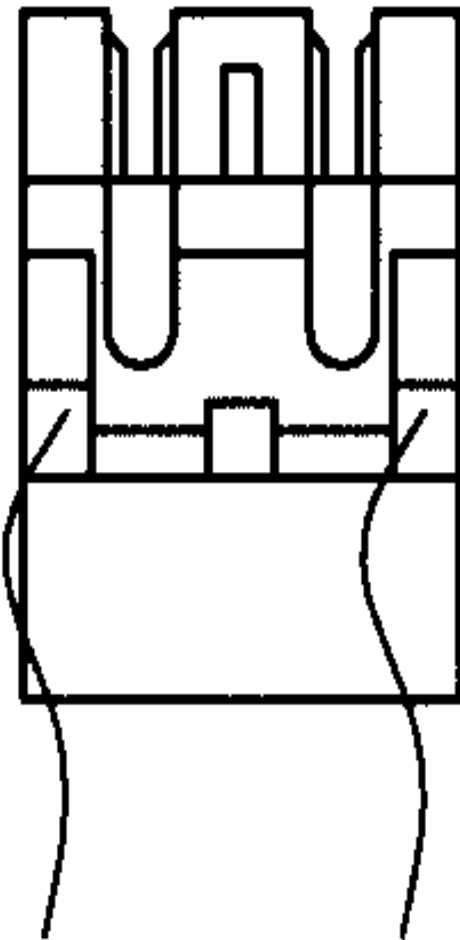

2151

2152

11

2100

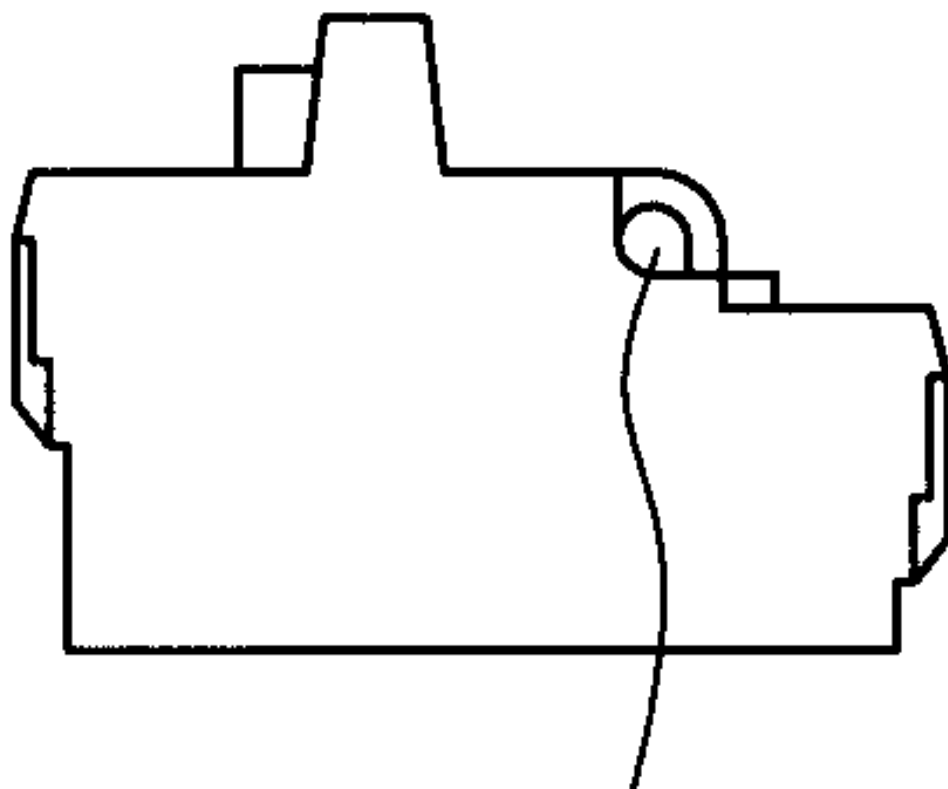

2141

12

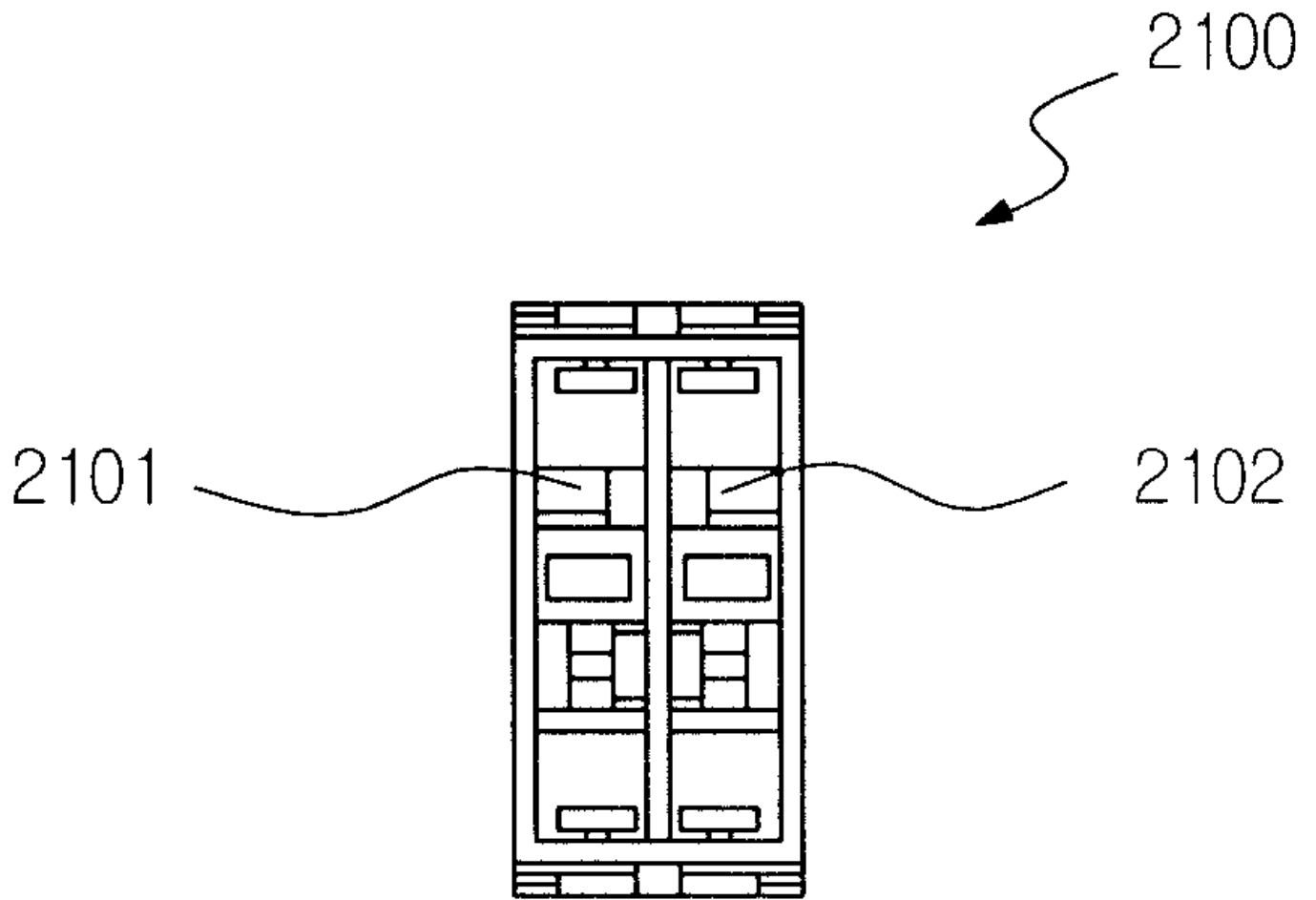

13

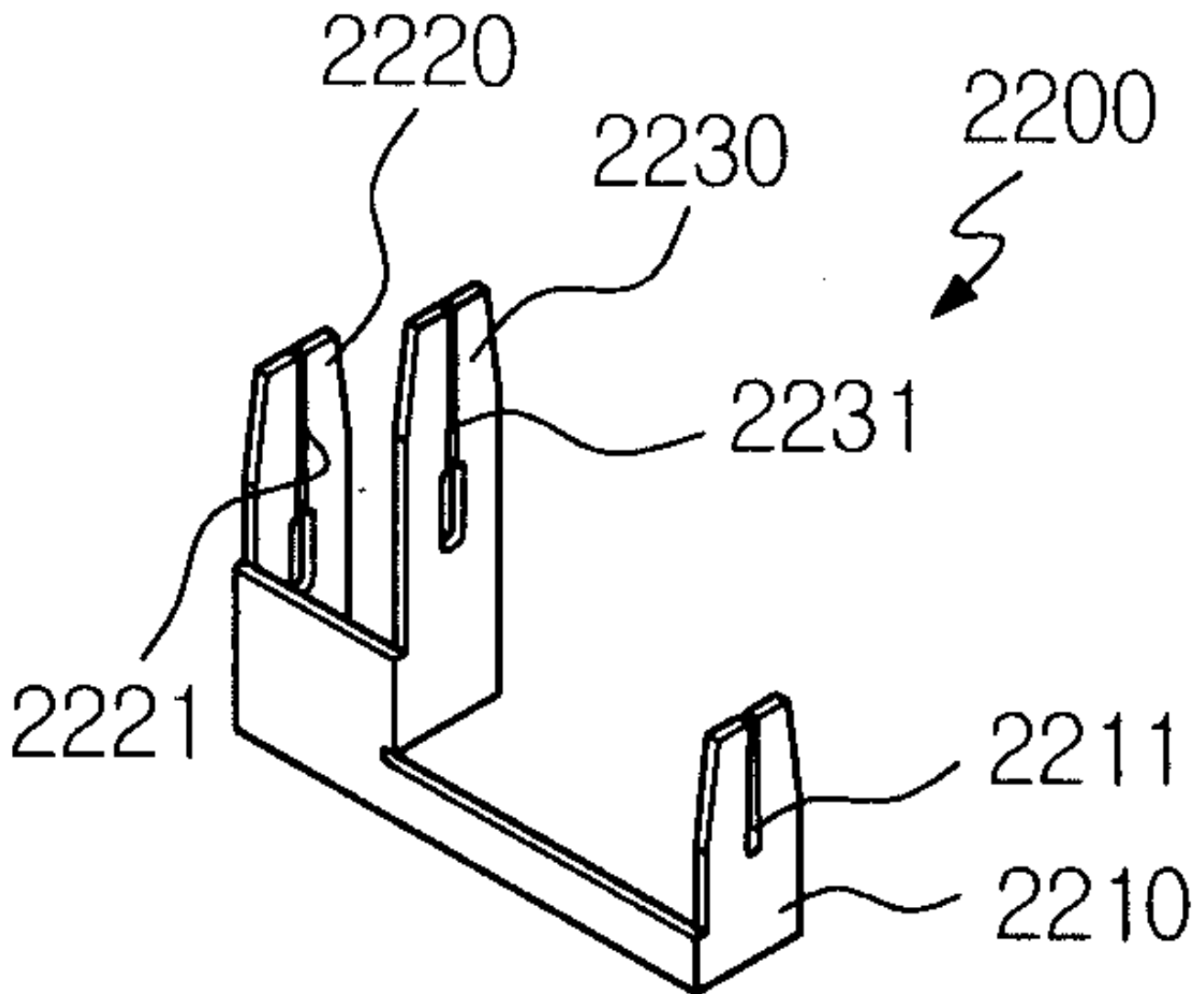

13a

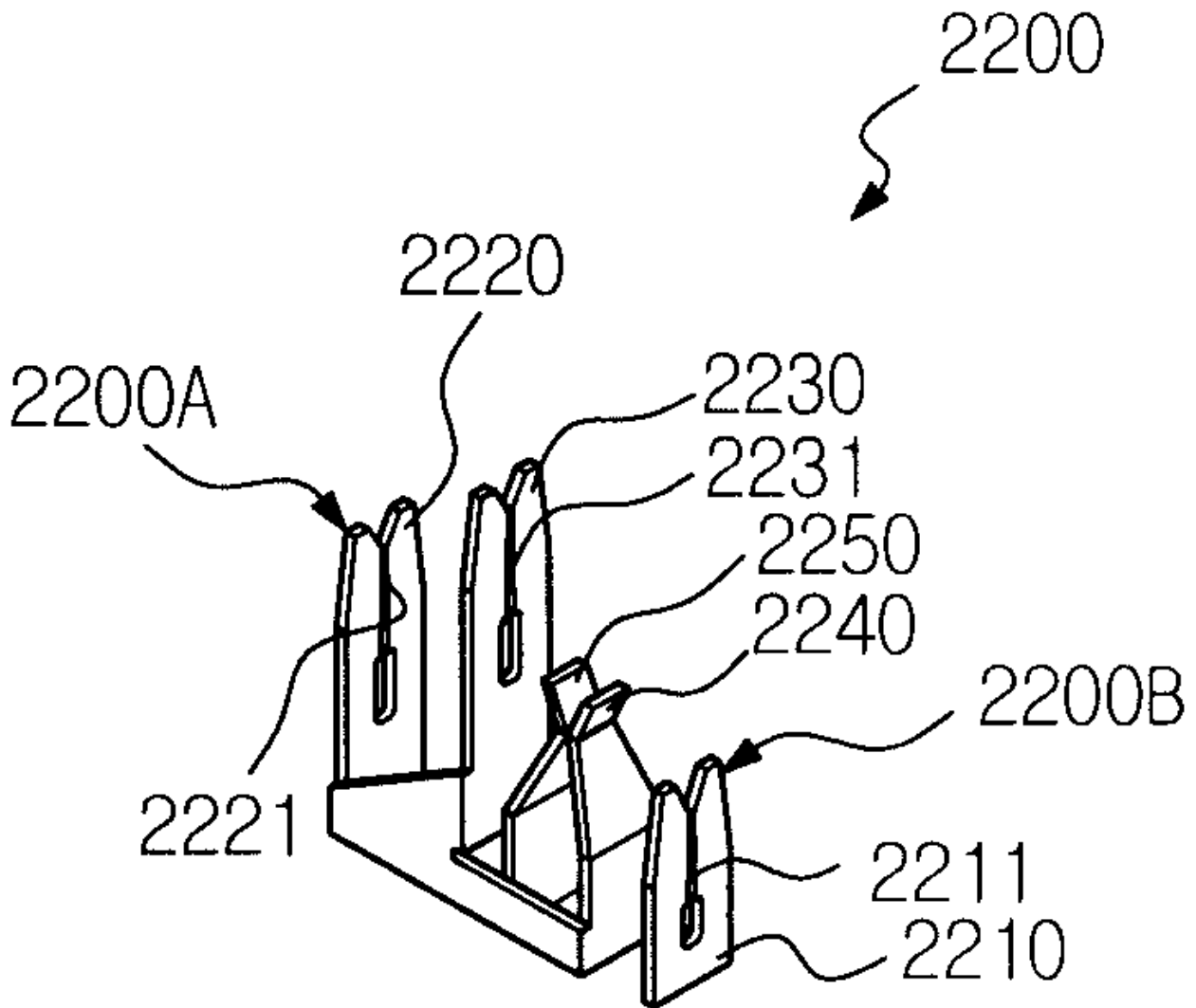

13b

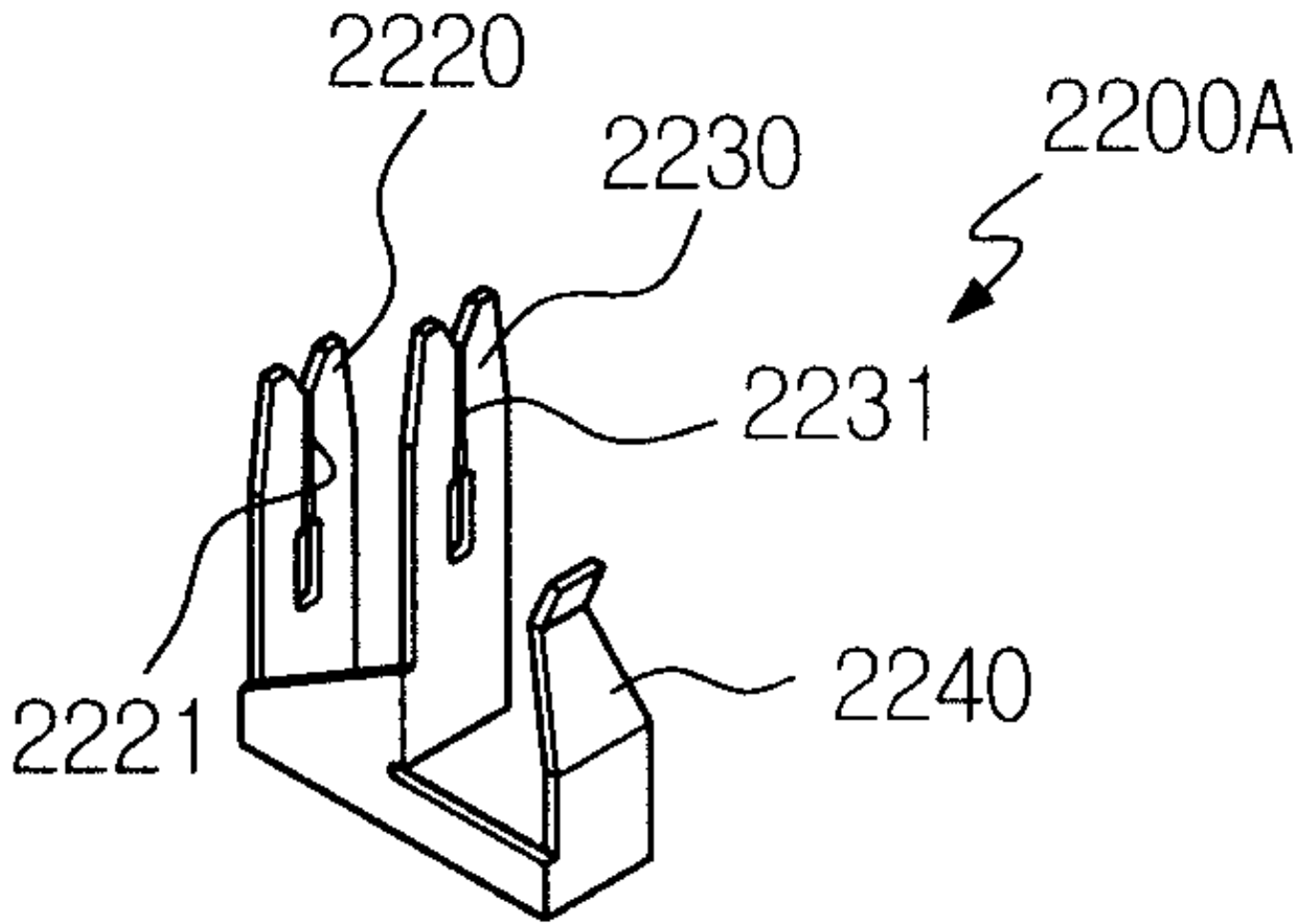

13c

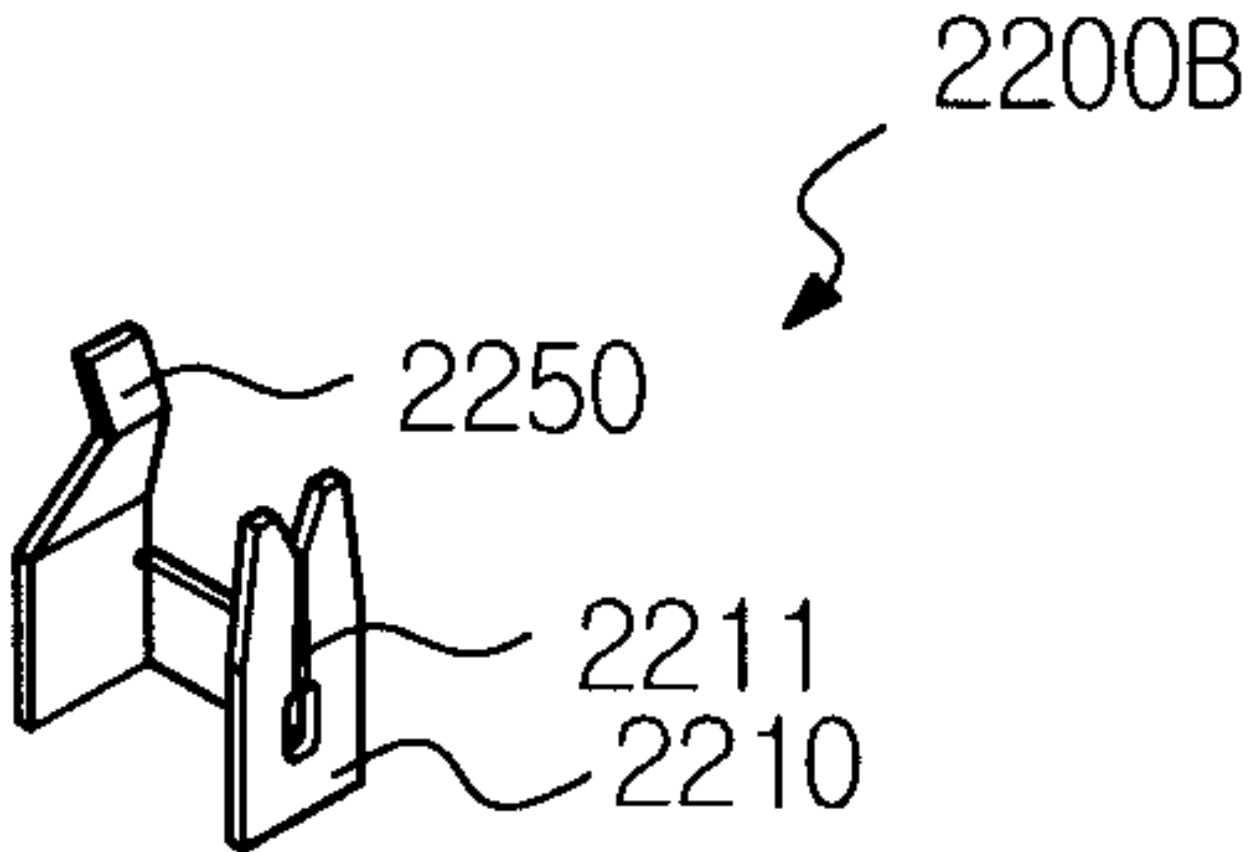

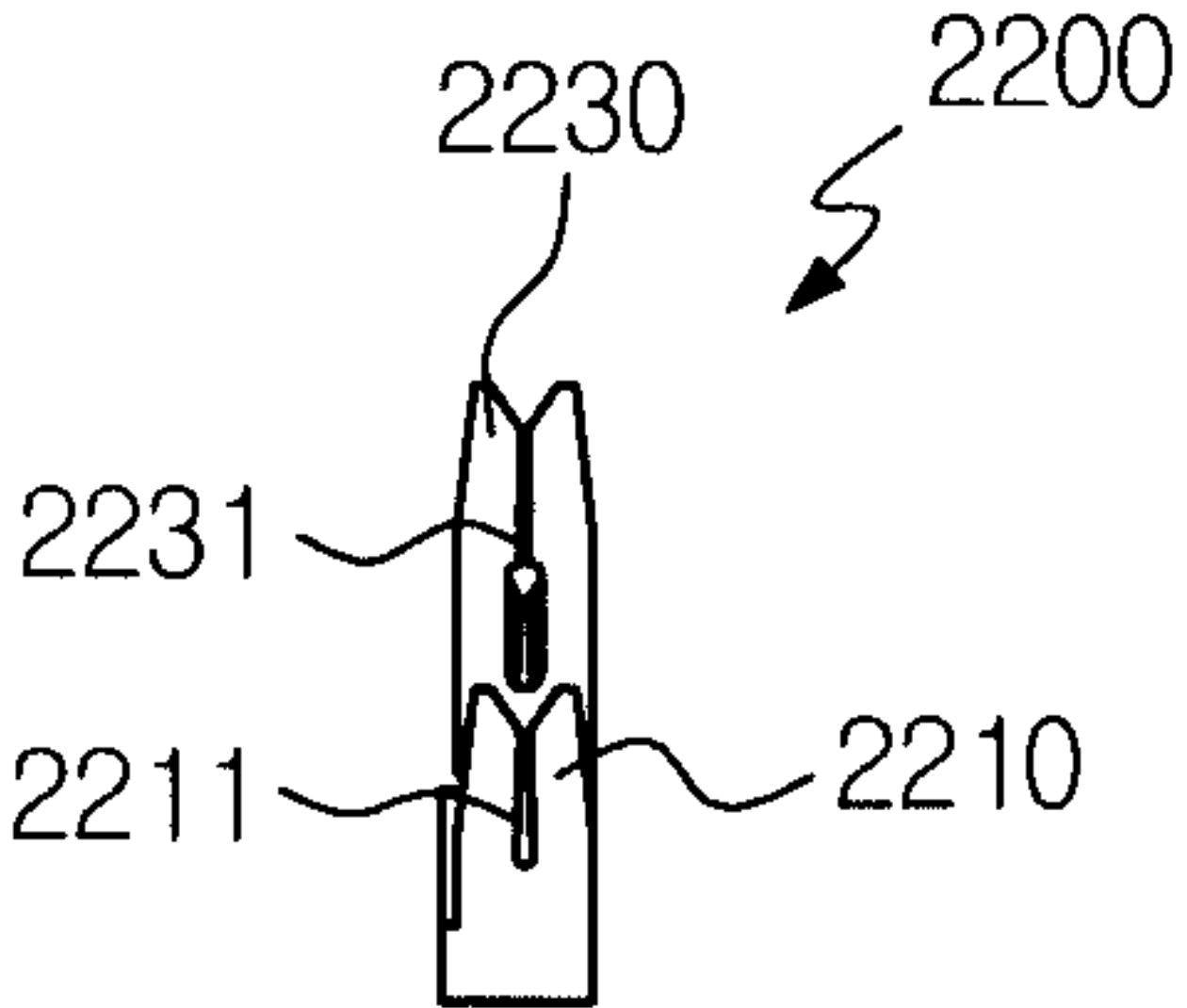

14a

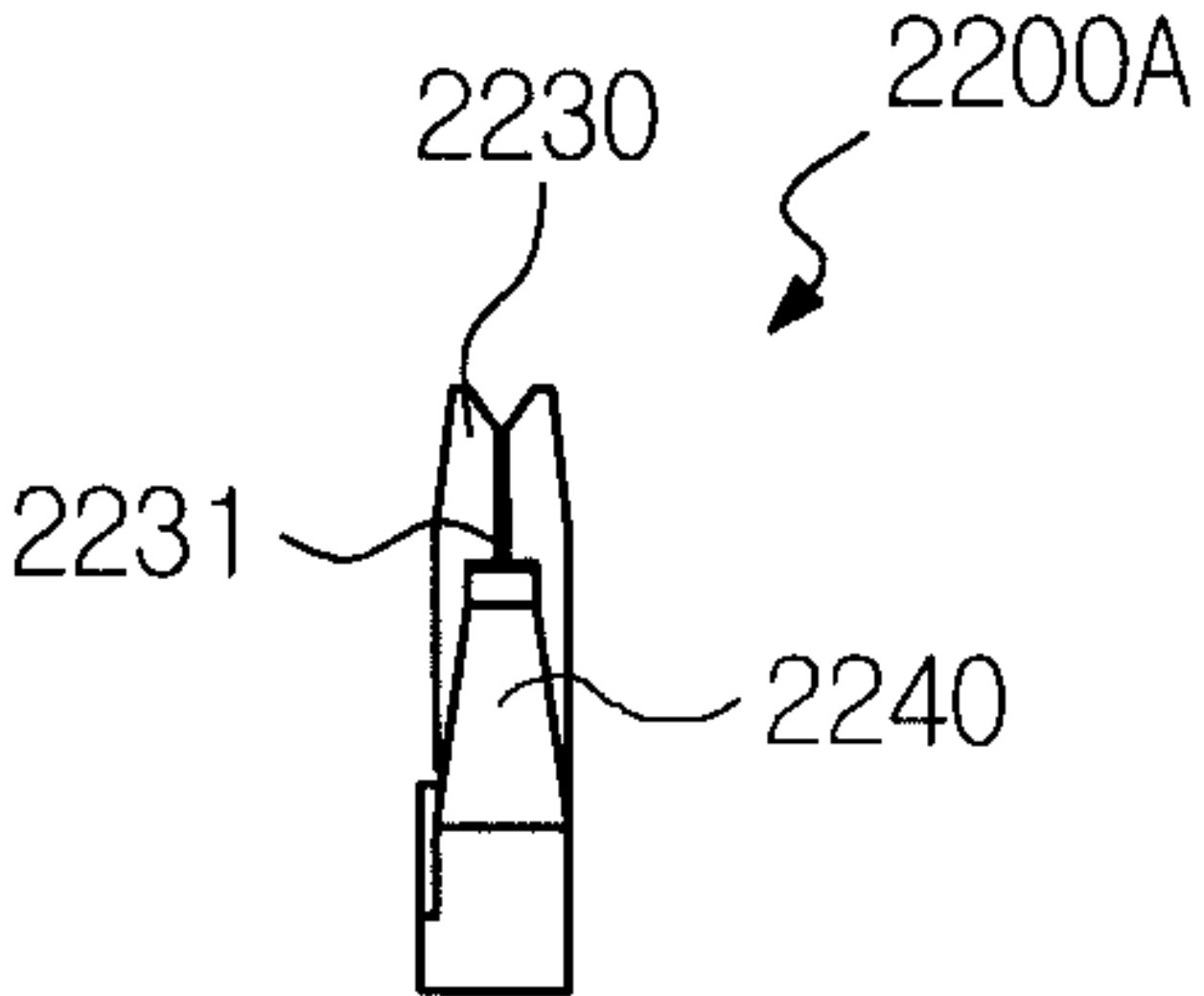

14b

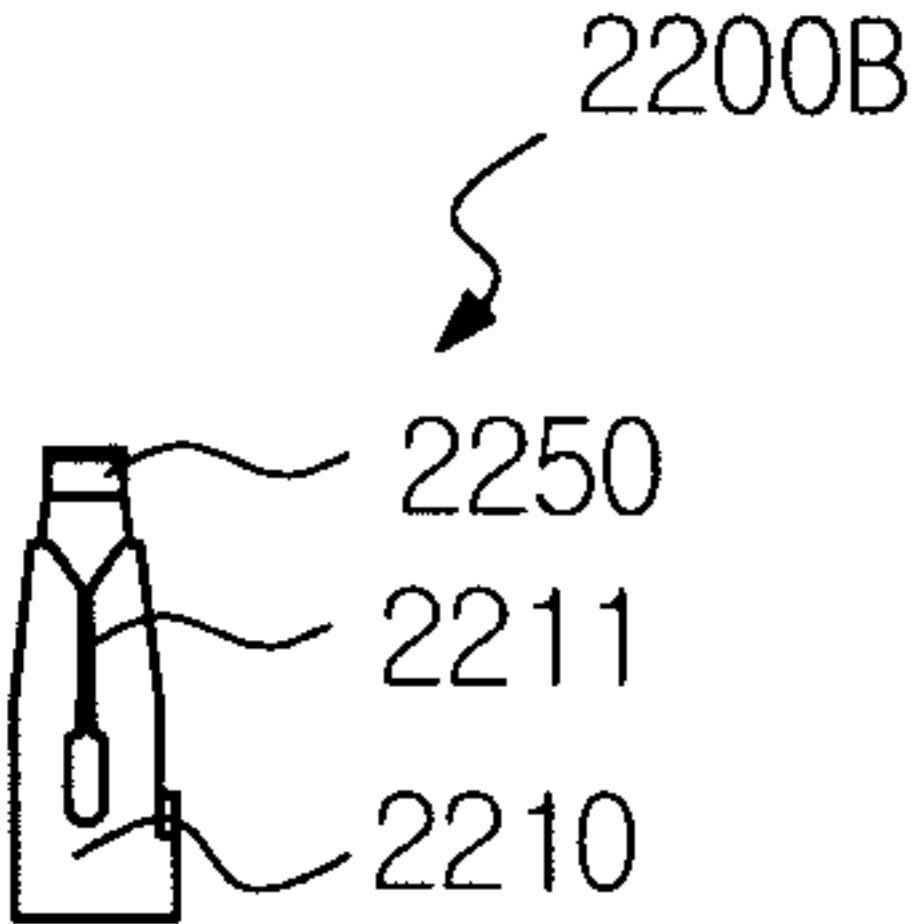

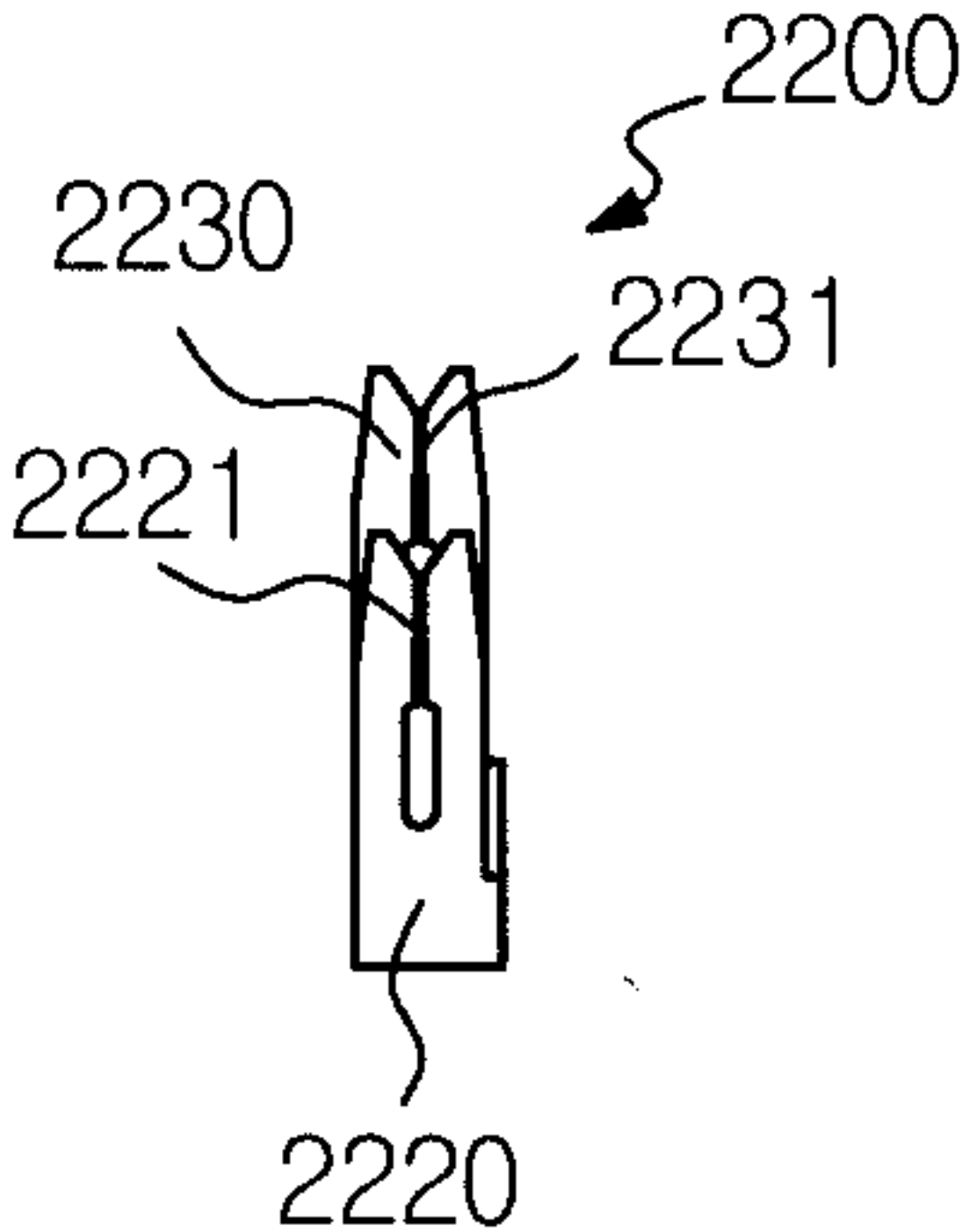

15a

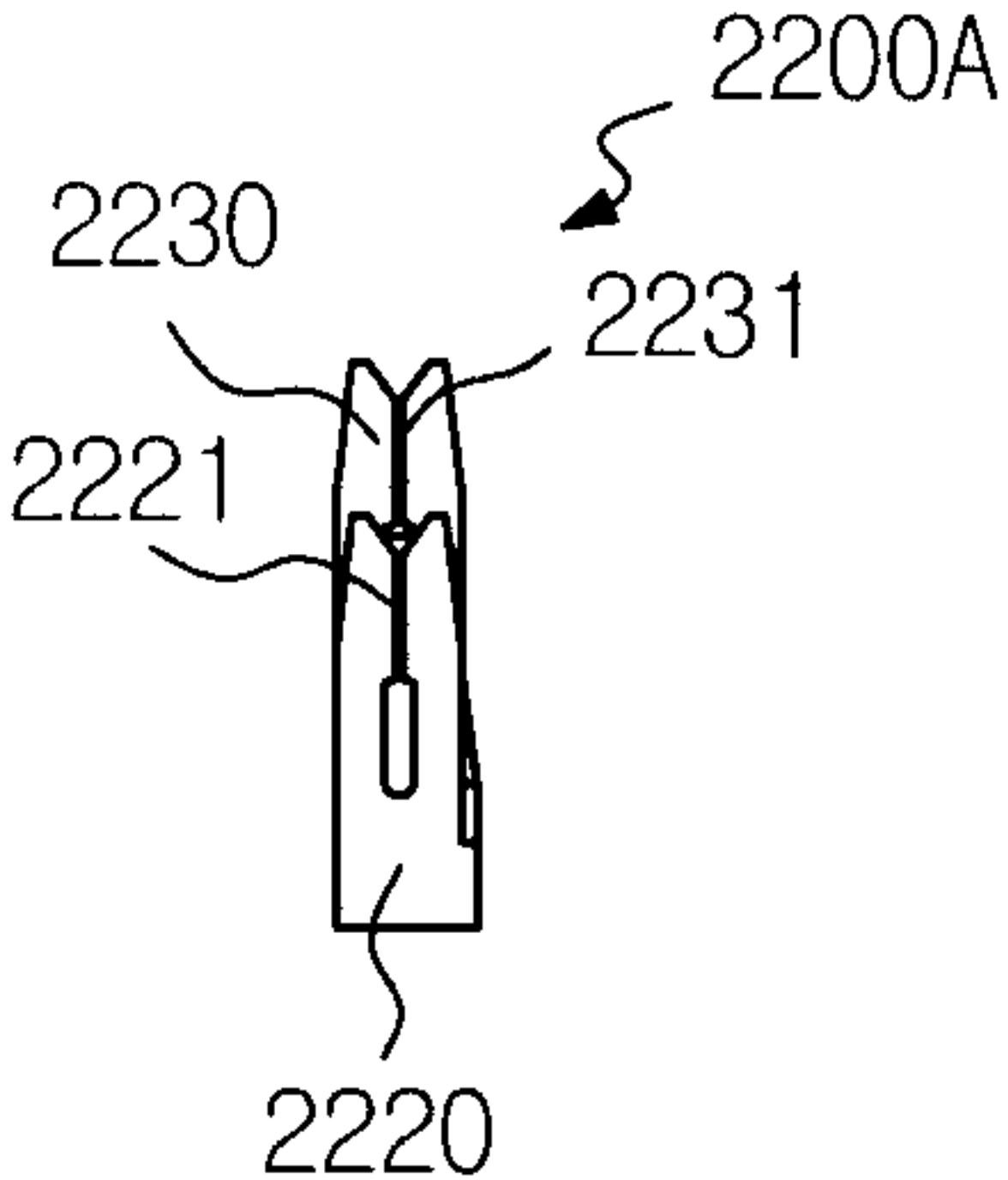

15b

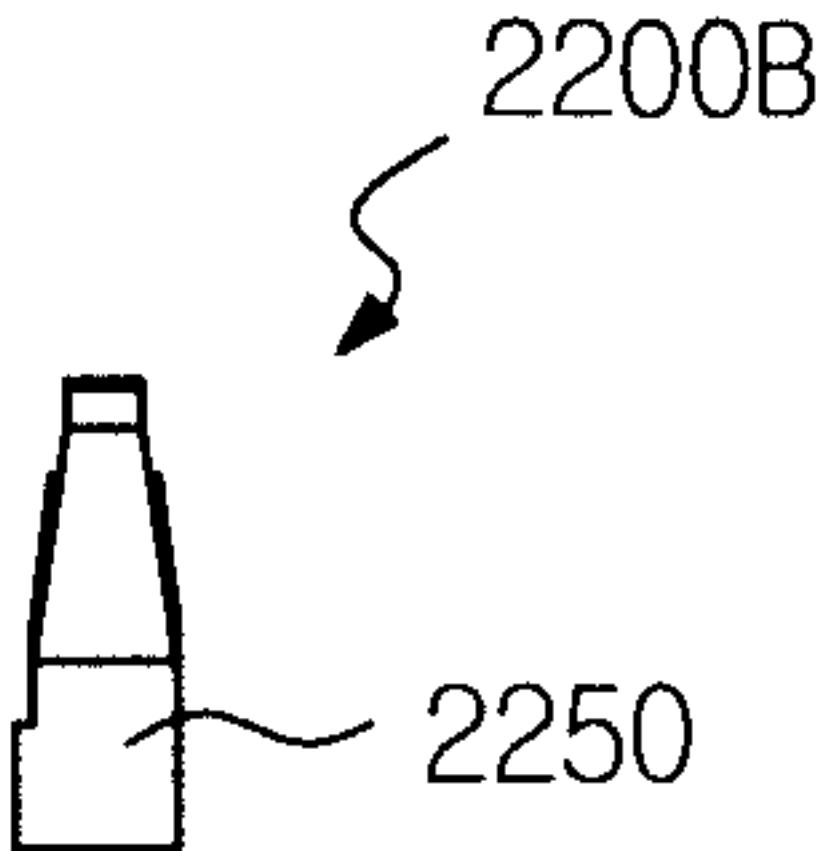

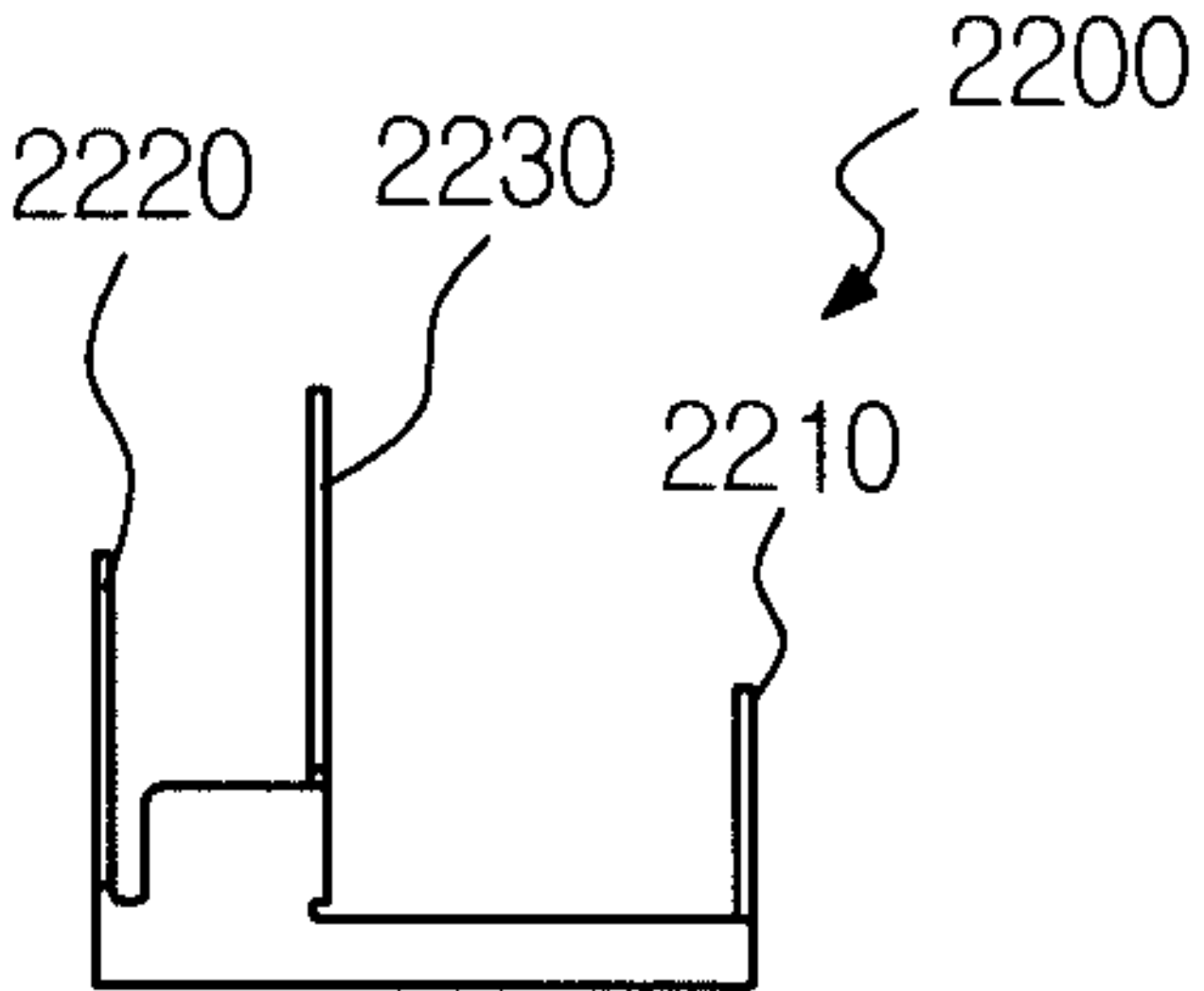

16a

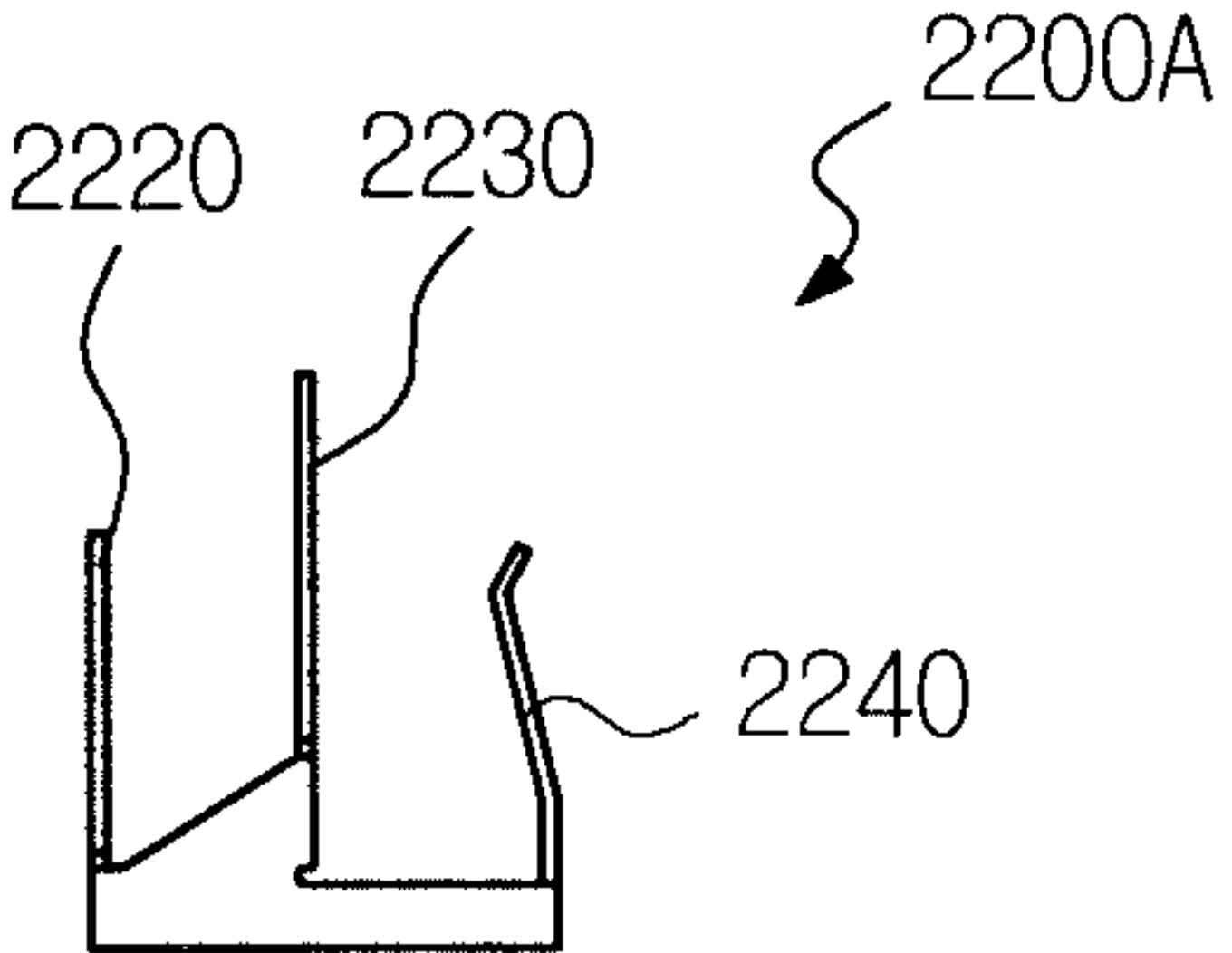

16b

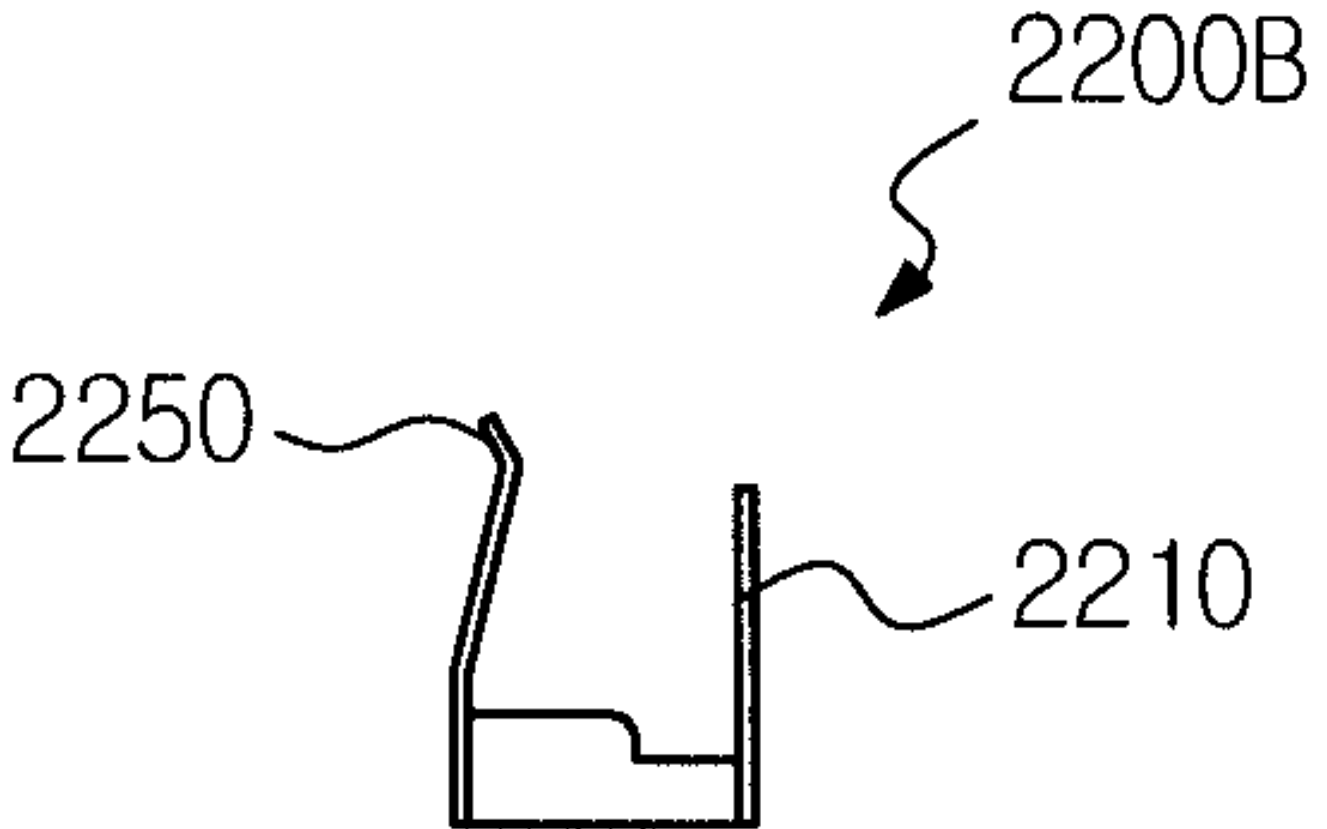

17

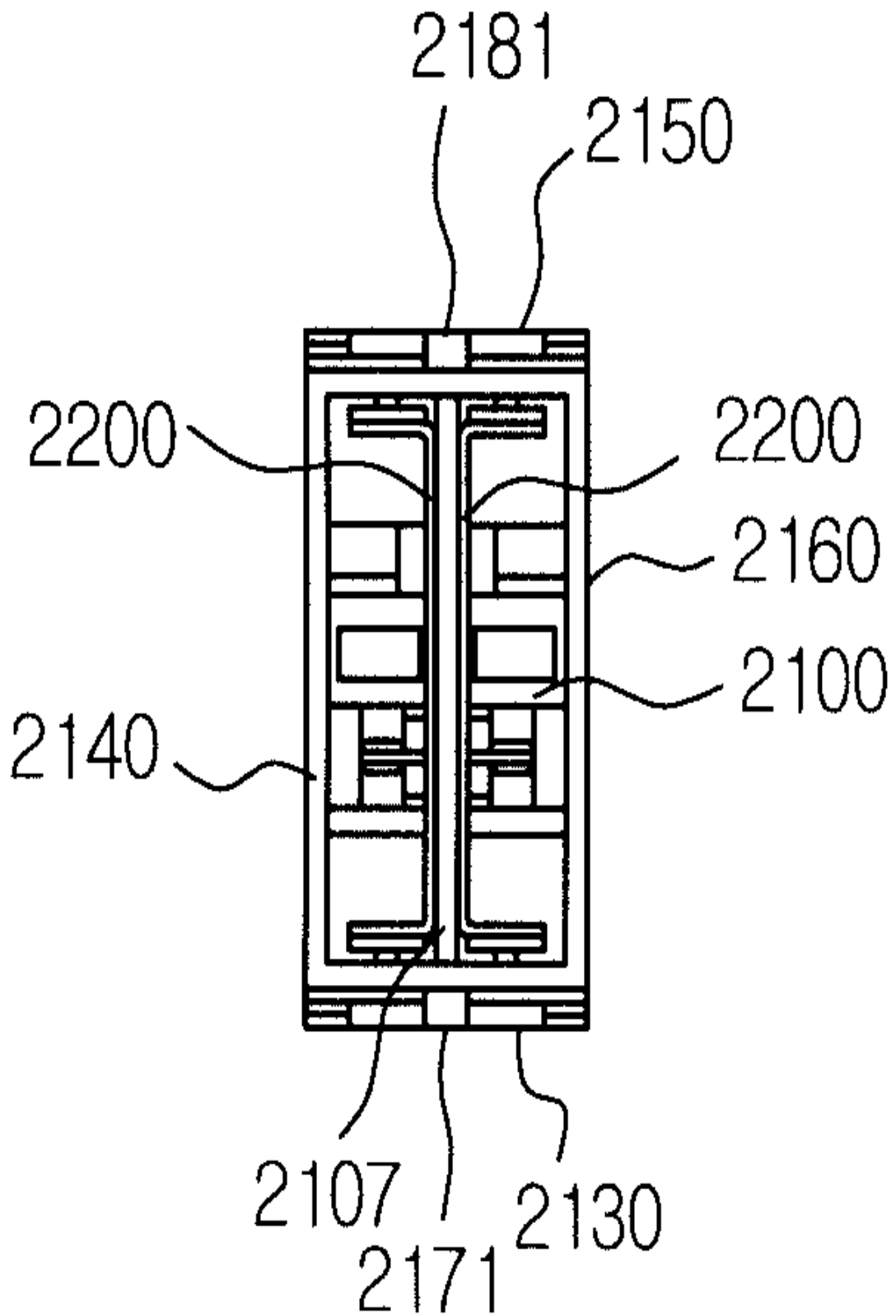

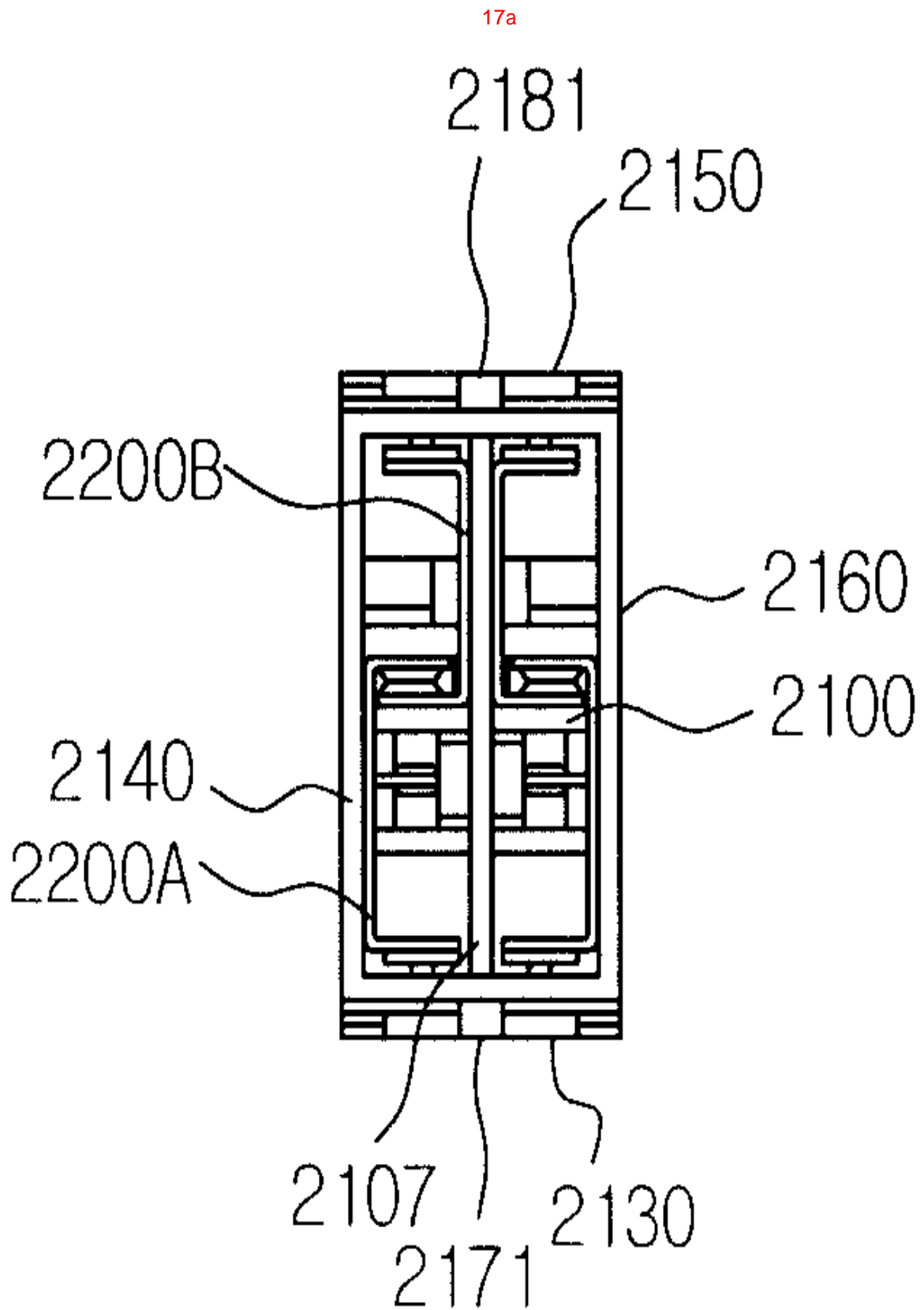

18

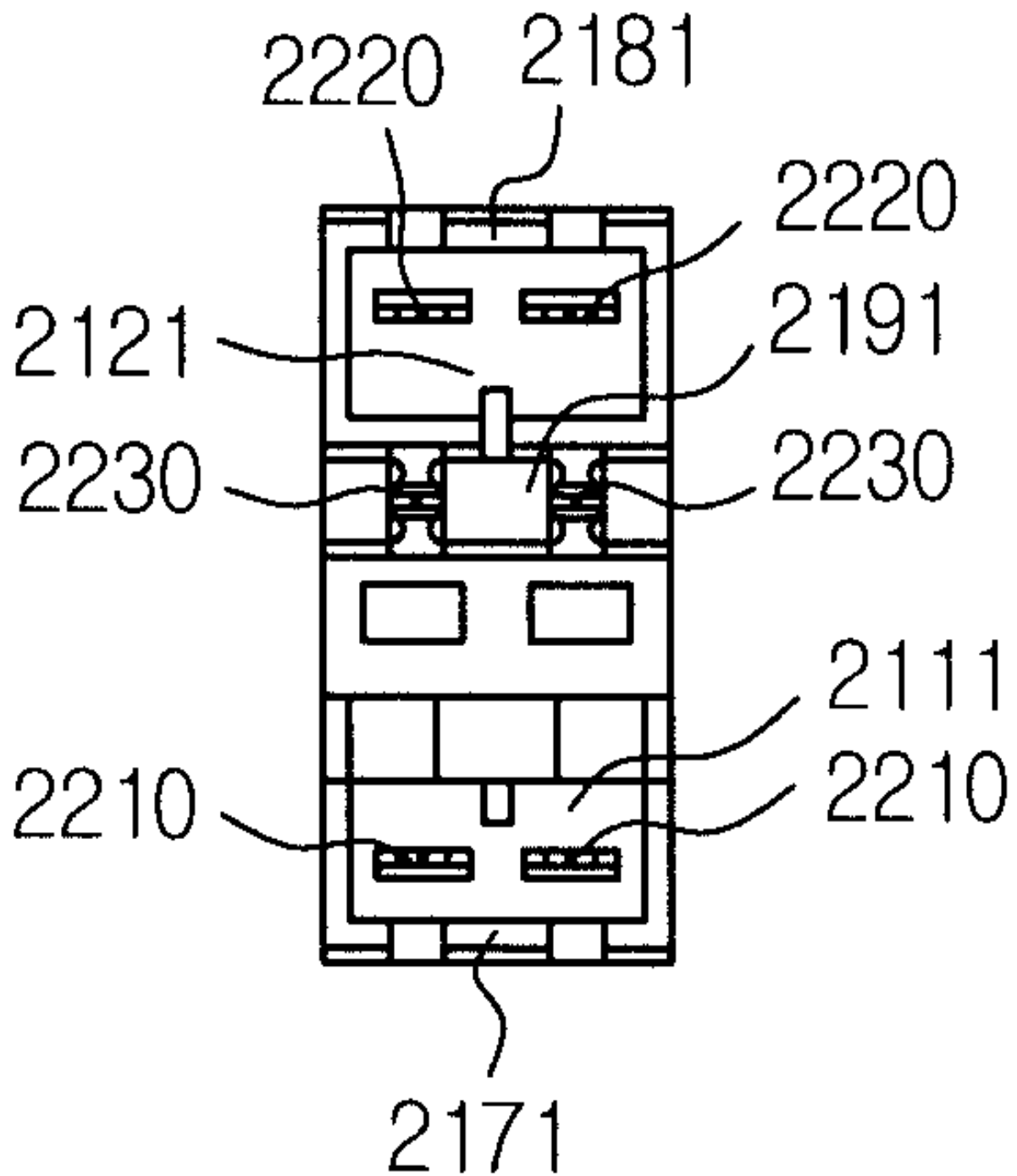

18a

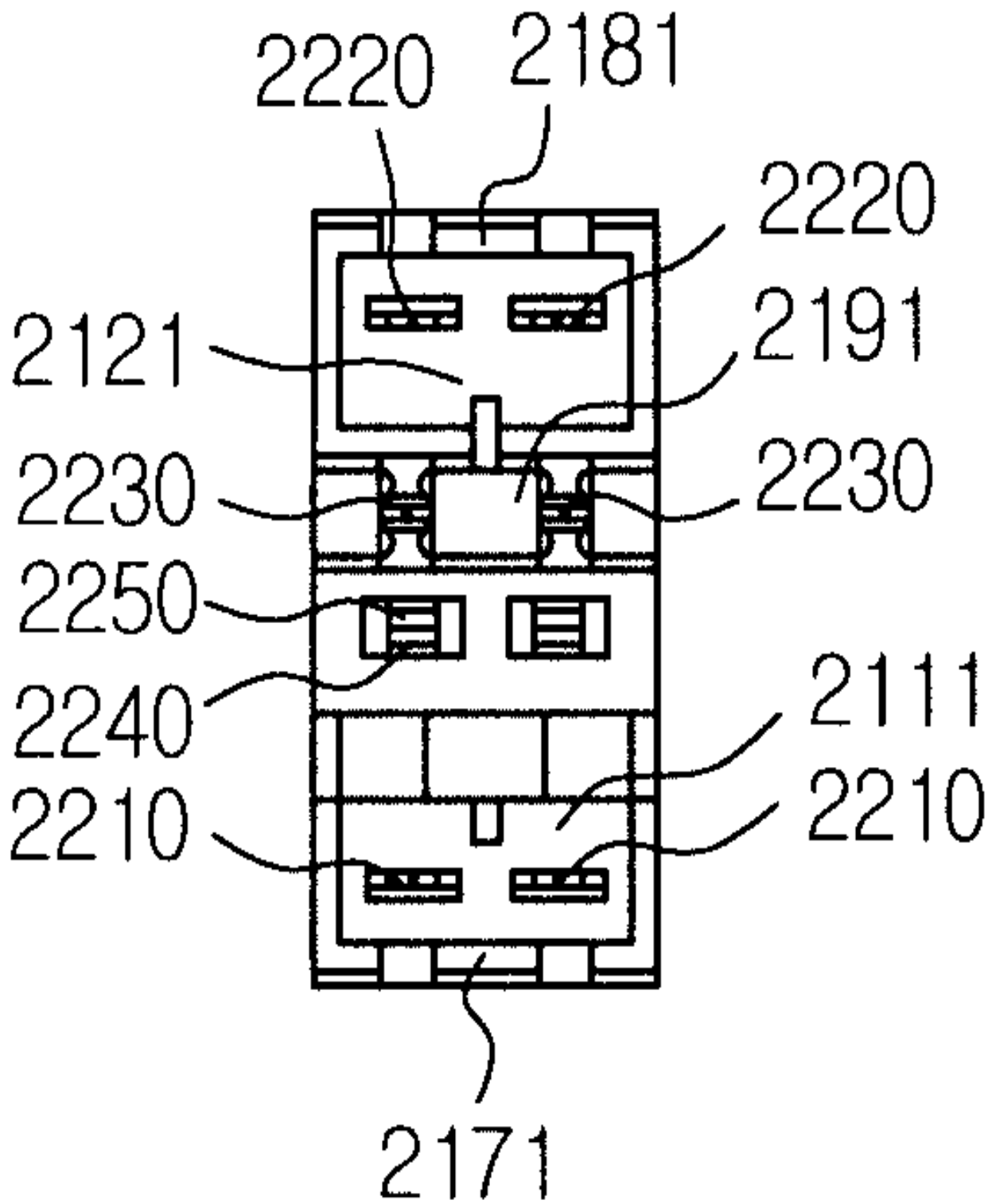

19

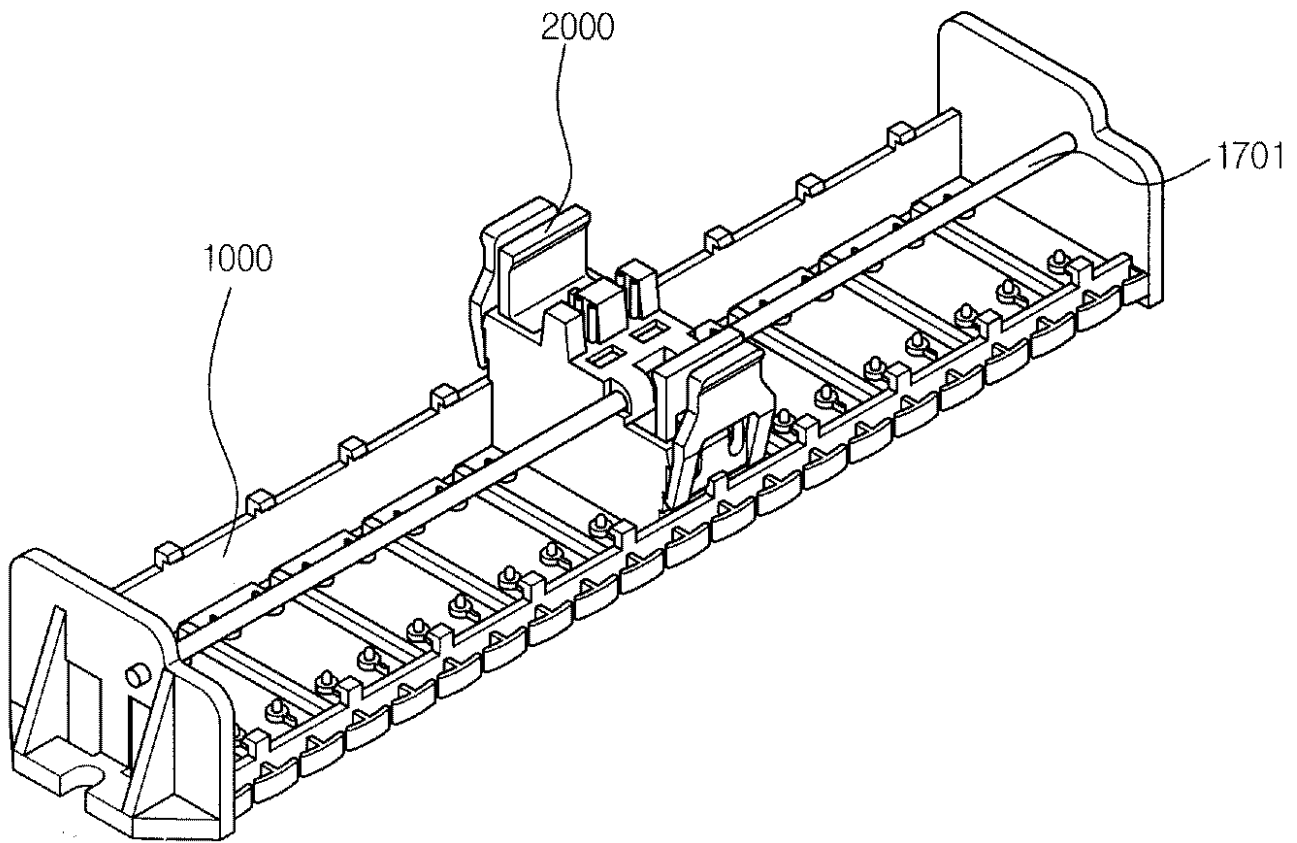

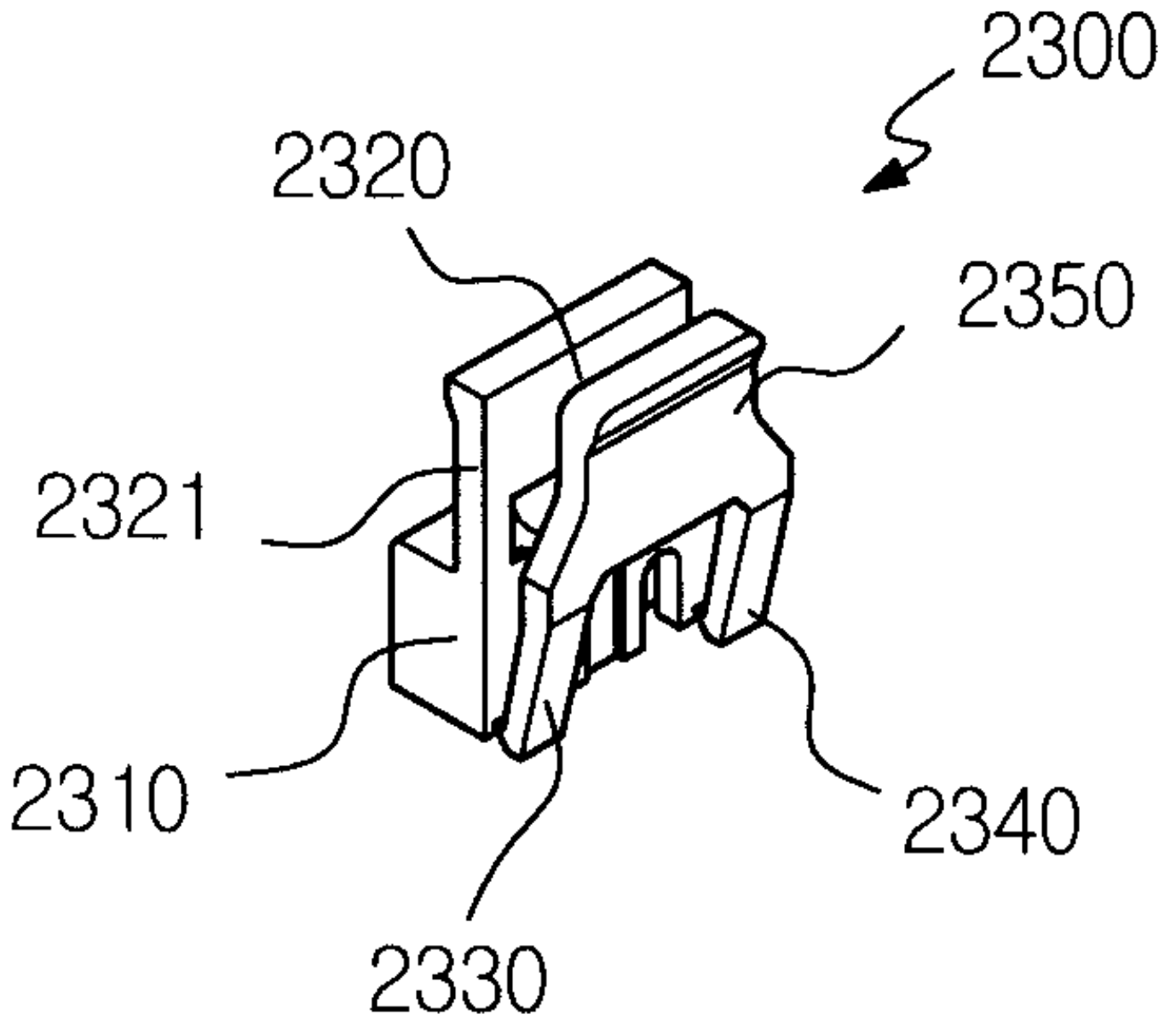

20

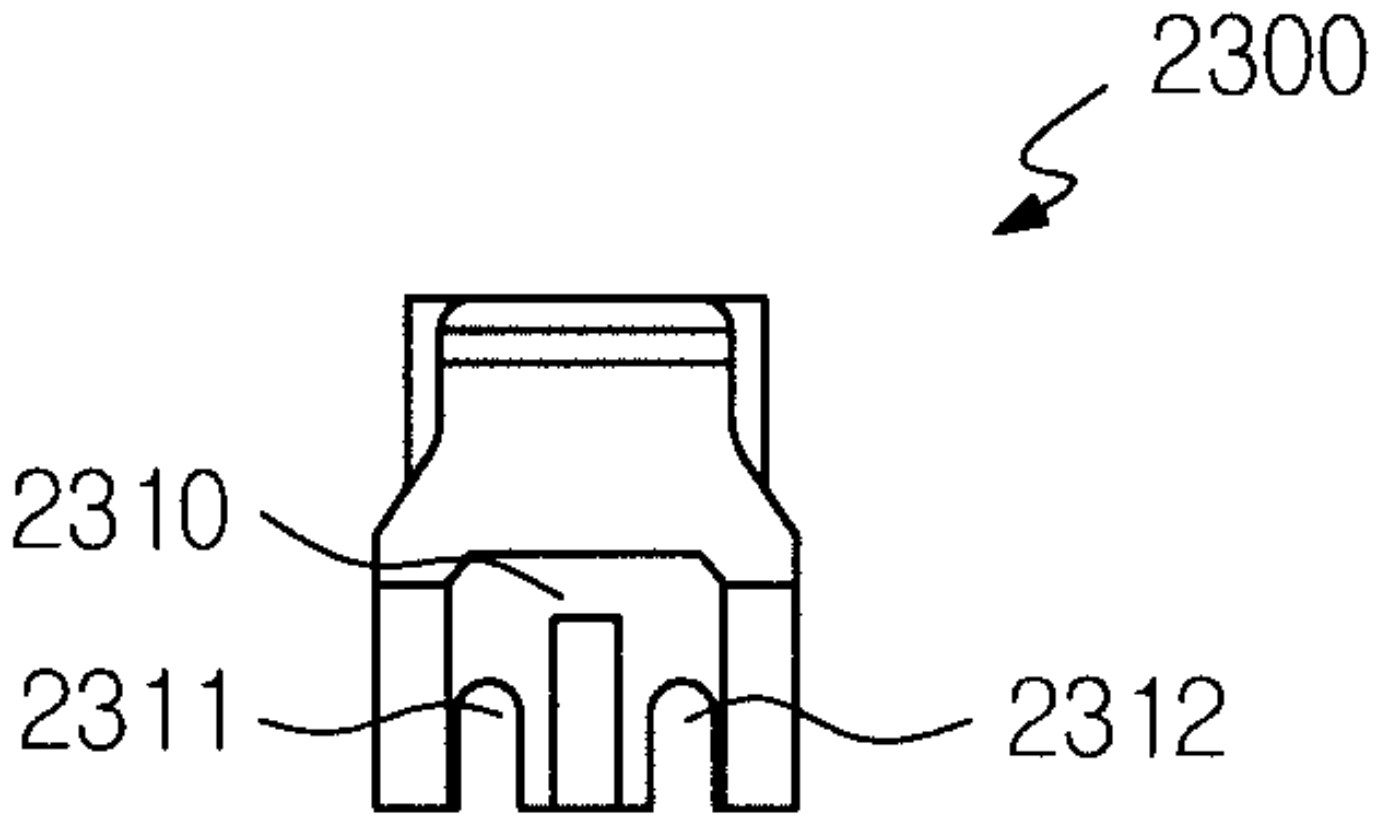

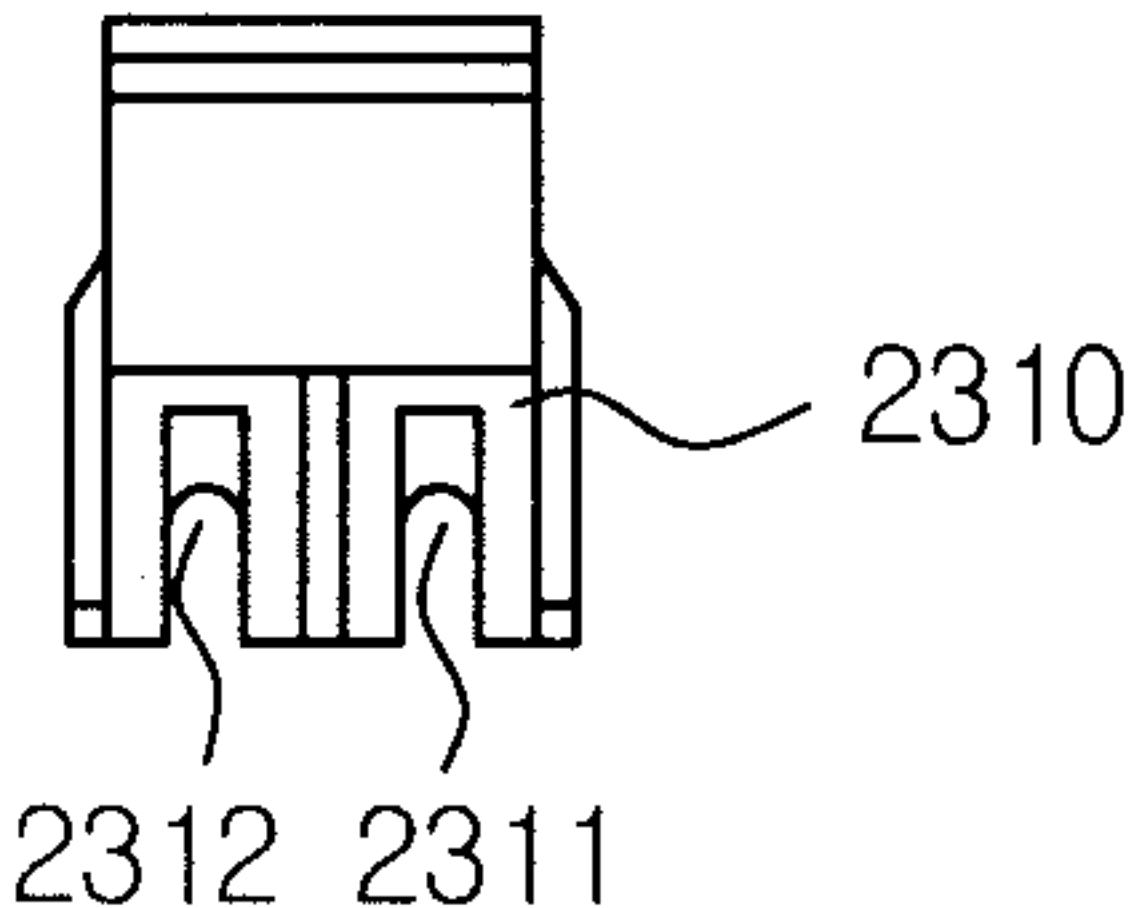

22

2300



23

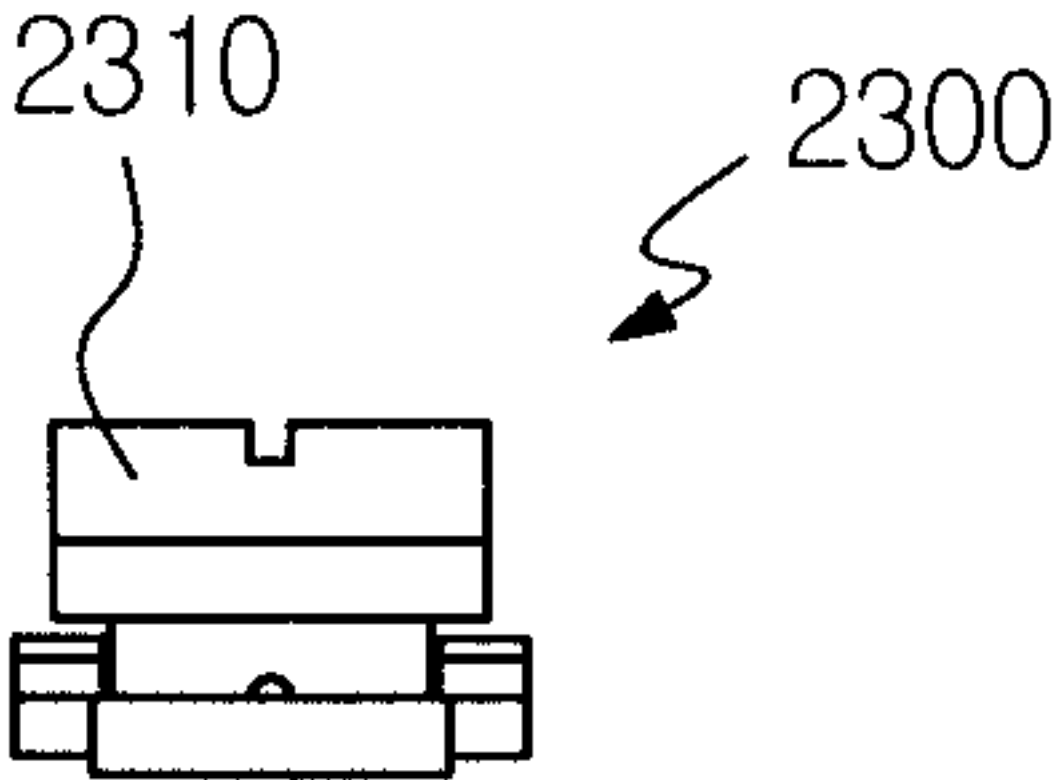

24

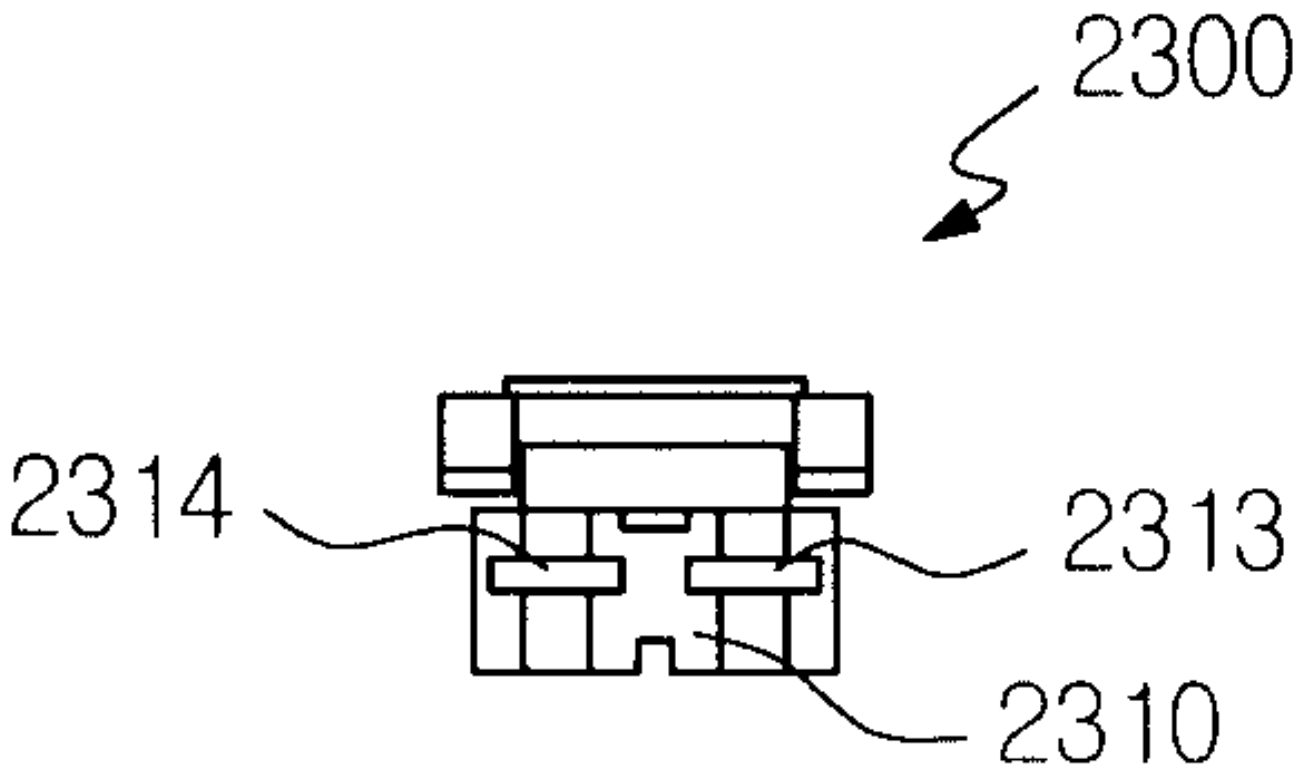

25

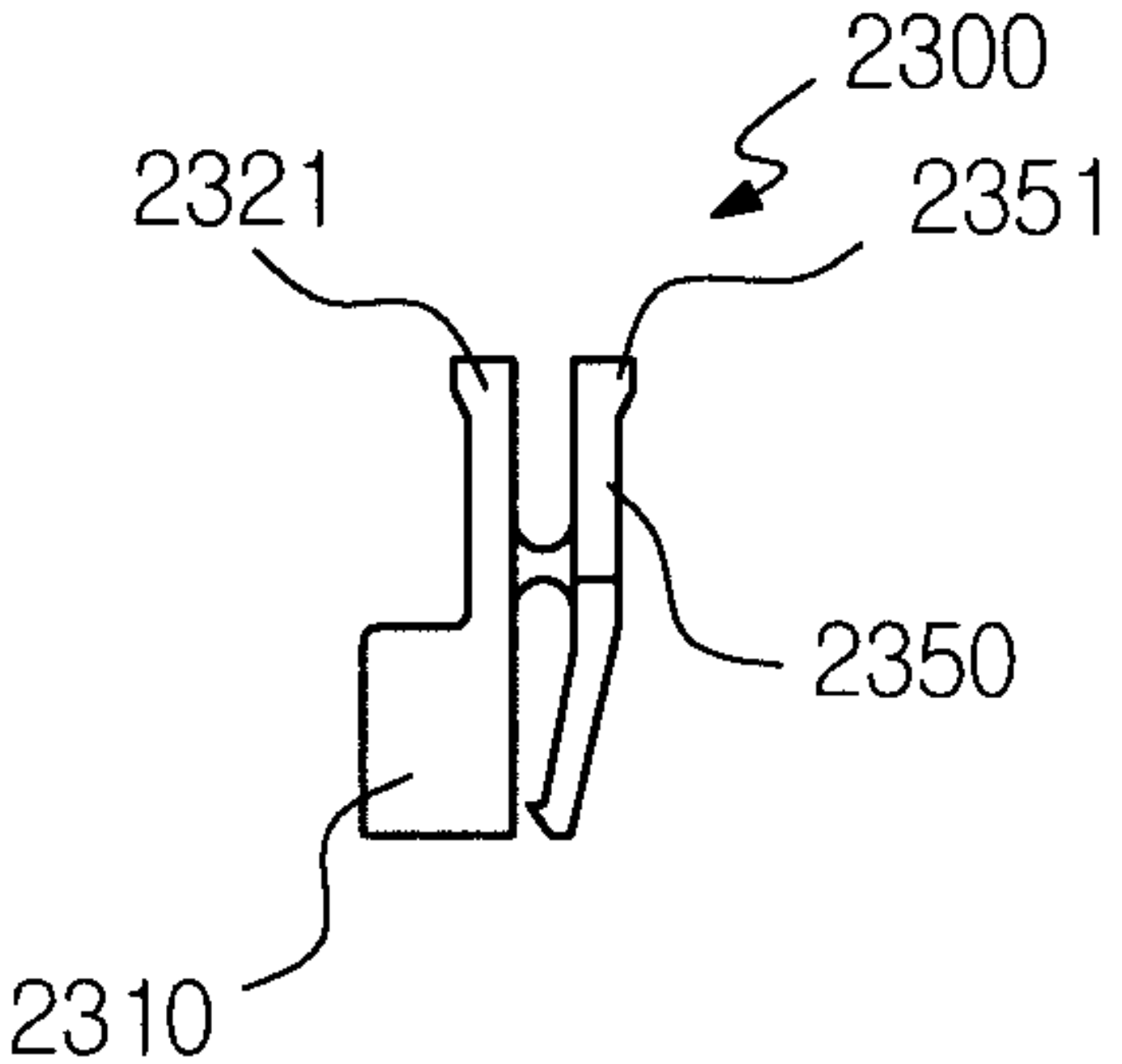

26

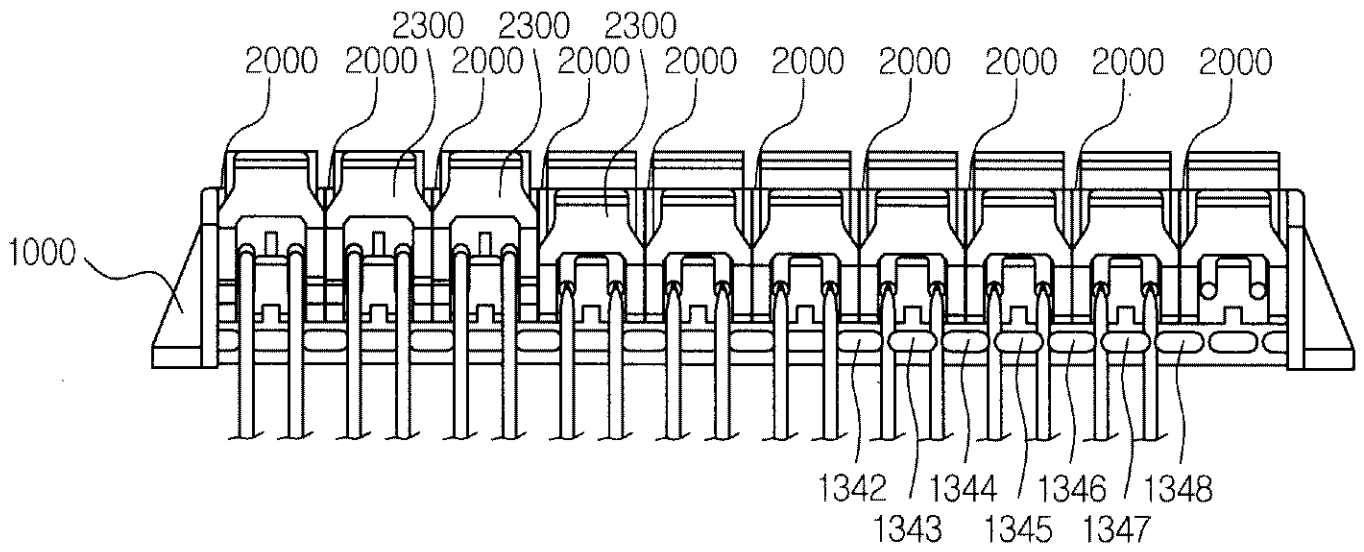

27

