

F. REICHMANN.
 PORTABLE BALANCE.
 APPLICATION FILED AUG. 23, 1909.

997,091.

Patented July 4, 1911.

Fig 1

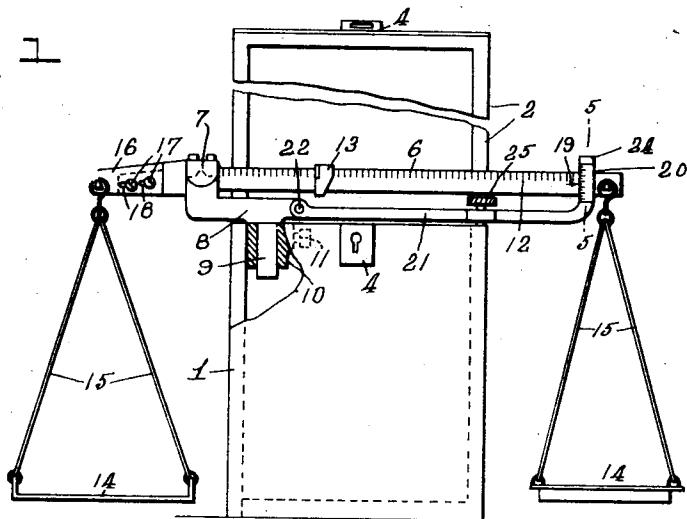

Fig 3

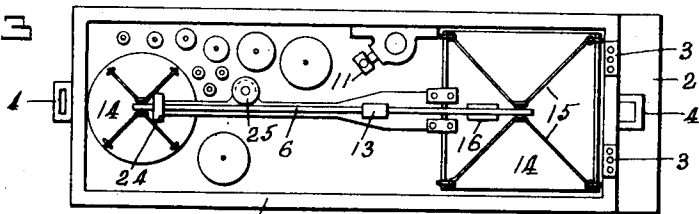

Fig 2

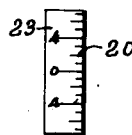
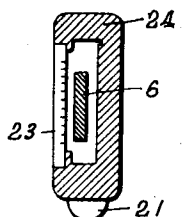
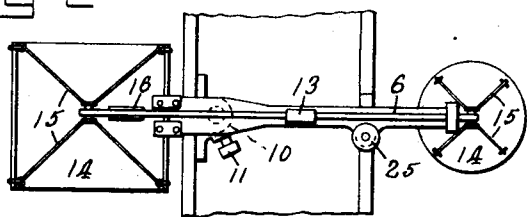
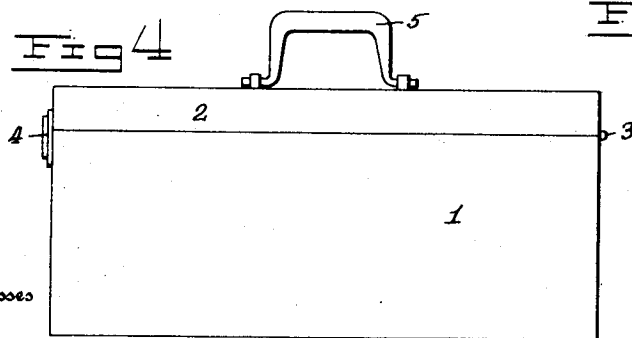

Fig 4



Inventor
 Fritz Reichmann

Witnesses

H. D. Polivette
G. M. Stucker

Moore & Curtis

Attorneys

UNITED STATES PATENT OFFICE.

FRITZ REICHMANN, OF WATERVLIET, NEW YORK.

PORTABLE BALANCE.

997,091.

Specification of Letters Patent.

Patented July 4, 1911.

Application filed August 23, 1909. Serial No. 514,200.

To all whom it may concern:

Be it known that I, FRITZ REICHMANN, a citizen of the United States, residing at Watervliet, county of Albany, and State of New York, have invented certain new and useful Improvements in Portable Balances, of which the following is a specification.

The invention relates to such improvements and consists of the novel construction and combination of parts hereinafter described and subsequently claimed.

Reference may be had to the accompanying drawings, and the reference characters marked thereon, which form a part of this specification.

Similar characters refer to similar parts in the several figures therein.

Figure 1 of the drawings is a view in front elevation of my improved portable balance set up ready for use. Fig. 2 is a top plan view of the same. Fig. 3 is a top plan view of the open box or case, with the folded balance and the weights therewithin. Fig. 4 is a view in side elevation of the box-inclosure or case for the balance. Fig. 5 is a vertical cross-section taken on the broken line 5—5 in Fig. 1, drawn on an enlarged scale. Fig. 6 is a view in elevation of the inner side of a glass scale-plate, shown in Figs. 1 and 5, for reading slight fluctuations of the balance-beam.

The principal object of the invention is to provide in portable form for the use of gagers and inspectors, a balance which can be readily set up wherever it is desired to use the same, and which will accurately show very slight variations or fluctuations of the scale-beam.

Other objects will appear in connection with the following description.

Referring to the drawings wherein the invention is shown in preferred form, 1, represents a box or inclosure adapted to contain various parts of the balance when folded for transportation, said box having a cover, 2, hinged at one end at, 3, and provided at the other end with a catch or lock, 4, which may be of any known form adapted to hold the cover in closed position. The box is provided with a lift-handle, 5, which may be of any known form.

The balance-beam, 6, is fulcrumed at, 7, upon a support or standard, 8, having a post, 9, adapted to fit a socket, 10, on the inner side of one of the side-walls of the box, and to be held in said socket by means

of a set-screw 11. The balance is thus in use mounted upon the box extending transversely thereof, with the ends of the beam projecting beyond the respective side-walls of the box. The fulcrum, 7, is preferably nearer one end of the beam than the other, and the longer arm of the beam is provided with graduations, 12, and with a poise, 13, movable along said graduated arm in the usual manner.

A scale-pan, 14, is suspended from each end of the beam by means of a pan-hanger 15.

The balance-beam has an adjustable member, 16, on its shorter end whereby the length of the shorter arm of the beam can be varied to accurately secure the desired ratio in the length of the respective beam-arms. The adjustable member, 16, is secured to the main part of the beam by screws, 17, inserted through slotted apertures, 18, in said adjustable member, the slotted apertures permitting the necessary adjustment, and the screws, 17, serving to firmly lock the adjustable member upon the body of the beam when properly adjusted. The longer arm of the beam is provided with an index-mark, 19, coöperative with a graduated scale, 20, carried by a scale-arm, 21, pivotally mounted at, 22, upon the support or standard, 8, in such a position that the scale, 20, extends vertically in close proximity to the side of the longer arm of the balance-beam bearing the index-mark 19. The scale-arm, 21, is also adjustably supported upon the top edge of a side-wall of the box by means of a screw, 25, inserted through a screw-threaded aperture in said scale-arm into engagement with said top edge of the side-wall. By adjustment of said screw, 25, the scale, 20, can be raised or lowered so as to bring the zero-mark on its scale opposite the index-mark, 19, on the balance-beam in the initial position of the balance-beam, whether the box, 1, be resting on a level support or not. When the balance-beam has been thus adjusted to secure the proper initial relationship between the scale, 20, and the index-mark, 19, the device can be used for weighing or balancing in the usual manner by means of the poise, 13, or by placing substantially equal weights in the respective scale-pans, or by adjustment of the poise, 13, and the use of weights of different values in the scale-pans, in each of which cases minute differences in the weight values car-

ried by the respective arms of the balance-beam will be indicated by the index-mark, 19, with reference to the scale 20.

5 The scale, 20, is preferably formed upon a plate of glass, 23, and a preferred manner of mounting said plate of glass upon the head, 24, of the scale-arm is illustrated in Fig. 5. The scale is preferably formed upon the back of said plate of glass, where it is in close proximity to the side of the beam which bears the index-mark, 19, in order to secure an accurate reading of the scale.

What I claim as new and desire to secure by Letters Patent is:

15 1. The combination with a foldable balance comprising in part a balance-beam, and a fulcrum-support therefor having a depending post; of a covered inclosure adapted to contain said balance when folded and placed longitudinally therewithin, said inclosure having therewithin adjacent one side thereof a socket adapted to removably receive said post, whereby said balance can be supported for use upon, and transversely of, the inclosure-body.

20 2. The combination with a foldable balance comprising in part a balance-beam having an index-mark, and a fulcrum-support therefor; of a covered inclosure adapted to contain said balance when folded; means whereby said fulcrum-support can be

supported at certain times upon said inclosure; a vertically adjustable scale-arm; means for accomplishing a vertical adjustment of said scale-arm; and a graduated scale carried by said scale-arm adjacent to the side of said balance-beam having said index-mark. 35

3. The combination with a foldable balance comprising in part a balance-beam having an index-mark, and a fulcrum-support therefor; of a covered inclosure adapted to contain said balance when folded, said inclosure having means whereby said fulcrum-support can be mounted thereupon with the balance-beam extending transversely of, and above, the inclosure-body; a scale-arm pivoted to said fulcrum-support in position to overhang one of the side-walls of said inclosure; a screw inserted through a screw-threaded aperture in said scale-arm, and engageable with the top of said side-wall whereby said scale-arm can be vertically adjusted; and a scale carried by said scale-arm adjacent to the side of said balance-beam having said index-mark. 40 45 50 55

In testimony whereof, I have hereunto set my hand this 13th day of August, 1909.

FRITZ REICHMANN.

Witnesses:

MARK L. FILLEY,
JOSEPH DUNKERLEY.

Copies of this patent may be obtained for five cents each, by addressing the "Commissioner of Patents, Washington, D. C."