

C. Sharps,

Screw Propeller.

No. 109458.

Patented Nov. 22. 1870.

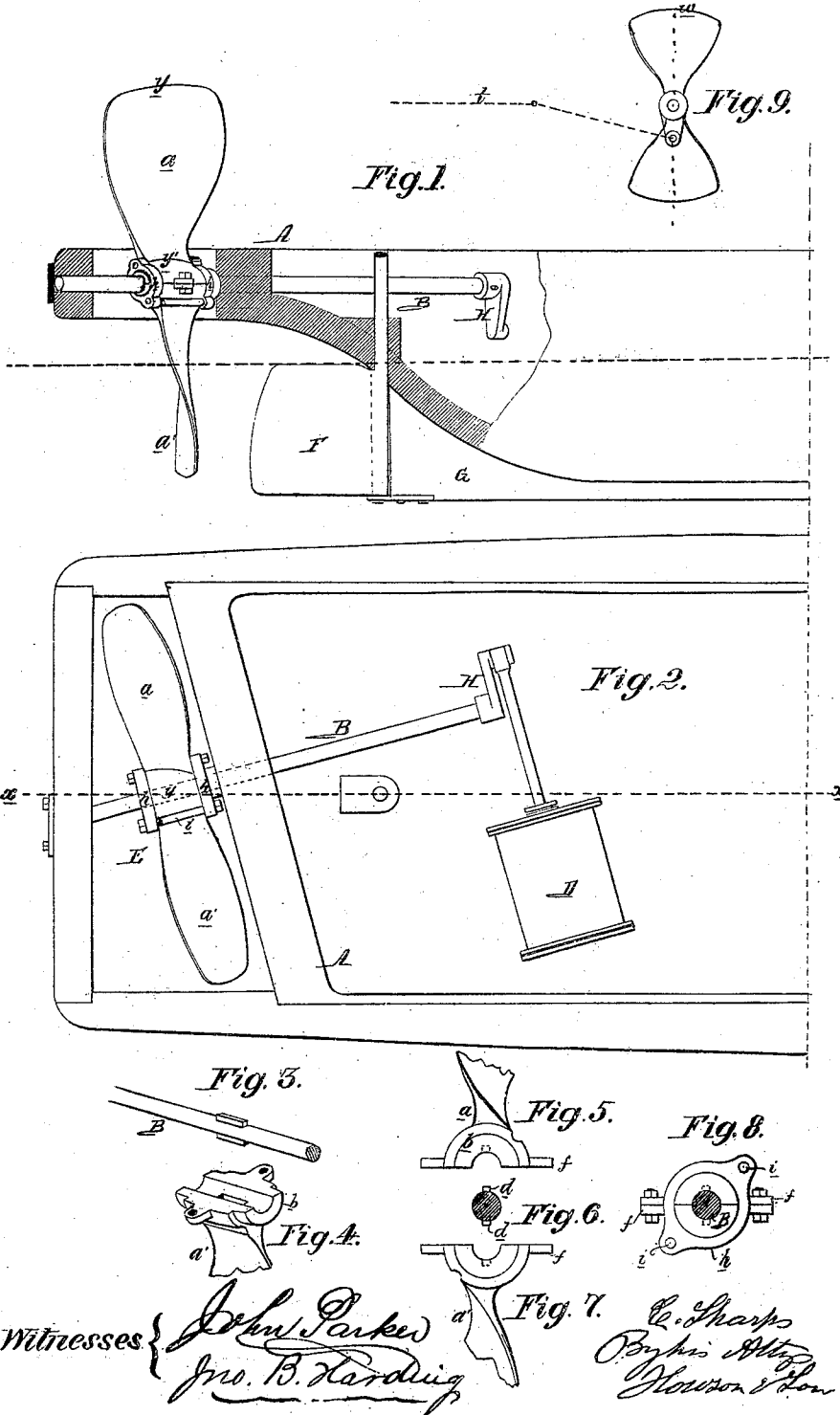

Witnesses { *John Parker*
Jno. B. Harding

C. Sharps
By his Attys
Glowson & Son

United States Patent Office.

CHRISTIAN SHARPS, OF PHILADELPHIA, PENNSYLVANIA.

Letters Patent No. 109,458, dated November 22, 1870.

IMPROVEMENT IN PROPELLING MECHANISMS.

The Schedule referred to in these Letters Patent and making part of the same.

I, CHRISTIAN SHARPS, of Philadelphia, county of Philadelphia, State of Pennsylvania, have invented certain Propelling Mechanism for Vessels, of which the following is a specification.

Nature and Object of the Invention.

My invention relates to improvements in the propelling mechanism for which Letters Patent were granted to me on the 25th day of May, 1869, also on the 21st of September, 1869, the main feature of the said patented propelling mechanism consisting of a non-submerged wheel, or a wheel with a limited dip, and having inclined blades, and secured to an inclined shaft, and partaking of the character of a paddle-wheel as well as of a screw propeller.

My present improvements, which are based upon the result of repeated and costly experiments, consist in the combination of an inclined shaft with a propeller having blades which are sections of differential screw-threads, as explained hereafter, the shaft of the propeller being, in all cases, above the water-line.

The object of this feature of my invention is to obtain a propeller-wheel of large diameter, which shall have the best effect in shallow water, shall clear the latter readily, and shall cause but little swell.

My invention further consists of a two-bladed propeller, arranged on an inclined shaft in respect to the center line of the engine and crank in the manner described hereafter, so that there may be but little resistance to the passage of the crank over its dead-centers, and so that the engine may be uniform in its action, and its power exerted through the most advantageous medium, and in proportion to the duty which it has to perform.

Also, of a peculiar propeller, described hereafter, made with the view to economy and facility, both as regards original construction, and repairing in case of accidents.

The main object of my improvements has been to obtain a propeller applicable to light-draught vessels for navigating narrow and shallow rivers, creeks, &c., and also as an auxiliary propelling medium for schooners and other light-draught vessels, the sails of which are of little use in narrow and tortuous creeks.

Description of the Accompanying Drawing.

Figure 1 is sectional view of the stern of a vessel with my propelling mechanism.

Figure 2, a plan view.

Figures 3, 4, 5, 6, 7, and 8, views illustrating the peculiar construction of the propeller.

Figure 9, a diagram illustrating one feature of my invention.

General Description.

A represents the projecting stern of a vessel;
B, the propeller-shaft;

D, the steam-cylinder of the driving-engine;
E, the propeller;
F, the rudder; and
G, the keel.

The propeller-shaft B is placed at an angle in respect to a longitudinal midship line, xz , and I have ascertained by repeated experiments that the best results may be obtained when this angle is between fifteen and twenty degrees in respect to that line.

The propeller has two blades, a and a' , each of which is the section of a screw-thread, in the present instance of a differential screw-thread; that is to say, the inclination of the blade at its extreme outer edge, y , is more abrupt in respect to the center line of the shaft than it is at its junction, y' , with the hub, or, in other words, the pitch of the thread decreases in extent from the hub outward. It should be understood, however, in the outset, that the blade need not be a section of a differential screw-thread under all circumstances, a subject which will be referred to hereafter.

One of the prominent features of my invention is the relative positions of the two-bladed propeller and center line of the engine and crank. This arrangement will be best observed by referring to the diagram, fig. 9, in which t represents the center line of the engine, situated at right angles to the center line w of the propeller when the crank is at half-stroke, and one blade is at its greatest depth in the water.

If the central line of the cylinder is horizontal, as shown, and passes through the center of the propeller-shaft, the central line w of the propeller will be coincident with a line drawn through the center of the shaft and center of the crank-pin; hence the crank will pass over its dead-center easily, for, when the crank is at either of its dead-centers, the propeller-blades, or the greater portion of the same, will be out of water, while the crank will be in the best position for transferring the power of the engine to the propeller when one of its blades is in the water and the greatest power is required. The result of this arrangement must be the easy passage of the crank over its dead-centers, uniformity in the speed of the engine, and the transmission of the power of the same to the best advantage, and in accordance with the duty it has to perform.

Another important feature of my invention is the peculiar construction of the propeller and the mode of securing the same to the shaft, as illustrated in figs. 3, 4, 5, 6, 7, and 8.

The blades are cast separately, and are secured together and to the shaft at the hub b .

The shaft has two keys or feathers, d d' , one adapted to a recess in the half-hub of one blade, and the other to a like recess in the half-hub of the other blade, and the two half-hubs are connected together and confined to the shafts by bolts passing through lugs f f .

As a further security, however, the hub of the pro-

propeller has, at each end, a tapering projection adapted to the tapering interior of a ring, *h*, and the two rings are connected together by bolts, *i i*, figs. 1 and 2, on tightening the nuts of which the rings will be drawn toward each other, and the two half-hubs of the blades will be securely confined to each other and to the shaft. Two advantages are obtained by this feature of my invention; first, but one pattern is required from which both blades can be molded; and second, if a blade be broken, that blade only, and not the entire wheel, has to be discarded to make way for a new blade.

In carrying out my invention it is preferable, in most cases, that the blade should be a section of a differential screw-thread.

My propelling mechanism has been designed for small light-draught vessels for the navigation of shallow rivers, creeks, &c. Repeated and long-continued experiments have convinced me that for such vessels a propeller with the center of its inclined shaft above the water-line and blades forming sections of screw-threads forms the most available propelling medium, as the blades clear themselves from the water readily and cause but little swell.

I may remark here that the experimental vessel, which I have built and repeatedly tested, is seventy-five feet in length, has sixteen feet beam, and a draught of three feet, and has a single engine with a cylinder fourteen inches in diameter and fourteen inches stroke, the pressure of steam being about seventy-five pounds per square inch; that the propeller is eight feet in diameter and has a dip of three feet, the propeller-shaft being arranged at an angle of seventeen degrees in respect to the central midship line of the vessel, and each of the two blades being a section of a differential screw-thread. The propeller made about one hundred revolutions per minute, and the average speed of the vessel was about fourteen miles per hour. I give these dimensions and particulars as successful results were obtained by the vessel in question, not because they should be adhered to exactly under all circumstances, for vessels of different sizes, draught, and power, may require different dimensions of propellers and blades, and different inclinations of the blades.

My invention may be applied with advantage as an auxiliary propelling medium to schooners and other sailing vessels, especially such as have to navigate tortuous rivers and creeks, where sails are of little use,

but where a propeller would be of the greatest aid, the propeller being simply adjusted to a horizontal position, clear of the water, when sails alone are used.

When my mechanism is used as an auxiliary propelling medium, I use two blades only, and arrange the rudder as shown in fig. 1; but when used as the sole propelling medium of a vessel, I arrange the rudder astern of the propeller, which may have more than two blades.

In carrying out my invention, a propeller with simple flat inclined blades would not serve the desired purpose. As remarked above, the blades must be sections of a screw-thread.

I am aware that such propellers have been heretofore used, but they have been submerged and placed on shafts parallel with the keel, whereas my propeller, with its screw-blades, has a limited dip in the water and is secured to an inclined shaft, and it is these three features in combination, namely, a wheel of large diameter and having a limited dip, blades forming sections of screw-threads, and an inclined propeller-shaft, by which the successful results have been attained, and which constitutes one feature of my invention.

I have also remarked above that a differential screw-blade is to be preferred, but a regular screw-blade may be used in a wheel of large diameter and very slight dip.

Claims.

1. The combination of an inclined shaft with a propeller having blades which are sections of differential screw-threads, decreasing in the extent of pitch from the hub outward, when the whole is so applied to a vessel that the said shaft shall be above the water-line.

2. A two-bladed propeller, arranged on an inclined shaft in respect to the center line of the engine and crank, as set forth.

3. A propeller, consisting of two separate blades, secured together and to the shaft by rings *h h* and bolts *i i* applied to the hub, substantially as described.

In testimony whereof, I have signed my name to this specification in the presence of two subscribing witnesses.

CHRISTIAN SHARPS.

Witnesses:

WM. A. STEEL,

FRANK B. RICHARDS.