



US00D735244S

(12) **United States Design Patent**
Jeong et al.

(10) **Patent No.:** **US D735,244 S**

(45) **Date of Patent:** **** Jul. 28, 2015**

- (54) **COMPRESSOR FOR VEHICLES**
- (71) Applicant: **HALLA VISTEON CLIMATE CONTROL CORP.**, Daedeok-gu, Daejeon (KR)
- (72) Inventors: **Soo Cheol Jeong**, Daejeon (KR); **Kweon Soo Lim**, Daejeon (KR); **Hong Min Kim**, Daejeon (KR)
- (73) Assignee: **Halla Visteon Climate Control Corp.**, Daedeok-Gu, Daejeon (KR)

D537,843 S	*	3/2007	Chu	D15/9
D624,095 S	*	9/2010	Chu	D15/9
D695,789 S	*	12/2013	Nam	D15/9
D710,395 S	*	8/2014	Park et al.	D15/9
D710,905 S	*	8/2014	Park et al.	D15/9
D710,906 S	*	8/2014	Park et al.	D15/9
D710,907 S	*	8/2014	Lim et al.	D15/9
D710,908 S	*	8/2014	Son et al.	D15/9
D710,909 S	*	8/2014	Kim et al.	D15/9
D715,326 S	*	10/2014	Lim et al.	D15/9
D715,327 S	*	10/2014	Lim et al.	D15/9

* cited by examiner

Primary Examiner — Ralf Seifert

(74) *Attorney, Agent, or Firm* — Dickinson Wright PLLC

- (**) Term: **14 Years**
- (21) Appl. No.: **29/503,272**
- (22) Filed: **Sep. 24, 2014**

(57) **CLAIM**

We claim the ornamental design for a compressor for vehicles, as shown herein.

- (30) **Foreign Application Priority Data**
Sep. 4, 2014 (KR) 30-2014-0043238
- (51) **LOC (10) Cl.** **15-02**
- (52) **U.S. Cl.**
USPC **D15/9**
- (58) **Field of Classification Search**
USPC D15/7-9; D23/231, 232, 225; 417/60, 417/235, 265, 321, 355, 358, 363, 359, 417/410.1, 415-416, 405, 900, 231, 313, 417/273, 539; 60/408, 412; 184/26-37; 415/140-147; 123/495, 509; 418/259
CPC F01D 5/14; F01D 5/12; F01D 5/04; F02B 33/40; F04D 29/42
See application file for complete search history.

DESCRIPTION

FIG. 1 is a perspective view of a compressor for vehicles according to the present design;
 FIG. 2 is a front view of the compressor for vehicles according to the present design;
 FIG. 3 is a rear view of the compressor for vehicles according to the present design;
 FIG. 4 is a left side view of the compressor for vehicles according to the present design;
 FIG. 5 is a right side view of the compressor for vehicles according to the present design;
 FIG. 6 is a plan view of the compressor for vehicles according to the present design; and,
 FIG. 7 is a bottom view of the compressor for vehicles according to the present design.
 The broken lines in FIG. 5 are included for the purpose of illustrating portions of the compressor for vehicles that form no part of the claimed design.

- (56) **References Cited**
U.S. PATENT DOCUMENTS
D440,232 S * 4/2001 Kou D15/9
D441,378 S * 5/2001 Kou D15/9

1 Claim, 7 Drawing Sheets

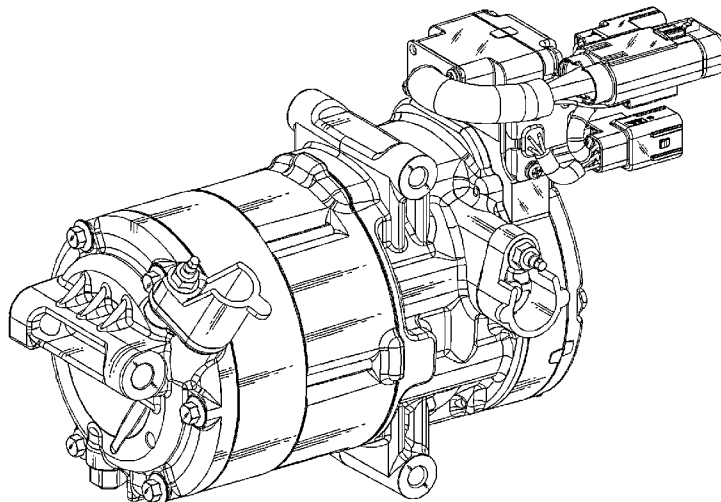

Fig. 1

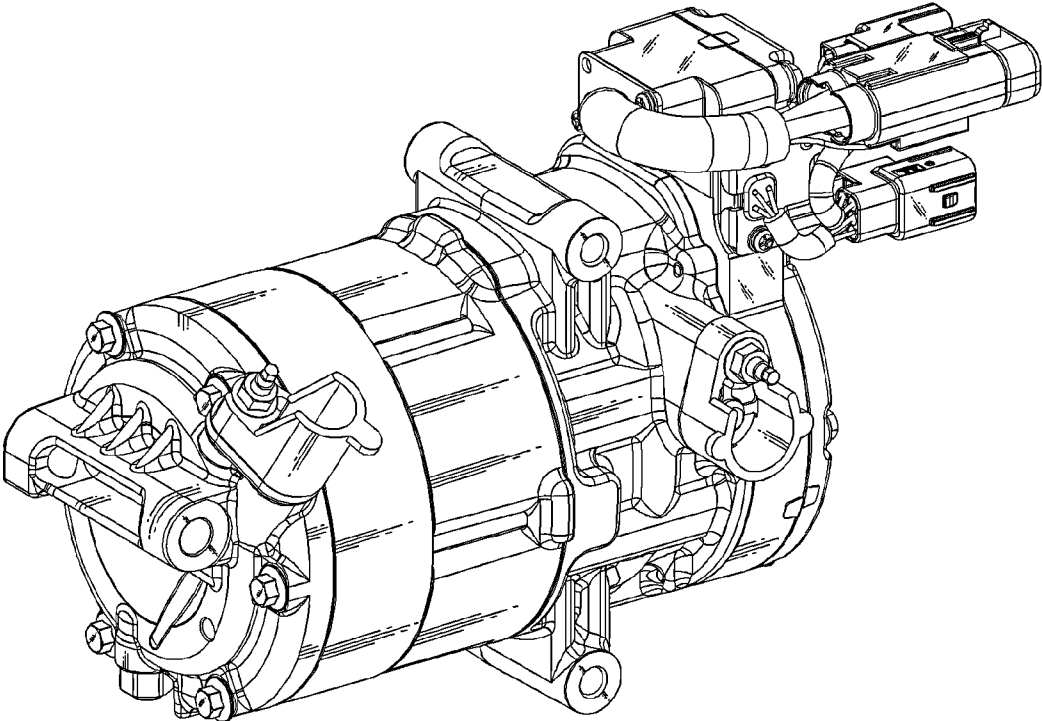

Fig. 2

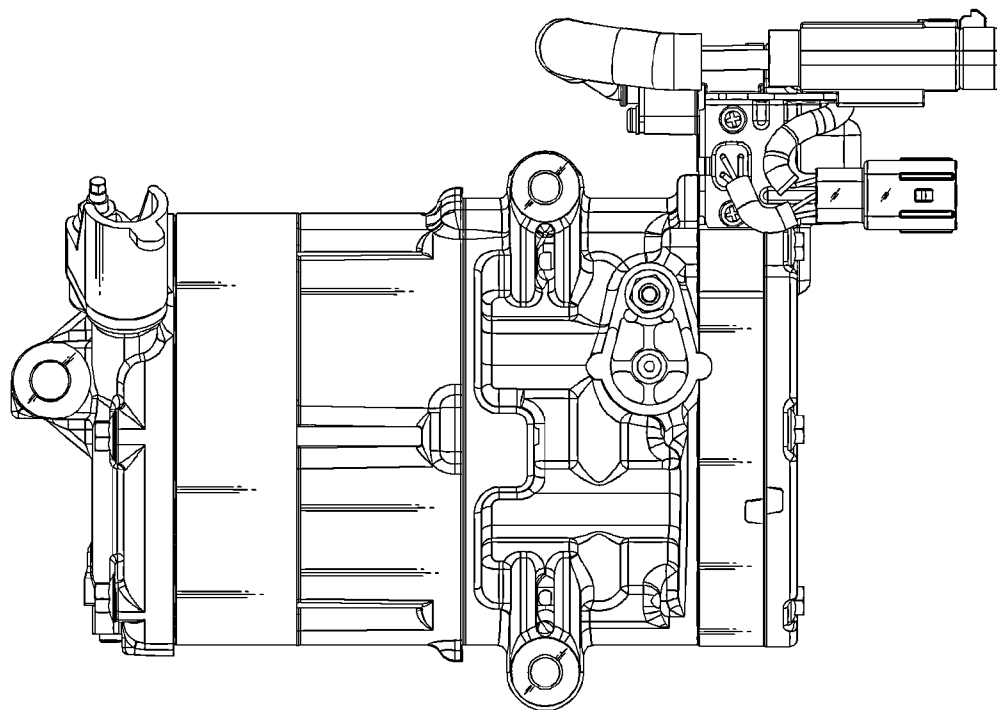

Fig. 3

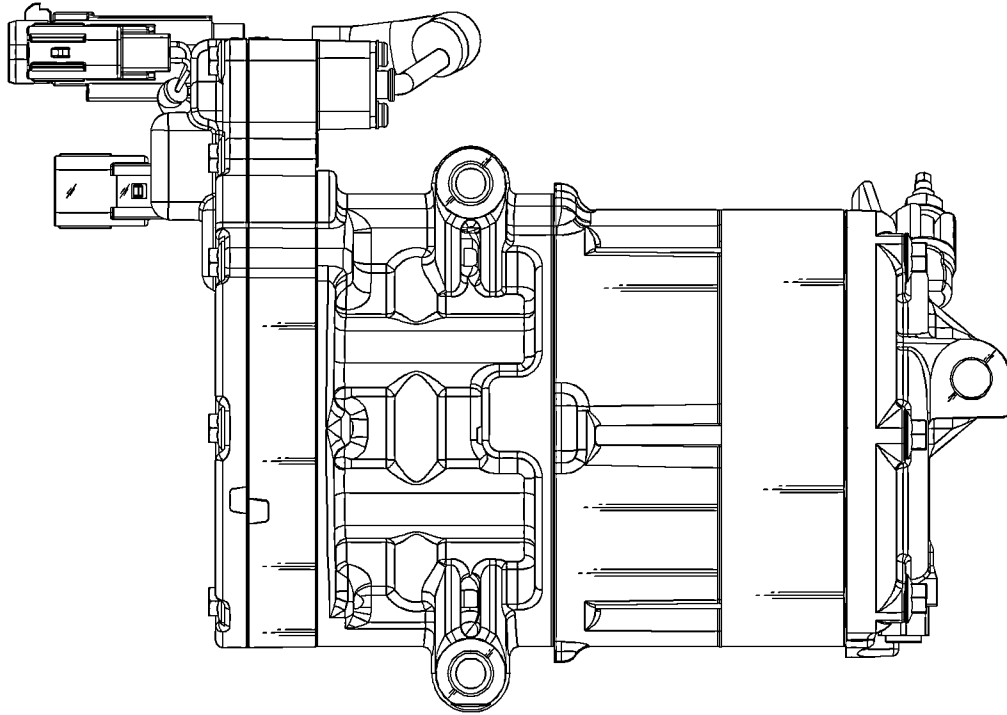

Fig. 4

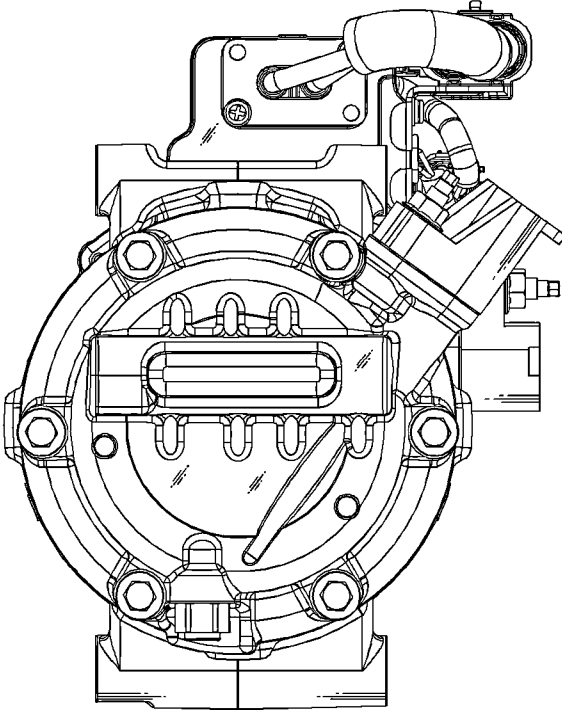

Fig. 5

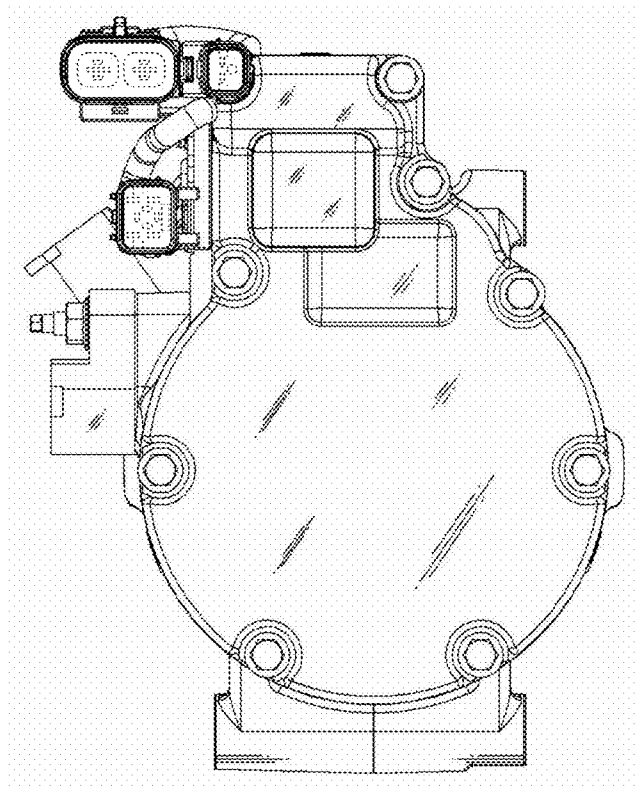

Fig. 6

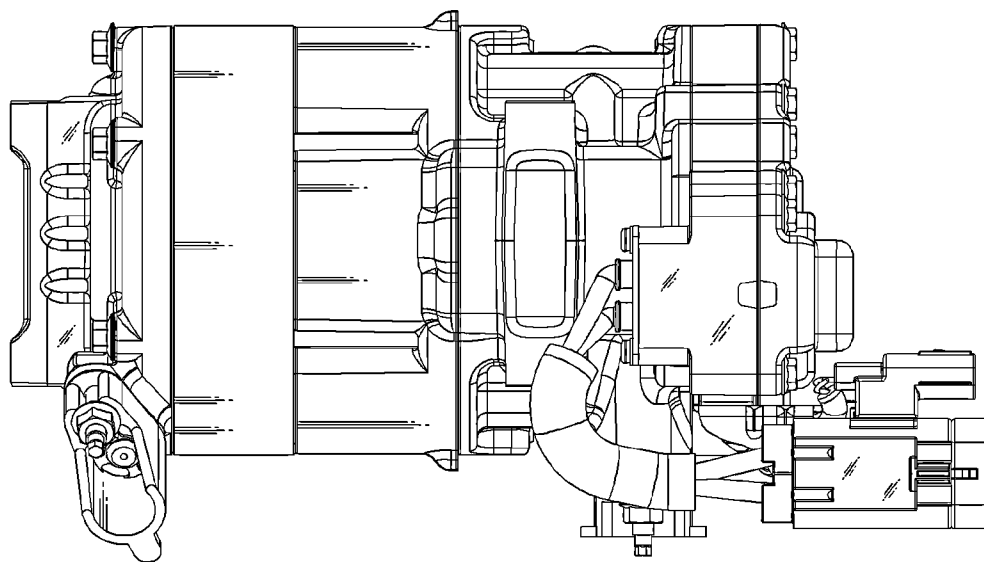

Fig. 7

