

Nov. 25, 1930.

F. MERIAN ET AL

1,782,475

PLATE GLASS POLISHING APPARATUS

Filed Aug. 6, 1925

4 Sheets-Sheet 1

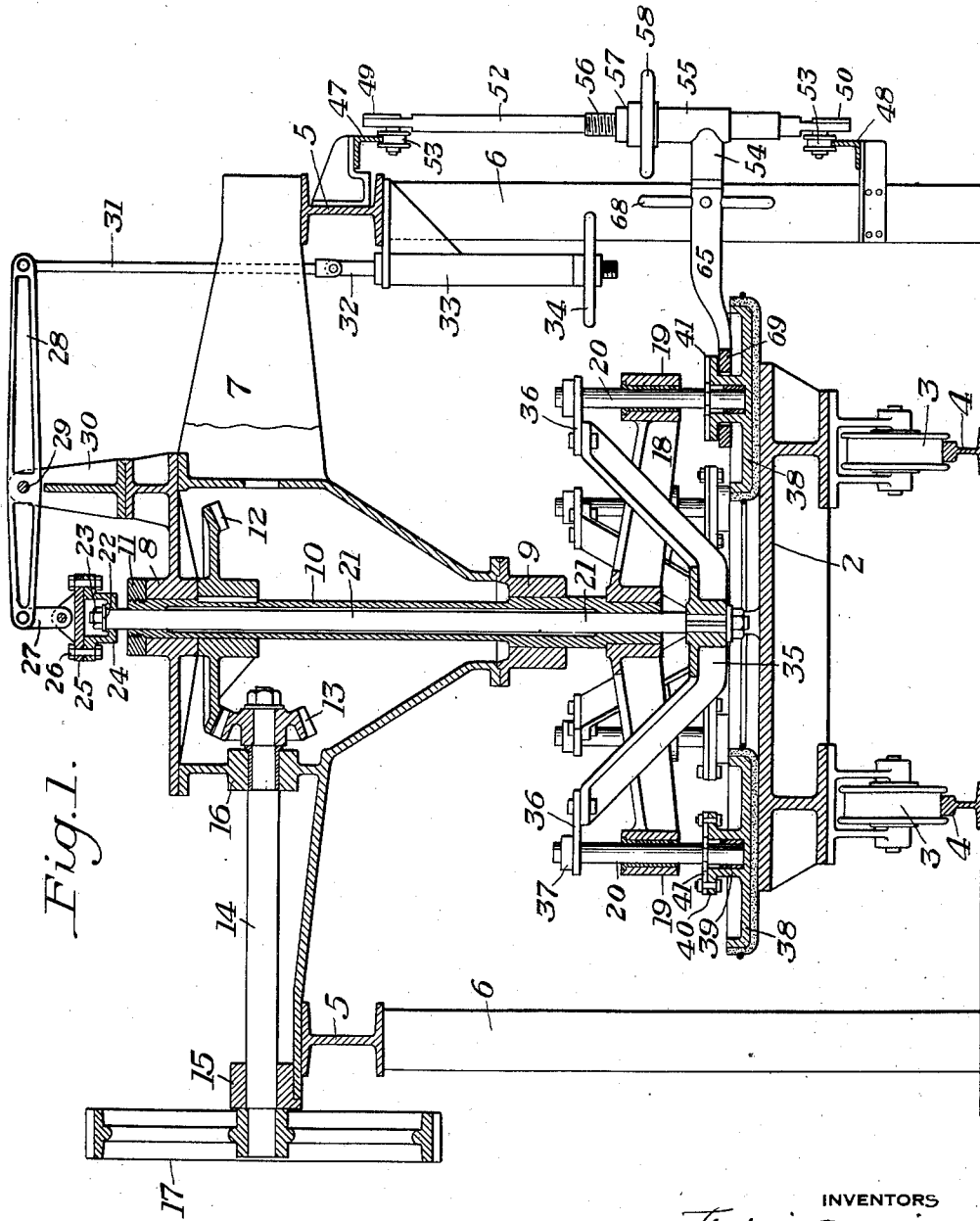

Fig. 1.

INVENTORS

Frederic Merian
James W. Crumbach
Lyons, Arthur Parnell,
Chas. Otter

Nov. 25, 1930.

F. MERIAN ET AL.

1,782,475

PLATE GLASS POLISHING APPARATUS

Filed Aug. 6, 1925

4 Sheets-Sheet 2

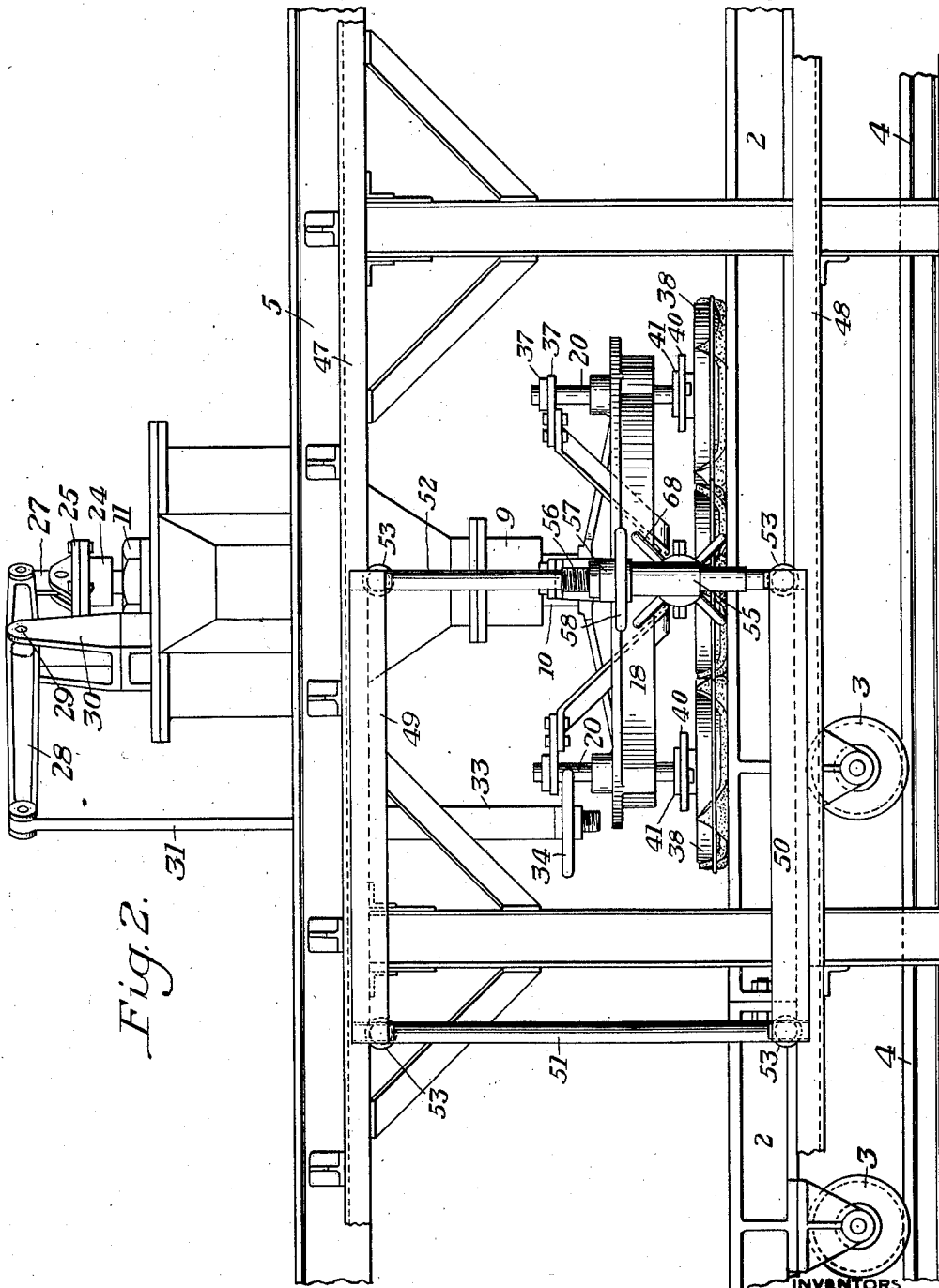

Fig. 2.

INVENTORS
Frederic Merian,
James W. Crutcher,
Lyner Aultrui Parmelee,
their Attys

Nov. 25, 1930.

F. MERIAN ET AL

1,782,475

PLATE GLASS POLISHING APPARATUS

Filed Aug. 6, 1925

4 Sheets-Sheet 3

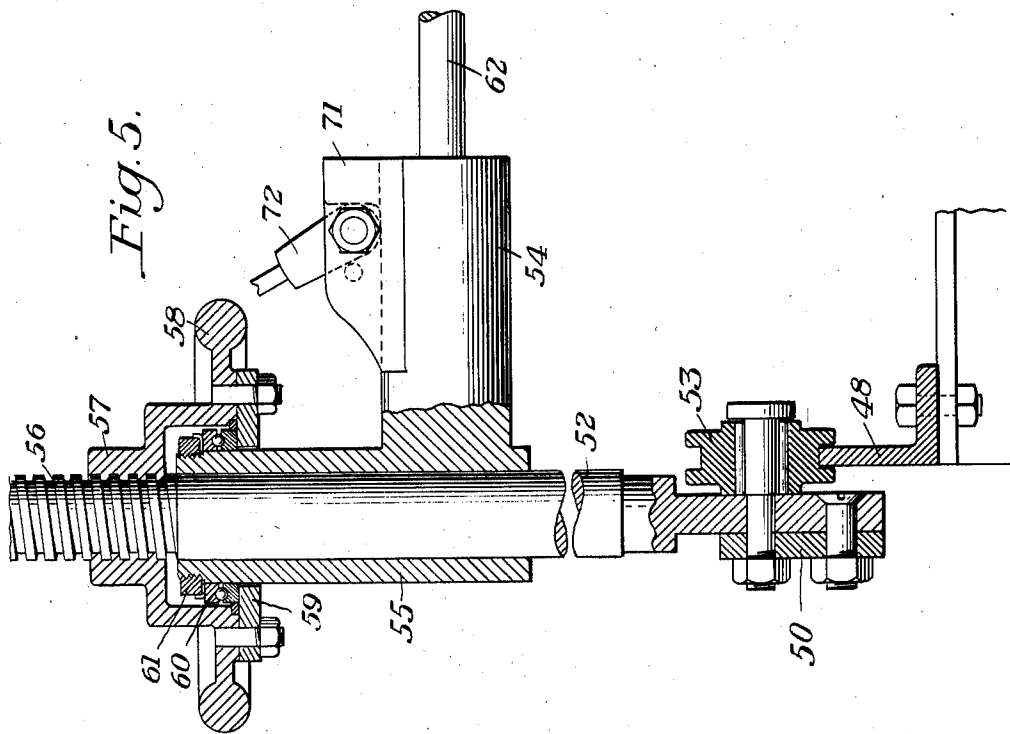

Fig. 5.

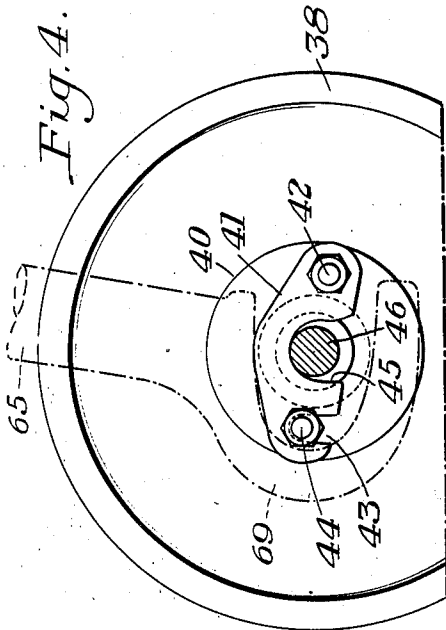

Fig. 4.

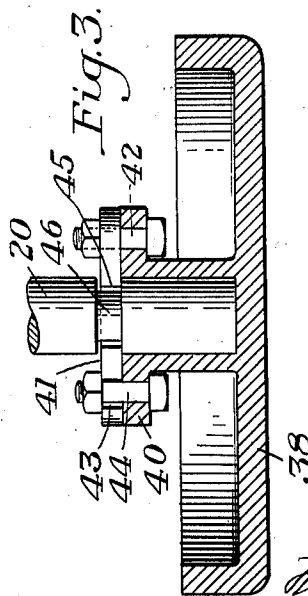

Fig. 3.

INVENTORS
Frederic Merian,
James W. Crutcher,
By James Edwin Darnelle,
their atty.

Nov. 25, 1930.

F. MERIAN ET AL

1,782,475

PLATE GLASS POLISHING APPARATUS

Filed Aug. 6, 1925

4 Sheets-Sheet 4

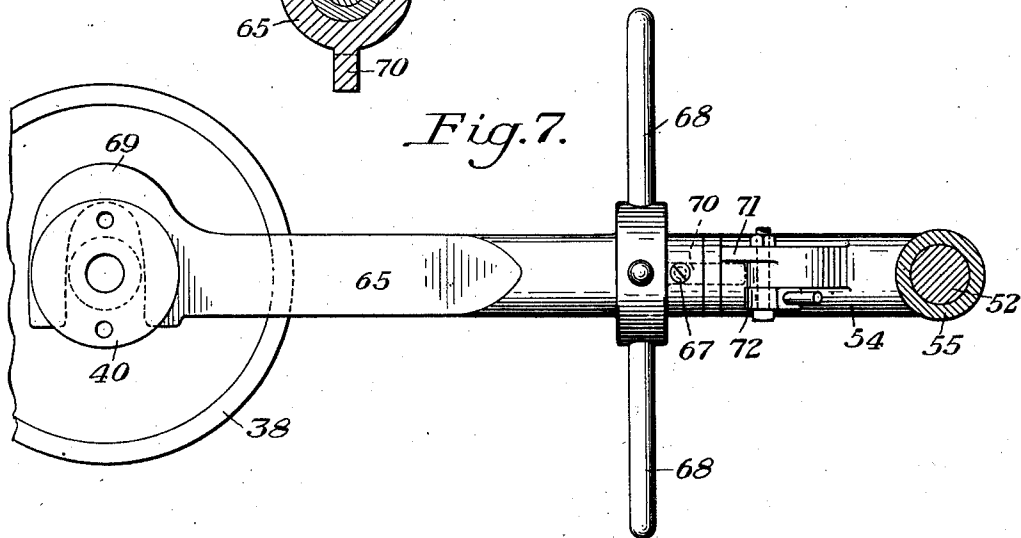
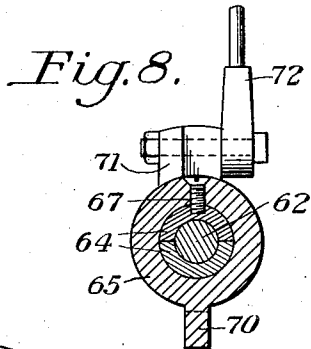
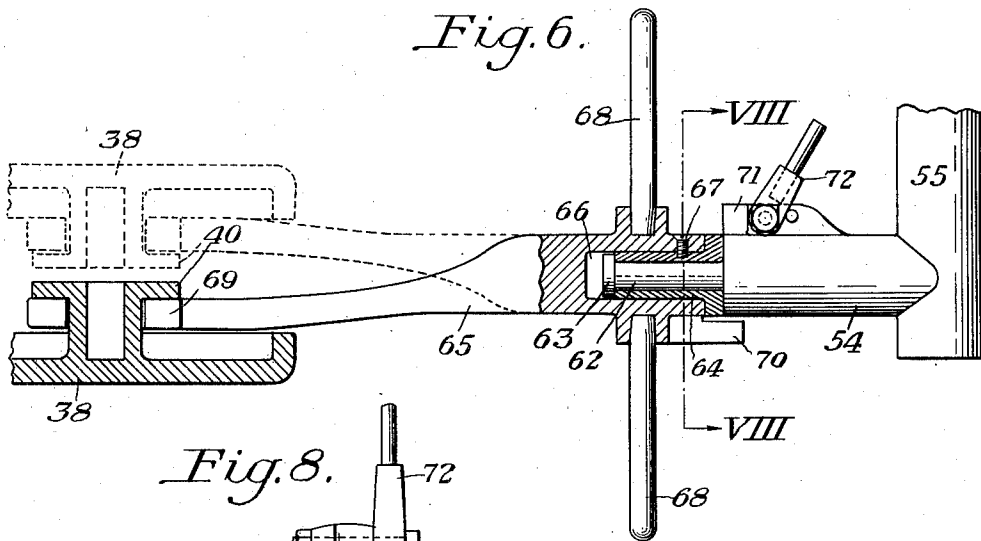

INVENTORS
*Frederic Merian,
James W. Crossbark,
By James Hillman, Attorney
-Chas. Mayo*

UNITED STATES PATENT OFFICE

FREDERIC MERIAN AND JAMES W. CRUIKSHANK, OF PITTSBURGH, PENNSYLVANIA,
ASSIGNORS, BY MESNE ASSIGNMENTS, TO PILKINGTON BROTHERS LIMITED, OF
LANCASHIRE, ENGLAND, A BRITISH COMPANY

PLATE-GLASS-POLISHING APPARATUS

Application filed August 6, 1925. Serial No. 48,530.

The present invention relates to apparatus for polishing plate glass, and particularly to apparatus for use in the continuous process of polishing in which the glass to be polished is carried beneath a series of polishers on cars or other carrier apparatus.

In the usual construction of polishing apparatus, the vertical driving shaft is either slidable in a driving gear which is splined on the shaft, or the shaft is driven through a spur gear and pinion between which there is relative vertical movement when the driving shaft is moved vertically. Either form of drive is objectionable because of the wear caused on the key in the first form of drive and the uneven wear between the teeth of the gears in the second form of drive. An object of the present invention is to provide a driving shaft having a stationary axis to which shaft the driving gear is fastened, and means for raising the polisher blocks independently of the driving shaft, thereby overcoming the objectionable features incident to the former constructions.

In the old method of polishing which was intermittent, after the polishing operation the circular polishing table was flooded with water and the blocks brought into proper condition for the next polishing operation. In the continuous process, however, to which the present invention relates, the blocks are continually working over the glass. Difficulty has been experienced in examining the bottom of these blocks and reconditioning them, as with constant use they will become clogged up and out of condition. A further object of the invention, therefore, is to provide a quick means for removing the polisher blocks for examination, for changing the same and for washing off any accumulations of rouge or foreign matter.

The invention is illustrated in the accompanying drawings, in which—

Figure 1 is a vertical transverse sectional view of a polishing machine embodying the features of the present invention;

Figure 2 is a side elevation of the apparatus shown in Figure 1, looking from the right;

Figures 3 and 4 are detail views of a polish-

er block showing the attachment of the same to a spindle;

Figure 5 is a detail sectional view of a part of the trolley and arm for changing the polisher blocks; and

Figures 6, 7 and 8 are detail views showing the construction of the trolley arm.

Referring to Figures 1 and 2, 2 designates one of the tables for supporting the plate glass, this table being supported on wheels 3 running on rails 4. The polishing machine is supported on beams 5 mounted on columns 6. The frame 7 of the machine has bearings 8 and 9 in which is journaled a vertical hollow shaft 10 provided with a collar 11 at its upper end engaging the upper bearing 8. A bevel gear 12 is keyed to the shaft 10 below the bearing 8 and meshing therewith is a driving pinion 13 carried on the end of a horizontal shaft 14 running in bearings 15 and 16. The shaft 14 has a driving pulley 17 on its outer end.

A spider or runner frame 18 is fixed to the lower end of the hollow shaft 10. This spider is provided with bosses 19 in which polisher block spindles 20 are mounted for free vertical movement in said bosses. A shaft 21 is slidably mounted in the hollow shaft 10 and is provided with a washer 22 and nut 23 at its upper end. A sleeve 24 is swivelled on the upper end of the shaft 21 beneath the washer 22 and has a member 25 attached thereto by bolts 26. The member 25 is connected by means of a link 27 to the end of a lever 28 fulcrumed at 29 intermediate its ends on a vertically extending post 30 forming part of the frame 7. The other end of the lever is connected to the upper end of a link 31, the latter being pivotally connected at its lower end to the upper end of a rod 32 sliding in a sleeve 33. The lower end portion of the rod 32 is screw-threaded and has mounted thereon a hand wheel 34 engaging the lower end of the sleeve 33.

The shaft 21 has a spider 35 rigidly connected to its lower end. This spider has upwardly extending and outwardly inclined arms arranged between the arms of the spider 18. The ends of the arms of the spider 35 have plates 36 secured thereto through which

pass the spindles 20. These spindles have collars 37 secured to their upper ends and beneath which the plates 36 engage. The polisher blocks 38 are mounted on the lower ends of the spindles 20 and are free to revolve on them. The polisher blocks are provided with hubs 39 into which the lower end portions of the spindles project. These hubs have flanges 40 on which are bolted yokes 41. By reference to Figures 4 and 5, it will be seen that each yoke 41 is pivoted at one end upon a bolt 42 and has a notch 43 in its other end to receive the bolt 44. The yoke has a notch 45 intermediate its ends to receive a reduced portion 46 of the spindle 20. With this construction the polisher block 38 can be disconnected from the spindle by loosening the nut on the bolt 44 and swinging the yoke 41 out of engagement with the spindle about the bolt 42 as a pivot.

Rails 47 and 48 are arranged at one side of the framework which supports the series of polishing machines, these rails being suitably secured to said framework, as illustrated in Figures 1 and 2. On these rails a carriage is mounted consisting of upper and lower members 49 and 50 connected at their ends by vertical posts 51 and 52. This framework carries wheels 53 which engage the tracks 47 and 48, these wheels being preferably carried by the ends of the vertical posts.

On the post 52 is swivelly mounted an arm 54. Referring to Figure 5, the arm has a sleeve portion 55 journaled on the post. This post has a screw-threaded portion 56 engaged by a nut 57 having a hand wheel 58. The nut 57 has a flange 59 bolted thereto and engaging beneath a ball bearing 60 interposed between said flange and a nut 61 mounted on the upper end of the sleeve 55. This construction permits the arm 54 to be raised or lowered and to swing freely on the post 52.

The arm 54 has an integral pin 62 projecting from the end thereof and having a head 63 at its outer end. A split sleeve 64 is mounted on the pin 62 between the end of the arm 54 and the head 63. The arm 54 has an extension 65 provided with a bore 66 in its inner end to receive the sleeve 64. This sleeve is retained in the bore 66 by means of a set screw 67. Handle bars 68 are connected to the inner end of the extension 65 for turning the same on the pin 62. The extension 65 has a yoke portion 69 at its outer end adapted to engage under the flange 40 of a polishing block 38. As illustrated in Figure 6, when the yoke has been engaged beneath the flange 40, the extension 65 is adapted to be rotated through 180°, as illustrated in dotted lines in said figure, so as to turn the polishing block upside down. When the extension 65 has been rotated through 180°, a lug 70 on its inner end engages a lug 71 on the arm 54. The parts are adapted to be retained in such position by swinging a latch 72 into position

to retain the lug 70 between the latch and the lug 71, as will be apparent by reference to Figure 7.

When it is desired to remove the polisher block, the operator raises the spider 35 by means of the hand wheel 34, acting through the lever 28 and shaft 21. He then swings the arm 54 into position to engage the yoke portion 69 beneath the flange 40 of the polisher block, the arm 54 having first been adjusted to the correct height by means of the hand wheel 58. The arm 54 is then raised until the weight of the block is carried by the yoke portion 69. The nut on the bolt 44 is then loosened and the yoke 41 swung to one side to disengage it from the spindle 20. The latter is then raised to withdraw its lower end from the hub portion of the polisher block. The arm 54 is then swung horizontally through 180° to carry the polisher block outside of the framework of the polishing machine. The block can then be removed from the arm 54 and deposited on a truck if the felt is to be renewed and another block newly covered with felt can be placed on the arm to be carried thereby in position to be attached to the spindle of the polishing machine. On the other hand, if it is desired to examine the block, clean it off and wash it, the extension 65 can be revolved by means of the handle bar 68 until the lug 70 engages the lug 71, when the parts can be locked in this position by means of the latch 72 with the felt facing upwards and in a position for cleaning and examining.

While we have shown and described a preferred embodiment of our invention, it will be understood that the invention is not limited to its disclosed embodiment, but that it may be otherwise embodied within the scope of the appended claims without departing from the spirit of the invention.

We claim:

1. In a glass surfacing machine having a supporting structure carrying runners with surfacing elements detachably secured thereto, means for removing said surfacing elements comprising a carriage movable along the supporting structure, and a vertically adjustable arm pivoted to the carriage and adapted to move into engagement with the surfacing elements to remove said surfacing elements from the runner frame.

2. In a glass surfacing machine having a supporting structure arranged over a glass supporting table and carrying surfacing elements detachable from said supporting structure, means for removing said surfacing elements from the supporting structure without disturbing the relation of the supporting structure to the table, said means including a member supported at the side of the supporting structure and adapted to be positioned to engage the surfacing elements

to support the same when detached from the supporting structure, said member being movable to carry the supported surfacing elements to an accessible position.

5 3. In a glass surfacing machine having a supporting structure carrying detachable surfacing elements, means for removing said surfacing elements when detached from the supporting structure, said means including a vertically adjustable arm movable horizontally into and out of engagement with said surfacing elements.

15 4. In a glass surfacing machine having a supporting structure carrying detachable surfacing elements, means for removing said surfacing elements when detached from the supporting structure, said means including a horizontally movable frame and a horizontally extending arm thereon, movable about a vertical axis relative to said frame, into and out of engagement with the surfacing elements.

25 5. In a glass surfacing machine having a supporting structure carrying detachable surfacing elements, means for removing said surfacing elements when detached from the supporting structure, said means including a trolley movable along the supporting structure, and a vertically adjustable arm on the trolley movable into and out of engagement with the surfacing elements.

35 6. In a glass surfacing machine having a supporting structure carrying detachable surfacing elements, means for removing and inverting the surfacing elements when detached from the supporting structure, said means including a horizontally extending arm movable into and out of engagement with the surfacing elements, and having a terminal portion for holding the detached surfacing elements, said terminal portion being rotatable 180° about its axis to invert the surfacing elements.

45 7. In a glass surfacing machine having a supporting structure carrying detachable surfacing elements, means for removing and inverting the surfacing elements when detached from the supporting structure, said means including a supporting frame movable at one side of the supporting structure, and an arm pivotally carried on the supporting frame and having a terminal portion to engage and hold the surfacing elements, said terminal portion being rotatable about a horizontal axis for inverting the supporting surfacing elements.

55 8. In a glass surfacing machine having a supporting structure carrying detachable surfacing elements, means for removing and inverting said surfacing elements when detached from the supporting structure, said means comprising a supporting frame movable at one side of the supporting structure, and an arm pivotally mounted on said frame and vertically adjustable thereon, and hav-

ing a terminal portion to support the detached supporting elements, said terminal portion being rotatable about a horizontal axis for inverting the supported elements.

9. In a glass surfacing machine having a supporting structure carrying detachable surfacing elements, means for removing said surfacing elements when detached from the supporting structure, said means comprising a trolley movable along one side of the supporting structure, an arm carried by the trolley and movable horizontally into and out of engagement with the surfacing elements, means for raising and lowering said arm, and means for rotating said arm about a horizontal axis for inverting the surfacing elements.

10. In a glass surfacing machine having a supporting structure carrying surfacing elements comprising flanged polishing discs detachable from spindles on the supporting structure, means for removing said polishing discs when detached from the spindles, comprising an arm mounted at one side of the supporting structure and having a bifurcated terminal portion for engagement beneath flanges of the discs, said arm being movable horizontally and vertically, and the terminal portion thereof being rotatable about a horizontal axis to invert the discs.

11. In a glass surfacing machine having a supporting structure carrying detachable surfacing elements, means for removing and inverting said surfacing elements when detached from the supporting structure, said means including a horizontal arm adapted to be engaged with the surfacing elements and movable to carry the detached elements to an accessible position, and said arm being rotatable about its horizontal longitudinal axis to invert the supported surfacing elements.

In testimony whereof we have hereunto set our hands.

FREDERIC MERIAN.
JAMES W. CRUIKSHANK.

110

115

120

125

130