



INTERNATIONAL APPLICATION PUBLISHED UNDER THE PATENT COOPERATION TREATY (PCT)

(51) International Patent Classification ⁶ : G09G	A2	(11) International Publication Number: WO 99/39324 (43) International Publication Date: 5 August 1999 (05.08.99)
(21) International Application Number: PCT/US99/01522 (22) International Filing Date: 26 January 1999 (26.01.99) (30) Priority Data: 09/016,657 30 January 1998 (30.01.98) US (71) Applicant: ELECTRO PLASMA, INC. [US/US]; 4400 Martin Moline Road, Millbury, OH 43447 (US). (72) Inventors: ANDERSON, Edward, C.; 1955 Beachcraft, Northwood, OH 43619 (US). OLM, David, E.; 1715 Wildwood Road, Toledo, OH 43614 (US). SCHERMERHORN, Jerry, D.; 4779 Genoa Road, Perrysburg, OH 43551 (US). (74) Agent: MEENAN, Larry, R.; MacMillan, Sobanski & Todd, LLC, One Maritime Plaza, 4th floor, 720 Water Street, Toledo, OH 43604 (US).		(81) Designated States: CN, JP, KR, MX, European patent (AT, BE, CH, CY, DE, DK, ES, FI, FR, GB, GR, IE, IT, LU, MC, NL, PT, SE). Published <i>Without international search report and to be republished upon receipt of that report.</i>
(54) Title: PLASMA DISPLAY AND METHOD OF OPERATION WITH HIGH EFFICIENCY		
(57) Abstract An improved AC plasma display panel structure and method of driving for improved efficiency. Gaseous discharges can tunnel or initiate in microchannels parallel to sustain electrodes in a frontsubstrate lowering operating voltages and allowing the use of more efficient gas mixtures. A write step applies a pulse to selected first and second sustain electrodes corresponding to cells on a row that will be turned ON, and an erase step applies a voltage to first and third electrodes corresponding to cells that are to be turned OFF. Write discharges are tunneled through microchannels.		

FOR THE PURPOSES OF INFORMATION ONLY

Codes used to identify States party to the PCT on the front pages of pamphlets publishing international applications under the PCT.

AL	Albania	ES	Spain	LS	Lesotho	SI	Slovenia
AM	Armenia	FI	Finland	LT	Lithuania	SK	Slovakia
AT	Austria	FR	France	LU	Luxembourg	SN	Senegal
AU	Australia	GA	Gabon	LV	Latvia	SZ	Swaziland
AZ	Azerbaijan	GB	United Kingdom	MC	Monaco	TD	Chad
BA	Bosnia and Herzegovina	GE	Georgia	MD	Republic of Moldova	TG	Togo
BB	Barbados	GH	Ghana	MG	Madagascar	TJ	Tajikistan
BE	Belgium	GN	Guinea	MK	The former Yugoslav Republic of Macedonia	TM	Turkmenistan
BF	Burkina Faso	GR	Greece	ML	Mali	TR	Turkey
BG	Bulgaria	HU	Hungary	MN	Mongolia	TT	Trinidad and Tobago
BJ	Benin	IE	Ireland	MR	Mauritania	UA	Ukraine
BR	Brazil	IL	Israel	MW	Malawi	UG	Uganda
BY	Belarus	IS	Iceland	MX	Mexico	US	United States of America
CA	Canada	IT	Italy	NE	Niger	UZ	Uzbekistan
CF	Central African Republic	JP	Japan	NL	Netherlands	VN	Viet Nam
CG	Congo	KE	Kenya	NO	Norway	YU	Yugoslavia
CH	Switzerland	KG	Kyrgyzstan	NZ	New Zealand	ZW	Zimbabwe
CI	Côte d'Ivoire	KP	Democratic People's Republic of Korea	PL	Poland		
CM	Cameroon	KR	Republic of Korea	PT	Portugal		
CN	China	KZ	Kazakstan	RO	Romania		
CU	Cuba	LC	Saint Lucia	RU	Russian Federation		
CZ	Czech Republic	LI	Liechtenstein	SD	Sudan		
DE	Germany	LK	Sri Lanka	SE	Sweden		
DK	Denmark	LR	Liberia	SG	Singapore		
EE	Estonia						

**PLASMA DISPLAY AND METHOD OF OPERATION WITH
HIGH EFFICIENCY**

5 **Field of Invention**

This invention relates to plasma displays and a method of operation for improved efficiency. More particularly, this invention relates to a full color, high resolution capable AC Plasma Display, commonly known as a PDP monitor, having a front or top viewing plate
10 and micro-grooves on a back-plate enclosing gaseous discharges which emit UV light and excite light emitting phosphors on the micro-groove surfaces. Such displays have application for computer screens and TV, but typically operate at low efficiency compared to CRT tubes.

15 **Background of the Invention**

A flat-panel display is an electronic display in which a large orthogonal array of display devices, such as electro-luminescent devices, AC plasma display panels, DC plasma panels and field emission displays and the like form a flat screen.

20 The basic structure of an AC Plasma Display Panel, or PDP, comprises two glass plates with a conductor pattern of electrodes on the inner surfaces of each plate and separated by a gas filled gap. The conductors are configured in an x-y matrix with horizontal electrodes and vertical column transparent electrodes deposited at right angles to each
25 other using thin-film techniques well known in the art. The electrodes of the AC-plasma panel display are covered with a thin glass dielectric layer. The glass plates are assembled together to form a sandwich with the distance between the two plates fixed by spacers. The edges of the plates are sealed and the cavity between the plates is evacuated and back-
30 filled with neon and argon or a similar gas mixture. When the gas ionizes, the dielectrics charge like small capacitors so the sum of the drive voltage

and the capacitive voltage is large enough to excite the gas contained between the glass plates and produce a glow discharge. As voltage is applied across the row and column electrodes, small light emitting pixels form a visual picture.

5 Barrier ribs are typically disposed between the foregoing insulating substrates so as to prevent cross-color and cross-pixel interference between the electrodes and increased resolution to provide a sharply defined picture. The barrier ribs provide a uniform discharge space between the glass plates by utilizing the barrier ribs height, width
10 and pattern gap to achieve a desired pixel pitch. For example, barrier ribs of plasma display panels most desirably have a configuration of about 100 μm in height and are as narrow as possible, preferably less than 20 μm in width and spaced at about 120 μm pitch. This requirement is necessary in order to achieve a color pixel pitch of 72 lines per inch, the
15 printing industry standard point of type, which is equivalent to a sub-pixel pitch of 216 lines per inch with a red, green and blue phosphor stripe color arrangement. This pattern is commonly used to achieve color output in flat panel and many cathode ray tube displays with diagonal dimensions on the order of 20 to 40 inches used for displaying graphic
20 and textual information in computer terminal equipment and television receivers.

 An alternative geometry for an AC PDP is given according to U.S. patent application serial number 08/629,723, incorporated herein by reference. In a PDP of this type, the backplate is manufactured by first
25 constructing an array of microgrooves, metalizing the recessed surfaces of the microgrooves, applying a phosphorescent material on the microgroove surfaces co-incident with the metalized surfaces, and sealing with a front plate containing a dielectrically isolated conductor array generally orthogonal to the microgroove array, i.e., metal on groove

(MOG) structure. Flat panel displays, such as AC plasma display panels (AC-PDPs) are desired to have large screens, large capacity, and the ability to display full-color images. In particular, the AC PDPs must provide more display lines and intensity levels and reliably rewrite their
5 screens without decreasing the luminance of the screens, but all at reasonable power.

It is an object of the invention to provide an improved panel structure and method and apparatus for driving an AC plasma display panel with high efficiency. Another object of the present invention is to
10 provide a method and an apparatus for driving a lateral discharge plasma display panel that is capable of displaying 256 shades of gray at lower voltages than possible with the prior art.

Summary Of The Invention

15 Briefly, according to this invention there is provided a method of operating an AC plasma flat-panel display having a hermetically sealed gas filled enclosure. The enclosure includes a top transparent substrate and a bottom substrate spaced from but in contact with top substrate. The top substrate has an array of paired top electrodes and an electron
20 emissive and insulating film covering the top electrodes but with a newly invented micro-channel under and parallel to said top electrodes. The bottom substrate has a plurality of parallel micro-grooves arranged orthogonally to the top electrodes and a bottom electrode formed of metal and deposited within each microgroove having a bottom and side-walls
25 and a phosphor material deposited on and coincident with each bottom electrode thereby forming sub-cell pairs called sub-pixels at the projected intersections of the top electrodes forming rows and microgrooves forming columns. However, the bottom substrate may be of several prior art types but advantageously of the MOG geometry as just described.

30 In general the method comprises the steps of:

applying a sustain step comprised of applying a first voltage to first electrodes of top electrode pairs and a second voltage, of opposite polarity to the first voltage, to the second electrodes paired with the first electrodes which creates discharges between sub-cell pairs which have

5 charges stored on the dielectric under corresponding top electrodes, maintaining the voltages until discharges extinguish thereby depositing charges under the top electrodes of opposite polarity

applying first terminating voltages to first top electrodes and second terminating voltages to second top electrodes as necessary to

10 sweep residual charges in gas volume, and reversing the polarities of first and second top electrodes and repeating the sequence continuously in conjunction with optional selective addressing steps which include:

applying a selective write step comprised of applying a write

15 voltage of common polarity to a preceding or co-incident sustaining voltage to a first electrode of one or more pairs of top electrodes and a common write voltage to all bottom electrodes,

applying a second write voltage, of opposite polarity to the first, to the second electrode paired with the first electrode causing discharges

20 to initiate and spread along the top substrate microchannels, and maintaining the voltages until discharges extinguish thereby depositing and storing charges on dielectric coating under the top electrodes along the entire row; and

applying a selective erase step comprised of applying an erase

25 voltage of opposite polarity to a preceding sustaining voltage to a first electrode of one pair of top electrodes and a column voltage to selected bottom electrodes, the resulting voltage of combined magnitude sufficient to cause a discharge only at sub-cell sites which have charges stored under corresponding top electrodes, and

maintaining the voltages until discharges extinguish thereby removing stored charges which prevent discharging at subsequent sustain steps.

For a MOG device the method comprises the steps of:

- 5 applying a sustain step comprised of a first voltage to first electrodes of top electrode pairs and a reference voltage to all bottom electrodes, the difference of sufficient magnitude to cause an initiating discharge to sidewalls of bottom electrodes intersected at the Paschen minimum only for sub-cells which have charges stored under
- 10 corresponding top electrodes, and
- applying a second voltage, of opposite polarity to the first voltage, to the second electrodes paired with the first electrodes which creates lateral discharges between virtual electrodes, formed by the initiating discharges to sidewalls, between sub-cells pairs at pressure gap
- 15 product values greater than the Paschen minimum,
- maintaining the voltages until discharges extinguish thereby depositing charges under the top electrodes but of opposite polarity,
- applying first terminating voltages to first top electrodes and second terminating voltages to second top electrodes as necessary to
- 20 sweep residual charges in gas volume, and
- reversing the polarities of first and second top electrodes and repeating the sequence continuously in conjunction with optional selective addressing steps comprising:
- applying a selective write step comprised of applying a write
- 25 voltage of common polarity to a preceding or co-incident sustaining voltage to a first electrode of one or more pairs of top electrodes and a selective write voltage to selected bottom electrodes, the difference of sufficient magnitude to cause a discharge to sidewalls of all bottom electrodes intersected at the Paschen minimum in conjunction with

applying a second write voltage, of opposite polarity to the first, to the second electrode paired with the first electrode causing discharges to initiate and spread along the top microchannels, and

maintaining the voltages until discharges extinguish thereby
5 depositing and storing charges on dielectric coating under the top electrodes along the entire row; and

applying a selective erase step comprised of
applying an erase voltage of opposite polarity to a preceding
sustaining voltage to a first electrode of one pair of top electrodes and a
10 column voltage to selected bottom electrodes, the resulting voltage of combined magnitude sufficient to cause a discharge to sidewalls of the selected bottom electrodes at the Paschen minimum but only at sub-cell sites which have charges stored under corresponding top electrodes, and
maintaining the voltages until discharges extinguish thereby
15 removing stored charges which prevent discharging at subsequent sustain steps.

In any case, the key element is that the tunneling of discharges through the microchannels in the top, or front viewed, substrate can with certain waveforms lower the writing voltage for addressing and the
20 maximum sustain voltage. This, in combination with a higher efficiency gas mixture and an addressing waveform to exploit it, allows a display with higher operating efficiency to be made.

Brief Description Of The Drawings

25 Further features and other objects and advantages of this invention will become clear from the following detailed description made with reference to the drawings in which:

FIG. 1 illustrates a MOG device with microchannels;

FIG. 2 illustrates an alternative structure with microchannels;

30 FIGS. 3a .3c (prior art) illustrate the formation of the discharge in

a surface discharge AC plasma display panel;

FIGS. 4a .4d illustrate the development of a discharge according to a first configuration of the present invention;

FIG. 5a .5d illustrates development of a discharge according to a
5 first configuration of the present invention;

FIG. 6 illustrates the preferred waveform used to address and sustain with the present invention;

FIG. 7 is a block diagram of the apparatus used to generate the preferred waveform;

10 FIG. 8 is a block diagram of the X driving system;

FIG. 9 is a block diagram of the Y driving system;

FIG. 10 is a block diagram of the Z driving system;

FIG. 11 is a schematic diagram of the X driving system;

FIG. 12 is a schematic diagram of the Y driving system;

15 FIG. 13 is a schematic diagram of the Z driving system;

FIG. 14 is a sample Paschen Curve a PDP showing tunneling;

and

FIG. 15 illustrates the effect of tunneling on Voltage and Efficiency with varying gas composition.

20

DESCRIPTION OF THE PREFERRED EMBODIMENTS

Referring to the drawings, wherein like reference characters represent like elements, a partial cross-sectional view of a full color display is shown by way of examples in figure 1. A front or top substrate
25 has on its interior surface display electrodes 7 which may be combined with transparent extentions 8 covered with dielectric material 9 which has applied to its surface a photoemissive layer 10. Formed into this surface are microchannels 11 running parallel to the display electrodes. The front substrate is sealed in contact with a back substrate 1 containing
30 luminescent areas 5 on the surfaces of microgrooves separated by a thin

barrier 4 and forming gas filled channels within said microgrooves. On the areas 5 are deposited phosphor material on and coincident with electrodes 2 covering the interior surfaces of the micro-grooves. Each adjacent luminescent area may contain a different phosphor color, for example, red [R], green [G], and blue [B] in a repetitive pattern. An image element is typically defined by at least three luminescent areas 5 corresponding to the above three colors. This structure we shall refer to as the MOG, for Metal On Groove, geometry.

In a prior art method shown by way of example in figure 3, a surface discharge type AC plasma display panel having a three electrode structure is shown. A plurality of parallel display electrode pairs 7 are formed on a front substrate 6 and a plurality of address electrodes 2 perpendicular to the display electrode pairs are formed on a rear substrate 1. The front substrate display electrodes are covered with dielectric material 9 which has applied to its surface a photoemissive layer 10 and the address electrodes are covered with dielectric material 3. Barrier ribs 4 are formed over the dielectric material 3 and phosphorus material 5 is deposited between the barriers. The phosphors are arranged on the substrate facing the display electrode pairs with a discharge space between the phosphor and the display electrode pairs and are excited by ultra-violet rays generated from a surface discharge between the display electrodes, thereby causing luminescence. See, for example, U.S. Patent Nos. 4,638,218; 4,737,687; and 5,661,500, incorporated herein by reference.

In FIG. 2 an alternate structure is shown. This structure results in good light output as a result of the addition of ITO to the display electrodes by passing light that would otherwise be hidden behind the electrodes. It also allows a wider discharge area that results in an increase in light but with a corresponding increase in current. This transparent

material must be applied over the normal electrode material and requires an unwanted alignment step in the forming of the front substrate material.

In a prior art driving method for the surface discharge structure with a bottom substrate substantially as shown in FIG. 2, a reset step of
5 applying a pulse of a first voltage to the paired first and second display electrodes; a write step of applying a pulse of a second voltage to the second and third electrodes corresponding to cells to be turned ON; and a sustain discharge step of applying an AC pulse of a fourth voltage to the paired first and second electrodes, wherein the pulse of the first voltage
10 being set so that it erases all cells in the display. A write step is performed in which cells of the first display line to be turned ON receive a pulse of the second voltage, cells of the second display line to be turned ON receive a pulse of the second voltage, cells of the third display line to be turned ON receive a pulse of the second voltage, etc. until all cells in
15 the display have been written.

The application of this sequence of voltages results in a surface discharge as shown in FIG. 3 wherein the parallel electrodes 7 of the front plate have been widened by the application of a transparent electrode 8 typically composed of Indium Tin Oxide (ITO). FIG. 3c
20 shows that write voltage applied to the display electrode 7 and the address electrode 2 forms a discharge 14 between the front substrate 6 and back substrate 1. The resulting discharge accumulates charges on the front substrate 6 and back substrate 1. The charges on the front substrate 6 must be large enough so that on application of the next sustain pulse, a
25 discharge will occur between the two display electrodes 7. The resulting discharge 12 forms across the narrow gap between the display electrodes as shown in FIG. 3a. FIG. 3b illustrates that as the discharge 13 progresses, it elongates to cover the whole width of the display electrodes and forms charges on both the front display electrodes and the rear

address electrodes. The light output resulting from the surface discharge can be seen in FIG 5 as it is formed by the display electrodes 7.

The sustaining and operating conditions of prior art displays are set by the gas physics relating primarily to a Paschen Curve which has the shape indicated in FIG. 14. In heretofore known prior art displays, discharges must occur on the right hand side of the Paschen Curve. That is, above the minimum and in a region where decreasing $P \times d$ (product of pressure and gap length along the Electric field vector) causes decreasing operating voltage. This is essential to the sustaining mechanism because otherwise as the discharge begins a virtual cathode and anode is established which effectively shortens the gap (d) and a discharge would self-extinguish prematurely. On the other hand, it also forces unwanted charge build-up on the dielectrics covering the address electrodes, which must be compensated for in addressing schemes. Further, this structure limits the gas mixture to low percentages of Xe in buffer gasses in order to achieve reasonable operating and address voltages.

FIG. 4 illustrates a PDP cross-section according to the present invention which provides an improved E/P (Electric field divided by Pressure of the gas) in combination with a smaller gap length d along the Electric field vector. In this case a microchannel is formed in the shape of an inverted T between the front substrate electrode pairs, however, it should be understood that microchannels of other cross-sectional shapes are possible and contemplated. In such a device, the sequence of discharging as shown in figure 4, and when combined with waveforms of the present invention, differs from the prior art and the sustaining and addressing voltages are advantageously lowered. This is illustrated in the data plots of figures 14 and 15 as the upper limit of the sustaining range with tunneling.

In another embodiment of the present invention, FIG. 5 illustrates the formation of a lateral discharge in an AC plasma display in accordance with the present invention and prior art for the MOG structure, Referring to the display electrodes 7 formed on the front substrate 6, a sustain voltage V_a is applied to the display electrodes such that an "ON" cell with wall voltage V_w will remain on when:

$$V_a + V_w > V_{fmax_1} + V_{fmax_2} \quad I$$

where V_{fmax_1} is the maximum required firing voltage for a discharge to occur from the Y display electrode to the address electrode 2 and V_{fmax_2} is the maximum required firing voltage for a discharge to occur between the Z display electrode and the address electrode as shown in FIG 4 a) for Phase I of the sustaining discharge. $V_a + V_w$ must also be less than the required firing voltage V_{fmax_3} that is necessary to begin a discharge between the display electrodes which we shall refer to as Y and Z. As these discharges develop, Phase II of the discharge begins wherein the gas ionizes and the discharge spreads forming the discharge 14 shown in FIG. 5 c) which occurs between virtual anode and cathode formed over the display electrodes during phase one, This discharge causes Phase III of the discharge wherein charges (+ and \ominus) are collected on the surface of the front substrate such that the voltage across the cell decreases and the discharge extinguishes. The discharge may be made to re-occur by reversing the applied voltage across the display electrodes and thus causing the discharge to reverse with corresponding reversal in the wall charge. This sequence of reoccurring discharges is known as sustaining.

It will be appreciated that there is no wall charge collected on the address electrode since there is no dielectric material covering these electrodes. It will be further appreciated that the discharges to the walls of a MOG structure develop at the region of the minimum on the Paschen curve during the first stage of sustaining and will occur somewhere along

the microgroove side-wall. Because such a discharge will begin to self-extinguish due to the development of a virtual cathode and anode, there is only a small amount of current that occurs between the front and back substrate and the probability of damaging the phosphor is minimized.

- 5 This is important to maintain long display life. Further, because the d of the $P \times d$ product, described above, is small the starting voltage for the MOG device is minimized automatically.

During the second phase of the lateral discharge the virtual cathode and anode formed by the first phase will then develop a
10 discharge laterally between themselves. The spacing between the electrode sustain pair on the front plate will now determine the firing voltage and path for the lateral discharge phase. This spacing can be designed relatively independently of the groove depth and display voltages and the light-output more optimally adjusted.

- 15 For example, if the electrode pair spacing is made large, the discharge appears quite long like a thread of light formed laterally along the length of the groove cavity. In this case there is sputtering primarily at the electrode positions and therefore sputtering damage is limited to only a small area of the discharge cell surface. This design is ideal for
20 low power, high resolution devices, but the efficiency tends to be rather low because one must choose a gas mixture commensurate with practical voltages, and the longer the discharge path the higher the sustaining voltage.

An examination of the relation between efficiency, gas mixture,
25 and operating voltage as plotted for illustration in FIG. 15 leads one to a design with a higher voltage gas mixture. This can be accommodated with the MOG structure more easily than the prior art because, even with high sustain voltages, addressing voltages for erasing can be kept low. However, the writing voltages can become unacceptably high, a problem

which is solved with the invention of microchannels and appropriate waveforms according to the present invention.

FIG 5 illustrates the addressing technique for the MOG structure wherein a write pulse of voltage V_{pw} is applied to one display electrode 5 7 and the address electrode 2. V_{pw} must be greater than the required firing voltage V_{fmax_1} described above. However, this voltage can be substantially lowered if a discharge in a neighboring channel can be made to tunnel through the microchannel formed along the top substrate electrodes. Such a discharge will propagate along an entire row of pixels 10 given an appropriate voltage waveform condition. A starting cell may simply be the most easily fired along the row. In this case the minimum firing voltage for the row becomes the writing voltage for the row. Otherwise, the voltage would need to be the maximum voltage for the row. Alternatively, a starting cell may be provided along the edge of the 15 active useful display matrix.

The resulting discharges cause wall charge to collect on the front substrate of V_{wa} such that $V_a + V_{pw} + V_{wa}$ is greater than $V_{fmax_1} + V_{fmax_2}$ so that the on the preceding sustain waveform transition, sustaining is initiated and the cell is turned "ON".

20 To erase a cell, the wall charge shown in FIG 4c must be reduced so that equation I described above is not met. This is accomplished by causing a discharge between one of the front display electrodes and the address electrode. In this case, the resulting discharge causes a wall charge to be placed on the front surface that is of the same polarity as that 25 of the second display electrode. For example, if the Y display electrode contains a positive wall charge and the Z display electrode has a negative wall charge, causing a discharge between the Y electrode and address electrode may be accomplished by application of a positive voltage to the Y electrode and a negative voltage to the address electrode. The result of

this discharge will be to place a negative charge over the Y electrode. Since both Y and Z now contain a negative wall charge, the wall voltage is reduced and the conditions of equation I will not be met and the cell will be extinguished.

5 FIG. 6 illustrates the waveforms of a preferred embodiment of the present invention that meets the necessary requirements for driving the MOG structure. In FIG. 6, L represents the light output from a selected cell, X is the waveform applied to the address electrode of the selected cell, Y is the voltage applied to the Y display electrode of the
10 selected cell, and Z is the Z voltage applied to the Z electrode of the selected cell. Y and Z are of equal amplitude and are of opposite polarity. As Y transitions to the low level 3, Z transitions to the high level 1 and thus a voltage is applied to the cell of amplitude V_a and this causes a previously "ON" cell to discharge resulting in a light output pulse 12. At
15 the next step, Y transitions to the high level 1, Z transitions to the low level and this results in the application of a negative voltage to the cell of amplitude V_a and the "ON" cell again discharges and creates a light output. If the previous state of the cell was OFF, the transitions of Y and Z will not be large enough to cause the OFF cell to discharge and the cell
20 will remain in the OFF condition.

Write addressing is shown in FIG. 6 as the application of a negative pulse 5 to the Y display electrode and a positive pulse 7 to the Z display electrode. The application of these pulses causes the cells on the line formed by the Y and Z electrode to discharge, aided by the tunneling
25 phenomena previously discussed, and collect wall charges on the front substrate of sufficient amplitude so that on the next transition of the Y and Z electrodes (indicated by 6 in FIG. 6), the cell again discharges and becomes "ON". In this manner, all cells on the horizontal line formed by the Y and Z electrodes will be written.

Not all cells on the addressed horizontal line should remain in the "ON" state. It therefore becomes necessary to selectively erase those cells that must be OFF. This is accomplished by the application of erase pulses 8 to the Y display electrode and erase pulses 9 to the address electrode X.

5 If the height of the Y pulse 8 is V_{w1} , a common supply can be used to generate both the write and erase pulse heights for the Y electrode resulting in a simplification of the power supply for the display. The address pulse height 9 of value V_{e1} must then be chosen so that $V_{w1} + V_{e1}$ must be greater than V_{fmax1} in order to cause a discharge between
10 the Y electrode and the address electrode X in order for the selected cell that is to be turned "OFF". The application of the erase pulse results in a wall charge of same polarity for the Y and Z electrode and the wall voltage is reduced to a level that does not satisfy equation I and the cell is extinguished.

15 Multiple horizontal lines may be written at the same time using the same pulses 5 and 7 shown in FIG. 6. In one embodiment eight lines are typically written. Eight separate erase pulses are then sequentially applied to those eight lines. Each of the erase pulses is used to extinguish unwanted cells on those eight addressed lines. This is illustrated in FIG. 6
20 where horizontal lines L1, L2, ... L8 have all cells written with pulses 5 and 7 and then the first erase pulse 8 is used to selectively erase the unwanted cells on L1, the second pulse is used to selectively erase the unwanted cells on L2, the third pulse is used to selectively erase the unwanted cells on L3, etc. until all eight lines have unwanted cells in the
25 OFF state.

FIG. 7 illustrates the block diagram of a system that is used to generate the waveforms and data necessary. The input to the system is control signals for identifying the horizontal and vertical synchronizing signals, the data for red, green, and blue information for each pixel in the

display and a clock to indicate new pixel information. The pixel data is converted to binary form and stored in a frame memory for later retrieval. The Timing Control unit synchronizes with the sync signals and controls the waveform generator. The waveform generator is responsible for

5 sending horizontal address information to the Y and Z drive circuits, and for generating signals that are used to generate the Y and Z waveforms. Horizontal lines are written in groups of eight and the waveform control unit selects which horizontal lines make up the selected set. The selected group are bulk written and then the those lines are selectively erased.

10 The Data Transform block selects information from the frame buffer based on the selected horizontal line to be erased and determined by, for example, which bit in the grayscale value of eight bits is to be used for selecting the erase pattern. Thus the Data Transform block is responsible for manipulating the frame buffer data so that desired

15 information can be properly displayed on the plasma screen.

FIG. 8 illustrates the detailed block diagram for the address electrode (X) drive circuit. The Pulse Generator selects one of three levels to apply to the driver circuits. The V_{xw} level is used to generate the pulse height of the erase pulses for selected cells, the ground levels is used for unselected cells, and the V_{xm} level is used when no erase pulses

20 are being generated during the normal sustain time. Energy recovery circuits are used to increase efficiency when driving the capacitance of the address electrodes and is used for both the address pulse voltages (V_{xw}) and the V_{xm} level. Data to the X drive circuits is determined by

25 the Data Transform block shown in FIG. 7.

FIG. 9 illustrates the detailed block diagram for the Y display electrode drive circuit. The Y Sustain block generates the sustaining waveform 2 shown in FIG. 6. The controls for the timing of the waveform is determined by the Waveform Control block of FIG. 7. The

Y Sustain Block selects between the sustain voltage V_a and the two intermediate levels V_{ym1} and V_{ym2} . V_{ym2} is the level from which erase pulses are applied. Energy recovery circuits are used to increase efficiency when driving the capacitance of the address electrodes and is used for both the sustain voltage (V_a) and the V_{ym} levels. Erase and write address pulses are generated by the Y Pulse control block. The same pulse height is used for both erase and write pulses. The Y driver circuit chooses lines to write and erase based on Y data from the Waveform Control block. The data is used to apply or not apply the erase and write pulses to each of the horizontal lines in the display.

FIG. 10 illustrates the detailed block diagram for the Z display electrode drive circuit. The Z Sustain block generates the sustaining waveform 6 shown in FIG. 6. The controls for the timing of the waveform is determined by the Waveform Control block of FIG. 7. The Z Sustain Block selects between the sustain voltage V_a and the two intermediate levels V_{zm1} and V_{zm2} . V_{zm2} is the level from which erase pulses are applied. Energy recovery circuits are used to increase efficiency when driving the capacitance of the address electrodes and is used for both the sustain voltage (V_a) and the V_{zm} levels. Write address pulses are generated by the Z Pulse control block. The Z driver circuit chooses lines to write based on Z data from the Waveform Control block. The data is used to apply or not apply the write pulses to each of the horizontal lines in the display. It will be appreciated that since the Z and Y block diagrams are so closely related, the same circuitry can be used for both the Z and Y electrodes. This results in a savings of both design, assembly, and circuit costs.

FIG. 11 schematically illustrates a typical circuit for generating the required waveform for the (X) electrodes. Switches SW1, SW2 and SW3 control the voltage that will be applied to the driver. The two

switches inside the driver device select either the applied voltage (when the upper switch is ON, lower switch is OFF) or the common level ground (when the lower switch is ON, upper switch is OFF). The driver switches are controlled by the data bits loaded into the driver circuit by the Data Transform block shown in FIG. 7. SW1 of FIG. 11 is closed and SW2 and SW3 are open whenever the address electrode is to be pulsed with voltage VAX. SW2 is closed and SW1 and SW3 are open whenever there is only sustain activity and X is held at the medium voltage Vxm. SW3 is closed and SW1 and SW2 are open whenever the address electrode is to be at the ground level. This occurs between the address erase pulses. Energy recovery is performed by switches SW4 and SW5. SW4 is closed whenever the applied voltage is to transition from ground to VAX or from Vxa to ground. On the transition from Vxa to ground, the capacitor is charged through the inductor L1. On the transition from ground to Vxa, the capacitor is discharged through the inductor L1. Thus the capacitor average voltage will be 1/2 Vxa. Energy recovery for the Vxm levels is accomplished by SW5. SW5 is closed whenever the applied voltage is to transition from ground to Vxm or from Vxm to ground. On the transition from Vxm to ground, the capacitor is charged through the inductor L1. On the transition from ground to Vxm, the capacitor is discharged through the inductor L1. Thus the capacitor average voltage will be 1/2 Vxm. It is important to have only one switch closed at any given time. SW4 and SW5 are used for the transitions and SW1, SW2, and SW3 are used to clamp the voltages at their corresponding levels.

FIG. 12 schematically illustrates a typical circuit for generating the required waveform for the Y display electrode. Switches SW1, SW2, and SW3 control the voltage that will be applied to the Y driver. The two switches inside the driver device select either the applied voltage (when

the upper switch is ON, lower switch is OFF) or the common level ground (when the lower switch is ON, upper switch is OFF). The driver switches are controlled by the data bits loaded into the driver circuit by the Waveform Control block shown in FIG. 7. SW1 of FIG. 12 is closed and SW2, SW3, and SW4 are open whenever the display electrode is to be pulsed with the sustaining voltage V_{ya} . SW2 is closed and SW1, SW3 and SW4 are open whenever the sustain waveform is to be held at intermediate voltage V_{ym1} . SW3 is closed and SW1, SW2, and SW4 are open whenever the display electrode is to be at the second intermediate level V_{ym2} . This occurs during the address erase pulses. SW4 is closed and SW1, SW2, and SW3 are open whenever the display electrode is to be at the ground level. Switches SW5 and SW6 perform energy recovery. SW5 is closed whenever the applied voltage is to transition from V_{ym1} to V_{ya} or from V_{ya} to V_{ym1} . On the transition from V_{ya} to V_{ym1} , the capacitor is charged through the inductor L1. On the transition from V_{ym1} to V_{ya} , the capacitor is discharged through the inductor L1. Thus the capacitor average voltage will be $1/2 (V_{ya} + V_{ym1})$. Energy recovery for the V_{ym2} levels is accomplished by SW6. SW6 is closed whenever the applied voltage is to transition from ground to V_{ym2} or from V_{ym2} to ground. On the transition from V_{xm} to ground, the capacitor is charged through the inductor L1. On the transition from ground to V_{xm} , the capacitor is discharged through the inductor L1. Thus the capacitor average voltage will be $1/2 V_{xm2}$. It is important to have only one switch closed at any given time. SW4 and SW5 are used for the transitions and SW1, SW2, and SW3 are used to clamp the voltages at their corresponding levels.

FIG. 13 schematically illustrates a typical circuit for generating the required waveform for the Z display electrode. Switches SW1, SW2, and SW3 control the voltage that will be applied to the Z driver. The two

switches inside the driver device select either the applied voltage (when the upper switch is ON, lower switch is OFF) or the common level ground (when the lower switch is ON, upper switch is OFF). The driver switches are controlled by the data bits loaded into the driver circuit by the Waveform Control block shown in FIG. 7. SW1 of FIG. 13 is closed and SW2, SW3, and SW4 are open whenever the display electrode is to be pulsed with the sustaining voltage V_{za} . SW2 is closed and SW1, SW3 and SW4 are open whenever the sustain waveform is to be held at intermediate voltage V_{zml} . SW3 is closed and SW1, SW2, and SW4 are open whenever the display electrode is to be at the second intermediate level V_{zm2} . This occurs during the address erase pulses. SW4 is closed and SW1, SW2, and SW3 are open whenever the display electrode is to be at the ground level. Switches SW5 and SW6 perform energy recovery. Energy recovery for the Z display electrode is similar to that described above for the Y display electrode. It is important to have only one switch closed at any given time. SW4 and SW5 are used for the transitions and SW1, SW2, and SW3 are used to clamp the voltages at their corresponding levels.

The patents and documents referenced herein are hereby incorporated by reference in their entirety.

Having described presently preferred embodiments of the present invention, it is to be understood that it may be otherwise embodied within the scope of the appended claims.

What is claimed is:

1. A method of operating an AC plasma flat-panel display comprising a hermetically sealed gas filled enclosure, the enclosure including a top transparent substrate having an array of paired top electrodes, an insulating film covering the top electrodes with microchannels parallel to the electrodes, and an electron emissive surface; a bottom substrate in contact with the top substrate, the bottom substrate having a plurality of parallel micro-grooves arranged orthogonally to the top electrodes and forming gas filled cavities; a bottom electrode formed of metal and deposited within each micro-groove including bottom and side-walls; and a phosphor material deposited on and coincident with each bottom electrode thereby forming sub-cell pairs called sub-pixels at the projected intersections of top electrodes forming rows and microgrooves forming columns which are connected by said microchannels formed on the front substrate, wherein the method comprises the steps of:

applying a sustain step comprised of a first voltage to first electrodes of top electrode pairs and a reference voltage to all bottom electrodes, the difference of sufficient magnitude to cause an initiating discharge to sidewalls of bottom electrodes intersected at the Paschen minimum only for sub-cells which have charges stored under corresponding top electrodes, and

applying a second voltage, of opposite polarity to the first voltage, to the second electrodes paired with the first electrodes which creates lateral discharges between virtual electrodes, formed by the initiating discharges to sidewalls, between sub-cells pairs at pressure gap product values greater than the Paschen minimum,

maintaining the voltages until discharges extinguish thereby depositing charges under the top electrodes but of opposite polarity,

applying first terminating voltages to first top electrodes and second terminating voltages to second top electrodes as necessary to sweep residual charges in gas volume, and

reversing the polarities of first and second top electrodes and
5 repeating the sequence continuously in conjunction with optional selective addressing steps comprising:

applying a selective write step comprised of applying a write voltage of common polarity to a preceding or co-incident sustaining voltage to a first electrode of one or more pairs of top electrodes and a
10 selective write voltage to selected bottom electrodes, the difference of sufficient magnitude to cause a discharge to sidewalls of all bottom electrodes intersected at the Paschen minimum in conjunction with applying a second write voltage, of opposite polarity to the first, to the second electrode paired with the first electrode causing discharges to
15 initiate and spread along the top microchannels, and

maintaining the voltages until discharges extinguish thereby depositing and storing charges on dielectric coating under the top electrodes along the entire row; and

applying a selective erase step comprised of
20 applying an erase voltage of opposite polarity to a preceding sustaining voltage to a first electrode of one pair of top electrodes and a column voltage to selected bottom electrodes, the resulting voltage of combined magnitude sufficient to cause a discharge to sidewalls of the selected bottom electrodes at the Paschen minimum but only at sub-cell
25 sites which have charges stored under corresponding top electrodes, and
maintaining the voltages until discharges extinguish thereby removing stored charges which prevent discharging at subsequent sustain steps.

2. The method of claim 1 wherein all first and second voltages and

terminating voltages on paired top substrate electrodes are equal and opposite.

3. The method of claim 1 wherein the write voltage is of negative
5 polarity.

4. The method of claim 1 wherein the erase voltage is of negative polarity.

10 5. The method of claim 1 wherein the column voltage is of positive polarity.

6. The method according to 1 wherein the column voltage is ground referenced.

15

7. The method of claim 2 where the average voltage on the top substrate electrodes is biased to be near ground thereby minimizing voltages between all electrodes.

20 8. The method of claim 1 wherein a bit image, or one bit per pixel, is written into the display successively but not required sequentially by constructing a sequence of sustain steps or cycles according to the following manner:

a sustain cycle is performed with a write step consisting of a
25 group of rows selected and written to "on" and a selective erase step consisting of a number of erase pulses corresponding to the number in the group, addressed sequentially but within the same sustain cycle in which cells to be "off" are erased and those to be "on" left unaffected, thereafter, a second cycle is performed with a second group of rows in a like manner,
30 and

sequential cycles are performed until all possible groups have been addressed and the display updated to the new bit image

9. The AC PDP of claim 1 where the first and second voltages are in the range of 150 to 350 volts and the write and erase voltages are between 40 to 100 volts.

5

10. The AC PDP of claim 1 where the maintain time for sustaining voltages is from 2 to 5 micro-seconds, the time for erasing is 0.5 to 1 microsecond, and the time for writing is on the order of 2 to 5 microseconds.

10

11. A method of operating an AC plasma flat-panel display comprising a hermetically sealed gas filled enclosure, the enclosure including a top transparent substrate having an array of paired top electrodes, an insulating film covering the top electrodes with
15 microchannels parallel to the electrodes, and an electron emissive surface; a bottom substrate in contact with the top substrate, the bottom substrate having a plurality of parallel microgrooves arranged orthogonally to the top electrodes forming gas filled cavities; a bottom electrode formed of metal on the surface of or under said microgrooves;
20 and a phosphor material deposited within the microgrooves and over bottom electrodes thereby forming sub-cell pairs called sub-pixels at the projected intersections of top electrodes forming rows and bottom electrodes forming columns which are connected by said microchannels formed on the front substrate, wherein the method comprises the steps of:
25 applying a sustain step comprised of applying a first voltage to first electrodes of top electrode pairs and a second voltage, of opposite polarity to the first voltage, to the second electrodes paired with the first electrodes which creates discharges between sub-cell pairs which have charges stored on the dielectric under corresponding top electrodes,

maintaining the voltages until discharges extinguish thereby
depositing charges under the top electrodes of opposite polarity

applying first terminating voltages to first top electrodes and
second terminating voltages to second top electrodes as necessary to
5 sweep residual charges in gas volume, and

reversing the polarities of first and second top electrodes and
repeating the sequence continuously in conjunction with optional
selective addressing steps which include:

applying a selective write step comprised of applying a write
10 voltage of common polarity to a preceding or co-incident sustaining
voltage to a first electrode of one or more pairs of top electrodes and a
common write voltage to all bottom electrodes,

applying a second write voltage, of opposite polarity to the first,
to the second electrode paired with the first electrode causing discharges
15 to initiate and spread along the top substrate microchannels, and

maintaining the voltages until discharges extinguish thereby
depositing and storing charges on dielectric coating under the top
electrodes along the entire row; and

applying a selective erase step comprised of applying an erase
20 voltage of opposite polarity to a preceding sustaining voltage to a first
electrode of one pair of top electrodes and a column voltage to selected
bottom electrodes, the resulting voltage of combined magnitude sufficient
to cause a discharge only at sub-cell sites which have charges stored
under corresponding top electrodes, and

25 maintaining the voltages until discharges extinguish thereby
removing stored charges which prevent discharging at subsequent sustain
steps.

12. The method of claim 11 wherein all first and second voltages and

terminating voltages on paired top substrate electrodes are equal and opposite.

13. The method of claim 11 wherein the write voltage is of negative
5 polarity.

14. The method of claim 11 wherein the erase voltage is of negative polarity.

10 15. The method of claim 11 wherein the column voltage is of positive polarity.

16. The method according to 11 wherein the column voltage is ground referenced.

15

17. The method of claim 12 where the average voltage on the top substrate electrodes is biased to be near ground thereby minimizing voltages between all electrodes.

20 18. The method of claim 11 wherein a bit image, or one bit per pixel, is written into the display successively but not required sequentially by constructing a sequence of sustain steps or cycles according to the following manner:

25 a sustain cycle is performed with a write step consisting of a group of rows selected and written to "on" and a selective erase step consisting of a number of erase pulses corresponding to the number in the group, addressed sequentially but within the same sustain cycle in which cells to be "off" are erased and those to be "on" left unaffected, thereafter, a second cycle is performed with a second group of rows in a like manner,

and sequential cycles are performed until all possible groups have been addressed and the display updated to the new bit image.

19. The AC PDP of claim 11 where the first and second voltages are
5 in the range of 150 to 350 volts and the write and erase voltages are between 40 to 100 volts.

20. The AC PDP of claim II where the maintain time for sustaining
10 voltages is from 2 to 5 micro-seconds, the time for erasing is 0.5 to 1 microsecond, and the time for writing is on the order of 2 to 5 microseconds.

21. An AC Plasma Display Panel comprising:
a hermetically sealed gas filled enclosure, the enclosure including
15 a top transparent substrate having an array of paired top substrate electrodes, an insulating film covering the top substrate electrodes with microchannels formed parallel to the electrodes, and an electron emissive surface coating;
a bottom substrate in contact with the top substrate, the bottom
20 substrate having a plurality of parallel microgrooves arranged orthogonally to the top substrate electrodes forming isolated cavities which are gas filled;
a plurality of bottom substrate electrodes formed of metal on the surface of or under each microgroove; and
25 a phosphor material deposited on the microgroove surfaces and over bottom substrate electrodes thereby forming sub-cell pairs called sub-pixels at the projected intersections of top electrodes forming rows and bottom electrodes forming columns which are connected by said microchannels formed on the front substrate;

22. An apparatus for operating AC plasma display comprising:
a plasma display panel according to claim 21;
a first circuit connected to each first of paired top substrate
5 electrodes for generating a common multi level sustain waveform with a
selective negative addressing pulse for each electrode;
a second circuit connected to each second of paired top substrate
electrodes for generating a common multilevel sustain waveform of
opposite polarization and amplitude from the first with a selective
10 positive addressing pulse for each electrode;
a third circuit connected to each electrode on bottom substrate for
generating a common multi level sustain waveform with a selective
positive addressing pulse for each electrode;
an input converter, frame buffer, and data transform circuit with
15 external interface configured to an industry standard data source capable
of transferring row data in parallel to the third circuit;
a waveform and waveform timing control circuit interconnected
with the first four circuits and determinant of timing and control of the
sustaining circuits and addressing pulses so as to cause address pulses to
20 tunnel through microchannels during addressing thereby lowering the
address voltage; and
a power circuit capable of supplying necessary power to the first
five circuits, the power being converted from an industry standard power
source.
25
23. The AC PDP of claim 21 wherein the microchannels are between
4 and 15 microns deep and 50 to 100 microns wide.
24. The AC PDP of claim 21 wherein the microchanelns are 4 to 15

microns wide and 50 to 100 microns deep and extend into the substrate beyond insulating film.

25. The AC PDP of claim 21 wherein the microchannel has an "L" or
5 inverted "T" cross-section and may extend into the substrate beyond insulating film.

26. The AC PDP of claim 22 where the first and second voltages are
10 in the range of 150 to 350 volts and the write and erase voltages are between 40 to 100 volts.

27. The AC PDP of claim 22 where the maintain time for sustaining
15 voltages is from 2 to 5 micro-seconds, the time for erasing is 0.5 to 1 microsecond, and the time for writing is on the order of 2 to 5 microseconds.

28. The AC PDP of claim 21 wherein the gas fill is of Xenon in a
20 base gas ranging from 4% to 100% at a pressure of up to 600 torr.

29. The AC PDP of claim 21 wherein the gas fill is of Xenon in Neon
ranging from 4% to 100% at a pressure of up to 600 torr.

30. The AC PDP of claim 21 wherein the gas fill is of Xenon in equal
25 parts of Neon and Helium ranging from 4% to 100% at a pressure ranging between 300 and 600 torr.

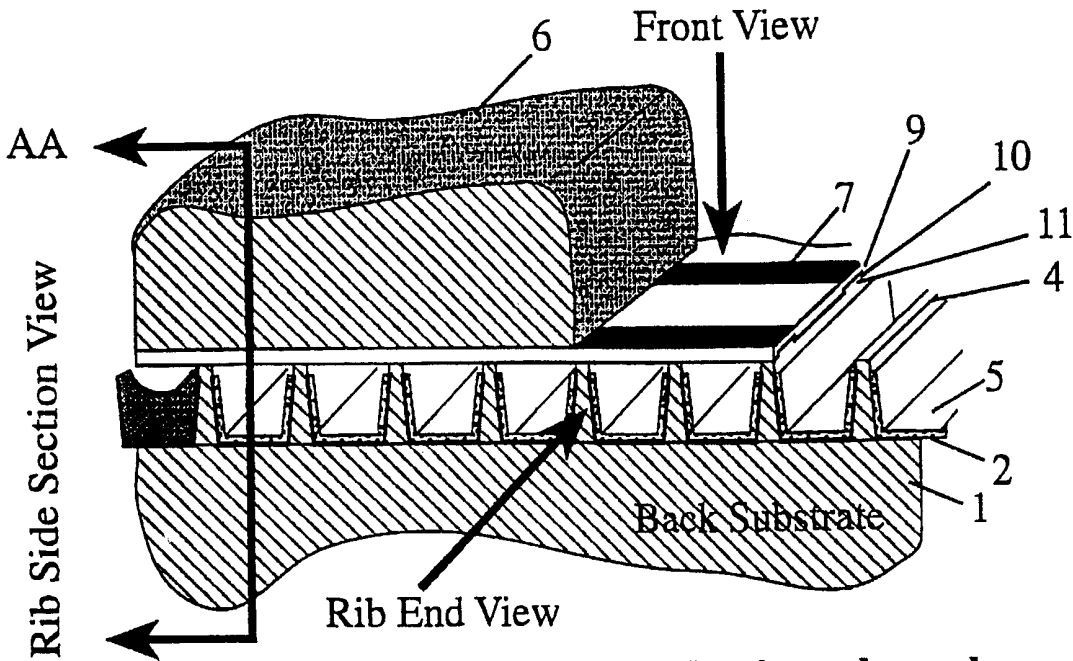

Fig. 1 MOG PDP device with micro-channels

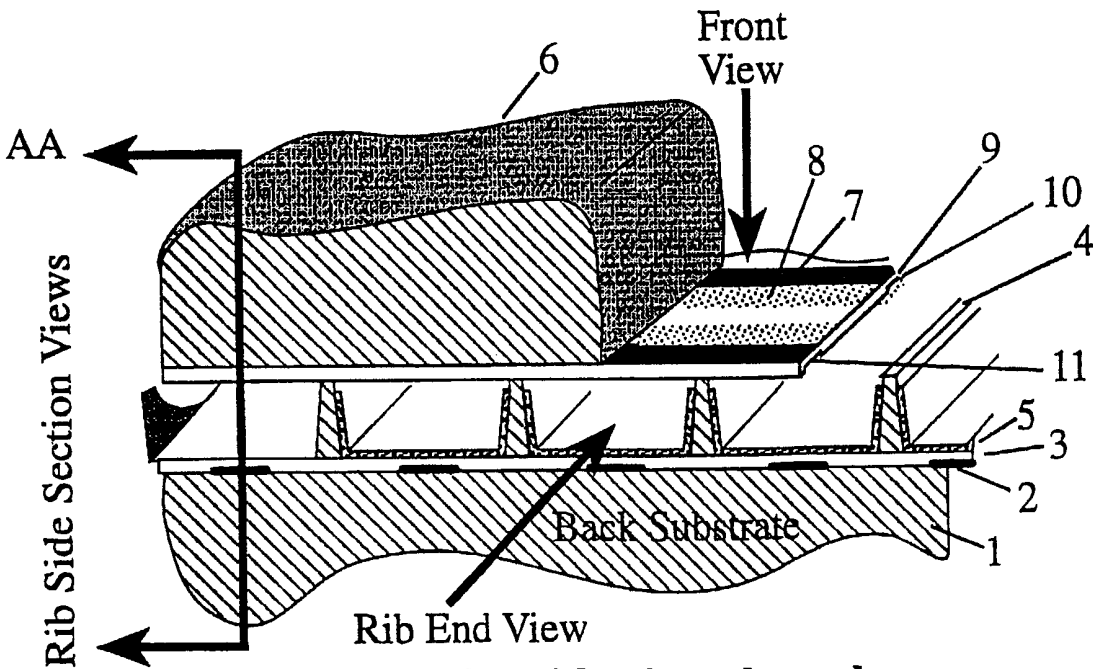

Fig. 2 PDP device with micro-channels

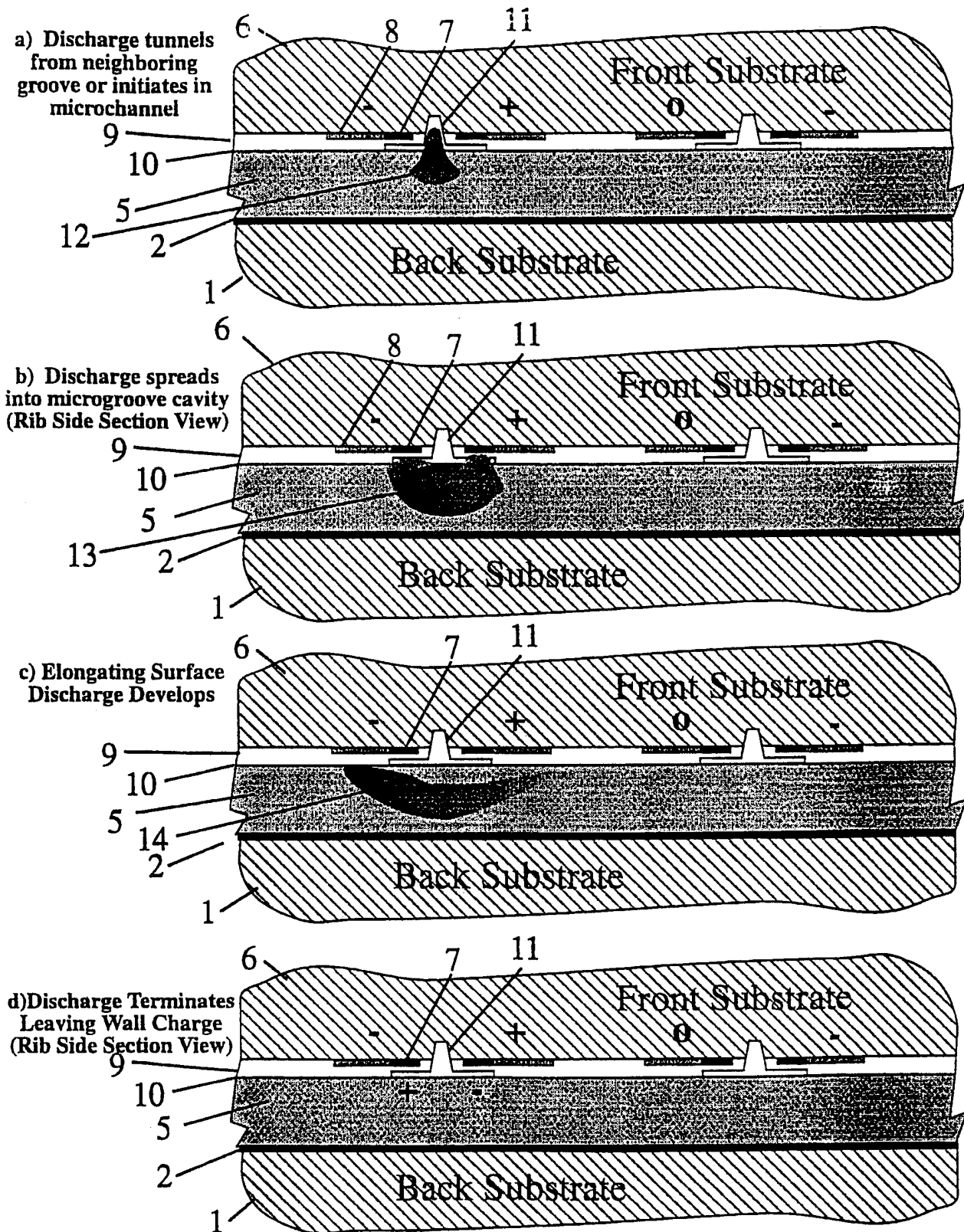

Fig. 4 Voltage Lowering Arrangement For High Efficiency

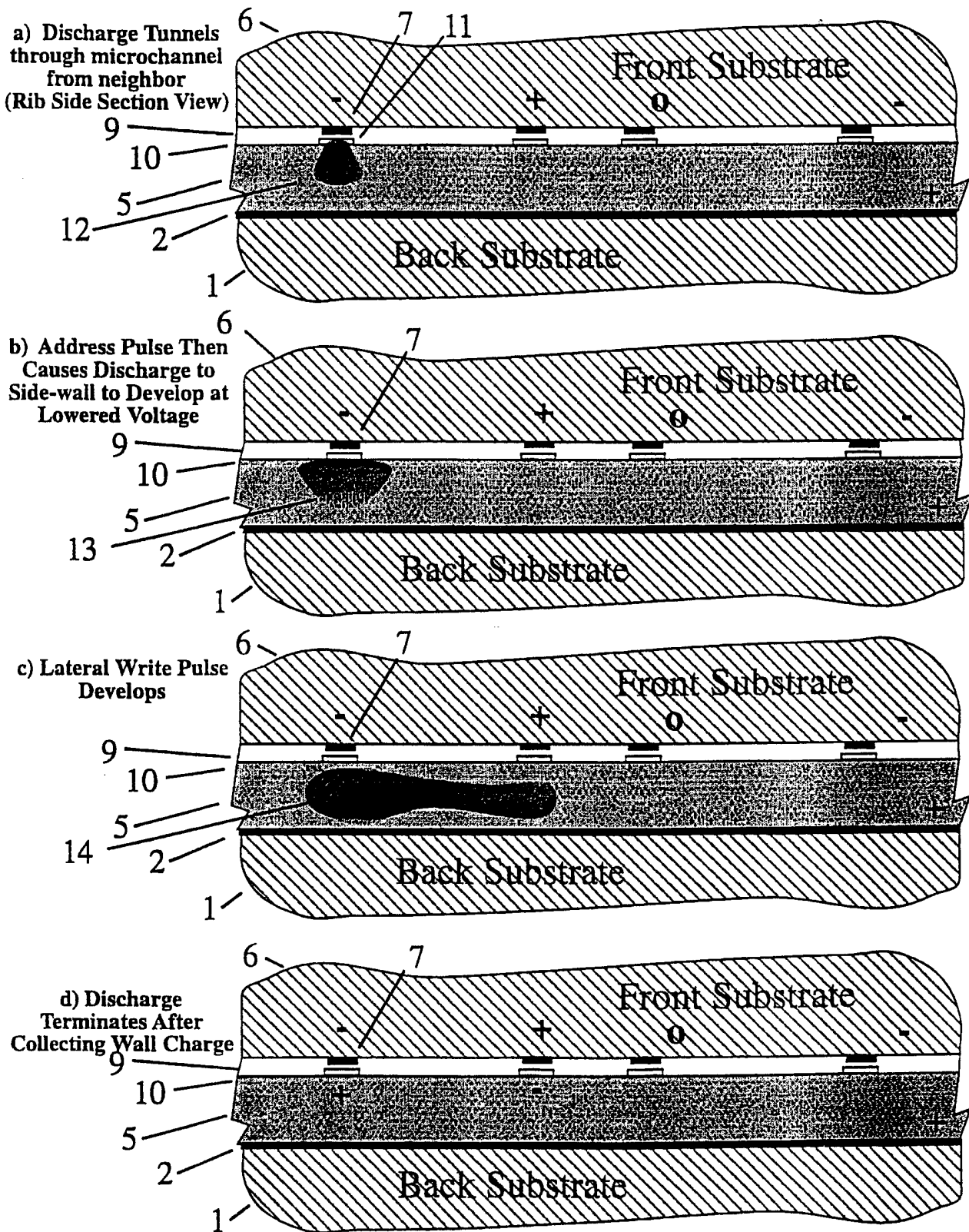

Fig. 5 Tunnel Addressing Sequence

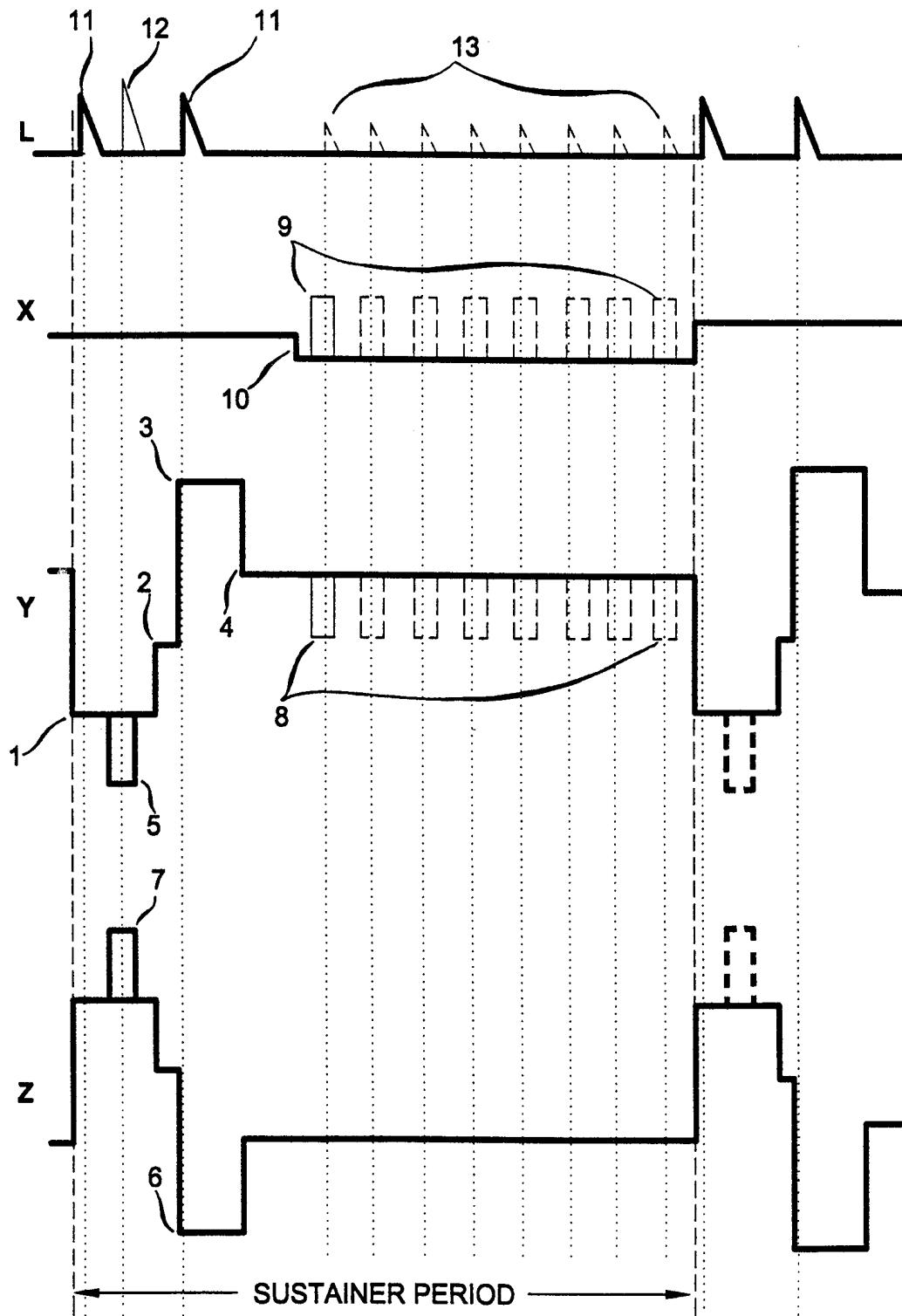

FIG. 6

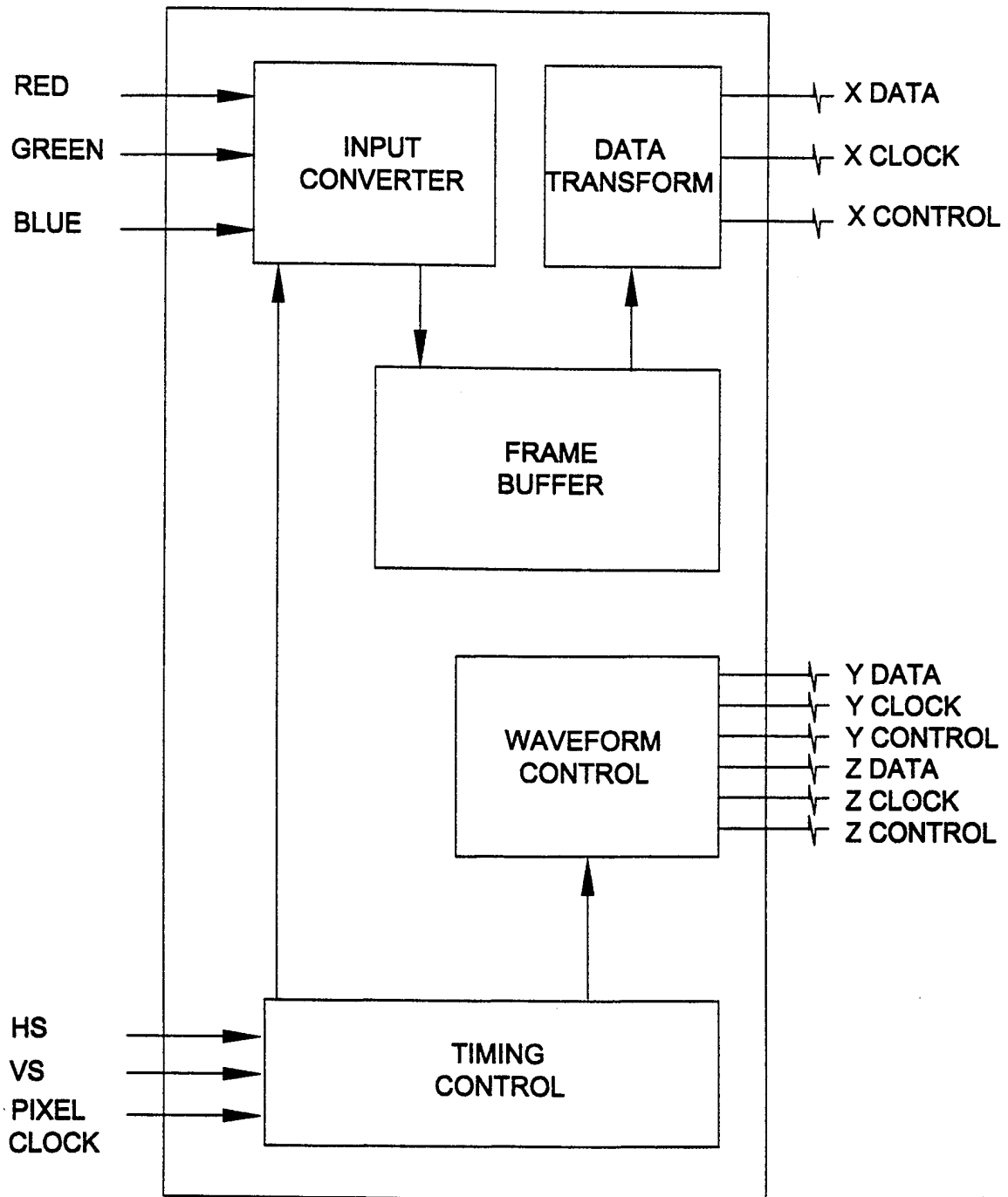

FIG.7a

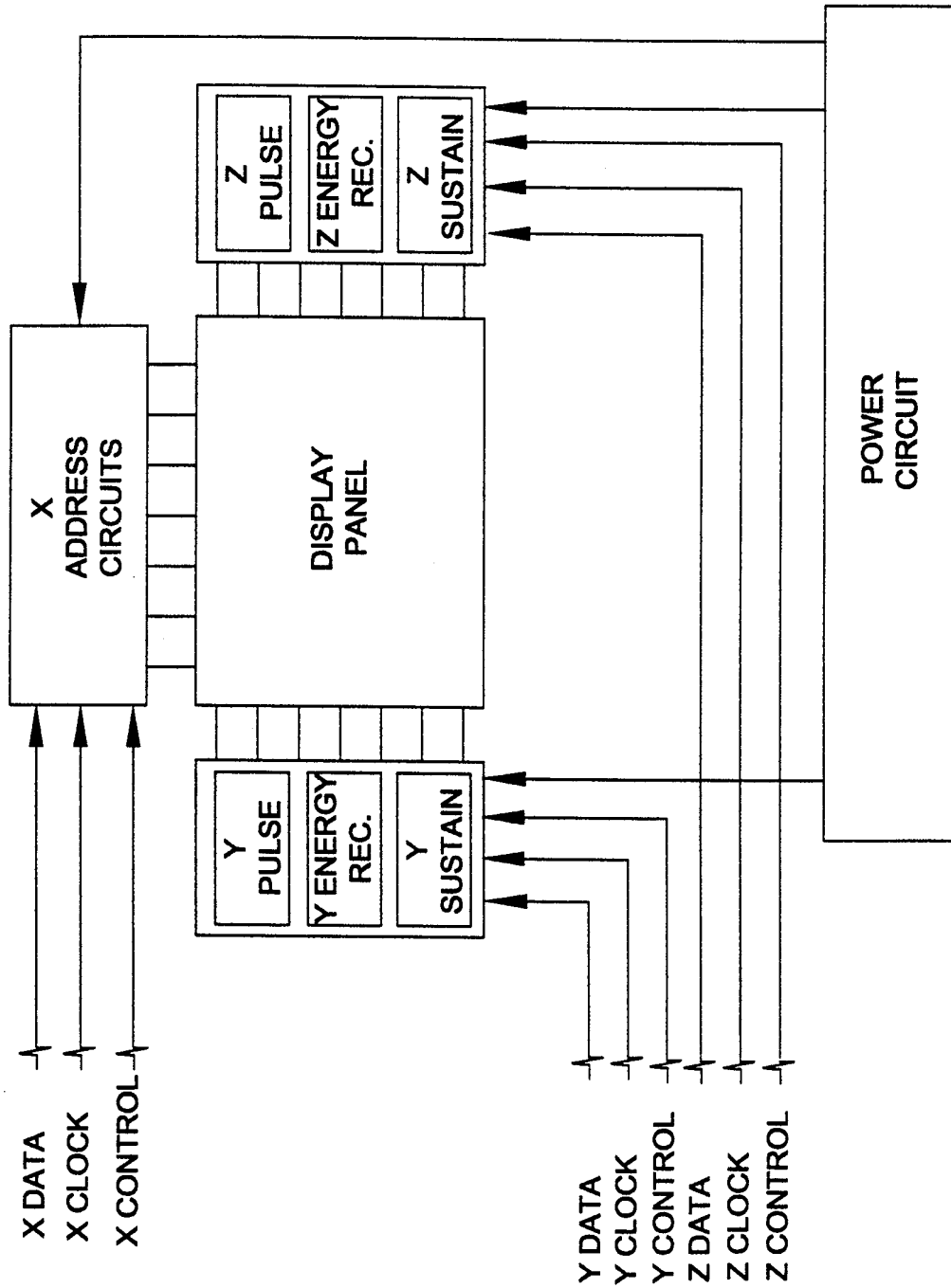

FIG.7b

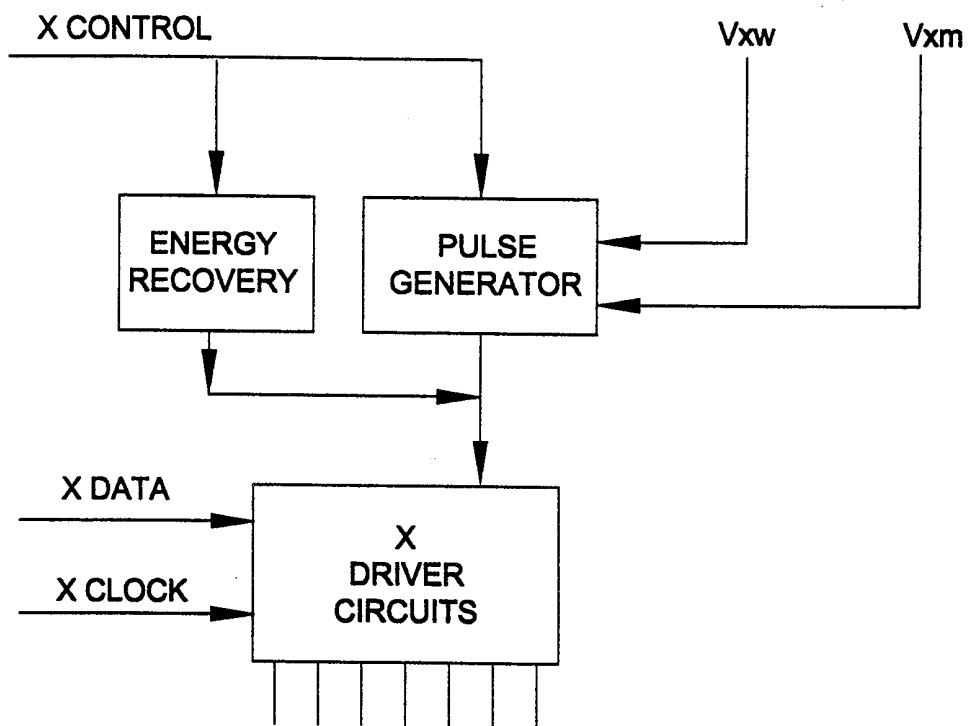

FIG.8

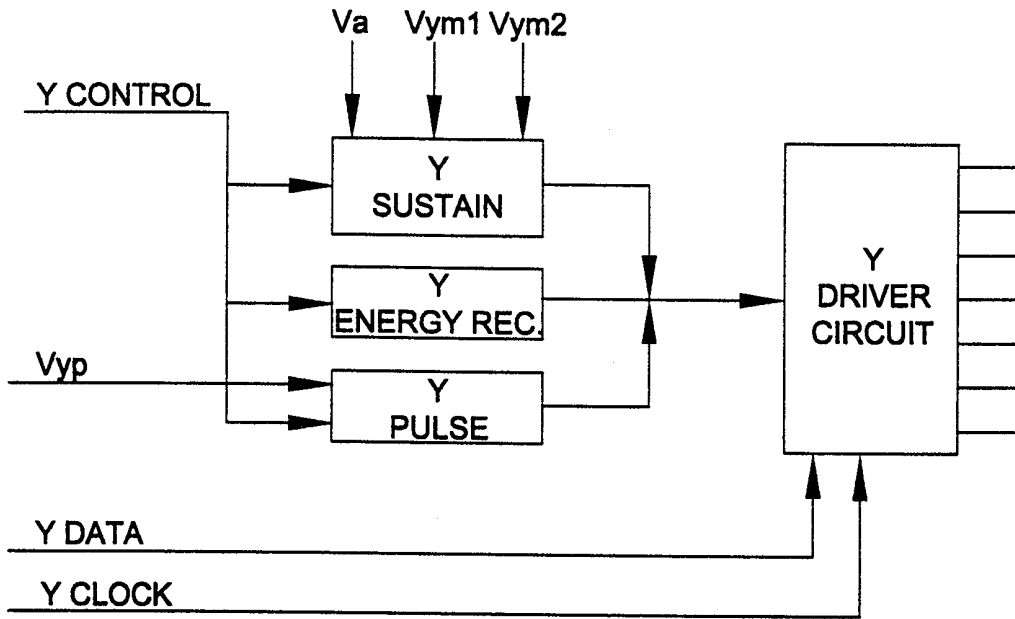

FIG.9

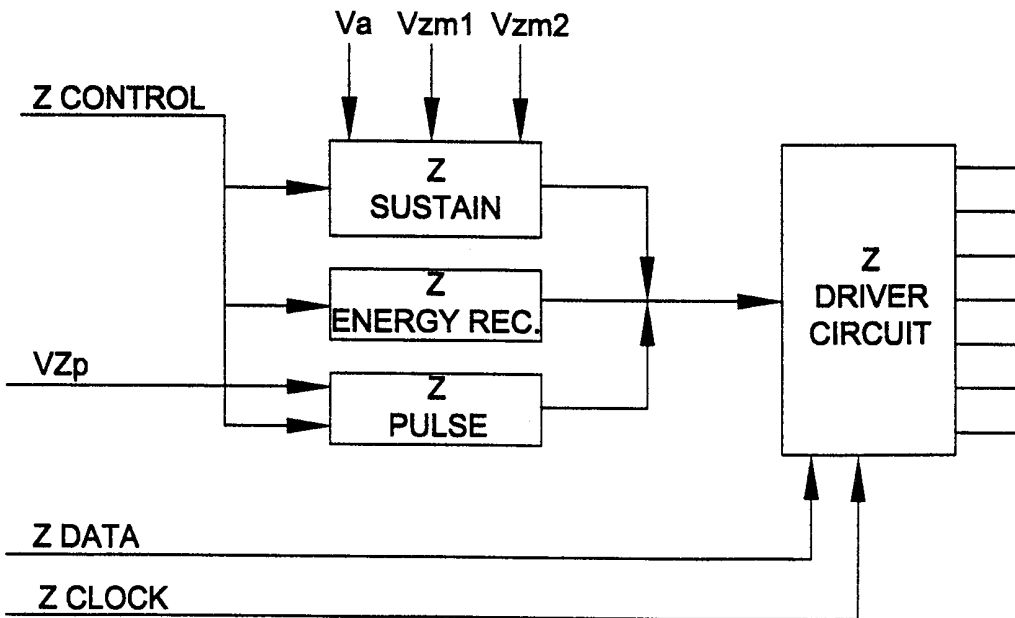

FIG.10

FIG.11

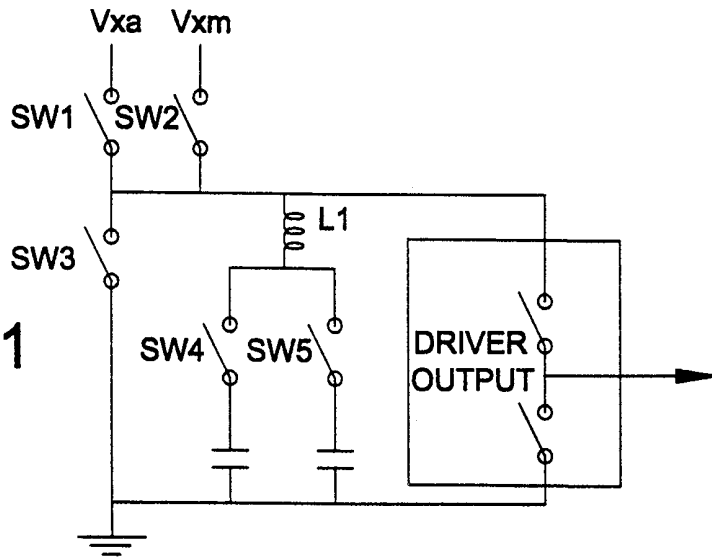

FIG.12

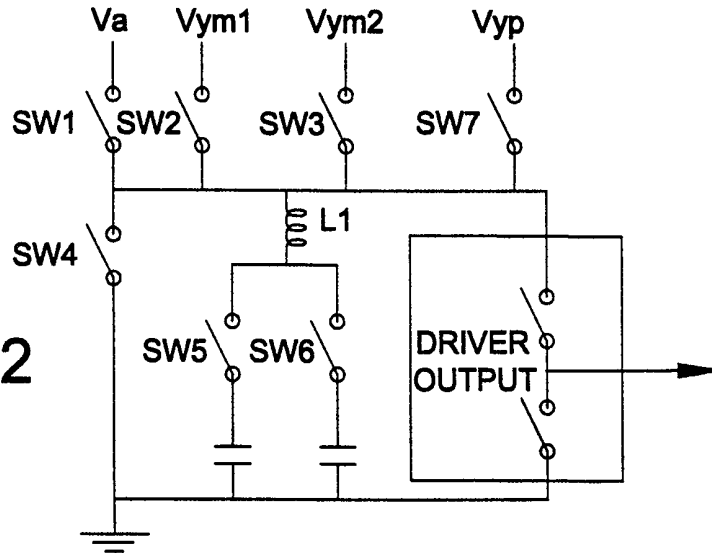
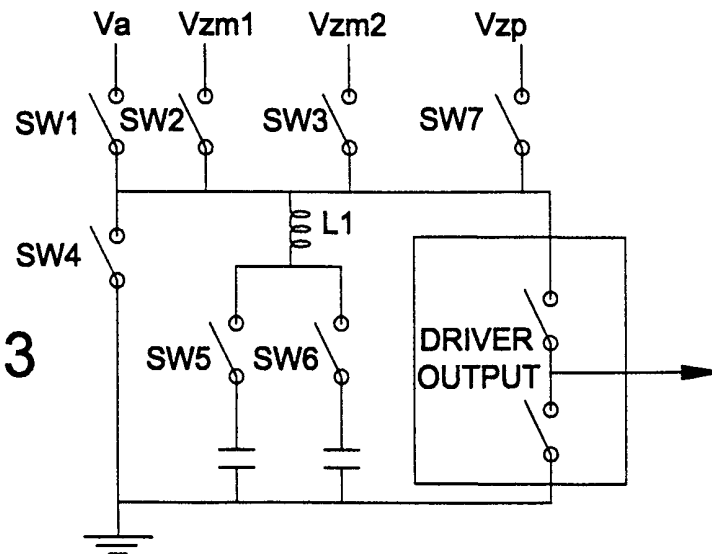

FIG.13



11/12

FIRING VOLTAGE PLOTS
(GEOMETRY TYPE 1 d=100 μ m)

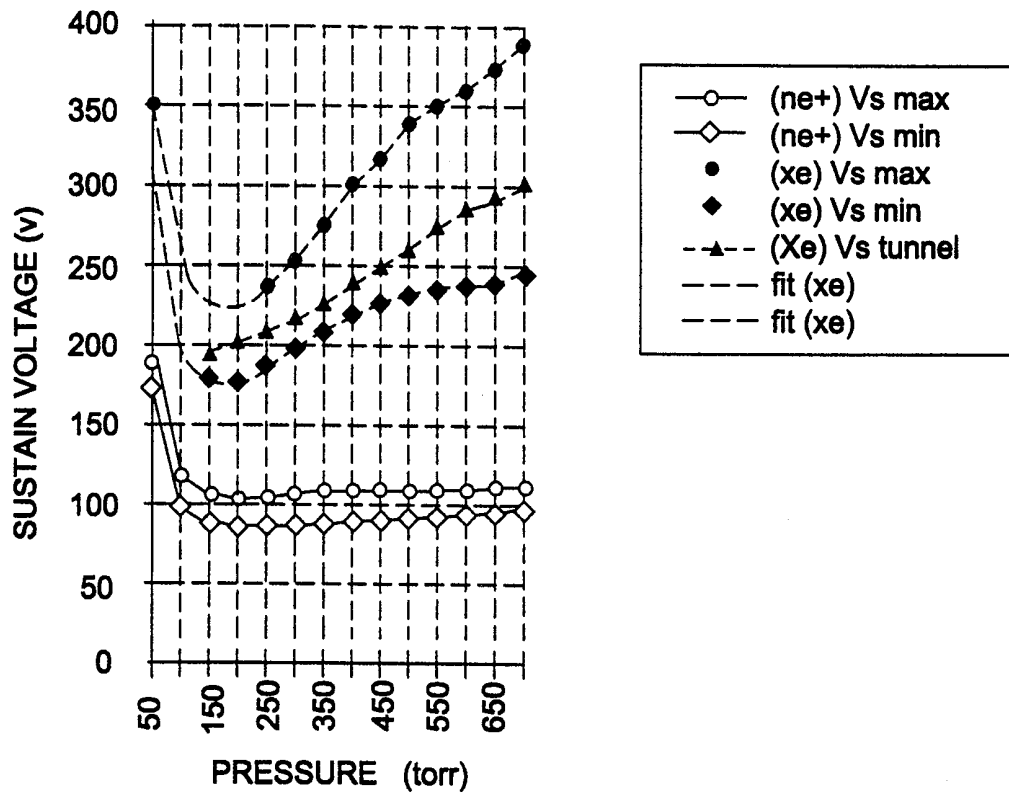

FIG. 14

SUSTAIN RANGE AND EFFICIENCY
(GEOMETRY TYPE 1) AT 500 TORR

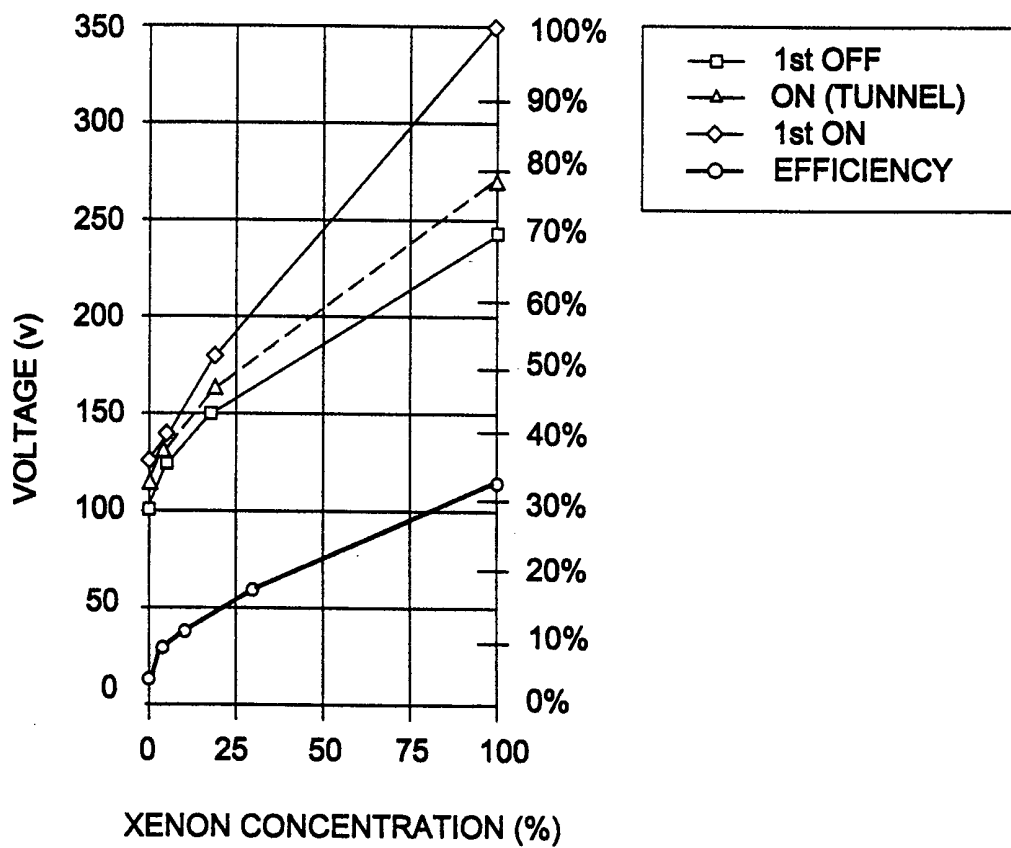

FIG. 15