

May 9, 1933.

H. E. ALLEN

1,908,213

CONTROL DEVICE

Filed Oct. 12, 1928

Fig. 1.

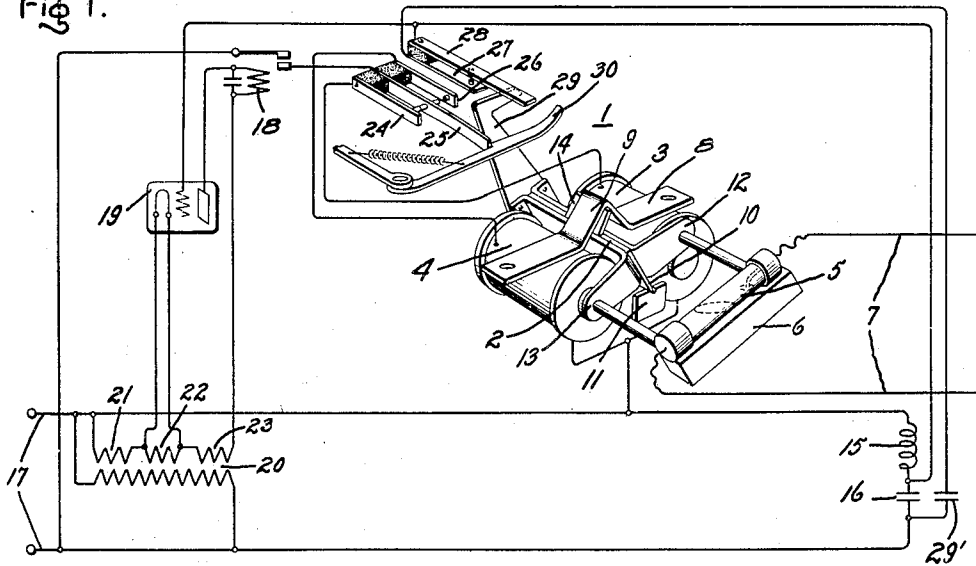
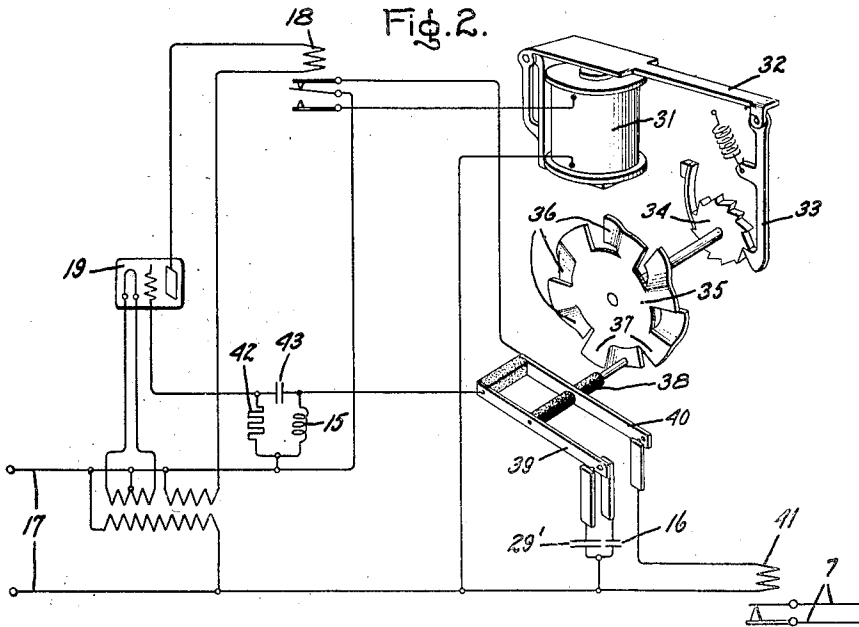

Fig. 2.



Inventor:
Hugh E. Allen,
by *Charles E. Tulla*
His Attorney.

UNITED STATES PATENT OFFICE

HUGH E. ALLEN, OF SCHENECTADY, NEW YORK, ASSIGNOR TO GENERAL ELECTRIC COMPANY, A CORPORATION OF NEW YORK

CONTROL DEVICE

Application filed October 12, 1928. Serial No. 312,191.

My invention relates to means for controlling remote devices such as street lamps and the like in response to current of different frequencies and it has for its purpose to provide means of construction such that it may be practically located near, as in the base of, the individual lamp which it controls and which may be operated in response to carrier current transmitted over the energizing circuit of the lamp.

In carrying my invention into effect a tuned circuit is provided which is connected in shunt with the power conductors over which carrier control currents are transmitted, together with a position relay which is arranged to be operated from one position to the other in response to carrier voltage upon the tuned circuit. The position relay is arranged to control the lamp circuit and is provided with additional contacts for controlling the adjustment of the tuned circuit. That is, when the relay is in one position these contacts are closed and the tuned circuit is resonant at a certain frequency. In response to receipt of current of this certain frequency the relay is operated to the other position, the contacts separate and the tuned circuit is thereby rendered resonant at a different frequency. When current of this different frequency is received the relay is returned to its original position.

The novel features which I believe to be characteristic of my invention are set forth with particularity in the appended claims. My invention itself, however, both as to its organization and method of operation, together with further objects and advantages thereof, may best be understood by reference to the following description taken in connection with the accompanying drawing in which Fig. 1 represents an embodiment of my invention and Fig. 2 represents a modification thereof.

Referring to Fig. 1 of the drawing I have shown at 1 a position relay having an armature 2 which is actuated by a pair of windings 3 and 4. This armature has mounted thereon a circuit making and breaking device comprising a non-conducting tube 5 which is partially filled with mercury and having

sealed-in contact members at the end thereof. This tube is suitably mounted upon a base or supporting member 6 which is suitably attached to the armature 2. The arrangement is such that when the coil 4 has been energized and the armature has been actuated to the position shown in the drawing, the mercury in the tube 5 will flow down to one end thereof as shown and thereby interrupt the circuit between the contact members, and hence between the circuit conductors 7 which are connected thereto. When the coil 3 has been energized, and the armature has been actuated to its opposite position, the tube 5 will be so positioned that both of the electrodes in the opposite ends thereof will be in engagement with the mercury in the tube, and the mercury will comprise a conducting path between the electrodes, and hence between circuit conductors 7. The circuit comprising conductors 7 may be utilized for any suitable remote control purpose, such as controlling a street lamp or the like.

Armature 2 is provided with a holding device which comprises a spring member 8 having its ends securely attached to the frame of the relay, not shown. This spring member, as shown, extends across the relay above the coils 3 and 4, and at a point intermediate the two coils has a V-shaped notch 9 pressed upward therein. The armature 12 is supported from its lower side by means of a knife-edge member 10 which engages a supporting member, or fulcrum 11. This knife-edge member extends between the coils 3 and 4 and longitudinally thereof, and is suitably riveted or welded between two pressed sheet metal members 12 and 13 which comprise the armature and which constitute the flux carrying paths of the coils 3 and 4. At the upper side of the armature and extending edgewise between the spring 8 and the armature is a flat plate-like member 14. When the armature is in either of its two positions, the upper edge of the plate-like member 14 rests in the vertex of the V-shaped notch 9, and its lower edge rests loosely in the upper edge of the armature between the two sheet metal members 12 and 13, the plane of the member 14 extending at a slight angle with

respect to the armature at the point where the two members engage. The downward pressure of the spring member 8 upon the member 14 serves to retain the armature in either of its two positions. When the armature is moved from one position to the other, the member 14 presses upward on the spring member 8 until the armature is about midway between its two positions. When the armature has slightly passed the center position the pressure of the spring downward upon the member 14, together with the attraction of the energized coil, force the armature into its new position with a snap action. Thus, the spring 8 and plate member 14 constitute a toggle, or overcenter, mechanism whereby when the relay is operated from one position to the other it is retained in the actuated position.

The armature 2 has rigidly secured thereto an upward projecting member 29. This member is utilized to operate an additional pair of contacts 27 and 28 and to operate a double throw switch 24, 25, 26 when it is approximately in its center position for purposes later to be set forth. When the relay is in the position shown in the drawing the contact member 28 engages the end thereof and is held out of engagement with contact 27. The upper end of member 29 is of a width such that its engagement with member 28 continues until the armature is about at its center position at which time the contact members 27 and 28 are permitted to engage each other. Slightly thereafter the member 29 engages a locking member 30 which, in the position shown, holds contacts 25 in engagement with contact 24 against its normal spring bias. Member 29 presses and retains the member 30 out from engagement with contact member 25 and permits that member to engage contact 26. When member 29 is actuated back to the position shown it first releases the locking member 30, it then presses contact 28 out from engagement with contact 27 and then presses contact 25 into engagement with contact 24 where it is locked by member 30. It will be seen that upon actuation of the armature in either direction the contacts 27, 28 are operated slightly before the double-throw switch 24, 25, 26 is operated.

For the purpose of providing a frequency responsive device for operating the position relay a tuned circuit comprising inductance 15 and condenser 16 is employed. This tuned circuit has constants such that, together with the line constants, resonance at the carrier frequency is produced. This tuned circuit is connected between conductors 17 which may be supplied with energy from the circuit which energizes the lamp, or other device to be controlled, and which extends to the control, or despatcher's station through the usual distribution transformers. The po-

tential upon the tuned circuit 15, 16 is utilized to control a relay 18 by means of a suitable three-element electron discharge device 19. This electron discharge device is arranged to be energized by means of alternating current of power frequency which is received from the line 17 through transformer 20. The transformer 20 has a plurality of secondary windings 21, 22 and 23. The winding 21 supplies biasing potential to the grid of device 19 through a circuit which extends from the cathode through the winding 21, inductance 15, and a conductor to the grid of device 19. The winding 23 supplies potential to the anode of the discharge device through the relay 18, and the winding 22 supplies heating current to the cathode. The windings 21 and 23 are so connected that the grid is at negative potential of a desired value when the plate is at positive potential.

As thus arranged it will be seen that the discharge device 19 operates as a biased detector of currents having the carrier frequency, which are received from the conductors 17.

The relay 18 has a pair of contacts which, with the relay 1 in the position shown in the drawing, are arranged to connect the relay coil 3 in circuit with the conductors 17. This circuit extends from one side of the circuit 17 through the coil 3, contact members 24 and 25 of the double throw switch, contacts of the relay 18 to the other side of the circuit 17. When the relay is actuated to its opposite position, this circuit is broken at contact 24 and is completed through contacts 25 and 26 and the coil 4. When the armature is about at its center position the member 29 moves out from under member 28, thereby permitting that member to engage contact 27 and connect a condenser 29' in shunt with condenser 16 of the tuned circuit. The winding 4 is now connected in circuit with the contacts of relay 18 and the tuned circuit is resonant at a different frequency. When current of the different frequency is received the relay is operated back to the position shown in the drawing.

As thus arranged the operation of my device is as follows: When current is received from the conductors 17 having the frequency to which the inductance and condenser 16 are tuned, a carrier frequency potential is impressed upon the grid of the discharge device which is of sufficient magnitude to cause energization of the relay 18 and operation of its contacts. The closing of the contacts of relay 18 energizes the winding 3 of relay 1. The winding 3 attracts armature 2 operating it to the position opposite to that shown in the drawing. When the armature of the relay has passed its center position the member 29 moves out from underneath the contact member 28, thereby permitting that member to engage contact 27 to connect condenser 29' in

shunt with condenser 16. When this occurs the tuned circuit is resonant at a different frequency from that which caused the operation of the relay 1. Also, when the armature has passed its center position the member 29 engages the locking member 30 pressing that member against its spring bias and releasing the contact member 25. Contact member 25 then springs into engagement with contact member 26, thereby connecting the winding 4 in circuit with the conductor 17 and the contacts of the relay 18. At this time, however, the tuned circuit is no longer resonant at the received frequency and the current in the anode circuit of device 19 is reduced. Due to the effect of the inductance of the winding of coil 18 and the condenser which is connected in shunt therewith a slight delay will occur before this relay opens its contact. However, the circuit of winding 4 is interrupted at the contacts 24, 25 slightly after the engagement of contacts 27 and 28, thereby preventing energization of the relay coil 4 and the return of the armature 2 to the initial position.

When current having the frequency to which the inductance 15 and the combined capacitance of condensers 16 and 29' are resonant is received the contacts of relay 18 are again closed, thereby energizing the winding 4. When the member 29 is about at its center position it releases the locking member 30, presses and retains contact member 28 upward out of engagement with contact member 27 and presses contact member 25 into engagement with contact 24 where it is retained by locking member 30, all as shown in the drawing.

While, as shown, the device 19 comprises a grid-bias detector, it will of course be understood that this detector may likewise be of the grid-leak type the only difference being that the relay 18 would be normally energized, its contacts closing when the winding becomes deenergized.

In the form of the invention shown in Fig. 2, an electron discharge detector of the grid-leak type and a position relay of different construction are employed. This relay comprises a single coil 31 having armature 32 arranged to actuate a pawl 33 which in turn engages a ratchet wheel 34. Mounted upon the shaft of the ratchet member 34 is a suitable sheet metal disk 35 having about its circumference a plurality of punched-out portions 36 which alternate about the circumference with portions 37 which are in the plane of the disk. A member 38 is biased into engagement with the disk 35 at a position such that as the disk revolves it is adapted for reciprocal operation as it engages the alternate portions 36 and 37. This member 38 carries a pair of contact members 39 and 40, the former of which controls the tuning of the tuned circuit, and the latter of which

serves to operate a relay 40 for controlling the circuit 7.

Biasing potential in this case is produced upon the grid of the electron discharge device 19 by means of a suitable grid leak and condenser combination 42, 43 connected in the usual manner. This potential is normally of a small or zero value such that the relay 18 which is connected in the anode circuit of the discharge device is normally energized, and its armature is in engagement with its upper contact. When carrier current is received over conductors 17 having the frequency to which the inductance 15 and condenser 16 are adapted to resonate, the negative bias upon the grid of device 19 increases and the relay 18 is deenergized. The armature of the relay 18 then engages its lower contact, thereby completing an obvious circuit through the winding 31 of the position relay. This winding then attracts its armature downward operating the pawl 33 against its bias. Nothing further occurs until the supply of carrier current having the frequency mentioned is interrupted. The relay 18 then becomes energized and attracts its armature to the position shown in the drawing, thereby deenergizing the coil 31. The armature 32 and pawl 33 are then actuated upward, the pawl engaging a notch of the ratchet device 34 causing it to move one step in its rotation. Upon rotation of the disk 35 the member 38 slides from engagement with the punched-out portion 36 on to the successive portion 37, and thereby operates its contacts 39 and 40 to the left.

The contact member 39 connects the condenser 29' in circuit with the inductance 15 and disconnects the condenser 16. The contact 40 completes a circuit which extends from one side of the circuit 17 through the armature and upper contact of the relay 18, armature 40, its stationary contact, and relay 41 to the other side of the circuit 17. The relay 41 is then energized to close its contacts. When current of a different frequency, viz. that to which the inductance 15 and condenser 29' are adapted to resonate is received, a similar operation will occur although, in this case, as the disk 35 is revolved the member 38 will slide from engagement with the projecting portion 37 into engagement with the next successive punched-out portion 36, thereby operating contact members 39 and 40 to the right. When this occurs the relay 41 will be deenergized and the condenser 16 will be reconnected in circuit with the inductance 15.

While I have shown and described the particular embodiments of my invention, it will of course be understood that I do not wish to be limited thereto since many modifications, both in the circuit arrangement and in the instrumentalities employed, may

be made without departing from the spirit and scope of my invention, as set forth in the appended claims.

What I claim as new and desire to secure by Letters Patent of the United States, is:

1. The combination, in a receiving circuit, of a circuit tuned to a certain frequency, a relay operable to either of two positions, means controlled by potential variations on said circuit for operating said relay from either position to the other position, and means for tuning said circuit to a frequency different from that of the potential which produced the operation, and means operative when said relay is beyond a point in its travel intermediate the two positions and prior to a point such that said relay is completely operated to either position for actuating said last means.

2. The combination, in a receiving circuit, of a tuned circuit, a relay connected to respond to potential on said tuned circuit, a position relay having a pair of windings, connections whereby when said position relay is in either position, one of said windings is energized in response to operation of said first mentioned relay to operate said position relay to the other position, means controlled by the position relay and operable when said relay is intermediate its two positions to connect said tuned circuit to respond to a different frequency and thereafter to disconnect said one winding and to substitute the other winding in said connections, whereby said relay is responsive to potential on said tuned circuit having a different frequency to operate from said other position to the initial position.

3. The combination, in a receiving circuit, of a three-element electron discharge device having a cathode, a grid and an anode, a tuned circuit connected between the grid and cathode and a relay connected between the anode and cathode whereby said relay responds to variations in potential on said circuit, a device adapted for reciprocal operation between two positions, means for reciprocally operating said device in response to alternate operations of said relay and means responsive to each operation of said reciprocally operating device for adjusting said tuned circuit to respond to current of a different frequency from that which produced the operation.

4. The combination in a receiving circuit of a tuned circuit, a relay having an armature arranged for reciprocal operation between two positions, a pair of windings, said windings being arranged to actuate said armature in opposite directions, means responsive to voltage on said tuned circuit to operate said relay, a double throw switch operated by said armature and arranged when operated to connect the alternate winding of said relay in circuit with said means, means

to prevent actuation of said double throw switch until said armature has been actuated past a position intermediate said two positions and means to change the tuning of said tuned circuit upon each actuation of said armature to a new position and at an instant prior to actuation of said double throw switch.

5. The combination, in a receiving circuit, of a circuit tuned to a certain frequency, a relay having an armature adapted for reciprocal operation, a pair of windings and an energizing circuit, means including a double throw switch for alternately connecting said windings in said energizing circuit in accordance with the position of said relay, means in said energizing circuit to energize the winding connected therein in response to potential on said tuned circuit, a switch controlled by said relay and arranged to change the tuning of said tuned circuit in accordance with the position of the relay, and means to delay operation of said switch until the winding causing operation thereof has been energized for a time sufficient to operate said relay past its center position.

In witness whereof, I have hereunto set my hand this 11th day of October, 1928.

HUGH E. ALLEN.