

(19) World Intellectual Property Organization
International Bureau



(43) International Publication Date
12 September 2008 (12.09.2008)

PCT

(10) International Publication Number
WO 2008/107657 A1

(51) International Patent Classification:

A47G 19/12 (2006.01) C09K 5/06 (2006.01)
A47G 19/22 (2006.01) B65D 1/26 (2006.01)
A47J 41/00 (2006.01) B65D 25/04 (2006.01)
B65D 81/38 (2006.01)

(21) International Application Number:

PCT/GB2008/000715

(22) International Filing Date: 3 March 2008 (03.03.2008)

(25) Filing Language: English

(26) Publication Language: English

(30) Priority Data:

0704271.6 6 March 2007 (06.03.2007) GB
0723652.4 4 December 2007 (04.12.2007) GB

(71) Applicants and

(72) Inventors: **BIRKETT, Richard, John** [GB/GB]; 2 Alexandra Drive, Newport Pagnell, Buckinghamshire MK16 0JD (GB). **HALE, Michael, John** [GB/GB]; 90 High Street, Sharnbrook, Bedfordshire MK44 1PE (GB).

(74) Common Representative: **BIRKETT, Richard, John**; 2 Alexandra Drive, Newport Pagnell, Buckinghamshire MK16 0JD (GB).

(81) Designated States (unless otherwise indicated, for every kind of national protection available): AE, AG, AL, AM, AO, AT, AU, AZ, BA, BB, BG, BH, BR, BW, BY, BZ, CA, CH, CN, CO, CR, CU, CZ, DE, DK, DM, DO, DZ, EC, EE, EG, ES, FI, GB, GD, GE, GH, GM, GT, HN, HR, HU, ID, IL, IN, IS, JP, KE, KG, KM, KN, KP, KR, KZ, LA, LC, LK, LR, LS, LT, LU, LY, MA, MD, ME, MG, MK, MN, MW, MX, MY, MZ, NA, NG, NI, NO, NZ, OM, PG, PH, PL, PT, RO, RS, RU, SC, SD, SE, SG, SK, SL, SM, SV, SY, TJ, TM, TN, TR, TT, TZ, UA, UG, US, UZ, VC, VN, ZA, ZM, ZW.

(84) Designated States (unless otherwise indicated, for every kind of regional protection available): ARIPO (BW, GH, GM, KE, LS, MW, MZ, NA, SD, SL, SZ, TZ, UG, ZM, ZW), Eurasian (AM, AZ, BY, KG, KZ, MD, RU, TJ, TM), European (AT, BE, BG, CH, CY, CZ, DE, DK, EE, ES, FI, FR, GB, GR, HR, HU, IE, IS, IT, LT, LU, LV, MC, MT, NL, NO, PL, PT, RO, SE, SI, SK, TR), OAPI (BF, BJ, CF, CG, CI, CM, GA, GN, GQ, GW, ML, MR, NE, SN, TD, TG).

Declaration under Rule 4.17:

— as to applicant's entitlement to apply for and be granted a patent (Rule 4.17(ii))

Published:

— with international search report

(54) Title: HOT BEVERAGE RECEPTACLE

SECTION THROUGH RECEPTACLE

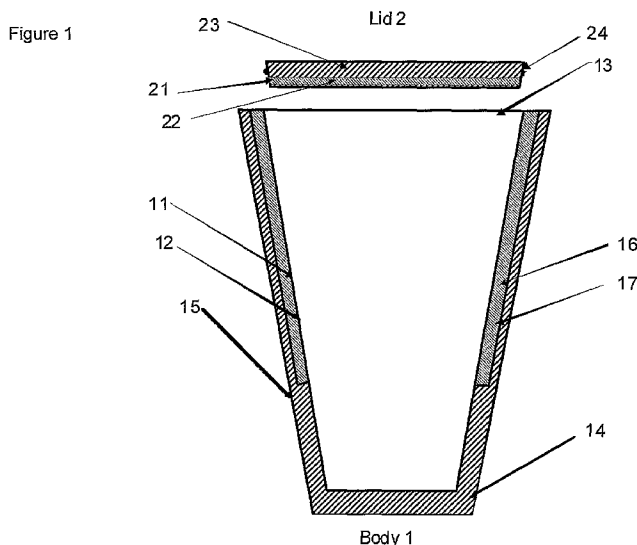

(57) Abstract: A receptacle is provided for hot beverages comprising (i) an inner vessel with an upper open end, a closed lower end and a wall connecting the upper and lower end; (ii) an insulated outer shell; (iii) a compartment disposed between the inner vessel and the outer shell comprising a phase change material for absorbing thermal energy from a hot beverage in the inner vessel to cool the hot beverage and then releasing the thermal energy to the beverage to maintain the temperature of the cooled beverage; and (iv) a lid for the open end of the vessel, which lid comprises a compartment comprising a phase change material in the base of the lid, and an insulating layer.

WO 2008/107657 A1

HOT BEVERAGE RECEPTACLE

Field and Background to the Invention

This invention relates to receptacles/containers particularly adapted for controlling the temperature of food or beverages therein, such as coffee, tea, soup and the like.

Consumers of hot beverages have increasingly demanded that the beverage should be maintained at a temperature acceptable for drinking for an extended period, for example when commuting, at work, or when working at home. Common single-walled containers, such as mugs or cups made of metal, ceramic, plastic or paper, allow the hot beverage to cool too rapidly. One common solution to this problem has been to use double-walled containers with various means of insulation between the inner and outer wall. These containers are widely available commercially. The insulation reduces heat loss, and so retards the cooling rate of the beverage within the container.

However, this solution exacerbates a second known problem with hot beverage consumption. Typically, a hot beverage may be made directly in a cup or mug, by the addition of very hot water at temperatures of 80 to 100°C, or it may be dispensed or poured from a brewing device where the beverage has been maintained at a temperature of 80°C or more. These temperatures are typically too hot for safe or comfortable consumption, and may even present a burn or scald hazard if consumed injudiciously, or spilled accidentally. In a conventional non-insulated container the beverage will cool within a few minutes to a temperature safe and comfortable for consumption. However, in the case of an insulated container, cooling is very much slower, as described above, and the hot beverage may maintain a temperature above the threshold for comfortable or safe drinking for a considerable time. The problem is therefore both (i) how to reduce the temperature of a freshly made or dispensed hot beverage to a safe and comfortable temperature for consumption, and (ii) how to maintain the temperature in the normal drinking range of consumers for an extended period.

The prior art (e.g. US Patent No. 2,876,624, US Patent No. 6,968,888 and WO98/45208) has taught that one solution for rapidly lowering the temperature of a hot liquid to an acceptable temperature for consumption and then maintaining it within an acceptable range over an extended period of time can be achieved by
5 constructing a double walled container, with an inner vessel having an open upper end and closed lower end, and an insulated outer shell spaced from the inner vessel to provide an interstitial chamber containing a phase change material. This phase change material regeneratively absorbs thermal energy from the liquid to cool the liquid and then releases the thermal energy back to the liquid
10 to maintain the temperature of the liquid.

Whilst investigating the performance of hot beverage receptacles, such as mugs, based on this principle, we have surprisingly found that in use the receptacles do not perform as well as might be expected. Specifically, the rate of temperature
15 decrease at the top of the receptacle is much slower than at the bottom. Since the user drinks the liquid from the top of the receptacle this means that the beverage takes much longer to cool to a temperature suitable for drinking than is acceptable to a typical user. Accordingly, there is a need for an improved hot beverage receptacle that overcomes the above problem that we have identified.

20

Summary of the Invention

We have now found that by providing the beverage receptacle, made according to the principle described, with a lid that includes a phase change material, the rate of cooling in the upper region of the liquid to the desired drinking temperature
25 is enhanced. This is achieved without any significant, adverse effect on the time at which the liquid remains at a comfortable drinking temperature.

Accordingly, in a first aspect the present invention provides a hot beverage receptacle, such as a cup or mug, comprising: (i) an inner vessel with an upper
30 open end, a closed lower end and a wall connecting the upper and lower end; (ii) an insulated outer shell; (iii) a compartment disposed between the inner vessel and the outer shell comprising a phase change material for absorbing thermal energy from a hot beverage in the inner vessel to cool the hot beverage and then

releasing the thermal energy to the beverage to maintain the temperature of the cooled beverage; and (iv) a lid for the open end of the vessel, which lid comprises a phase change material in the base of the lid, and an insulating layer.

5 In a related aspect, the present invention provides a hot beverage receptacle, such as a cup or mug, comprising: (i) an inner vessel with an upper open end, a closed lower end and a wall connecting the upper and lower end; (ii) an insulated outer shell; (iii) a compartment disposed between the inner vessel and the outer shell comprising a phase change material for absorbing thermal energy from a
10 hot beverage in the inner vessel to cool the hot beverage and then releasing the thermal energy to the beverage to maintain the temperature of the cooled beverage; and (iv) a lid for the open end of the vessel, which lid comprises a compartment comprising a phase change material for inducing evaporation from the upper surface of the liquid, and an insulating layer.

15

In a second aspect, the present invention also provides a hot beverage receptacle, such as a cup or mug, for rapidly lowering the temperature of a hot beverage contained therein to a temperature suitable for human consumption and maintaining the beverage within a warm temperature range for an extended
20 period of time, the receptacle comprising: (i) an inner vessel with an upper open end, a closed lower end and a wall connecting the upper and lower end; (ii) an insulated outer shell; (iii) a compartment disposed between the inner vessel and the outer shell comprising a phase change material for absorbing thermal energy from a hot beverage in the inner vessel to cool the hot beverage and then
25 releasing the thermal energy to the beverage to maintain the temperature of the cooled beverage; and (iv) a lid for the open end of the vessel, which lid comprises a phase change material in the base of the lid, and an insulating layer.

In a related aspect the present invention provides a hot beverage receptacle,
30 such as a cup or mug, for rapidly lowering the temperature of a hot beverage contained therein to a temperature suitable for human consumption and maintaining the beverage within a warm temperature range for an extended period of time, the receptacle comprising: (i) an inner vessel with an upper open

end, a closed lower end and a wall connecting the upper and lower end; (ii) an insulated outer shell; (iii) a compartment disposed between the inner vessel and the outer shell comprising a phase change material for absorbing thermal energy from a hot beverage in the inner vessel to cool the hot beverage and then releasing the thermal energy to the beverage to maintain the temperature of the cooled beverage; and (iv) a lid for the open end of the vessel, which lid comprises a compartment comprising a phase change material for inducing evaporation from the upper surface of the liquid, and an insulating layer.

The inventors have also found that it is not necessary of the phase change material to be present throughout the walls of the receptacle: it need only be present in the upper portion. Thus, since the phase change material can represent a substantial part of the cost of manufacturing the receptacle, this finding enables significant cost reductions compared with the prior art. This aspect of the invention can be applied to a wide range of receptacles, including those used to serve food. Accordingly in this aspect the receptacle is termed a 'container' to distinguish this aspect from the first aspect.

Thus, in a third aspect the present invention also provides a container for hot food and drinks comprising:

- (i) an inner vessel with an upper open end, a closed lower end and a wall connecting the upper and lower end;
- (ii) an insulated outer shell;
- (iii) a compartment disposed between the inner vessel and the outer shell comprising a phase change material for absorbing thermal energy from a hot foodstuff or drink in the inner vessel to cool the hot foodstuff or drink and then releasing the thermal energy to the foodstuff or drink to maintain the temperature of the cooled foodstuff or drink, wherein the compartment and the phase change material extend around the upper portion of the inner vessel only; and
- (iv) a lid for the open end of the vessel, which lid comprises a compartment comprising a phase change material in the base of the lid, and an insulating layer.

In a preferred embodiment, the phase change material is in thermal contact with at least the upper third of the outer surface of the wall(s) of the inner vessel.

5 Additionally, or alternatively, in one embodiment, the phase change material is in thermal contact with at least 40% of the outer surface of the wall(s) of the inner vessel.

10 In a fourth aspect, the present invention provides a container for rapidly lowering the temperature of a hot foodstuff or drink contained therein to a temperature suitable for human consumption and maintaining the foodstuff or drink within a warm temperature range for an extended period of time, the container comprising:

- (i) an inner vessel with an upper open end, a closed lower end and a wall connecting the upper and lower end;
- 15 (ii) an insulated outer shell;
- (iii) a compartment disposed between the inner vessel and the outer shell comprising a phase change material for absorbing thermal energy from a hot foodstuff or drink in the inner vessel to cool the hot foodstuff or drink and then releasing the thermal energy to the foodstuff or drink to maintain the temperature
- 20 of the cooled foodstuff or drink, wherein the compartment and the phase change material extend around the upper portion of the inner vessel only; and
- (iv) a lid for the open end of the vessel, which lid comprises a phase change material in the base of the lid, and an insulating layer.

25 In a preferred embodiment, the phase change material is in thermal contact with at least the upper third of the outer surface of the wall(s) of the inner vessel.

30 Additionally, or alternatively, in one embodiment, the phase change material is in thermal contact with at least 40% of the outer surface of the wall(s) of the inner vessel.

Description of the Figures

Figure 1 – shows a cross section of a receptacle/container of the invention.

- 5 Figure 2 – shows various views of a particular embodiment of a body of a receptacle/container of the invention.

Figure 3 – shows cooling temperature profiles of several of the receptacles described in the text: 1) a receptacle with insulation only (non PCM), typical of
10 containers available commercially, 2) a receptacle with insulation and PCM, typical of those described in the prior art, showing the differential temperature between upper and lower liquid regions, 3) a receptacle and lid with insulation and PCM, as described in the invention, showing no differential temperature between upper and lower liquid regions.

15

Detailed Description of the Invention

Unless defined otherwise, all technical and scientific terms used herein have the same meaning as commonly understood by one of ordinary skill in the art.

- 20 Throughout this specification, reference to numerical values, unless stated otherwise, is to be taken as meaning “about” that numerical value. The term “about” is used to indicate that a value includes the inherent variation of error for the device and the method being employed to determine the value, or the variation that exists among the study subjects.

25

- The receptacles of the present invention are designed to hold hot beverages. The term “beverage” means liquids and semi-liquids. Foodstuffs such as porridge, casseroles, gravy and pureed baby food are therefore excluded from this definition. Liquids include mulled wine, tea, coffee, hot chocolate, Ovaltine™
30 and the like. Semi-liquids include soup, or instant noodles with sauce, which contain solid components in a liquid, but which can still be drunk. The viscosity of the beverage is typically less than 10,000 cP (10 Pa.s), preferably less than 5,000

or 1,000 cP (5 or 1 Pa.s), such as less than 100 cP (0.1 Pa.s). Viscosity values are measured at 25°C, 1 atm.

It is preferred that the receptacle is used to hold liquids and semi-liquids having a free liquid content of at least 20% w/w, such as at least 30, 40 or 50 % w/w. The term "free liquid" refers to liquid that can be separated from the solid components, i.e. if the contents are poured through a standard domestic sieve with 1 mm aperture, the free liquid would be the liquid passing through the sieve.

In one aspect of the present invention, the receptacles of the present invention are designed to hold beverages for direct consumption from the receptacle by an individual. Such receptacles therefore are generally in the form of a cup or a mug. Flasks and other receptacles which are only designed to hold the beverage, with the beverage being dispensed into another vessel for consumption, are specifically excluded as receptacles of the present invention, but are not excluded from the definition of containers as referred to in other aspects of the invention. In some embodiments, the receptacle is specifically adapted to enable the beverage to be consumed from the receptacle when the lid is on, e.g. the lid contains an opening as described below. Preferably the receptacle has a volume of less than 1 litre, such as from 200 to 750 ml.

In another aspect of the invention, the containers of the present invention, as distinct from the receptacles referred to above, which have the phase change material in an upper portion of the container and not in the lower portion, are designed to hold hot foodstuffs and drinks. The term "foodstuff or drink" includes liquids, such as mulled wine, tea, coffee, hot chocolate, Ovaltine™ and the like; semi-liquids, such as soup, or instant noodles with sauce, which contain solid components in a liquid; as well as foodstuffs of relatively high viscosity, such as porridge, casseroles, gravy and pureed baby food. The viscosity of the foodstuff or drink is typically less than 10,000 cP (10 Pa.s), preferably less than 5,000 or 1,000 cP (5 or 1 Pa.s), such as less than 100 cP (0.1 Pa.s). Viscosity values are measured at 25°C, 1 atm.

It is preferred that the container is used to hold liquids and semi-liquids having a free liquid content of at least 20% w/w, such as at least 30, 40 or 50 % w/w. The term "free liquid" refers to liquid that can be separated from the solid components, i.e. if the contents are poured through a standard domestic sieve with 1 mm aperture, the free liquid would be the liquid passing through the sieve.

In one embodiment, the containers of the present invention are designed to hold hot foodstuffs and drinks for direct consumption from the container by an individual, as described for receptacles above. Such containers therefore are generally in the form of a cup or a mug. Preferably the container has a volume of less than 1 litre, such as from 200 to 750 ml.

In another embodiment, the containers of the present invention are designed to hold larger quantities of hot foodstuffs and drinks for consumption by a number of individuals. The containers may therefore be in the form of gravy/sauce boats, jugs and the like. The volume of such containers is preferably less than 2 litres.

The description below typically refers to receptacles. Unless otherwise stated, features described below are equally applicable to both receptacles and containers.

Referring to figure 1, the receptacle has two main parts: a body (1) that holds the consumable contents, and a lid (2). The body comprises an inner vessel (11), which in use holds the consumable contents. Accordingly, the inner vessel typically has a wall (12) or walls, a top and a bottom, otherwise expressed as an upper end and a closed lower end. The body has an opening (13) through which the beverage can be placed in the vessel, and through which the beverage can be displaced or consumed. Typically the opening is in the upper end but it could also be in an upper portion of the wall. The inner vessel can, for example, be made from plastic, such as high impact polystyrene (HIPS) or metal, such as stainless steel, aluminium, aluminium alloys, copper or copper alloys. It is preferred that the inner vessel is made from a material having a conductivity of greater than 5 or 10 W/mK – stainless steel has a conductivity of 16 W/mK.

The body may comprise one or more handles to enable a user to grip the body. A version suitable for a child may, for example, have two handles.

- 5 The body also includes an insulated outer shell (14). Any suitable insulating material can be used, such as expanded polyurethane, polyethylene or polystyrene. The insulating material may also be a vacuum, or an aerogel. The insulating material can also be a closed-cell foam or an open-cell foam. The layer of insulating material may be of any suitable thickness, such as from 1 to 6 mm,
10 e.g. from 2 to 5 mm.

In one embodiment, the insulating material is resiliently deformable so as to accommodate changes in the volume of the phase change material described below.

- 15 The insulating material may form the outermost layer of the receptacle or it may be disposed between the outermost layer (15) (such as an outermost layer of high impact polystyrene (HIPS) or stainless steel), termed the outer casing, and the inner vessel, as shown in figure 1. The insulating layer preferably surrounds
20 the entire inner vessel.

- The body also includes a compartment (16) disposed between the inner vessel and the outer shell comprising a phase change material (17), such that the phase change material is in thermal contact with the wall of the inner vessel. In use, the
25 phase change material absorbs thermal energy from the hot beverage in the inner vessel to cool the beverage and then releases the thermal energy to the beverage to maintain the temperature of the cooled beverage. The compartment, and therefore the phase change material, may surround substantially the entire inner vessel, i.e. the walls and bottom of the inner vessel. Alternatively, the
30 compartment, and therefore the phase change material, may only partially surround the inner vessel (as shown in figure 1). In particular, the phase change material may only surround the upper portion of the inner vessel, such as only the

upper third of the inner vessel or the uppermost 60, 50, 40 or 30% of the inner vessel.

5 Preferably, the phase change material is in thermal contact with at least 30, 40, 50 or 60% of the outer surface of the wall(s) of the inner vessel. Preferably, the phase change material is in thermal contact with at least the upper third of the wall(s) of the inner vessel, such as the upper two thirds.

10 In the case of the containers of the invention, the phase change material only partially surrounds the inner vessel (as shown in figure 1). Specifically, the phase change material only surrounds the uppermost portion of the inner vessel and not the lower portion. The inventors have found that this enables a reduction in the amount of phase change material required with little to no loss in function. Preferably the phase change material only surrounds the upper third of the inner
15 vessel or the uppermost 60, 50, 40 or 30% of the inner vessel. Preferably, the phase change material is in thermal contact with at least 30, 40, 50 or 60% of the outer surface of the wall(s) of the inner vessel.

20 Examples of phase change materials include waxes (e.g. beeswax, paraffin wax), fatty acids (stearic acid, palmitic acid and myristic acids), fats, heavy alcohols (e.g. cetyl alcohol), crystalline alkyl hydrocarbons and crystalline salts, e.g. crystalline salt hydrates, such as sodium acetate trihydrate. Preferred phase change materials have a phase change temperature of from 45 to 75°C, such as from 50 to 70°C, or 50 to 65°C. Phase change materials are preferably food
25 grade.

Mixtures of phase change materials can also be used. In one embodiment, a mixture is used of one or more crystalline salts, such as sodium acetate trihydrate, and one or more waxes, so that the wax melts preferentially and acts
30 as a thermal transfer medium to the crystalline solid. In this embodiment, the v/v ratio of the salt(s) to the wax(es) is preferably at least 2:1, more preferably at least 4:1. The v/v ratio of the wax(es) to the salt(s) may be less than 1:1, such as less than 1:2.

Where the phase change material includes one or more crystalline salts, it may be desirable to include means to assist with nucleation of the crystalline form to avoid potential supercooling of the molten phase change material as it cools.

5 Suitable methods of doing this can be found in standard texts on nucleation (such as Nucleation, ed. AC Zettlemoyer, Marcel Dekker, New York, 1969) and include using inorganic or organic crystals or other particles, or making at least one of the surfaces of the compartment rough.

10 Further, where the phase change material includes one or more crystalline salts, it may be desirable to include additive thickener materials, such as polyvinyl alcohols, paraffins, and either acetone or formaldehyde (see Wada et al. US 4,561,989) to optimise phase change behaviour and make it more consistent over multiple cycles.

15

In one embodiment, the compartment in which the phase change material is held is a single continuous compartment. In an alternative embodiment, the phase change material is held in a plurality of compartments. This is so that if one compartment ruptures, especially on the side in contact with the inner vessel and
20 therefore the contents of the inner vessel, the amount of phase change material released into the contents of the container is reduced. Compartmentalisation can, for example, be achieved by providing ribs, typically in a substantially horizontal and/or substantially vertical orientation, as shown in figure 2 where vertical ribs (20) are provided. One such way to achieve this where the insulating
25 material is a closed-cell foam is to use this same material to form the compartmentalising ribs.

With reference to figure 1, the receptacle of the present invention also includes a lid (2), which fits the open end of the inner vessel. The lid (2) comprises a phase
30 change material (21) in the base of the lid (22), and an insulating layer (23). The materials used as the phase change material and insulating layer are typically as described above. In use, the insulating layer (22) is uppermost, i.e. is external to the phase change material (21). The phase change material (21) is therefore

nearer to, and in thermal contact with, the inner vessel (11). In this way, heat transferred by evaporation will be transferred to the phase change material via contact with the underside of the lid. The phase change material will typically be held in a compartment in the base of the lid in a similar fashion as is described above in relation to the body.

The lid may include a gasket or seal, such as a rubber ring (24), to provide a tight fit between the lid and the inner vessel.

The lid may include a screw thread which engages with a screw thread of the body of the container.

In one embodiment, the lid includes an opening through which the beverage can be consumed. The opening may, for example, be a shaped spout, optionally fitted with a cover, which may slidingly engage to seal or open the spout.

In another embodiment, the opening may be of suitable dimensions to allow a straw or similar article to be inserted into the opening and thus into the contents of the inner vessel.

In use, the receptacle of the invention is used to rapidly lower the temperature of a hot beverage (or drink or foodstuff as appropriate in the case of a container of the invention) contained therein to a temperature suitable for human consumption and maintain the beverage within a warm temperature range for an extended period of time.

Preferably, the receptacle is capable of lowering the temperature of a hot beverage (or drink or foodstuff as appropriate) from 90°C to 70°C at the top of the beverage in less than 30 minutes, more preferably less than 20 or 15 minutes.

“At the top of the beverage” means in the top 1 cm of the beverage.

A warm temperature range is generally the temperature range at which a hot beverage is considered comfortable to humans to consume. Preferably said

warm temperature range is from about 45°C to about 75°C, such as from about 50°C to about 70°C (see HS Lee and M O'Mahony, J. Food Science, **67(7)**, 2002, 2774-2774 and references therein). In the case of beverages for infants or the elderly, the preferred temperature range may be lower, such as from about 45°C to about 60°C.

Preferably said extended period of time is at least 60 minutes, preferably at least 90, 100, 110 or 120 minutes.

10 The present invention will now be described further with reference to the following examples, which are illustrative only and not limiting.

Examples

15 The first prototypes were constructed from inner and outer, high impact polystyrene (HIPS) mouldings, enclosing a 4mm thick expanded polystyrene insulation layer with 2mm clearance between the insulation and inner casing. For the control this was simply left as an air filled gap, whereas, for the experimental samples, it contained the phase change material (PCM), sodium acetate.

20 The inner vessel of the prototypes was filled with a liquid at a temperature of 90°C. Spot temperature measurements were then taken, with a single probe thermometer, every minute after stirring the contents, yielding a bulk representative value with no spatial variation. Two arbitrary parameters were specified to quantify performance. Pull-down rate was defined as the time taken
25 for the hot liquid to reach a drinkable temperature, defined as 70°C. Consumption time was the duration that the liquid remains in the acceptable, warm, temperature range, with the lower threshold defined as 50°C

30 From the initial trials (**Key Stage 1**) it was clear that heat losses through the exposed top surface dominated the cooling process and, although there were differences in the performance between prototypes with and without PCM, these were not as pronounced as anticipated (see results table 1, below). The first refinement, therefore, was to add a cover (**Key Stage 2**). There was a marked

improvement in performance with a pull-down rate of 8 minutes compared with 22, and a consumption time of 72 minutes compared with 50 using sodium acetate as the PCM (see results table 1, below).

5 The simple cover was then replaced with an insulated lid in order to minimise the heat loss by this route, which again substantially improved performance (**Key Stage 3**). At this point the temperature distribution in an undisturbed system was monitored using a multi-channel data logger, rather than periodic, representative
10 measurements of the stirred bulk. Three sensors were mounted vertically through the height of the liquid along the axis of the cup, recording temperatures at the top, middle and bottom of the receptacle. This revealed that there was large disparity between the temperature histories in the different locations within the experimental prototypes. Liquid at the top of the receptacle cooled far more slowly than liquid at the base, the difference amounting to typically 13 minutes to
15 reach the threshold of 70°C (see results table 1, below). Since liquid is drunk from the top of a receptacle where the cooling effect of the PCM is far less apparent, this reduces significantly the utility of the receptacle.

It was perceived that the reason for this was the preferential cooling of the hot
20 liquid in the vicinity of the inner casing contact surface. Cooler liquid, being denser than that at higher temperature, will fall under gravity to the bottom of the receptacle, displacing hotter fluid which is forced upwards. Because the heat from the top surface is effectively trapped by the lid insulation above it, the headspace and bottom surface of the lid is at virtually the same temperature as the top
25 surface of the contents. Therefore there is practically no temperature gradient to induce evaporative cooling, and heat losses are largely conduction limited.

The proposed solution to this problem was to provide PCM material in the base of the lid, anticipating that vapour evaporated from the top surface of the fluid would
30 condense on the bottom surface of the lid, and the latent heat of vaporisation released would be absorbed by the latent heat of fusion as the PCM melted without an increase in temperature. Thus the under surface of the lid would be held at a substantially lower temperature than the fluid surface, establishing a

temperature gradient across the headspace that would maintain evaporative cooling over a prolonged period.

5 Prototype lids were constructed with a metal cup forming the base, and filled with 15ml of PCM with 5mm of polyurethane insulation above it. Repeat cooling trials were carried out and the pull-down times for the top surface of the liquid were reduced from, typically, 21 minutes to 10 (**Key Stage 4**) (see results table 1, below). Consumption times were also reduced from around 2 hours 15 minutes to about 1hour 50 minutes, but this was not considered to be a major impairment
10 of the overall performance.

The mechanism of cooling identified and described above suggested further modifications to the design. As the cooled liquid around the periphery accumulates at the base of the receptacle under natural convection, there is less
15 need for PCM in this region, and insulation alone should suffice to keep the contents at acceptable temperatures. As the PCM will be an expensive component in the final product assembly, any means of reducing the quantity required without impairing performance would be valuable. Subsequent prototypes were produced in which the PCM was largely located as a coating
20 around the upper two thirds of the inner casing. In essence there was no detrimental affect on the performance of the system, either in pull-down or consumption times (**Key Stage 5**) (see results table 1, below).

It was also recognised that the thermal conductivity of plastic materials is
25 considerably lower than that of metals. The prototypes described thus far were formed from plastic with a conductivity value of around 1.4 W/mK whereas stainless steel is 16 W/mK. So, in order to assess how performance was affected by heat transfer, a prototype was made using a metal inner casing, surrounded by a 2mm layer of PCM, housed within a 4mm polyurethane foam insulation. (**Key
30 Stage 6**). Although the measurements obtained do not demonstrate a substantial performance improvement in comparison with its plastic counterpart, it should be noted that the dimensions of the two designs could not be matched precisely, and the steel-lined example had approximately 15% additional capacity. Thus, there

was additional heat energy to remove to achieve equivalent temperature. The conclusion is that steel is preferable to plastic for use as the heat transfer medium.

5 Results Table 1

Key Stage	Format	Time to Reach 70°C (minutes)		Duration 70 to 50°C (minutes)	
		Top	Bottom	Top	Bottom
1	Plastic Prototype No Lid				
	Control - Air Gap	10		26	
	PCM -Sodium Acetate 85ml	5		31	
2	Plastic Prototype + Non-insulated Lid				
	Control - Air Gap	22		50	
	PCM -Sodium Acetate 85ml	8		72	
3	Plastic Prototype + Insulated Lid				
	Control - Air Gap	59	56	96	94
	PCM -Sodium Acetate 85ml	21	8	136	138
4	Plastic Prototype + Insulated Lid with PCM				
	Control - PCM -Sodium Acetate 85ml	21	8	136	138
	PCM - Sodium Acetate 85ml +15ml lid	10	7	109	108
5	Plastic Prototype Reduced PCM + Insulated Lid with PCM				
	Control - PCM - Sodium Acetate 85ml +15ml lid	10	7	109	108
	PCM - Sodium Acetate 55ml + 15ml lid	11	12	120	114
6	Steel Prototype + Insulated Lid with PCM				
	Control -Plastic Prototype - PCM - Sodium Acetate 85ml +15ml lid	10	7	109	108
	PCM - Sodium Acetate 85ml +15ml lid	11	4	123	123

The various features and embodiments of the present invention, referred to in individual sections above apply, as appropriate, to other sections, *mutatis mutandis*. Consequently features specified in one section may be combined with features specified in other sections, as appropriate.

5

All publications mentioned in the above specification are herein incorporated by reference. Various modifications and variations of the described methods and products of the invention will be apparent to those skilled in the art without departing from the scope of the invention. Although the invention has been described in connection with specific preferred embodiments, it should be understood that the invention as claimed should not be unduly limited to such specific embodiments. Indeed, various modifications of the described modes for carrying out the invention which are apparent to those skilled in the relevant fields are intended to be within the scope of the following claims.

10

15

CLAIMS

1. A hot beverage receptacle comprising:
 - (i) an inner vessel with an upper open end, a closed lower end and a wall
5 connecting the upper and lower end;
 - (ii) an insulated outer shell;
 - (iii) a compartment disposed between the inner vessel and the outer shell
10 comprising a phase change material for absorbing thermal energy from a hot beverage in the inner vessel to cool the hot beverage and then releasing the thermal energy to the beverage to maintain the temperature of the cooled beverage; and
 - (iv) a lid for the open end of the vessel, which lid comprises a compartment
15 comprising a phase change material in the base of the lid, and an insulating layer.
2. A receptacle according to claim 1 wherein the compartment and phase
20 change material extend around substantially the entire inner vessel.
3. A receptacle according to claim 1 wherein the compartment and the phase
25 change material extend around the upper portion of the inner vessel only.
4. A receptacle according to any one of claims 1 to 3 wherein the phase
30 change material has a phase change temperature of from about 45°C to about 75°C.
5. A receptacle according to any one of claims 1 to 3 wherein the phase
change material has a phase change temperature of from about 50°C to about
70°C.
6. A receptacle according to any one of the preceding claims wherein the
phase change material comprises a crystalline salt, preferably sodium acetate
trihydrate.

7. A receptacle according to claim 6 wherein the phase change material further comprises a wax.

5 8. A receptacle according to any one of the preceding claims wherein the inner vessel is selected from stainless steel, aluminium, aluminium alloys, copper and copper alloys.

9. A receptacle according to any one of the preceding claims comprising a plurality of said compartments, each compartment being separated from the other
10 compartments.

10. A receptacle according to any one of the preceding claims wherein the lid includes an opening through which the hot beverage can be consumed.

15 11. A receptacle according to any one of the preceding claims wherein the insulating outer shell and/or insulating layer comprise a resilient foam.

12. A receptacle according to any one of the preceding claims in the form of a cup or a mug.

20 13. A receptacle for rapidly lowering the temperature of a hot beverage contained therein to a temperature suitable for human consumption and maintaining the beverage within a warm temperature range for an extended period of time, the receptacle comprising:

- 25 (i) an inner vessel with an upper open end, a closed lower end and a wall connecting the upper and lower end;
- (ii) an insulated outer shell;
- (iii) a compartment disposed between the inner vessel and the outer shell comprising a phase change material for absorbing thermal energy from a hot
30 beverage in the inner vessel to cool the hot beverage and then releasing the thermal energy to the beverage to maintain the temperature of the cooled beverage; and

(iv) a lid for the open end of the vessel, which lid comprises a phase change material in the base of the lid, and an insulating layer.

5 14. A receptacle according to claim 13 wherein lowering of the beverage from 90°C to 70°C at the top of the beverage occurs in less than 20 minutes.

15 15. A receptacle according to claim 13 or claim 14 wherein said warm temperature range is from about 45°C to about 75°C.

10 16. A receptacle according to claim 13 or claim 14 wherein said warm temperature range is from about 50°C to about 70°C.

17. A receptacle according to any one of claims 13 to 16 wherein said extended period of time is at least 90 minutes.

15

18. A receptacle according to any one of claims 13 to 17 as defined in any one of claims 2 to 12.

19. A container for hot food and drinks comprising:

20 (i) an inner vessel with an upper open end, a closed lower end and a wall connecting the upper and lower end;

(ii) an insulated outer shell;

(iii) a compartment disposed between the inner vessel and the outer shell comprising a phase change material for absorbing thermal energy from a hot foodstuff or drink in the inner vessel to cool the hot foodstuff or drink and then releasing the thermal energy to the foodstuff or drink to maintain the temperature of the cooled foodstuff or drink, wherein the compartment and the phase change material extend around the upper portion of the inner vessel only; and

25 (iv) a lid for the open end of the vessel, which lid comprises a compartment comprising a phase change material in the base of the lid, and an insulating layer.

30

20. A container according to claim 19 wherein the phase change material is in thermal contact with at least the upper third of the outer surface of the wall(s) of the inner vessel.

5 21. A container according to claim 19 or claim 20 wherein the phase change material is in thermal contact with at least 40% of the outer surface of the wall(s) of the inner vessel.

10 22. A container according to any one of claims 19 to 21 which is a cup or a mug.

23. A container for rapidly lowering the temperature of a hot foodstuff or drink contained therein to a temperature suitable for human consumption and maintaining the foodstuff or drink within a warm temperature range for an extended period of time, the container comprising:

- 15 (i) an inner vessel with an upper open end, a closed lower end and a wall connecting the upper and lower end;
- (ii) an insulated outer shell;
- 20 (iii) a compartment disposed between the inner vessel and the outer shell comprising a phase change material for absorbing thermal energy from a hot foodstuff or drink in the inner vessel to cool the hot foodstuff or drink and then releasing the thermal energy to the foodstuff or drink to maintain the temperature of the cooled foodstuff or drink, wherein the compartment and the phase change material extend around the upper portion of the inner vessel only; and
- 25 (iv) a lid for the open end of the vessel, which lid comprises a phase change material in the base of the lid, and an insulating layer.

24. A receptacle or container substantially as hereinbefore defined with reference to the drawings.

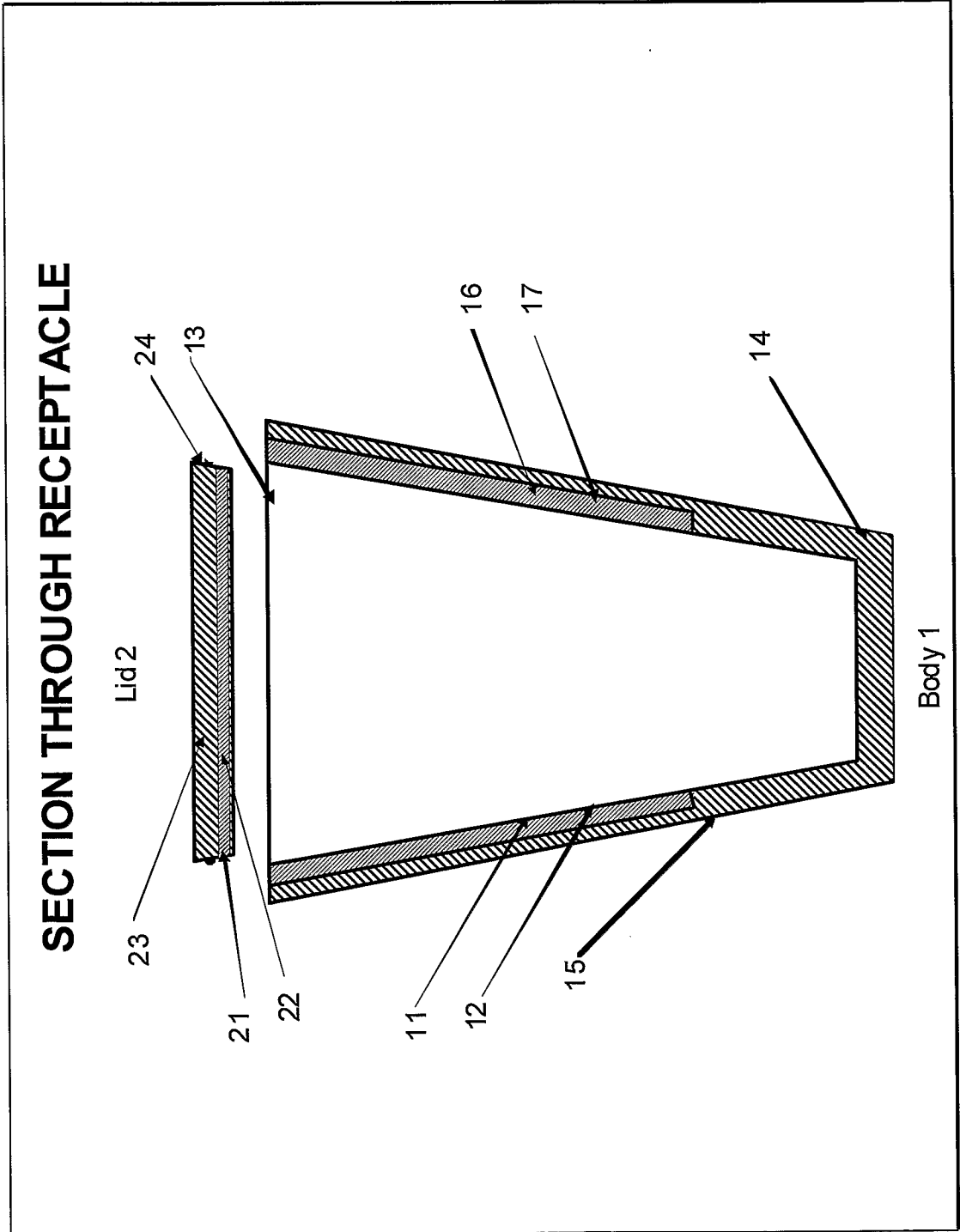

Figure 1

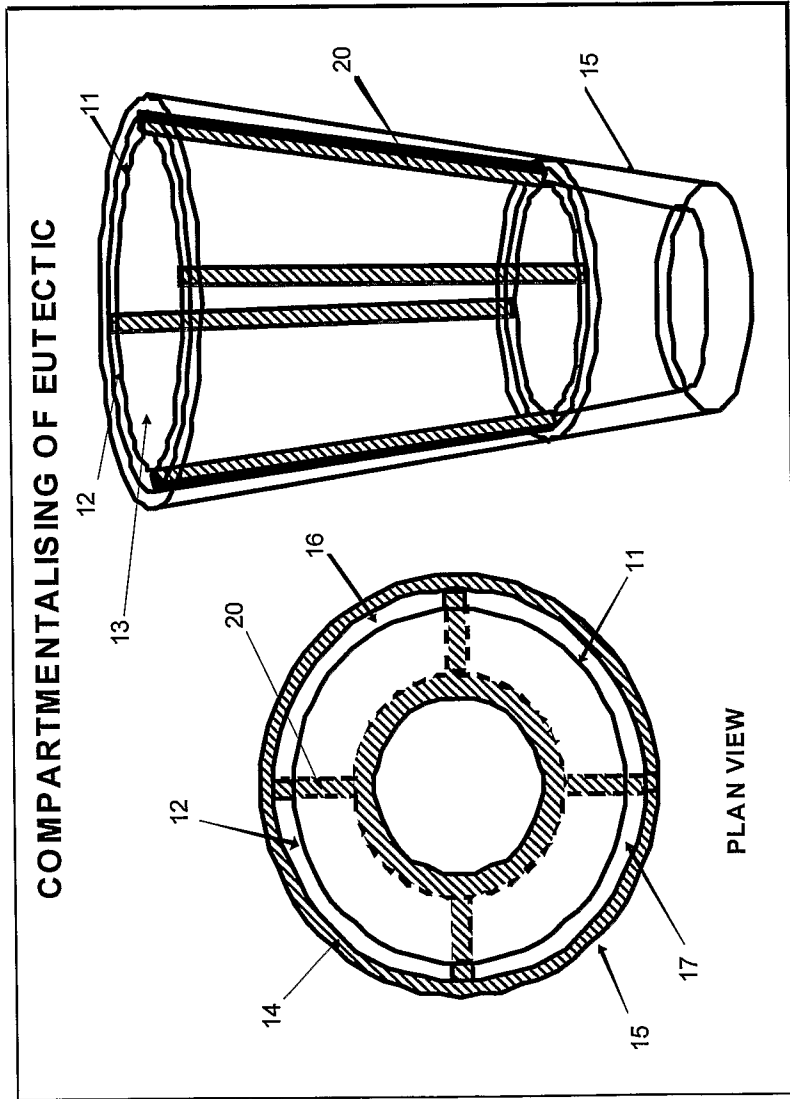

Figure 2

Beverage Temperature Histories

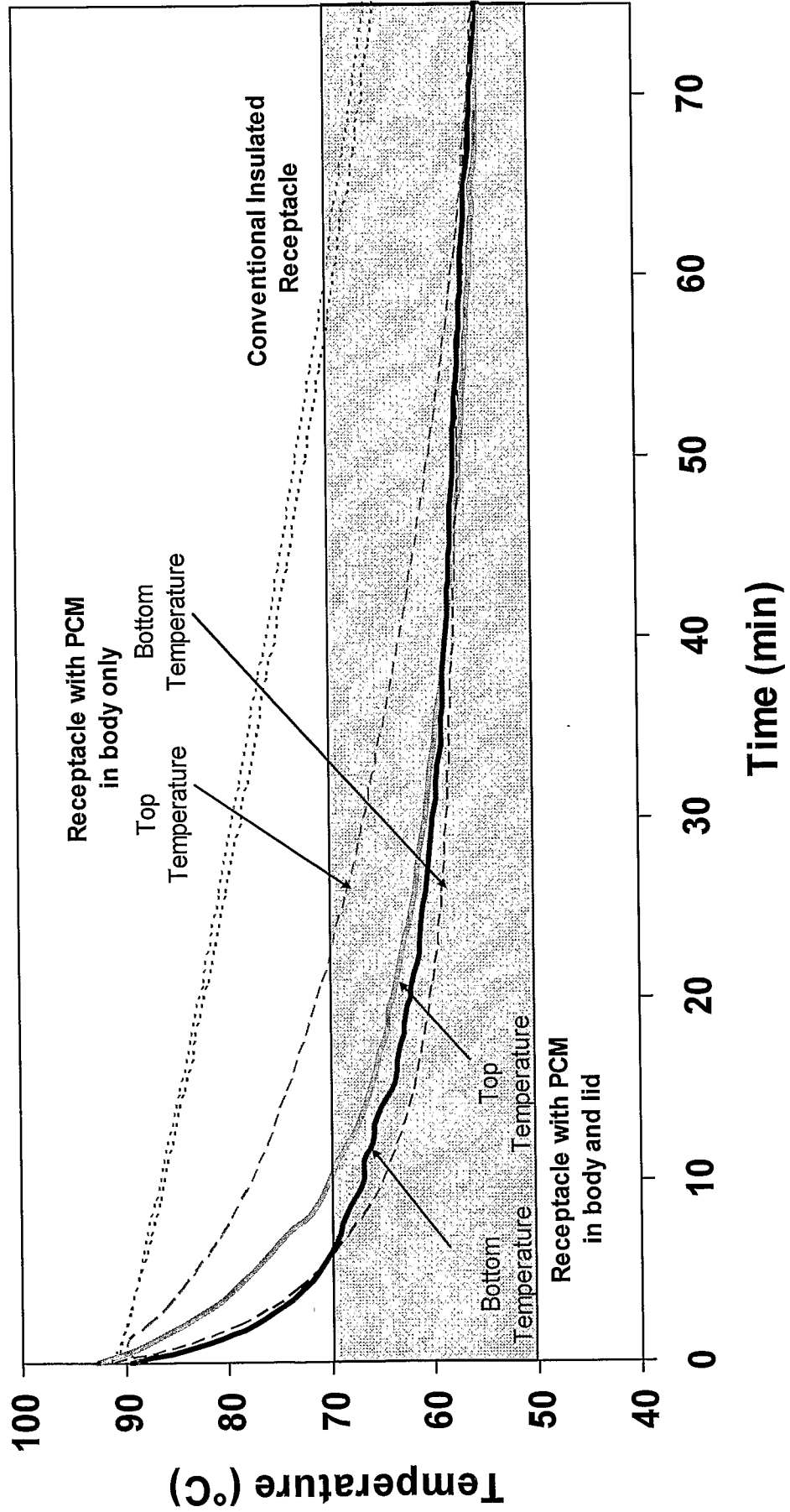

Figure 3

INTERNATIONAL SEARCH REPORT

International application No
PCT/GB2008/000715

A. CLASSIFICATION OF SUBJECT MATTER

INV. A47G19/12 A47G19/22 A47J41/00 B65D81/38 C09K5/06
B65D1/26 B65D25/04

According to International Patent Classification (IPC) or to both national classification and IPC

B. FIELDS SEARCHED

Minimum documentation searched (classification system followed by classification symbols)

A47G A47J B65D C09K

Documentation searched other than minimum documentation to the extent that such documents are included in the fields searched

Electronic data base consulted during the international search (name of data base and, where practical, search terms used)

EPO-Internal

C. DOCUMENTS CONSIDERED TO BE RELEVANT

Category*	Citation of document, with indication, where appropriate, of the relevant passages	Relevant to claim No.
X Y	US 5 052 369 A (JOHNSON KENDRICK A [US]) 1 October 1991 (1991-10-01) column 2, line 25 - column 8, line 26 -----	1, 2, 7, 12, 13, 24 3-6, 8-11, 14-23
Y	US 6 968 888 B2 (KOLOWICH J BRUCE [US]) 29 November 2005 (2005-11-29) cited in the application column 4, line 4 - column 8, line 57 -----	3-5, 8, 11, 14-23
Y	WO 97/24968 A (THERMAL ENERGY ACCU PROD PTY [AU]; MURPHY PETER LAWRENCE [AU]; SOLOMON) 17 July 1997 (1997-07-17) page 5, lines 8-13 ----- -/--	6

Further documents are listed in the continuation of Box C.

See patent family annex.

* Special categories of cited documents :

A document defining the general state of the art which is not considered to be of particular relevance

E earlier document but published on or after the international filing date

L document which may throw doubts on priority claim(s) or which is cited to establish the publication date of another citation or other special reason (as specified)

O document referring to an oral disclosure, use, exhibition or other means

P document published prior to the international filing date but later than the priority date claimed

T later document published after the international filing date or priority date and not in conflict with the application but cited to understand the principle or theory underlying the invention

X document of particular relevance; the claimed invention cannot be considered novel or cannot be considered to involve an inventive step when the document is taken alone

Y document of particular relevance; the claimed invention cannot be considered to involve an inventive step when the document is combined with one or more other such documents, such combination being obvious to a person skilled in the art.

Z document member of the same patent family

Date of the actual completion of the international search

5 May 2008

Date of mailing of the international search report

14/05/2008

Name and mailing address of the ISA/

European Patent Office, P.B. 5818 Patentlaan 2
NL - 2280 HV Rijswijk
Tel. (+31-70) 340-2040, Tx. 31 651 epo nl,
Fax: (+31-70) 340-3016

Authorized officer

Jervelund, Niels

INTERNATIONAL SEARCH REPORT

International application No

PCT/GB2008/000715

C(Continuation). DOCUMENTS CONSIDERED TO BE RELEVANT

Category*	Citation of document, with indication, where appropriate, of the relevant passages	Relevant to claim No.
Y	US 4 955 503 A (PROPE MICHAEL L [US]) 11 September 1990 (1990-09-11) figures 1,2 -----	9,10
A	US 4 460 103 A (RAMA LORD [US] ET AL) 17 July 1984 (1984-07-17) figures 3,4 -----	10
A	US 2 876 634 A (ZIMMERMAN HALE G ET AL) 10 March 1959 (1959-03-10) cited in the application column 1, line 70 - column 2, line 9 -----	1-24
A	WO 98/45208 A (KOLOWICH J BRUCE [US]) 15 October 1998 (1998-10-15) cited in the application figures 1-4 -----	1-24

INTERNATIONAL SEARCH REPORT

Information on patent family members

International application No

PCT/GB2008/000715

Patent document cited in search report	Publication date	Patent family member(s)	Publication date
US 5052369	A	01-10-1991	NONE
US 6968888	B2	29-11-2005	US 2004083755 A1 06-05-2004
WO 9724968	A	17-07-1997	NONE
US 4955503	A	11-09-1990	NONE
US 4460103	A	17-07-1984	NONE
US 2876634	A	10-03-1959	NONE
WO 9845208	A	15-10-1998	AU 6893398 A 30-10-1998 US 6634417 B1 21-10-2003