

9902  
X-9919

June 1, 1937.

H. L. PATTON

2,082,216

FIRE EXTINGUISHING APPARATUS AND METHOD

Filed Aug. 27, 1936

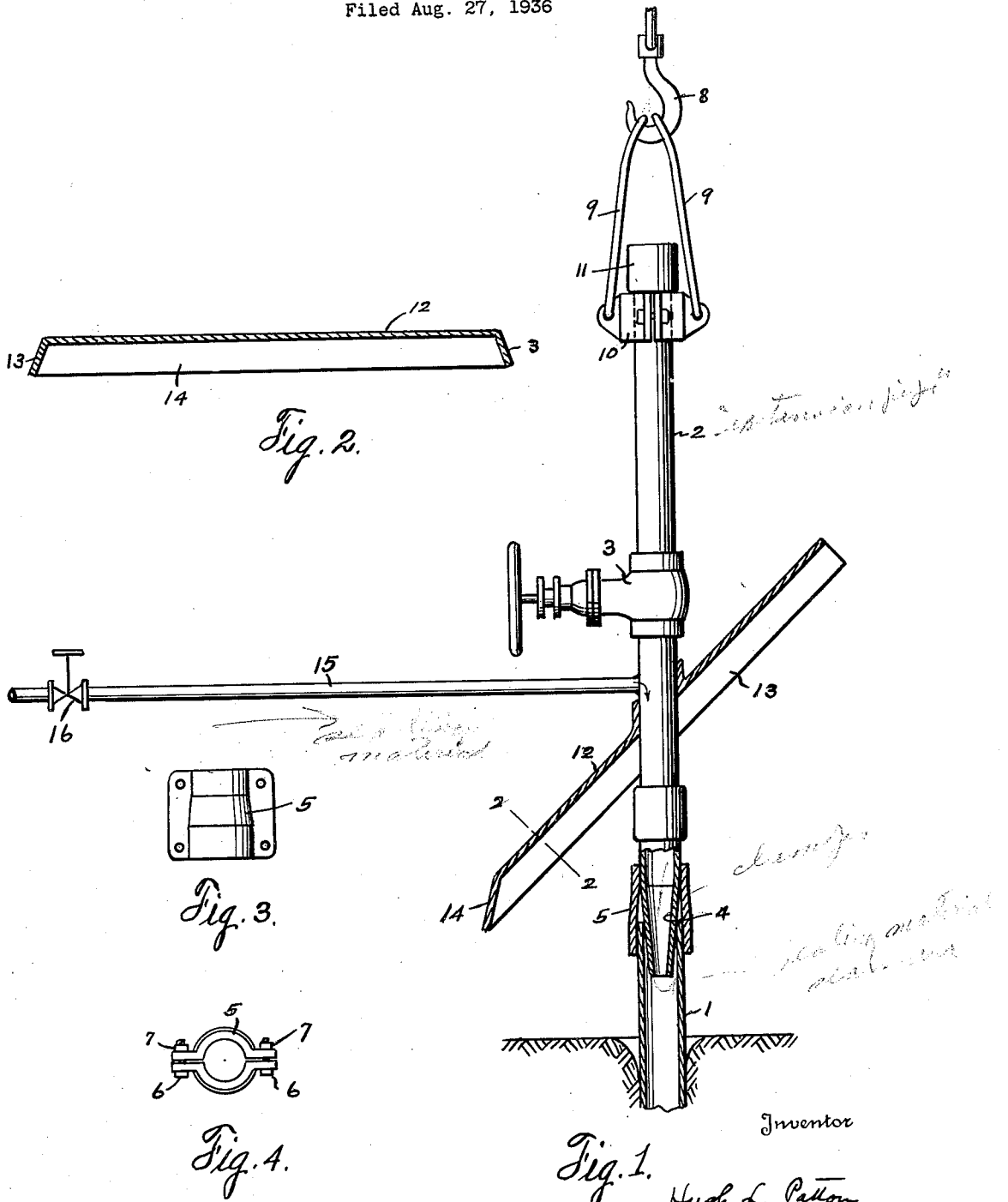

Fig. 2.

Fig. 3.

Fig. 4.

Fig. 1.

Inventor

Hugh L. Patton

Edward V. Handway  
Attorney

By

Patented June 1, 1937

2,082,216

## UNITED STATES PATENT OFFICE

2,082,216

## FIRE EXTINGUISHING APPARATUS AND METHOD

Hugh L. Patton, Houston, Tex.

Application August 27, 1936, Serial No. 98,196

11 Claims. (Cl. 166—15)

This invention relates to fire extinguishing apparatus and has particular relation to apparatus of the character described specially adapted for use in extinguishing oil or gas well fires.

5 An object of the invention is to provide apparatus that may be readily connected to the upper end of the pipe in the well and which is provided with a novel type of shield which will shield the workmen during the preliminary steps of connecting the apparatus to the well pipe.

10 Another object of the invention is to provide apparatus of the character described comprising an extension pipe having a shield thereon and whose lower end is shaped to be telescoped with the well pipe and anchored thereto with a valve for controlling the extension pipe and with means for forcing a sealing means through the extension pipe into the well pipe whereby a fluid tight seal may be formed between them.

20 The invention also comprehends a novel method of controlling a well.

With the above and other objects in view, the invention has particular relation to certain novel features of construction, operation and arrangement of parts, an example of which is given in this specification and illustrated in the accompanying drawing, wherein:—

Figure 1 shows a side view of the apparatus partly in section as connected to a well pipe.

30 Figure 2 shows a sectional view of the shield, taken on the line 2—2 of Figure 1.

Figure 3 shows a side view of one of the jaws of a clamp employed, and

Figure 4 shows an end view of the clamp.

35 Referring now more particularly to the drawing wherein like numerals of reference designate similar parts in each of the figures, the numeral 1 designates a pipe set in a well bore. It is a well known fact that the oil or gas flowing from a well, particularly when it flows under high pressure, often becomes ignited. Under such conditions it is very difficult to extinguish the fire, particularly when the fluid flowing from the well is flowing under high pressure. Intense heat is generated making it very hazardous for a workman to approach the well near enough to do effective work toward extinguishing the fire. If the fire is extinguished and the flowing fluid is not placed under control, said fluid will again likely become ignited causing another fire. The apparatus hereinafter described is effective not only to protect the workman while accomplishing the initial work but is also effective to extinguish the fire and place the well under control. To that end the extension pipe 2 is pro-

vided having the control valve 3 therein. The lower end 4 of this extension pipe is shaped to telescope with the upper end of the well pipe 1. It is preferably swaged or downwardly tapered as shown in Figure 1 to fit within the pipe 1. When brought into telescoping relation with the well pipe a clamp formed of the arcuate jaws 5, 5 may be fitted around the telescoping ends of said pipes. The ends of these jaws are outwardly turned and bolts 6, 6 may be fitted through said ends and secured in place in the usual way by the nuts 7.

The extension pipe may be swung into place over the well pipe by any suitable equipment designed for the purpose, preferably by means of a swinging boom of well known construction from which a hook 8 is suspended, said hook being engaged through the bails 9, 9 of the elevator 10 which is latched around the extension pipe 2 underneath the coupling 11 which is screwed on 20 the upper end thereof.

The extension pipe 2 is swung over the well while the well is burning and is then lowered into telescopic relation with the upper end of the pipe 1. In order to protect the workmen from intense heat, a shield 12 is secured around the extension pipe preferably beneath the valve 3 thereof. This shield is arranged in angular relation with the pipe 2, the angle being about forty five degrees.

30 The underside of the shield is channel shaped, that is, the shield has the depending side flanges 13 connected by the depending lower end flange 14. The upper end of the channel thus formed is left open. The workmen accordingly operate behind this shield, and the shield will collect the rising ignited fluid and divert the same off laterally away from the location where the workmen are operating. At this time the valve 3 is open and when the extension pipe 2 is lowered into telescoping relation with the well pipe 1, the well fluid will pass up through the extension pipe so that the flame will be at the top of the extension pipe, a sufficient distance to permit the workmen to approach the well and to secure the jaws 5 in place.

45 Leading into the extension pipe beneath the valve 3 there is a line 15 which is controlled by the valve 16. A sealing material in fluid form, may be forced through the line 15 and downwardly through the extension pipe into the well pipe 1, and this sealing material will be carried upwardly between the tapered portion 4 and the pipe 1 and will collect therein and seal any leaks 55

that may exist between said pipes. The valve 16 may then be closed.

Additional securing means may be employed for securing the extension pipe to the well pipe 5 1 such as are now commonly used for similar purposes.

The valve 3 may now be closed and the fuel cut off from the flame and the fire thereby extinguished and the well placed under control.

10 The drawing and description disclose what is now considered a preferred form of the invention, by way of illustration only, while the broad principle of the invention will be defined by the appended claims.

15 What I claim is:

1. Apparatus for controlling the flow of fluid from a well and comprising an extension pipe adapted to be connected to the upper end of a well pipe, a channel shaped deflector forming 20 a shield secured to and surrounding the extension pipe in angular relation thereto and a valve for controlling the extension pipe.

2. Fire extinguishing apparatus for wells comprising an extension pipe, a valve controlling said extension pipe, an inverted, channel shaped 25 deflecting shield on, and arranged in angular relation to, the extension pipe.

3. Fire extinguishing apparatus for wells comprising an extension pipe adapted to be connected to the upper end of the well pipe, means for forming said connection, a shield secured on the extension pipe and disposed in diagonal relation thereto and a valve controlling the extension pipe.

35 4. Apparatus of the character described comprising an extension pipe, a valve for controlling the passage of fluid through the pipe, a shield disposed diagonally on the pipe and extending out laterally in all directions therefrom, and 40 means for connecting the lower end of the pipe to the upper end of the well.

5. Fire extinguishing apparatus comprising a tubular extension pipe whose lower end is shaped to be connected to the upper end of a 45 well pipe, a valve for controlling the passage of fluid through the extension pipe, a shield on the extension pipe having depending side flanges and a depending lower end flange and whose underside is thus channel shaped.

50 6. The method of controlling a well from which fluid is flowing under pressure comprising lowering a tubular conducting member over the well, diverting the liquid, issuing from the well,

in a predetermined direction laterally during the lowering operation, fastening said member to the top of the well to form an extension thereof.

7. The method of controlling a well from which fluid is flowing under pressure comprising 5 lowering a tubular conducting member over the well, diverting the liquid, issuing from the well, in a selected direction laterally during the lowering operation, fastening said member to the top of the well to form an extension thereof, 10 then closing the conducting member.

8. The method of extinguishing a well fire and controlling a well from which fluid is flowing under pressure which method comprises lowering a tubular extension member onto the upper 15 end of the well pipe, the entire volume of flowing liquid laterally and upwardly in a selected direction while the extension member is being lowered and fastening said member to the well pipe. 20

9. The method of extinguishing a well fire and controlling a well from which fluid is flowing under pressure which method comprises lowering a tubular extension member onto the upper 25 end of the well pipe, diverting all of the flowing liquid laterally and upwardly while the extension member is being lowered and fastening said member to the well pipe then closing said extension member.

10. The method of extinguishing a well fire 30 and controlling a well from which fluid is flowing under pressure which method comprises lowering a tubular extension member onto the upper end of the well pipe, diverting the flowing liquid in a selected direction laterally and upwardly while the extension member is being lowered and fastening said member to the well pipe then closing said extension member, and forcing 35 a sealing substance down through the extension member into the well pipe. 40

11. A fire extinguishing apparatus for use on oil and gas wells and comprising a tubular extension pipe whose lower end is shaped to be connected to the upper end of a well pipe, a valve for controlling the passage of fluid through 45 the extension pipe, a diagonal shield on, and extending each way from, the extension pipe, said shield being of sufficient dimensions to divert all of the liquid issuing from the well laterally and upwardly in a selected direction to provide a safety zone to permit workmen to approach the vicinity of the well. 50

HUGH L. PATTON.