

Oct. 25, 1949.

J. H. ROGERS

2,485,777

CARPENTER'S CALCULATING DEVICE

Filed June 28, 1946

*Fig. 1.*

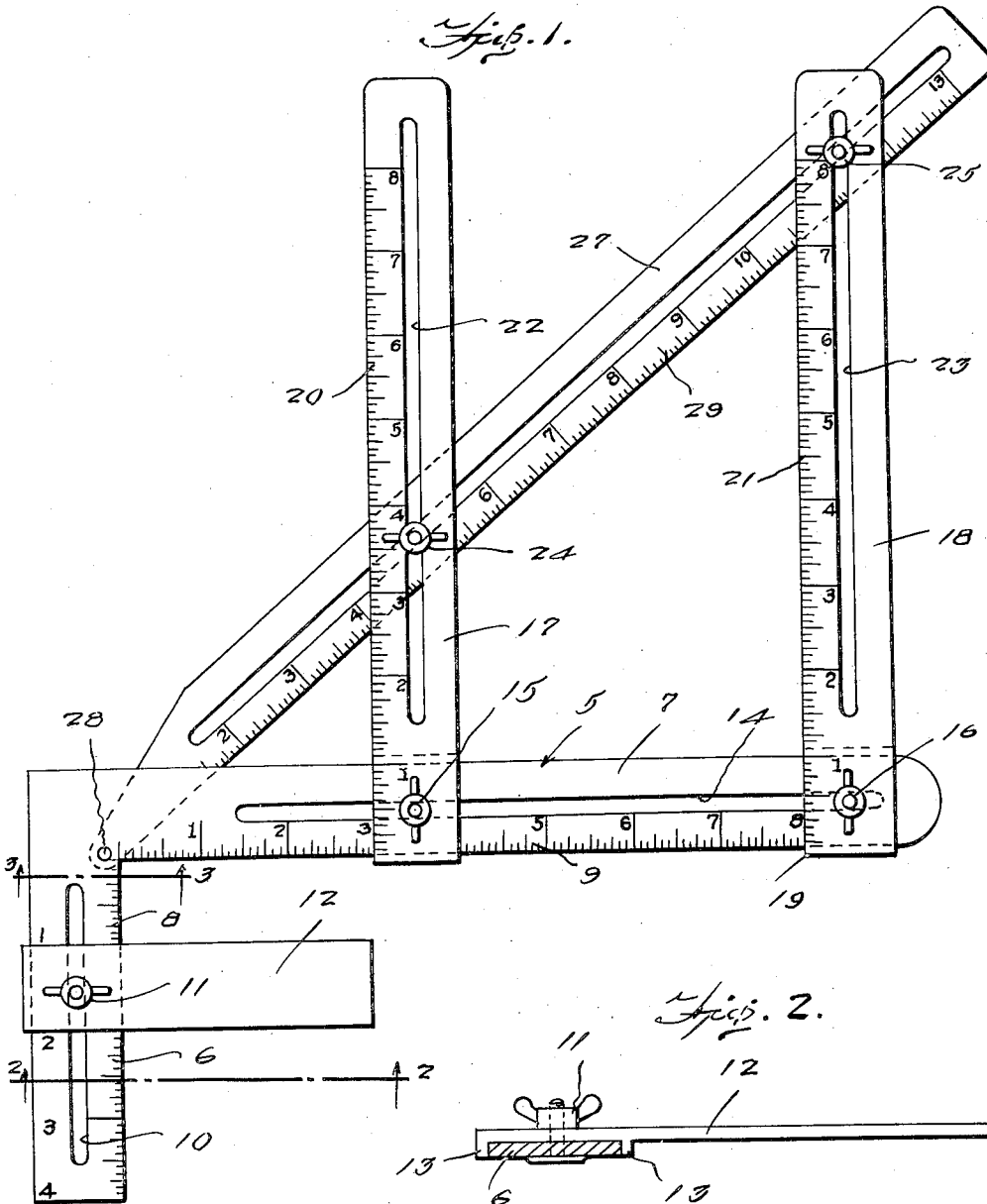

*Fig. 2.*

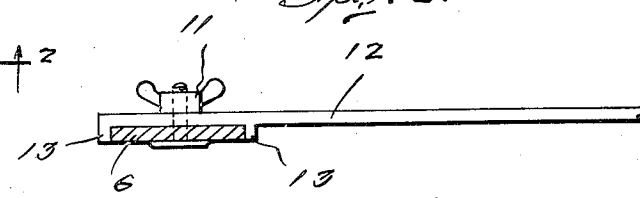

*Fig. 3.*

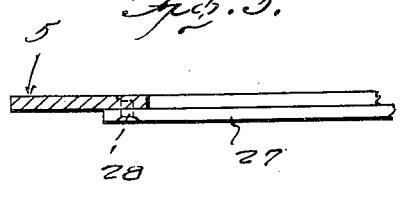

Inventor  
*James H. Rogers*

*By* *McMorris, Berman & Davidson*  
Attorneys

# UNITED STATES PATENT OFFICE

2,485,777

## CARPENTER'S CALCULATING DEVICE

James H. Rogers, Neosho, Mo., assignor to Polly  
Delphia Jane Rogers Contreras, Newton  
County, Mo.

Application June 28, 1946, Serial No. 680,118

2 Claims. (Cl. 33-97)

1

The present invention relates to new and useful improvements in calculating devices for use by carpenters, draftsmen, and others, whereby the rise of roof rafters, or the pitch or angle of other structural elements may be easily, quickly and accurately computed.

An important object of the present invention is to provide a calculating device of this character which may also be used for laying out and computing the angle by a draftsman on a drawing board.

Another object of the invention is to provide a device of this character in which the parts are mounted for convenient adjustment and for easy and quick assembly and disassembly to store or carry the device in a compact form.

A further object is to provide a device of this character of simple and practical construction, which is strong and durable, efficient and reliable in use, and otherwise well adapted for the purposes for which the same is intended.

Other objects and advantages reside in the details of construction and operation as more fully hereinafter described and claimed, reference being had to the accompanying drawings forming part hereof, wherein like numerals refer to like parts throughout, and in which:

Figure 1 is a plan view.

Figures 2 and 3 are sectional views taken respectively on the lines 2-2 and 3-3 of Figure 1.

Referring now to the drawings in detail, wherein for the purpose of illustration I have disclosed a preferred embodiment of the invention, the numeral 5 designates a carpenter's square generally which is preferably constructed of relatively thin light weight rigid metal and includes a leg member 6, an arm member 7 connected to each other at one end and extending at right angles to each other, the arm member 7 being substantially longer than the leg member 6.

The inner edge of the leg member 6 is marked with a scale 8 graduated in inches and fractions thereof, and the inner edge of the arm member 7 is provided with a similar scale 9.

The leg member 6 is formed with a longitudinally extending slot 10 in which a bolt and wing nut 11 is slidably received, the bolt and wing nut being carried at the inner end of a relatively short arm 12 which projects laterally from the leg 6 in parallelism with the arm 7, and is adjustable toward and away from the arm 7. The under side of the arm 12 is provided with a pair of spaced-apart guide flanges 13 engaging the opposite edges of the leg 6 to maintain the arm 12

2

in a true right angle position with respect to the leg.

The arm 7 is also formed with a longitudinally extending slot 14 for slidably receiving bolts and wing nuts 15 and 16 carried at the inner ends, respectively, of a pair of slide arms 17 and 18 which extend at right angles to the arm 7 and project laterally from the outer edge of the arm 7 and with the slide arms 17 and 18 in parallelism to each other.

The inner ends of the arms 17 and 18 are bent upon themselves or otherwise constructed to form slides 19 embracing and slidably receiving the arm 7.

The edges of the sliding arms 17 and 18 nearest the inner end of the arm 7 are formed with scales 20 and 21, respectively, also graduated in inches and fractions thereof.

The arms 17 and 18 are also formed with longitudinally extending slots 22 and 23, respectively, in which bolts and wing nuts 24 and 25 are slidably received and which are also slidably received in a longitudinally extending slot 26 formed in a pivoted arm 27. The inner end of the pivoted arm 27 is pivoted to the square 5 by means of a pin or the like 28 which is positioned at the corner of the inner edges of the leg 6 and arm 7.

The arm 27 is pivoted adjacent one longitudinal edge which is also provided with a scale 29 graduated in inches and fractions thereof.

From the foregoing it will be apparent that the pivoted arm 27 may swing toward or away from the arm 7 of the square 5 and is secured in its inclined position by the bolts and wing nuts 24 and 25. The sliding arms 17 and 18 are likewise adjustable longitudinally on the arm 7 and secured in their adjusted positions by the bolts and wing nuts 15 and 16. Accordingly, the angle or pitch of roof rafters or other structural elements may be computed by adjusting the arms in a manner as will be apparent.

The arm 18 is used to hold the pivoted arm 27 in its adjusted position to estimate the rise.

Arm 17 is attached in position, as shown in Figure 1, principally in cutting stair runs or gable boxing and gable studding, and is attached to arm 7 before setting the gauge for the run of arm 18. Arm 17 is slidably adjusted on the arm 7 to determine the proper distance between studding and for other purposes.

The arm 12 is a slide scale attached to leg 6 for use in cutting heel cuts of rafters to fit on plate. The arm 12 is adjusted to cut a desired depth in the heel of the rafter, using the instrument to scribe the desired cut as to any desired

3

pitch which would change the position of the heel cut according to the pitch. Arm 12 is adjusted vertically on leg 6 to correspond to the depth of cut desired in the heel of the rafter.

It is believed that the details of construction, manner of use and advantages of the device will be readily understood from the foregoing without further detailed explanation.

It is to be understood, however, that even though I have herein shown and described a preferred embodiment of my invention, the same is susceptible of certain changes fully comprehended by the spirit of the invention as herein described, and the scope of the appended claims.

Having thus described my invention, what I claim is:

1. In a carpenter's framing tool including an elongated arm member, a slide arm connected at one end to said arm member for adjustable movement lengthwise of the latter, said arm member and slide arm being perpendicular to each other, and a pivotal arm pivotally connected at one end to said arm member adjacent one end of the latter and adjustably connected to said slide arm for indicating the pitch and run of a rafter when the base and rise are known, means comprising a leg at the end of said arm member at which said pivoted arm is pivotally connected, said leg extending perpendicularly from the side of said arm member opposite the side from which said slide arm extends, and a short arm secured at one end to said leg for sliding movement lengthwise of the latter, said short arm extending from said leg in the same direction and parallel to said arm member.

2. In a carpenter's framing tool including an elongated arm member, a slide arm connected at one end to said arm member for adjustable movement lengthwise of the latter, said arm

4

member and slide arm being perpendicular to each other, and a pivotal arm pivotally connected at one end to said arm member adjacent one end of the latter and adjustably connected to said slide arm for indicating the pitch and run of a rafter when the base and rise are known, means for laying out plate-receiving notches in rafters comprising a leg at the end of said arm member at which said pivoted arm is pivotally connected, said leg extending perpendicularly from the side of said arm member opposite the side from which said slide arm extends, and a short arm secured at one end to said leg for sliding movement lengthwise of the latter, said short arm extending from said leg in the same direction and parallel to said arm member, said leg having a scale along one edge thereof and a longitudinally-extending slot therein, said short arm having parallel guide flanges thereon contacting the opposite edges of said leg and an aperture therein registering with the slot in said leg, and a thumb screw extending through said slot and said aperture adjustably securing said short arm to said leg.

JAMES H. ROGERS.

#### REFERENCES CITED

The following references are of record in the file of this patent:

#### UNITED STATES PATENTS

Number	Name	Date
115,318	Hickmann	May 30, 1871
735,128	Murphy	Aug. 4, 1903
875,045	Brown	Dec. 31, 1907

#### FOREIGN PATENTS

Number	Country	Date
295,819	Great Britain	Aug. 23, 1926