

(19) World Intellectual Property Organization  
International Bureau



(43) International Publication Date  
7 February 2002 (07.02.2002)

PCT

(10) International Publication Number  
**WO 02/10839 A1**

(51) International Patent Classification<sup>7</sup>: **G02B 27/40**,  
27/64, 7/04

H.; 17765 Elaine Court, Morgan Hill, CA 95037 (US).  
**KINO, Gordon, S.**; 867 Cedro Way, Stanford, CA 94305  
(US).

(21) International Application Number: PCT/US01/21029

(22) International Filing Date: 3 July 2001 (03.07.2001)

(74) Agent: **ALBOSZTA, Marek**; Lumen, 45 Cabot Avenue,  
Suite 110, Santa Clara, CA 95051 (US).

(25) Filing Language: English

(81) Designated States (*national*): CA, JP.

(26) Publication Language: English

(84) Designated States (*regional*): European patent (AT, BE,  
CH, CY, DE, DK, ES, FI, FR, GB, GR, IE, IT, LU, MC,  
NL, PT, SE, TR).

(30) Priority Data:  
09/628,118 28 July 2000 (28.07.2000) US

(71) Applicant: **OPTICAL BIOPSY TECHNOLOGIES,  
INC.** [US/US]; 2088-A Walsh Avenue, Santa Clara, CA  
95050 (US).

Published:  
— with international search report

(72) Inventors: **MANDELLA, Michael, J.**; 10193 Parkwood  
Drive #2, Cupertino, CA 95014 (US). **GARRETT, Mark,**

For two-letter codes and other abbreviations, refer to the "Guid-  
ance Notes on Codes and Abbreviations" appearing at the begin-  
ning of each regular issue of the PCT Gazette.

(54) Title: FIBER-COUPLED, HIGH-SPEED, INTEGRATED, ANGLED-DUAL-AXIS CONFOCAL SCANNING MICRO-  
SCOPES EMPLOYING VERTICAL CROSS-SECTION SCANNING

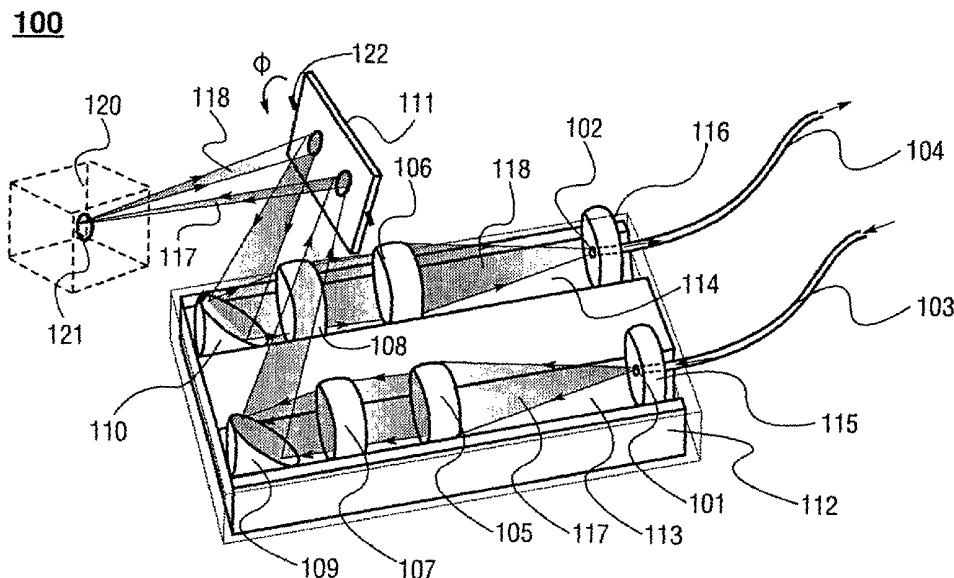

(57) Abstract: This invention provides an angled-dual axis confocal scanning microscope (Fig. 1A) comprising a fiber-coupled (103 and 104), angled-dual-axis confocal scanning head (100) and a vertical scanning unit (111). The angled-dual-axis confocal scanning head is configured such that an angle within an object (120) and the scanning is achieved by pivoting the illumination and observation beams using a single scanning element, thereby producing an arc-line scan (121).



WO 02/10839 A1

**FIBER-COUPLED, HIGH-SPEED, INTEGRATED,  
ANGLED-DUAL-AXIS CONFOCAL SCANNING MICROSCOPES  
EMPLOYING VERTICAL CROSS-SECTION SCANNING**

5

CROSS-REFERENCE TO RELATED APPLICATIONS

This application is related to the following copending U.S. Patent Applications, all of which are herein incorporated by reference: "Fiber-coupled, High-speed, Angled-Dual-Axis Optical  
10 Coherence Scanning Microscopes" of Michael J. Mandella, Mark H. Garrett, and Gordon S. Kino, US patent application No. 09/628,119; and "Fiber-coupled, Angled-Dual-Axis Confocal Scanning Microscopes for Imaging in a Scattering Medium" of Michael J. Mandella, Mark H. Garrett, and Gordon S. Kino, US  
15 application No. 09/627,363.

FIELD OF THE INVENTION

This invention relates generally to the field of confocal microscopes, and in particular, to a new class of fiber-  
20 coupled, angled-dual-axis confocal scanning microscopes with integrated structure, enhanced resolution, low noise, and vertical cross-section scanning.

BACKGROUND ART

25 The advent of fiber optics and laser technology has brought a renewed life to many areas of conventional optics. Confocal microscopes, for example, have enjoyed higher resolution, more integrated structure, and enhanced imaging capability. Consequently, confocal microscopes have become increasingly  
30 powerful tools in a variety of applications, including biological and medical imaging, optical data storage and industrial applications.

The original idea of confocal microscopy traces back to the  
35 work of Marvin Minsky. Described in his seminal US patent 3,013,467 is a system in which an illumination beam passes through a pinhole, traverses a beamsplitter, and is focused by an objective to a focal volume within an object. An

observation beam that emanates from the focal volume is in turn converged by the same objective lens, reflected by its second encounter with the beamsplitter, and passes through a second pinhole to an optical detector. The geometry of this confocal arrangement is such that only the light beam originating from the focal volume is able to pass through the second pinhole and reach the optical detector, thus effectively discriminating all other out-of-focus signals.

10 Contemporary confocal microscopes tend to adopt one of two basic confocal geometries. In the transmission arrangement using two objectives, one objective focuses an illumination beam from a point source onto a focal volume within an object and another objective collects an observation beam that emanates from the focal volume. Whereas in the so-called "reciprocal" reflection arrangement, a single objective plays a dual role of focusing light on the object and collecting the light emanated from the object. In either case, the confocal arrangement enables the confocal microscope to attain a higher resolution and sharper definition than a conventional microscope, because out-of-focus signals are rejected. This unique ability has made confocal microscopes particularly useful tools in the examination of biological specimens, since they can view a specific layer within a sample and avoid seeing other layers, the so-called "optical sectioning".

In order to image a thin layer about a few micrometers thick within a sample, however, the numerical aperture (NA) of the objective lenses must be large, so as to provide adequate resolution particularly in the axial direction. This generally results in a short working distance, which is undesirable in practice. Moreover, when imaging within tissue or scattering media, the signal is typically dominated by scattering from points far away from the focus of the large NA objective, thus resulting in noisy (low contrast) images.

A great deal of ingenuity has accordingly been devoted to improving the axial resolution of confocal microscopes without

using high NA lenses. A particularly interesting approach is to spatially arrange two separate illumination and observation objective lenses, or illumination and observation beam paths, in such a way that the illumination beam and the observation beam intersect at an angle  $\theta$  at the focal points, so that the overall point-spread function for the microscope, i.e., the overlapping volume of the illumination and observation point-spread functions results in a substantial reduction in the axial direction. A confocal microscope with such an angled, dual-axis design is termed a confocal theta microscope, or an angled-dual-axis confocal microscope, hereinafter. Its underlying theory is stated below for the purpose of elucidating the principle of this invention. A more detailed theory of confocal theta microscopy can be found in US Patent 5,973,828; by Webb et al. in "Confocal microscope with large field and working distance", Applied Optics, Vol.38, No.22, pp.4870; and by Stelzer et al. in "A new tool for the observation of embryos and other large specimens: confocal theta fluorescence microscopy", Journal of Microscopy, Vol.179, Part 1, pp. 1; all incorporated by reference.

The region of the point-spread function of a microscope's objective that is of most interest is the region in which the point-spread function reaches its maximum value. This region is referred to as the "main lobe" of the point-spread function in the art. It is typically characterized in three dimensions by an ellipsoid, which extends considerably further in the axial direction than in the transverse direction. This characteristic shape is the reason that the axial resolution is inherently poorer than the transverse resolution in a conventional confocal microscope. When the main lobes of the illumination and observation point-spread functions are arranged to intersect at an angle in a confocal theta microscope, however, a predominantly transverse and therefore narrow section from one main lobe is made to multiply (i.e., zero out) a predominantly axial and therefore long section from the other main lobe. This optimal multiplication of the two point-spread functions reduces the length of the axial section

of the overall point-spread function, thereby enhancing the overall axial resolution. The shape of the overall point-spread function can be further adjusted by varying the angle at which the main lobes of the illumination and observation point-spread functions intersect.

The past few years have seen a few confocal theta microscopes with similar designs in the art. For example, Stelzer et al. describe the theory of confocal theta microscopy with two and three objective high NA lenses and an angle of  $\theta = 90^\circ$  in "Fundamental reduction of the observation volume in far-field light microscopy by detection orthogonal to the illumination axis: confocal theta microscopy", Optics Communications 111, pp.536. German Patent DE-OS 43 26 473 A1 demonstrates a confocal theta microscope in which the axes of two high NA objective lenses are oriented at a right angle ( $\theta = 90^\circ$ ). It also discloses a confocal theta microscope with three high NA objective lenses, in which the axes of two objectives are perpendicular to each other, while the axis of the third objective lies on the axis of one of the other two objectives. The patent does not disclose how scanning is carried out in these confocal theta microscopes. Although scanning might be performed by translating the object to be examined in such systems, the designs of these confocal theta microscopes are such that they do not appear to readily accommodate scanning that probes into the interior of the object. US Patent 5,969,854 discloses a confocal theta microscope with the axes of two high NA objective lenses positioned at an angle approximately  $90^\circ$ . This system incorporates a scanning mechanism that translates the object for imaging purposes.

Webb et al. describe a confocal scanning microscope with angled objective lenses that have relatively low NA in "Confocal microscope with large field and working distance", Applied Optics, Vol.38, No.22, pp.4870. The design of this microscope attains usable resolutions for biological applications in both transverse and axial directions, while achieving a large field of view and a long working distance. The scanning in this case

is achieved by moving a stage on which the object is mounted. US Patent 5,973,828 discloses a confocal theta scanning microscope in which the axes of two objective lenses intersect at a variable angle  $\theta$ . Two-dimensional scanning is achieved by steering the illumination and observation beams in the back focal plane of the objective lenses to provide scanning in one direction, and by separately moving and coordinating the illumination and observation lenses to bring about overlap of the focal volumes during scanning in the other direction. It is disclosed that without such coordination the overlap cannot be maintained throughout the scanning. US Patent 6,064,518 describes a confocal theta microscope that uses one objective lens for focusing the illumination beam onto an object and the same objective for collecting the observation beam reflected from the object. This system employs a beam deflection unit for directing the illumination beam from the objective lens onto an object and for passing the observation beam reflected from the object to the same objective lens. The patent points out that the scanning may be obtained by either moving the beam deflection unit such that the illumination and observation beams scan the object, or by moving the object itself via a translation stage. However, no specific scanning mechanism is disclosed. The design of this system is such that it does not lend itself to miniaturization and fast scanning as required for *in vivo* imaging applications. Moreover, it provides inadequate working distance for *in vivo* imaging of live specimens since the object must be placed between the objective and the deflection unit.

One drawback to translating the object to be scanned is that in many applications it is difficult, if not entirely impossible, to maneuver the object such that high speed and precision scanning is attained. This problem can be particularly acute in imaging objects in scattering media, such as *in vivo* imaging of live tissue in biological and medical applications. Moving the two objective lenses through separate mechanisms as described in US Patent 5,973,828, on the other hand, requires that the translations of the illumination and observation

lenses be coordinated and synchronized such that the main lobes of the illumination and observation point-spread functions intersect optimally at all target points on the path to be scanned. Such coordination can be quite cumbersome to implement, rendering fast and high precision scanning difficult to achieve. Although the possibility of scanning the illumination and observation beams is proposed in US Patent 6,064,518, the particular design of the confocal theta microscope disclosed in this patent does not lend itself to fast and maneuverable scanning using this scheme.

Furthermore, as described in the above prior art, confocal theta microscopes use various mechanical pinholes to provide a point light source and a point detector. The disadvantage with using mechanical pinholes is the lack of flexibility and ruggedness. The optical systems incorporating mechanical pinholes are also difficult to align and miniaturize. In addition, slight misalignment of a mechanical pinhole or any other optical element can result in asymmetric intensity distribution of the light emerging from the pinhole, causing aberrations.

In recent years optical fibers have been used in confocal systems to transmit light more flexibly. A single-mode fiber is typically used so that an end of the fiber is also conveniently utilized as a pinhole for both light emission and detection. This arrangement is not susceptible to the alignment problems the mechanical pinholes in the prior art systems tend to suffer. Moreover, the use of optical fibers enables the microscopes to be more flexible and compact in structure, along with greater maneuverability in scanning. US Patents 5,120,953, 5,161,053, 5,742,419 and 5,907,425, for instance, disclose conventional reciprocal confocal scanning microscopes using a single optical fiber to transmit light. The end of the fiber provides a point illumination source and a point detector. The scanning in these systems is achieved by maneuvering the fiber end. Confocal theta microscopy is not employed in these systems, however.

Hence, what is needed in the art is a confocal scanning microscope that attains enhanced axial resolution, a long working distance and a large field of view, fast and high precision scanning, without involving complicated coordination of scanning actions. The desired confocal scanning microscope should also achieve high sensitivity and large dynamic range when imaging in a scattering medium, so as to produce high image contrast. Additionally, the desired confocal scanning microscope should have an integrated and scalable structure, rendering it a modular and versatile device.

#### OBJECTS AND ADVANTAGES

Accordingly it is a principal object of the present invention to provide an angled-dual-axis confocal scanning microscope for imaging in tissue or a scattering medium that:

- a) uses low NA and therefore inexpensive objective lenses;
- b) attains improved axial resolution;
- c) provides a larger field of view;
- d) affords a longer working distance;
- e) achieves higher sensitivity and larger dynamic range of detection;
- f) is fiber-coupled;
- g) has higher power efficiency;
- h) performs vertical cross-section scanning; and
- i) has small, compact, integrated, and simple construction.

It is a further object of the present invention to provide an assembly of fiber-based angled-dual-axis confocal scanning systems that advantageously combine the angled-dual-axis confocal scanning microscope of the present invention and fiber-optic components.

These and other objects and advantages will become apparent from the following description and accompanying drawings.



## SUMMARY OF THE INVENTION

This invention provides an angled-dual-axis confocal scanning microscope, comprising an angled-dual-axis confocal scanning head and a vertical scanning unit. The angled-dual-axis confocal scanning head further comprises a first end of a first single-mode optical fiber serving as a point light source, an angled-dual-axis focusing means, a scanning means, and a first end of a second single-mode optical fiber serving as a point light detector.

10

From the first end of the first optical fiber an illumination beam emerges. The angled-dual-axis focusing means serves to focus the illumination beam to a diffraction-limited illumination focal volume along an illumination axis within an object. The angled-dual-axis focusing means further receives an observation beam emanated from an observation focal volume along an observation axis within the object, and focuses the observation beam to the first end of the second optical fiber. The angled-dual-axis focusing means is so designed that the illumination axis and the observation axis intersect at an angle  $\theta$  within the object, such that the illumination and observation focal volumes intersect optimally at a confocal overlapping volume. The scanning means, in the form of a single scanning element disposed between the angled-dual-axis focusing means and the object, is positioned such that it receives the illumination beam from the angled-dual-axis focusing means and directs the illumination beam to the object; and that it collects the observation beam emanated from the object and passes the observation beam to the angled-dual-axis focusing means. The scanning means is further capable of pivoting the illumination and observation beams jointly in such a way that the illumination and observation axes remain intersecting optimally at a fixed angle  $\theta$  and that the confocal overlapping volume moves along an arc-line within the object, thereby producing an arc-line scan. The vertical scanning unit comprises a vertical translation means and a compensation means. The vertical translation means is mechanically coupled to the angled-dual-axis confocal scanning head, such that it

35

causes the angled-dual-axis confocal scanning head to move towards or away from the object, whereby a succession of arc-line scans that progressively deepen into the object is produced, providing a two-dimensional vertical cross-section scan of the object. The compensation means keeps the optical path lengths of the illumination and observation beams substantially unchanged, thereby ensuring the optimal intersection of the illumination and observation focal volumes in the course of vertical scanning. Altogether, the angled-dual-axis confocal scanning microscope of the present invention is designed such that it is capable of performing vertical cross-section scanning in a line-by-line fashion with enhanced axial (i.e., vertical) resolution and greater speed, while maintaining a workable working distance and a large field of view. Additionally, the object may be moved incrementally in a direction perpendicular to the vertical cross-section scan plane as each vertical cross-section scan is completed, resulting in a plurality of vertical cross-section images that can be assembled into a three-dimensional image of a region within the object.

It is to be understood that the term "emanating" as used in this specification is to be construed in a broad sense as covering any light transmitted back from the object, including reflected light, scattered light, and fluorescent light. It should be also understood that when describing the intersection of the illumination and observation beams in this specification, the term "optimal" means that the illumination and observation focal volumes (i.e., the main lobes of the illumination beam's point-spread function and the observation beam's point-spread function) intersect in such a way that their respective centers substantially coincide and the resulting overlapping volume has comparable transverse and axial extents. This optimal overlapping volume is termed "confocal overlapping volume" in this specification.

In an angled-dual-axis confocal scanning head of the present invention, the angled-dual-axis focusing means generally

comprises an assembly of beam focusing, collimating, and deflecting elements. Such elements can be selected from the group of refractive lenses, diffractive lenses, GRIN lenses, focusing gratings, micro-lenses, holographic optical elements, binary lenses, curved mirrors, flat mirrors, prisms and the like. A crucial feature of the angled-dual-axis focusing means is that it provides an illumination axis and an observation axis that intersect optimally at an angle  $\theta$ . The scanning means typically comprises an element selected from the group consisting of mirrors, reflectors, acousto-optic deflectors, electro-optic deflectors, mechanical scanning mechanisms, and Micro-Electro-Mechanical-Systems (MEMS) scanning micro-mirrors. A key feature is that the scanning means is in the form of a single element, as opposed to two or more separate scanning elements in many prior art confocal scanning systems. A preferred choice for the scanning means is a flat pivoting mirror, particularly a silicon micro-machined scanning mirror for its compact and light-weight construction. Moreover, the optical fibers can be single-mode fibers, multi-mode fibers, birefringent fibers, polarization maintaining fibers and the like. Single-mode fibers are preferable in the present invention, for the ends of single-mode fibers provide a nearly point-like light source and detector.

A unique feature of the angled-dual-axis confocal scanning head of the present invention is that the scanning means is placed between the angled-dual-axis focusing means and the object to be examined. This enables the best on-axis illumination and observation point-spread functions to be utilized throughout the entire angular range of an arc-line scan, thereby providing greater resolution over a larger transverse field of view, while maintaining diffraction-limited performance. Such an arrangement is made possible by taking advantage of the longer working distance rendered by using relatively lower NA focusing elements or lenses in the angled-dual-axis focusing means.

Another important advantage of the angled-dual-axis arrangement of the present invention is that since the observation beam is

positioned at an angle relative to the illumination beam, scattered light along the illumination beam does not easily get passed into the observation beam, except where the beams overlap. This substantially reduces scattered photon noise in the observation beam, thus enhancing the sensitivity and dynamic range of detection. This is in contrast to the direct coupling of scattered photon noise between the illumination and observation beams in a transmission or reciprocal confocal microscope, due to the collinear arrangement between the beams.

Moreover, by using low NA focusing elements (or lenses) in an angled-dual-axis confocal scanning system of the present invention, the illumination and observation beams do not become overlapping until very close to the focus. Such an arrangement further prevents scattered light in the illumination beam from directly "jumping" to the observation beam, hence further filtering out scattered photon noise in the observation beam. Altogether, the angled-dual-axis confocal system of the present invention has much lower noise and is capable of providing much higher contrast when imaging in a scattering medium than the prior art confocal systems employing high NA lenses, rendering it highly suitable for imaging within biological specimens.

A further advantage of the present invention is that the entire angled-dual-axis confocal scanning head can be mounted on a silicon substrate etched with precision V-grooves where various optical elements are hosted. Such an integrated device offers a high degree of integrity, maneuverability, scalability, and versatility, while maintaining a workable working distance and a large field of view. In particular, a micro-optic version of an integrated, angled-dual-axis confocal scanning head of the present invention can be very useful in biological and medical imaging applications, e.g., endoscopes and hand-held optical biopsy instruments.

The present invention further provides a first angled-dual-axis confocal scanning system, comprising an angled-dual-axis confocal scanning microscope of the present invention, a light source, and an optical detector. The light source is optically

coupled to the second end of the first optical fiber of the angled-dual-axis confocal scanning microscope, providing an illumination beam; and the optical detector is optically coupled to a second end of the second optical fiber of the angled-dual-axis confocal scanning microscope, receiving an observation beam collected from an object. The light source can be a continuous wave (CW) or a pulsed source such as a fiber laser, a semiconductor optical amplifier, an optical fiber amplifier, a semiconductor laser, a diode pumped solid state laser, or other suitable fiber-coupled light source known in the art. The optical detector can be a PIN diode, an avalanche photo diode (APD), or a photomultiplier tube. Such an angled-dual-axis confocal scanning system provides a simple and versatile imaging tool with high resolution and fast scanning capability.

It is known in the art that many biological tissues, such as tendons, muscle, nerve, bone, cartilage and teeth, exhibit birefringence due to their linear or fibrous structure. Birefringence causes the polarization state of light to be altered (e.g., rotated) in a prescribed manner upon reflection. Skin is another birefringent medium. Collagen contained in skin is a weakly birefringent material. At temperatures between 56-65 °C, collagen denatures and loses its birefringence. Thus, by detecting induced changes in the polarization state of light reflected from a skin sample, an image representing the regions of skin where thermal injury occurs can be identified. The angled-dual-axis confocal scanning system described above can be modified to image such a birefringent-scattering (or other polarization-altering) medium. A polarized light source is optically coupled to a second end of the first optical fiber of the angled-dual-axis confocal scanning microscope, providing a polarized illumination beam. The birefringent (or other polarization-altering) "scatterers" emanate an observation beam whose polarization is altered (e.g., rotated) relative to the polarization of the illumination beam. Such a rotated polarization can be represented in two orthogonal polarization components. A polarizing beamsplitter is then optically coupled

to a second end of the second optical fiber of the angled-dual-axis confocal scanning microscope, serving to route the two orthogonal polarization components of the observation beam to two separate optical detectors. An image representing the  
5 birefringent (or other polarization-altering) "scatterers" can be accordingly constructed.

The present invention also provides an angled-dual-axis confocal scanning module, comprising an angled-dual-axis  
10 confocal scanning microscope of the present invention optically coupled to a non-reciprocal three-port optical circulator. The third and first ports of the optical circulator are optically coupled to the second ends of the first and second optical fibers of the angled-dual-axis confocal scanning microscope,  
15 respectively; and the second port of the optical circulator serves as a bi-directional input/output port. The configuration of the angled-dual-axis confocal scanning module is such that an illumination beam transmitted to the second port is in turn passed into the third port of the optical  
20 circulator and then coupled to the second end of the first optical fiber of the angled-dual-axis confocal scanning microscope in nearly its entirety; and an observation beam collected by the angled-dual-axis confocal scanning microscope is delivered to the first port and then routed to the second  
25 port of the optical circulator, to be further utilized or detected in nearly its entirety. As such, the angled-dual-axis confocal scanning module of the present invention provides a modular angled-dual-axis confocal scanning device with a single input/output port, and can be readily adapted in a variety of  
30 applications, as the following embodiments demonstrate.

For example, by coupling the angled-dual-axis confocal scanning module of the present invention to a first output aperture of a self-detecting laser source having two output apertures, an  
35 illumination beam is transmitted from the first output aperture of the laser to the angled-dual-axis confocal scanning module, and an observation beam collected by the module is in turn back coupled to the laser via the same output aperture. The

feedback of the observation beam emanated from an object alters the light intensity as well as the modes supported by the laser cavity, and the resulting changes or perturbations can be detected by coupling an optical detector to a second output aperture of the laser. The presence of the non-reciprocal optical circulator in the angled-dual-axis confocal scanning module allows nearly 100% of the observation beam to be back coupled to the laser, hence maximizing the signal-to-noise ratio in detection. The use of a self-detecting laser as an integrated light source and detector further simplifies the structure of this angled-dual-axis confocal scanning system. Moreover, a frequency shifter (or a phase modulator) can be optically coupled to this angled-dual-axis confocal scanning system, arranged such that the frequency of the observation beam is shifted. The feedback of the frequency-shifted (or phase-modulated) observation beam to the laser results in the laser's output beam being modulated at a beat frequency, thereby allowing for more sensitive heterodyne detection. The system thus described constitutes the second angled-dual-axis confocal scanning system of the present invention.

If the self-detection laser source is equipped with only one output aperture, the angled-dual-axis confocal scanning module of the present invention can be optically coupled to the laser via a beam-splitting means, such as a 90/10 fiber-optic coupler or other low-coupling tap coupler. The beam-splitting means serves to divert a portion of the laser's output beam, which carries the perturbations due to the back coupling of the observation beam, to a detection path to which an optical detector may be coupled. Such a system constitutes the third angled-dual-axis confocal scanning system of the present invention.

The self-detecting characteristics of lasers have been advantageously exploited in the art to provide an integrated light source and detector, which also demonstrates the inherent high sensitivity of this method of optical detection. A great deal of effort has also been devoted to eliminate such

sensitive feedback effects (e.g., optical isolators with non-reciprocal optical elements such as Faraday rotators are designed to eliminate or block the back-coupling of light). In the present invention, the self-detecting laser can be a fiber  
5 laser, a semiconductor laser, or a diode pumped solid state laser. A fiber-based laser system, such as the fiber laser disclosed by the inventors of this application in US Patent 5,887,009, may be used to take advantage of the inherent flexibility of laser cavity parameters. A semiconductor laser  
10 may also be desirable as a low cost device.

The angled-dual-axis confocal scanning module of the present invention can also be optically coupled to a light source via a second non-reciprocal, three-port optical circulator. In this  
15 embodiment, an output aperture of the light source is optically coupled to a first port of the second optical circulator and a second port of the second optical circulator is in turn optically coupled to the input/output port of the angled-dual-axis confocal scanning module, such that an illumination beam  
20 is passed from the light source into the angled-dual-axis confocal scanning module in nearly its entirety. The optical coupling between the second optical circulator and the angled-dual-axis confocal scanning module is preferably provided by a single optical fiber, though other optical coupling means can  
25 also be implemented. An observation beam collected by the angled-dual-axis confocal scanning module is then routed to a third port of the second optical circulator, which further leads to a detection path, preferably in the form of a detection optical fiber. An optical detector may be optically  
30 coupled to the detection optical fiber. In this angled-dual-axis confocal scanning system, the light source may be any suitable laser or non-laser source, which operates in either continuous or pulsed mode. In fact, a skilled artisan may implement any light source suitable for a given application.  
35 Moreover, the non-reciprocal nature of the second optical circulator allows nearly 100% of the observation beam to be used for detection, hence maximizing the signal-to-noise ratio.



The system thus described constitutes the fourth angled-dual-axis confocal scanning system of the present invention.

5 The fourth angled-dual-axis confocal scanning system described above can be further modified into an interferometer configuration, such that the observation beam is combined with a portion of the output beam from the light source to create coherent interference. This can be achieved by inserting a beam-splitting means, such as a fiber-optic coupler or a  
10 beamsplitter, between the light source and the second optical circulator. In such an arrangement, the beamsplitting means diverts a portion of the output beam emitted from the light source to the first port of the second optical circulator, which is in turn routed to the angled-dual-axis confocal  
15 scanning module, providing an illumination beam. The remainder of the output beam from the light source is diverted to a reference path, preferably in the form of a reference optical fiber, providing a reference beam. The third port of the second optical circulator then routes an observation beam  
20 collected by the angled-dual-axis confocal scanning module to a detection path, preferably in the form of a detection optical fiber. The reference and detection optical fibers may be coupled by a 50/50 fiber-optic coupler to mix the observation and reference beams, and produce two outputs with a  $\pi$  phase  
25 difference for use in a balanced detection scheme. In this way, an interferometer is created and the length of the reference optical fiber can be adjusted to achieve coherent interference between the observation and reference beams.

30 The system described above, hence the fifth angled-dual-axis confocal scanning system of the present invention, may further include a frequency shifter (or a phase modulator), arranged such that the frequency of either the reference or the observation beam is shifted, so as to generate coherent  
35 heterodyne interference between the observation and reference beams. Heterodyne balanced detection technique, well-known in the art of optical coherence tomography (OCT), can be accordingly utilized. An adjustable optical delay device can

also be implemented in such a way to maintain coherent interference between the reference and observation beams. If the light source has a short coherence length, then the delay can be adjusted such that only single-scattered light in the observation beam is coherent with the reference beam at the 50/50 fiber-optic coupler and multiple-scattered light, which traverses over a larger optical path length in the observation beam, does not contribute to the coherent interference, therefore providing further filtering of multiple-scattered light. To enhance the signal-to-noise ratio in detection, an optical amplifier, such as a two-port fiber amplifier or semiconductor optical amplifier (SOA), can be coupled to the detection optical fiber, such that the observation beam is amplified. An amplified observation beam also allows faster scanning rates and consequently higher pixel rates without appreciable loss in signal-to-noise ratio, because a shorter integration time per pixel of an image is required in data collection.

The light source in the fifth angled-dual-axis confocal scanning system of the present invention can be an optical fiber amplifier, a semiconductor optical amplifier, a fiber laser, a semiconductor laser, a diode-pumped solid state laser, or a continuous wave or pulsed broadband OCT source having a short coherence length, as is well known in the art. If polarized light is provided by the light source, the beam-splitting means should be a polarizing beamsplitter, such as a polarizing beamsplitter evanescent wave optical fiber coupler, and the various optical fibers in the system should be polarization maintaining (PM) fibers. In this case, the observation and reference beams can be brought into the same polarization by rotation of either the reference or detection optical fiber. Alternatively, a polarization rotation means, such as a Faraday rotator, can be coupled to either the reference or detection optical fiber, such that the reference and observation beams have substantially the same polarization when combined. Furthermore, the 50/50 fiber-optic coupler can

be a polarization maintaining fiber coupler to optimally mix the polarized observation and reference beams.

A distinct advantage of the angled-dual-axis confocal scanning microscope of the present invention is that the scanning is achieved by pivoting both the illumination and observation beams, as opposed to moving either the object or the microscope's objective lenses in the prior art confocal theta scanning microscopes, which adversely limits the speed and maneuverability of scanning. Moreover, a single-element scanning means, such as a micro-machined scanning mirror, is used to pivot the illumination and observation beams jointly, in contrast to the prior art systems where the two beams are scanned individually by way of moving the microscope's objectives lenses separately, which requires precise synchronization and coordination in maneuvering the lenses. In addition, by disposing the scanning means between the angled-dual-axis focusing means and the object, fast and high-precision scanning at high resolution is obtained over a large field of view. Such an arrangement takes advantage of the long working distance rendered by using low NA focusing elements (or lenses). Another important advantage gained by using low NA focusing elements is that the illumination and observation beams do not become overlapping until sufficiently close to the focus. This prevents scattered light in one beam from directly "jumping" to another beam, hence eliminating scattered photon noise in the observation beam. Furthermore, low NA lenses can be easily designed for aberration correction, thus allowing diffraction-limited performance at relatively low cost. In the present invention, diffraction-limited focusing is only required "on-axis", hence further simplifying the lens requirements. The angled-dual-axis confocal scanning microscope of the present invention further advantageously exploits the flexibility, scalability and integrity afforded by optical fibers and silicon micro-machining techniques, rendering it a highly versatile and modular device. Accordingly, the angled-dual-axis confocal scanning microscope of the present invention is particularly suited for

applications in which high resolution and fast scanning are required, such as *in vivo* imaging of live tissue for performing optical biopsies in medical applications.

5 By integrating the angled-dual-axis confocal scanning microscope of the present invention with fiber-optic components and a fiber-coupled laser, the angled-dual-axis confocal scanning systems of the present invention provide a diverse assembly of fiber-based, high resolution and fast scanning  
10 systems that can be adapted in a variety of applications, such as in biological and medical imaging, and industrial applications.

The novel features of this invention, as well as the invention  
15 itself, will be best understood from the following drawings and detailed description.

#### BRIEF DESCRIPTION OF THE FIGURES

FIGS. **1A-1D** shows several exemplary embodiments of an angled-dual-axis confocal scanning head according to the  
20 present invention;

FIGS. **2A-2B** depict two exemplary embodiments of an angled-dual-axis confocal scanning microscope according to the present invention;

25 FIGS. **3A-3B** show two exemplary embodiments of a first angled-dual-axis confocal scanning system according to the present invention;

FIG. **4** depicts an exemplary embodiment of an angled-dual-axis confocal scanning module according to the present  
30 invention;

FIGS. **5A-5B** show simplified schematic diagrams of second and third angled-dual-axis confocal scanning systems according to the present invention;

35 FIGS. **6A-6B** depict simplified schematic diagrams of fourth and fifth angled-dual-axis confocal scanning systems according to the present invention; and

FIG. **7** illustrates a configuration of two intersecting beams according to an embodiment of the present invention; and

FIGS. **8A-8C** show graphs of normalized confocal-signal as a function of position in the x, y, z directions according to exemplary embodiments of the present invention.

5

## DETAILED DESCRIPTION

Although the following detailed description contains many specific details for the purposes of illustration, anyone of ordinary skill in the art will appreciate that many variations and alterations to the following details are within the scope of the invention. Accordingly, the exemplary embodiment of the invention described below is set forth without any loss of generality to, and without imposing limitations upon, the claimed invention.

15

FIGS. **1A-1D** depict several exemplary embodiments of an angled-dual-axis confocal scanning head according to the present invention. Depicted in FIG. **1A** is a first exemplary embodiment of an angled-dual-axis confocal scanning head of the present invention. Confocal scanning head **100**, by way of example, comprises a first end **101** of a first optical fiber **103** serving as a point light source; a first end **102** of a second optical fiber **104** serving as a point light detector; an angled-dual-axis focusing means in the form of a lens assembly consisting of first collimating lens **105**, second collimating lens **106**, illumination lens **107**, observation lens **108**, and two beam-aligning elements in the form of first 45-degree mirror **109** and second 45-degree mirror **110**; a scanning means in the form of a single scanning mirror **111**, which can be pivoted about axis **122**, and a silicon substrate **112**. First collimating lens **105**, illumination lens **107**, and first mirror **109** are mounted on first V-groove **113** etched on substrate **112**. Similarly, second collimating lens **106**, observation lens **108**, and second mirror **110** are mounted on second V-groove **114** etched on substrate **112**. First optical fiber **103** and second optical fiber **104** are affixed to cylindrical ferrules **115** and **116** respectively, which are in turn mounted on V-grooves **113** and **114** respectively, such

that fiber ends **101** and **102** are held in their respective positions.

In operation, an illumination beam **117** emerges from first end  
5 **101** of first optical fiber **103** and is directed to first collimating lens **105**. The collimated beam is then passed onto and focused by illumination lens **107**. The focused beam is further deflected by first mirror **109** to scanning mirror **111**, which in turn directs the beam to a diffraction-limited  
10 illumination focal volume (see FIG. **1B**) within an object **120**. An observation beam **118** emanated from a diffraction-limited, confocal overlapping volume **121** is first collected by scanning mirror **111**, then directed to second mirror **110**, which in turn deflects the beam to observation lens **108**. Observation beam  
15 **118** is then collimated by observation lens **108** and then focused by second collimating lens **106** to first end **102** of second optical fiber **104**. Scanning mirror **111** is positioned such that illumination beam **117** and observation beam **118** intersect optimally at an angle ( $\theta$ ) within object **120**.

20

FIG. **1B** provides a more detailed illustration of how illumination beam **117** and observation beam **118** are arranged to intersect within object **120** in FIG. **1A**. Illumination beam **117**, directed by scanning mirror **111**, is focused to an illumination  
25 focal volume **99** oriented along an illumination axis **97** within object **120**. Observation beam **118** emanates from an observation focal volume **98** oriented along an observation axis **96** within object **120**. Observation beam **118** is received by scanning mirror **111**. Illumination axis **97** and observation axis **96** are  
30 directed to intersect at an angle  $\theta$ , such that illumination focal volume **99** and observation focal volume **98** intersect optimally at confocal overlapping volume **121**. A three-dimensional x-y-z coordinate system is provided to describe the spatial extents of confocal overlapping volume **121**, where the  
35 origin of the coordinate system is set at the center of confocal overlapping volume **121**. The z-axis defines the axial (or vertical) direction, whereas x-axis and y-axis (pointing

out of the page) represent two orthogonal transverse directions.

It is to be understood that the term "emanating" as used in this specification is to be construed in a broad sense as covering any light transmitted back from the object, including reflected light, scattered light, or fluorescent light. A skilled artisan will know how to selectively make use of a particular type of light collected from the object and filter out spurious background light for a given application.

In the present invention, various optical elements are aberration-corrected, and single-mode optical fibers are used to provide a point light source and detector. Accordingly, illumination focal volume **99** and observation focal volume **98** described above are diffraction-limited, defined by the main lobes of the illumination beam's point-spread function and observation beam's point-spread function. Confocal overlapping volume **121** is likewise diffraction-limited, determined by an optimal overlapping of the main lobes of the illumination beam's point-spread function and the observation beam's point-spread function, as illustrated in FIG. **1B**.

The present invention provides a model for calculating the point-spread functions of two optimally intersecting focused beams, such as illumination beam **117** and observation beam **118** exemplified in FIG. **1B**, thereby providing an estimate of the three-dimensional extents of the resulting confocal overlapping volume, such as confocal overlapping volume **121**. The model calculation is presented as follows.

FIG. **7** illustrates a configuration in which two focused, diffraction-limited beams **beam-1**, **beam-2**, intersect at an angle  $2\alpha$ , where **beam-1** and **beam-2** can be illumination and observation beams respectively in an angled-dual-axis arrangement described above. A central x-y-z coordinate system is provided, such that z-axis defines the axial (or vertical) direction, and x-axis and y-axis (pointing out of the page) represent two

orthogonal transverse directions. There are two additional coordinate systems, where the  $x_1-y_1-z_1$  coordinate system is associated with **beam-1** and the  $x_2-y_2-z_2$  coordinate system is associated with **beam-2**. All three coordinate systems share the same origin **O**, which is located at the center of the two-beam overlapping region. The transformations between the coordinate systems associated with the beams and the central coordinate system are given by:

$$\begin{aligned}
 x_1 &= x \cos \alpha + z \sin \alpha \\
 y_1 &= y \\
 z_1 &= -x \sin \alpha + z \cos \alpha \\
 x_2 &= x \cos \alpha - z \sin \alpha \\
 y_2 &= y \\
 z_2 &= x \sin \alpha + z \cos \alpha
 \end{aligned}$$

Using paraxial theory, and assuming that the electric-field associated with each beam is polarized in the  $y$  direction (i.e., perpendicular to the page). (It can be shown that for reflection from a perfect mirror or from a small particle, the same results would be obtained for the electric-field to be polarized along the  $x-z$  plane). Further introducing normalized notations:

$$\begin{aligned}
 u_1 &= knz_1 \sin^2 \theta_0, v_1 = knr_1 \sin \theta_0 = kn \sin \theta_0 \sqrt{x_1^2 + y_1^2} \\
 u_2 &= knz_2 / \sin^2 \theta_0, v_2 = knr_2 / \sin \theta_0 = kn \sin \theta_0 \sqrt{x_2^2 + y_2^2}
 \end{aligned}$$

where  $\theta_0$  is the maximum ray angle relative to the axis of each of the objective lenses which serve to focus **beam-1** and **beam-2**,  $k = 2\pi/\lambda$ , and  $n$  is the index of refraction of the medium in which **beam-1** and **beam-2** intersect. Note that NA of each objective lens in air is given by  $\sin \theta_0$  (For the sake of simplicity, and without losing any generality, the two objective lenses are assumed to have the same NA.)

It can be shown (e.g., see "Principles of Optics" of Max Born and Emil Wolf, Pergamon Press, 1980, pp.437) that the amplitude at point  $(x, y, z)$  associated with **beam-1** in the two-beam overlapping region is proportional to



$$U_1 = \int_0^1 J_0(\rho v_1) e^{-j u_1 \rho^2 / 2} \rho d\rho$$

Similarly, the amplitude associated with **beam-2** at the same  
5 point  $(x, y, z)$  is proportional to

$$U_2 = \int_0^1 J_0(\rho v_2) e^{-j u_2 \rho^2 / 2} \rho d\rho$$

It follows that the "confocal-signal", resulting from the  
10 overlap of **beam-1** and **beam-2**, is proportional to

$$V = (U_1 U_2)^2$$

FIG. **8A-8C** each display three graphs of normalized "confocal-  
15 signal"  $V/V_{\max}$  plotted as a function of  $x$ ,  $y$ , and  $z$   
respectively, where the origin of each graph corresponds with  
the origin **O** of the  $x$ - $y$ - $z$  coordinate system. These graphs are  
provided by the model calculation described above, for several  
exemplary cases having different values of the intersecting  
20 angle  $2\alpha$  and NA of the objective lenses. It is assumed that  $\lambda$   
=  $1.3 \mu\text{m}$  and  $n = 1.35$  in all the cases. A distinct feature  
prevalent in all the graphs shown in FIG. **8A-8C** is that  $V/V_{\max}$   
exhibits a Gaussian-like shape in each spatial dimension,  
diminishing rapidly and monotonically (i.e., there are no  
25 additional side-lobes) with increasing distance from the center  
of the two-beam overlapping region. Such characteristics  
define a sharp resolution in both the axial as well as  
transverse directions. In fact, the full width of each  
Gaussian-like curve at half of its maximum amplitude,  $D$ ,  
30 provides a measure of the spatial extent of the confocal  
overlapping volume, hence the spatial resolution, in the given  
direction for the particular case in consideration. For  
comparison purpose, the  $D$  values obtained for the exemplary  
cases as well as a few others are listed in **TABLE I** shown  
35 below.

TABLE I

NA	$\alpha$	$D$ ( $\mu\text{m}$ )	$D$ ( $\mu\text{m}$ )	$D$ ( $\mu\text{m}$ )
		x-direction	y-direction	z-direction
0.3	$30^\circ$	1.36	1.18	2.34
0.25	$30^\circ$	1.63	1.42	2.81
0.2	$30^\circ$	2.04	1.77	3.52
0.3	$36^\circ$	1.46	1.18	1.99
0.2	$36^\circ$	2.19	1.77	3.00
0.3	$45^\circ$	1.66	1.18	1.66
0.2	$45^\circ$	2.50	1.77	2.50

Now referring back to FIG. **1A**, by rotating about axis **122** at a variable angle  $\phi$ , scanning mirror **111** is further capable of pivoting illumination beam **117** and observation beam **118** jointly  
 5 in such a way that illumination beam **117** and observation beam **118** remain intersecting optimally at angle  $\theta$  ( $=2\alpha$ ) and confocal overlapping volume **121** at the intersection of the two beams moves along an arc-line within object **120**, thereby producing an arc-line scan.

10

It should be noted that an important characteristic of the arc-line scan described above is that the relative spatial orientation between illumination beam **117** and observation beam **118** stays fixed in the course of the entire scan, once the two  
 15 beams are arranged to intersect in an optimal manner initially. This is in distinct contrast to the prior art confocal theta scanning systems, where the illumination and observation beams need to be separately adjusted at each scan point, in order to ensure an optimal intersection. Consequently, the scans  
 20 performed by angled-dual-axis confocal scanning head **100** of the present invention are inherently of higher precision and faster speed, and are also less laborious to carry out. Another notable feature of angled-dual-axis confocal scanning head **100** of the present invention is that the illumination and  
 25 observation beam paths can be exchanged, without affecting its performance.

FIG. **1C** shows a second exemplary embodiment of an angled-dual-axis confocal scanning head of the present invention. In angled-dual-axis confocal scanning head **150**, an illumination reflective focusing element **151** is implemented to replace first collimating lens **105**, illumination lens **107**, and first mirror **109** in FIG. **1A**, providing a dual function of focusing and deflecting illumination beam **117**. Likewise, an observation reflective focusing element **152** is used to replace second mirror **110**, observation lens **108**, and second collimating lens **106** in FIG. **1A**, providing a dual function of focusing and deflecting observation beam **118**. The remainder of angled-dual-axis confocal scanning head **150** shares the same components with angled-dual-axis confocal scanning head **100** in FIG. **1A**. By way of example, illumination and observation reflective focussing elements **151**, **152** are in the form of two diffractive lenses with reflective coatings. The proper design of such reflective diffraction lenses can be determined by commercially available computer modeling programs and is well known in the art of diffractive lens design. Illumination and observation reflective focusing elements **151**, **152** can alternatively be in the form of curved mirrors. In some cases of using curved mirrors such as ellipsoidal mirrors (each having two foci), it is desirable to place fiber ends **101**, **102** at the respective first focal points of the two ellipsoidal mirrors serving as illumination and observation focusing elements **151**, **152**, thereby focusing illumination beam **117** and observation beam **118** at the respective second focal points of focusing elements **151**, **152**. All in all, the overall operation of angled-dual-axis confocal scanning head **150** is similar to the working of angled-dual-axis confocal scanning head **100**, as described above.

FIG. **1D** depicts a simplified schematic illustration of a third exemplary embodiment of an angled-dual-axis confocal scanning head of the present invention. Angled-dual-axis confocal scanning head **170** comprises a first end **171** of a first optical fiber **173** serving as a point light source; a first end **172** of a second optical fiber **174** serving as a point light detector; an angled-dual-axis focusing means in the form of a lens assembly

consisting of first collimating lens **175**, second collimating lens **176**, and illumination-observation lens **177**; and a scanning means in the form of a single scanning mirror **178** having a pivoting axis **185**.

5

In operation, an illumination beam **179** emerges from first end **171** of first optical fiber **173** and is directed to first collimating lens **175**. The collimated beam is then passed onto and focused by illumination-observation lens **177**. The focused beam reflects off scanning mirror **178** at first impingement spot **183**, and is further directed to a diffraction-limited illumination focal volume (not shown in FIG. **1D**) within an object **182**. An observation beam **180** emanated from a diffraction-limited, confocal overlapping volume **181** is first received by scanning mirror **178** at second impingement spot **184**, further passed onto and collimated by illumination-observation lens **177**. Observation beam **180** is then focused by second collimating lens **176** to first end **172** of second optical fiber **174**. Scanning mirror **178** is positioned such that illumination beam **179** and observation beam **180** intersect optimally at an angle ( $\theta$ ) within confocal overlapping volume **181**, as illustrated in FIG. **1B**. By rotating about axis **185**, scanning mirror **178** is further capable of pivoting illumination beam **179** and observation beam **180** jointly in such a way that illumination beam **179** and observation beam **180** remain intersecting optimally at angle  $\theta$  and confocal overlapping volume **181** at the intersection of the two beams moves along an arc-line within object **120**, thereby producing an arc-line scan, as in the embodiment of FIG. **1A** or FIG. **1C**.

10  
15  
20  
25  
30

It should be noted that in an angled-dual-axis arrangement of the present invention, as the above exemplary embodiments depict, since the observation beam is positioned at an angle relative to the illumination beam, scattered light along the illumination beam does not easily get passed into the observation beam, except where the beams overlap. This substantially reduces scattered photon noise in the observation beam, thus enhancing the sensitivity and dynamic range of

35

detection. This is in contrast to the direct coupling of scattered photon noise between the illumination and observation beams in a transmission or reciprocal confocal microscope, due to the collinear arrangement between the beams. Moreover, by using low NA focusing elements (or lenses) in an angled-dual-axis confocal scanning system of the present invention, the illumination and observation beams do not become overlapping until very close to the focus. Such an arrangement prevents scattered light in the illumination beam from directly "jumping" to the observation beam, hence further filtering out scattered photon noise in the observation beam. Altogether, the angled-dual-axis confocal system of the present invention has much lower noise and is capable of providing much higher contrast when imaging in a scattering medium than the prior art confocal systems employing high NA lenses, rendering it highly suitable for imaging within biological specimens.

FIGS. **1A, 1C-1D** serve to illustrate only three of many embodiments of an angled-dual-axis confocal scanning head of the present invention. In general, the angled-dual-axis focusing means in an angled-dual-axis confocal scanning head of the present invention comprises an assembly of one or more elements for beam focusing, collimating, aligning, and deflecting, as exemplified in FIGS. **1A, 1C-1D**. Such elements can be in the form of refractive lenses, diffractive lenses, GRIN lenses, focusing gratings, micro-lenses, holographic optical elements, binary lenses, curved mirrors, flat mirrors, prisms and the like. A crucial feature of the angled-dual-axis focusing means is that it provides an illumination axis and an observation axis that intersect at an angle, as illustrated in FIG. **1B**. The scanning means in an angled-dual-axis confocal scanning head of the present invention generally comprises an element selected from the group consisting of mirrors, reflectors, acousto-optic deflectors, electro-optic deflectors, mechanical scanning mechanisms, and Micro-Electro-Mechanical-Systems (MEMS) scanning micro-mirrors. A key feature is that the scanning means is in the form of a single element, as opposed to two or more separately functioning scanning elements

in prior art confocal scanning systems. A preferred choice for the scanning means is a flat pivoting mirror, particularly a silicon micro-machined scanning mirror for its compact and light-weight construction. (Note: to achieve faster scanning, the scanning means can be in the form of two smaller coplanar pivoting mirrors, such as two silicon micro-machined scanning mirrors. Owing to their unique fabrication process, these mirrors can be operated in substantially synchronous motion and constructed to co-rotate about a common axis so as to scan illumination and observation beams in a way functionally equivalent to a larger single scanning mirror.) The fabrication processes of silicon scanning mirrors are described in US Patents 6,007,208, 6,057,952, 5,872,880, 6,044,705, 5,648,618, 5,969,465 and 5,629,790. The optical fibers in an angled-dual-axis confocal scanning head of the present invention can be single-mode fibers, multi-mode fibers, birefringent fibers, polarization maintaining fibers and the like. Single-mode fibers are preferable, however, for the ends of single-mode fibers provide a nearly point-like light source and detector.

A unique feature of the angled-dual-axis confocal scanning head of the present invention is that the scanning means is placed between the angled-dual-axis focusing means and the object to be examined. This enables the best on-axis illumination and observation point-spread functions to be utilized throughout the entire angular range of an arc-line scan, thereby providing greater resolution over a larger transverse field of view, while maintaining diffraction-limited performance. Such an arrangement is made possible by taking advantage of the longer working distance rendered by using relatively lower NA focusing elements or lenses in the angled-dual-axis focusing means. For example, the present invention uses molded aspherical lenses with NA in the range of 0.1 to 0.4 that are low cost and readily available in the art. Such lenses have excellent on-axis aberration correction, and are therefore diffraction-limited for on-axis focusing conditions. These lenses normally do not have diffraction-limited performance when focusing off-

axis, and thus cannot be used in confocal scanning systems where off-axis performance is important. Such is the case in prior art confocal scanning systems described in US Patents 5,973,828 and 6,064,518, where the field of view is limited by  
5 the off-axis performance of objective lenses.

Moreover, the specific arrangements among various optical elements and optical fibers in an angled-dual-axis confocal scanning head can be altered in many ways without deviating  
10 from the principle and the scope of the present invention. For instance, the use of collimating lenses and beam-aligning mirrors, such as those in FIG. **1A** to help facilitate the shaping and alignment of the illumination and observation beams, can be optional and vary with the nature of practical  
15 applications. Other auxiliary optical elements may also be implemented in an angled-dual-axis confocal scanning head of the present invention, to enhance the overall performance. All in all, a skilled artisan will know how to design an angled-dual-axis confocal scanning head in accordance with the  
20 principle of the present invention, to best suit a given application.

By integrating its constituent optical elements on a silicon substrate, as exemplified in FIGS. **1A**, **1C** by way of silicon  
25 fabrication techniques, the angled-dual-axis confocal scanning head of the present invention renders a high degree of integrity, maneuverability, scalability, and versatility. Such a design also provides greater flexibility and higher precision in the alignment of various optical elements. Although the  
30 particular way of making an angled-dual-axis confocal scanning head of the present invention an integrated device is dictated by the nature of a given application, a silicon substrate is generally preferred, for it is well known in the art that various V-grooves can be etched on silicon in a very precise  
35 manner, as demonstrated in US Patent 6,007,028. The precision of the V-grooves provides an accurate and secure optical alignment among various optical elements hosted by these V-grooves, enabling the angled-dual-axis confocal scanning head

thus constructed to be a reliable and modular device. Using the embodiment of FIG. 1A as a way of example, mirrors 109, 110 can be rotated about their respective axes and translated along V-grooves 113, 114, respectively, to facilitate the optimal intersection of illumination and observation beams 117, 118. 5 Illumination and observation lenses 107, 108 can also be translated along V-grooves 113, 114 respectively, to further facilitate the optimal overlapping of illumination and observation focal volumes 99, 98 as illustrated in FIG. 1B. 10 Such alignment procedures can be performed before affixing (e.g., by way of gluing) various optical elements to their respective V-grooves. The scalability and relatively low cost of silicon fabrication technology add further advantages to this approach. For example, a micro-optic version of such an 15 integrated angled-dual-axis confocal scanning head can be incorporated in miniature surgical devices, endoscopes, or other *in situ* devices, suitable for medical applications.

To provide a two-dimensional scan, an angled-dual-axis confocal 20 scanning head of the present invention can be mechanically coupled to a vertical scanning unit, comprising a vertical translation means and a compensation means. The vertical translation means causes the angled-dual-axis confocal scanning head to move toward or away from the object and hence the 25 illumination and observation beams to probe further into the interior of the object, thereby producing a vertical scan. A two-dimensional vertical cross-section scan of the object is then obtained by assembling a plurality of arc-line scans that progressively deepen into the object. The compensation means 30 keeps the optical paths lengths of the illumination and observation beams substantially unchanged, thereby ensuring the optimal intersection of the illumination and observation focal volumes in the course of vertical cross-section scans. The combination of the angled-dual-axis confocal scanning head and 35 the corresponding vertical scanning unit constitutes an angled-dual-axis confocal scanning microscope employing vertical cross-section scanning. FIG. 2A depicts an exemplary embodiment of an angled-dual-axis confocal scanning microscope



of the present invention. Angled-dual-axis confocal scanning microscope **200**, by way of example, comprises an angled-dual-axis confocal scanning head (ADACSH) **201** and a movable carriage **202**. For the purpose of illustration, angled-dual-axis confocal scanning head **201** is in a simplified schematic form of the embodiment shown in FIG. **1A** (or FIG. **1C**), although any other embodiments according to the present invention can be equivalently utilized. In the embodiment of FIG. **2A**, angled-dual-axis confocal scanning head **201** is attached to and further enclosed in movable carriage **202**, with optical fibers **103**, **104** extending to the outside of movable carriage **202**. A first transparent window **203** is mounted on movable carriage **202** for passage of illumination beam **117** and observation beam **118**. Movable carriage **202** can move up and down in a vertical direction as defined by arrow **204**, causing angled-dual-axis confocal scanning head **201** to move toward or away from object **120** in the process. By doing so, confocal overlapping volume **121** of illumination beam **117** and observation beam **118** further deepen into (or retract from) the interior of object **120**, whereby a succession of arc-line scans that progressively deepen into object **120** along a vertical cross-section plane **210** is produced, as illustrated by curves **205**. The motion of movable carriage **202** can be driven by a variety of means, for instance, by coupling it to a motor (not shown in FIG. **2A**) that is activated by a magnetic, hydraulic, piezoelectric, or other actuator. A skilled artisan can accordingly implement a movable stage suitable for a given application.

As illumination beam **117** and observation beam **118** deepen into the interior of object **120** in the course of vertical scanning, the change in their respective optical path lengths becomes increasingly large, which may cause their respective focal volumes to no longer intersect in an optimal manner, or even not to intersect at all at the point where the two beams physically meet. Furthermore, in interferometry applications such as optical coherence microscopy, the optical path lengths of illumination beam **117** and observation beam **118** must stay substantially fixed in order to generate coherent interference

of predominantly singly scattered light. To maintain the optical path lengths of illumination beam **117** and observation beam **118** during vertical scanning, the space between movable carriage **202** and object **120** can be filled with a substantially transparent fluid **206** having an index of refraction that is substantially the same as the index of refraction of object **120**, such that the optical path lengths of illumination beam **117** and observation beam **118** remain unchanged in the course of vertical scanning. The use of optical fibers further provides the necessary flexibility that enables the whole assembly of angled-dual-axis confocal scanning head **201** and movable carriage **202** to move up and down without incurring additional change in the optical path lengths of illumination beam **117** and observation beam **118**. In the embodiment of FIG. **2A**, movable carriage **202**, along with angled-dual-axis confocal scanning head **201**, is disposed within a container **207** filled with fluid **206**. An O-ring seal **211** is provided to seal fluid **206** inside container **207**, while still permitting movable carriage **202** to move up and down relative to container **207**. Container **207** is equipped with a second transparent window **208**, in optical alignment with first transparent window **208** for passage of illumination and observation beams **117**, **118**. Container **207** is further connected to a fluid injection system **209**, serving as a reservoir for replenishing additional fluid or receiving excess fluid as movable carriage **202** is moving towards or away from object **120**. For imaging of human tissue and other biological samples, fluid **206** can be water, which has an index of refraction closely matching that of tissue and biological samples.

30

It should be noted that certain aberrations of the illumination and observation beams may occur as a result of successive passages of the beams through first and second transparent windows **203**, **208**, fluid **206**, and object **120** in the above embodiment, which may require specific designs of the illumination and observation focusing elements that are corrected for these aberrations. Alternatively, auxiliary optical elements that are properly designed for correcting such

35

aberrations may be implemented in the angled-dual-axis focusing means. In most cases of a converging beam passing through a window or into another object at an inclined angle, the primary aberrations to be corrected for will be spherical aberration, astigmatism, and coma. The magnitude of these aberrations depend upon many factors, and typically increases with NA of the focusing elements, the index of refraction and the thickness of the window, and the angle of incidence. The design of such aberration-corrected focusing elements, or auxiliary optical elements for correcting aberrations, can be accomplished by a lens designer of ordinary skill and with the help of an optical design computer program such as Zemax™.

In applications where NA of the focusing elements are sufficiently low and the thicknesses of windows, fluid and object through which the illumination and observation beams successively traverse are not large, the aberrations would be small and may not need to be corrected. In such cases, the embodiment shown in FIG. **2A** can be utilized, which may incorporate additional remedies for further minimizing aberrations. Such remedies include, for example, using windows made of Teflon AF™ or other materials that are transparent and have an index of refraction closely matching that of water.

FIG. **2B** depicts a second embodiment of an angled-dual-axis confocal scanning microscope of the present invention, pertaining to applications where the aforementioned aberrations may not be negligible. In angled-dual-axis confocal scanning microscope **250**, a window assembly comprising two flat transparent windows **254**, **255** in an angled arrangement is implemented to replace single flat window **203** in FIG. **2A**. The remainder of angled-dual-axis confocal scanning microscope **250** shares the same components as angled-dual-axis confocal scanning microscope **200** shown in FIG. **2A**. The window assembly is designed such that illumination axis **97** along with illumination beam **117** and observation axis **96** along with observation beam **118** (see FIG. **1B**) are substantially perpendicular to flat windows **255**, **254**, respectively. As such,

the window assembly can greatly reduce coma and astigmatism that would otherwise be associated with using a single flat window (such as window **203** in FIG. **2A**). Although spherical aberrations still need to be corrected for in this case, the techniques for making such corrections are well known in the art of lens design. For instance, a skilled artisan can make use of the design of microscope objectives that are corrected for glass coverslips of a certain thickness to accomplish this task.

10

All in all, the angled-dual-axis confocal scanning microscope of the present invention is designed such that it provides a vertical cross-section scan of an object with enhanced axial resolution, faster speed, and larger transverse field of view.

15

Moreover, by moving the angled-dual-axis confocal scanning microscope, or translating the object, in a transverse direction perpendicular to vertical cross-section plane **210** illustrated in FIG. **2A** (or FIG. **2B**), a series of vertical cross-section scans can be taken in a layer-by-layer fashion, which can be assembled to provide a three-dimensional volume image of the object.

20

For tissue imaging applications, the wavelength of light generally ranges from about 0.8 microns to 1.6 microns, since biological tissue samples are particularly transparent in this range. Embodiments of the angled-dual-axis confocal scanning microscope of the present invention are capable of achieving a resolution of about 1-5 microns in the axial (e.g., the vertical direction shown in FIG. **2A**) as well as the transverse directions, by use of illumination and observation lenses with NA typically ranging from 0.1 to 0.4, and the intersecting angle  $\theta$  typically ranging from  $45^\circ$  to  $90^\circ$ . The vertical cross-section scan area is on the order of about 0.5-1 millimeter in both directions. In terms of scanning capabilities, the fast scan rate along an arc-line typically ranges from 1 to 10 KHz, and the maximum rotation angle (e.g.,  $\phi$  in FIG. **1A**) from a neutral position of the scanning mirror (e.g., scanning mirror **111** in FIG. **1A**) may range from one to several degrees.

30

35

Generally, the smaller and the lighter the scanning mirror, the faster the scanning rate. For instance, using a silicon micro-machined scanning mirror can provide scanning rates greater than 10 kHz. The vertical scanning can be performed at a  
5 slower rate of 10-60 Hz, which defines the frame rate of vertical cross-section scanning and is in the range of video-rate scanning.

The specific numbers provided above are designed for tissue  
10 imaging, to illustrate the utility and the performance of the present invention as a way of example. A skilled artisan can utilize the model calculation described above to design an angled-dual axis confocal scanning microscope in accordance with the present invention, for a given application.

15

FIG. **3A** depicts an exemplary embodiment of a first angled-dual-axis confocal scanning system of the present invention. Angled-dual-axis confocal scanning system **300** comprises an angled-dual-axis confocal scanning microscope (ADACSM) **301**, a  
20 light source **302**, and an optical detector **303**. By way of example, angled-dual-axis confocal scanning microscope **301** is in a simplified schematic form of one of the embodiments shown in FIGS. **2S-2B**. Any other embodiment in accordance with the present invention can be alternatively implemented. Light  
25 source **302** is optically coupled to a second end **305** of first optical fiber **103**, to provide an illumination beam to angled-dual-axis confocal scanning microscope **301**. Optical detector **303** is optically coupled to a second end **304** of second optical fiber **104**, to receive an observation beam collected by angled-  
30 dual-axis confocal scanning microscope **301** from confocal overlapping volume **121** within object **120**. Light source **302** can be a fiber laser, a semiconductor optical amplifier, an optical fiber amplifier, a semiconductor laser, a diode-pumped solid state laser, or any other fiber-coupled light source known in  
35 the art. The wavelength of light provided by light source **302** is typically in the range of 0.8-1.6 microns, with an average power of about 20 to 200 milliwatts. Light source **302** may operate in a continuous wave (CW) or pulsed mode. Optical

detector **303** can be a PIN diode, or an avalanche photo diode (APD), for instance. In some cases where the observation beam is weak, a photomultiplier tube detector may be used. A skilled artisan will know how to select a proper optical  
5 detector for a given application, as described in "Building Electro-Optical Systems, Making it all work" by Philip C.D. Hobbs, John Wiley & Sons, 2000. The resulting signals from optical detector **303** can subsequently be electronically processed and assembled into corresponding image of vertical  
10 cross-section scans of object **120** by methods well known in the art. As such, angled-dual-axis confocal scanning system **300** provides a versatile and high-resolution imaging device, and can be readily employed in a variety of applications. Those skilled in the art can implement this angled-dual-axis confocal  
15 scanning system of the present invention in a way suitable for a given application.

The embodiment described above can also be used to provide specific information pertaining to the polarization state of  
20 light emanated from a polarization-altering, e.g., a birefringent-scattering, medium. Many biological tissues, such as tendons, muscle, nerve, bone, cartilage and teeth, exhibit birefringence due to their linear or fibrous structure. Birefringence causes the polarization state of light to be  
25 altered (e.g., rotated) in a prescribed manner upon reflection. Skin is another birefringent medium. Collagen contained in skin is a weakly birefringent material. At temperatures between 56-65 °C, collagen denatures and loses its birefringence. Thus, by detecting induced changes in the polarization state of light  
30 reflected from a skin sample, an image representing the regions of skin where thermal injury occurs can be identified. FIG. **3B** shows an alternative embodiment of the first angled-dual-axis confocal scanning system of the present invention, pertaining to applications where polarized light is used to probe a  
35 birefringent-scattering (or other polarization-altering) medium. By way of example, angled-dual-axis confocal scanning system **350** comprises an angled-dual-axis confocal scanning microscope (ADACSM) **351**, a polarized light source **352**, and a polarizing

beamsplitter **353**. As in FIG. **3A**, angled-dual-axis confocal scanning microscope **351** is in a simplified schematic form of one of the embodiments shown in FIGS. **2A-2B**, with first and second optical fibers **103**, **104** being polarization maintaining fibers capable of supporting two orthogonal polarizations. Polarized light source **352** is optically coupled to a second end **354** of first optical fiber **103**, to provide an illumination beam **117** with **P-polarization** to angled-dual-axis confocal scanning microscope **351**. Polarizing beamsplitter **353** is optically coupled to a second end **355** of second optical fiber **104**, to receive an observation beam **118** with orthogonal **P-polarization** and **S-polarization** collected by angled-dual-axis confocal scanning microscope **351** from confocal overlapping volume **121** within a birefringent-scattering (or other polarization-altering) object **120**. The birefringent (or other polarization-altering) "scatterers" in object **120** emanate light whose polarization is altered (e.g., rotated) with respect to the polarization of the illumination beam. Such a rotated polarization can be represented in two orthogonal components, e.g., **P-polarization** and **S-polarization**. Polarizing beamsplitter **353** separates **P-polarization** and **S-polarization** by routing them to two separate optical detectors **356**, **357** respectively, such that an image representing these birefringent (or other polarization-altering) scatterers can be obtained.

25

In the embodiment of FIG. **3B**, polarized light source **352** can be a laser source, such as a semiconductor optical amplifier, an optical fiber amplifier, a semiconductor laser, a diode-pumped solid state laser, or any other fiber-coupled polarized light source known in the art. Polarized light source **352** can also be an assembly consisting of an unpolarized light source optically coupled to a polarizer, such that polarized light is produced and transmitted from the assembly to angled-dual-axis confocal scanning microscope **351** as an illumination beam. Optical detectors **356**, **357** can be PIN diodes, avalanche photo diodes, or photomultiplier tubes. Polarizing beamsplitter **353** can be a polarizing beamsplitter evanescent wave optical fiber coupler, for instance. As such, angled-dual-axis confocal scanning

35

system **350** is suited for applications in which high resolution and fast imaging of birefringent (or other polarization-altering) media is required. Those skilled in the art can implement this angled-dual-axis confocal scanning system of the present invention in a way suitable for a given application.

It should be pointed out that although optical fibers, particularly single-mode fibers, are preferable as optical coupling means between various optical elements in this invention, and are used throughout this specification wherever optical coupling is called for, other suitable optical coupling means can be alternatively implemented in various angled-dual-axis confocal scanning systems of this invention, without deviating from the principle and the scope of the present invention.

FIG. 4 depicts an exemplary embodiment of an angled-dual-axis confocal scanning module according to the present invention. Angled-dual-axis confocal scanning module **400** comprises an angled-dual-axis confocal scanning microscope (ADACSM) **401** and a three-port optical circulator **402**. For the purpose of illustration, angled-dual-axis confocal scanning microscope **401** is in a simplified schematic form of one of the embodiments shown in FIGS. **2A-2B**, although any other embodiment in accordance with the present invention can also be used. Three-port optical circulator **402** is a non-reciprocal device, which couples light incident on **port-1** to **port-2**, and light incident on **port-2** to **port-3** with high transmission. Whereas light traveling in a reversed order encounters high isolation. High isolation also exists between **port-1** and **port-3**. For instance, current commercial fiber-coupled circulators known in the art have insertion losses (**port-1** to **2**, and **port-2** to **3**) less than 0.7 dB, and isolation (**port-3** to **2**, **port-2** to **1**) greater than 50 dB. Angled-dual-axis confocal scanning module **400** is configured such that **port-3** of optical circulator **402** is optically coupled to a second end **403** of first optical fiber **103**; **port-1** of optical circulator **402** is optically coupled to a second end **404** of second optical fiber **104**; and **port-2** serves



as a bi-directional input/output port. In operation, an illumination beam **117** transmitted to **port-2** is passed into **port-2** of optical circulator **402** and then coupled to fiber end **403** of angled-dual-axis confocal scanning microscope **401** in nearly its entirety; and an observation beam **118** collected by angled-dual-axis confocal scanning microscope **401** from confocal overlapping volume **121** within object **120** is delivered to **port-1** via fiber end **404** and then routed to **port-2** of optical circulator **402**, to be further utilized or detected in nearly its entirety. As such, angled-dual-axis confocal scanning module **400** of the present invention provides a modular, power-efficient, angled-dual-axis confocal scanning device with a single input/output port, and can be readily incorporated in many optical systems, as the following exemplary embodiments illustrate.

FIGS. **5A-5B** show simplified schematic diagrams of second and third angled-dual-axis confocal scanning systems incorporating an angled-dual-axis confocal scanning module of the present invention. Depicted in FIG. **5A** is the second angled-dual-axis confocal scanning system **500**, comprising an angled-dual-axis confocal scanning module **501**, a self-detecting laser source **502**, a third optical fiber **503**, and an optical detector **504**. By way of example, angled-dual-axis confocal scanning module **501** is in the form of the embodiment shown in FIG. **4**, although any other embodiment in accordance with the present invention can be alternatively implemented. Laser source **502** is equipped with first output aperture **505** and second output aperture **506**. Third optical fiber **503** is optically coupled to first output aperture **505** of laser source **502** on one end and to **port-2** of angled-dual-axis confocal scanning module **501** on the other, such that an illumination beam **117** emitted from first output aperture **505** of laser source **502** is transmitted to angled-dual-axis confocal scanning microscope module **501** through **port-2**, and an observation beam **118** collected by angled-dual-axis confocal scanning module **501** from confocal overlapping volume **121** within object **120** is in turn back coupled to laser source **502** again via first output aperture **505**. The feedback into

laser source **502** of observation beam **118** emanated from object **120** alters the intensity as well as the modes supported by the laser cavity, and the resulting changes are detected by optical detector **504** optically coupled to second output aperture **506** of laser source **502**. The presence of non-reciprocal optical circulator **402** in angled-dual-axis confocal scanning module **501** enables nearly 100% of illumination beam **117** from laser source **502** to be delivered to angled-dual-axis confocal scanning microscope **401**, as well as nearly 100% of observation beam **118** collected by angled-dual-axis confocal scanning microscope **401** to be back coupled to laser source **502**, hence maximizing the signal-to-noise ratio in detection. The use of self-detecting laser source **502**, both as a light source and as a detector, further simplifies the structure of this angled-dual-axis confocal scanning system.

The self-detecting characteristics of lasers have been advantageously exploited in the art to provide an integrated light source and detector, as demonstrated in US Patents 5,887,009 and 5,563,710, by R. Juskaitis et al. in "Semiconductor Laser Confocal Microscopy", Applied Optics, 33 (4), pp.578 (1994), and by R. Juskaitis et al. in "Compact confocal interference microscopy", Optics Communications, 109, pp.167 (1994), all incorporated herein by reference. A great deal of effort has also been devoted to eliminate such feedback effects; in fact, optical isolators with non-reciprocal optical elements such as Faraday rotators are designed to eliminate or block the back-coupling of light. The effects of laser feedback and the resulting perturbations of laser power and frequency depend on many conditions including laser cavity parameters, and a complete theory is still lacking at the present time. In the present invention, the self-detecting laser source can be a fiber laser, a semiconductor laser, or a diode pumped solid state laser. A fiber-based laser system, such as the fiber laser disclosed by the inventors of this application in US Patent 5,887,009, may be used to take advantage of a wide range of possible designs and laser cavity parameters to optimize the laser self-detecting properties. A

semiconductor laser may also be desirable for constructing a low cost device.

Angled-dual-axis confocal scanning system **500** in FIG. **5A** further comprises a frequency shifting means (or a phase modulator) in the form of frequency shifter **507** optically coupled to third optical fiber **503**, such that the frequency of observation beam **118** is shifted before being back coupled to laser source **502**. Frequency shifter **507** can be alternatively coupled to first optical fiber **103**, or second optical fiber **104**, for the same purpose of shifting the frequency of observation beam **118**. The feedback of the frequency-shifted (or phase-modulated) observation beam to laser source **502** results in the laser's output beam being modulated at a beat frequency, thus allowing more sensitive heterodyne detection.

FIG. **5B** depicts the third angled-dual-axis confocal scanning system of the present invention, pertaining to the situation where the self-detecting laser is equipped with only one output aperture. Angled-dual-axis confocal scanning system **550** comprises an angled-dual-axis confocal scanning module **551**, a beam-splitting means in the form of a fiber-optic coupler **552**, a self-detecting laser source **553** having a single output aperture **554**. By way of example, angled-dual-axis confocal scanning module **551** is in the form of the embodiment shown in FIG. **4**, although any other embodiment in accordance with the present invention can also be implemented. Angled-dual-axis confocal scanning module **551** is optically coupled to fiber-optic coupler **552** by way of a third optical fiber **555**, and fiber-optic coupler **552** is in turn optically coupled to laser source **553**. Fiber-optic coupler **552** directs a portion of an output beam emitted from output aperture **554** of laser source **553** to **port-2** of angled-dual-axis confocal scanning module **551**, providing an illumination beam **117**. An observation beam **118** collected by confocal scanning module **551** from confocal overlapping volume **121** within object **120** is routed back to laser source **553** again via output aperture **554**. Fiber-optic coupler **552** also routes a remainder of the laser's output beam,

which carries the perturbations due to the back coupling of observation beam **118**, to an optical detector **556**. To enhance the back coupling effects, a low-coupling tap coupler, such as a 90/10 fiber-optic coupler, is preferred. To make use of  
5 heterodyne detection, a frequency shifting means (or a phase modulator) in the form of frequency shifter **557** is optically coupled to third optical fiber **555**, such that the frequency of observation beam **118** is shifted before being back coupled to laser source **553**. Frequency shifter **557** can be alternatively  
10 coupled to first optical fiber **103**, or second optical fiber **104**, for the purpose of shifting the frequency of observation beam **118**.

FIGS. **6A-6B** depict simplified schematic diagrams of fourth and  
15 fifth angled-dual-axis confocal scanning systems of the present invention. Shown in FIG. **6A** is the fourth angled-dual-axis confocal scanning system **600** of the present invention, comprising an angled-dual-axis confocal scanning module **601** optically coupled to a second optical circulator **602** by way of  
20 a third optical fiber **603**, and a light source **604** optically coupled to second optical circulator **602** by way of a fourth optical fiber **605**. For the purpose of illustration, angled-dual-axis confocal scanning module **601** is in the form of the embodiment shown in FIG. **4**, although any other embodiment in  
25 accordance with the present invention can be alternatively implemented. Third optical fiber **603** is optically coupled to **port-2** of second optical circulator **602** on one end and to **port-2** of angled-dual-axis confocal scanning module **601** on the other. Fourth optical fiber **605** in turn optically couples  
30 **port-1** of second optical circulator **602** to light source **604**. In operation, an illumination beam **117** emitted from light source **604** is transmitted to **port-1** of and in turn passed onto **port-2** of second optical circulator **602**, and further transmitted to **port-2** of angled-dual-axis confocal scanning  
35 module **601**. An observation beam **118** collected by angled-dual-axis confocal scanning module **601** from confocal overlapping volume **121** within object **120** is routed back to **port-2** of and in

turn directed to **port-3** of second optical circulator **602**, to which an optical detector **606** is optically coupled.

In the aforementioned angled-dual-axis confocal scanning system, light source **604** can be a fiber laser, a semiconductor laser, a diode-pumped solid state laser, or a continuous wave or pulsed fiber-coupled light source known in the art. A skilled artisan can implement an appropriate light source suitable for a given application. Furthermore, the non-reciprocal nature of second optical circulator **602** allows nearly 100% of observation beam **118** to be used for detection, thereby maximizing the signal-to-noise ratio.

The embodiment shown in FIG. **6A** can be further modified into an interferometer configuration, such that the observation beam is combined with a portion of the output beam from the light source to create coherent interference. This can be achieved by inserting a beam-splitting means, such as a fiber-optic coupler or a beamsplitter, between the light source and the second optical circulator in the above embodiment. FIG. **6B** depicts the fifth angled-dual-axis confocal scanning system **650** of the present invention, comprising an angled-dual-axis confocal scanning module **651**, a second optical circulator **652**, a beam-splitting means in the form of first fiber-optic coupler **653**, and a light source **654**. For illustration purposes, angled-dual-axis confocal scanning module **651** is in the form of the embodiment shown in FIG. **4**, although any other embodiment in accordance with the present invention can also be implemented. A third optical fiber **655** optically couples **port-2** of angled-dual-axis confocal scanning module **651** to **port-2** of second optical circulator **652**. First fiber-optic coupler **653** is in optical communication with light source **654** and second optical circulator **652**, such that it diverts a portion of an output beam from light source **654** to **port-1** of second optical circulator **652** and a remainder of the output beam to a reference optical fiber **656**, thereby creating an illumination beam **117** and reference beam from the same parent beam. Illumination beam **117** is in turn passed into **port-2** of second

optical circulator **652**, and further transmitted to **port-2** of angled-dual-axis confocal scanning module **651** by way of third optical fiber **655**. An observation beam **118** collected by angled-dual-axis confocal scanning module **651** from confocal overlapping volume **121** within object **120** is routed back to **port-2** of and in turn passed onto to **port-3** of second optical circulator **652**, and further directed to a detection optical fiber **657**. First, second, third, reference and detection fibers **103**, **104**, **655**, **656**, **657** have optical path lengths so selected to ensure optical coherence between the reference and observation beams. Reference optical fiber **656** and detection fiber **657** are joined by a second fiber-optic coupler **658**, such that a balanced detection scheme can be employed for optimizing signal-to-noise ratio in detection.

15

To implement balanced detection, a frequency shifting means (or a phase modulator) in the form of frequency shifter **659** is optically coupled to detection optical fiber **657** for shifting the frequency of the observation beam, such that a heterodyne beat frequency is produced between the unshifted reference beam and the shifted observation beam at second fiber-optic coupler **658** and thus detected by two optical detectors **663**, **664** at the two outputs of second fiber-optic coupler **658**. Frequency shifter **659** can be alternatively coupled to first optical fiber **103**, second optical fiber **104**, third optical fiber **655**, or disposed between first fiber-optic coupler **653** and **port-1** of second optical circulator **652**, for the same purpose of shifting the frequency of the observation beam. Moreover, frequency shifter **659** can be optically coupled to reference optical fiber **656** for shifting the frequency of the reference beam, such that a heterodyne beat frequency is produced between the shifted reference beam and the unshifted observation beam at the two outputs of fiber-optic coupler **658**. The underlying principle of balanced detection and its advantages in fiber-optic interferometers are well known in the art, as described by Rollins et al. in "Optimal interferometer designs for optical coherence tomography", Optics Letters, 24(21), pp. 1484 (1999), and by Podoleanu in "Unbalanced versus balanced operation in an

35

optical coherence tomography system", Applied Optics, 39(1), pp. 173 (2000), incorporated herein by reference.

Angled-dual-axis confocal scanning system **650** in FIG. **6B**  
5 further comprises an adjustable optical delay device **660**  
optically coupled to reference optical fiber **656**, serving to  
maintain coherent interference between the reference and  
observation beams. Adjustable Optical delay device **660** can be  
alternatively coupled to detection optical fiber **657**, or  
10 anywhere else along the light path, for achieving the same  
purpose. In applications where light source **654** has a short  
coherence length, then delay device **660** can be adjusted such  
that only single-scattered light in observation beam **118** is  
coherent with the reference beam at second fiber-optic coupler  
15 **658** and multiple-scattered light, which traverses over a larger  
optical path length in observation beam **118**, does not  
contribute to the coherent interference, therefore providing  
further filtering of multiple-scattered light.

20 To further increase the signal-to-noise ratio in detection of  
weak optical signals, an optical amplifier **661**, such as a two-  
port fiber amplifier or semiconductor optical amplifier, is  
optically coupled to detection optical fiber **657** in the  
embodiment of FIG. **6B**, to boost up the power of the  
25 observation beam. Optical amplifier **661** can be alternatively  
coupled to second optical fiber **104**, for the purpose of  
amplifying the observation beam. An amplified observation beam  
allows faster scanning rates and consequently higher pixel  
rates without appreciable loss in the signal-to-noise ratio,  
30 because a shorter integration time per pixel of an image is  
required in data collection. The implementation of balanced  
detection in this case also allows subtraction of optical  
amplifier noise, since most of spontaneous emission of optical  
amplifier **661** would not occur at the heterodyne beat frequency  
35 described above.

Light source **654** in FIG. **6B** can be an optical fiber amplifier,  
a semiconductor optical amplifier, a fiber laser, a

semiconductor laser, a diode-pumped solid state laser, or a continuous wave or pulsed broadband OCT light source having a short coherence length, as is well known in the art. For biological or medical applications, the light source should  
5 produce light in the wavelength range of about 0.8 to 1.6 microns, since biological tissues are particularly transparent in this range. The various optical fibers are preferably of single-mode type, for single-mode fibers offer the advantage of simplicity and automatic assurance of the mutual spatial  
10 coherence of the observation and reference beams upon detection. If a polarized light beam is provided by light source **654**, first fiber-optic coupler **653** should be a polarization maintaining coupler. Various optical fibers in the system should be polarization maintaining fibers, capable of  
15 supporting two orthogonal polarizations. First and second optical circulators **402**, **652** should also be polarization maintaining. In this case, the reference and observation beams can be brought into the same polarization by rotating either reference optical fiber **656**, or detection optical fiber **657**,  
20 before coupling it to second fiber-optic coupler **658**. Alternatively, a polarization rotation means, such as a Faraday rotator, can be coupled to either reference optical fiber **656**, or detection optical fiber **657**, such that the reference and observation beams have substantially the same polarization when  
25 combined. Furthermore, second fiber-optic coupler **658** should be a polarization maintaining fiber coupler to optimally mix the polarized observation and reference beams. All in all, by carefully controlling the polarizations of the beams in angled-dual-axis confocal scanning system **650**, the single-to-noise  
30 ratio of detection can be enhanced.

In the angled-dual-axis confocal scanning systems described above, fiber-optic couplers are used to serve as beam-splitting means. Optical fibers, preferably single-mode fibers, are  
35 employed for the purpose of providing optical coupling. Optical circulators are preferably fiber-coupled circulators. These fiber-optic components, along with the fiber-coupled angled-dual-axis confocal scanning module of the present



invention, enable the confocal scanning systems thus constructed to be all fiber-based systems, hence fully exploiting the flexibility, scalability, ruggedness and economical value afforded by optical fibers.

5

Alternatively, those skilled in the art may substitute the fiber-optic couplers and optical circulators by other types of beam-splitting and beam-routing means, such as assemblies of beamsplitters, prisms, and birefringent elements, and the optical fibers by other types of free space or bulk optical coupling means well known in the art, in the angled-dual-axis confocal scanning systems of the present invention without deviating from the principle and the scope of the present invention. Further, the methods for detection of optical signals and for electronic processing of the detected signals into images are well known in the art. A skilled artisan can make suitable design choices for a given application.

All in all, the angled-dual-axis confocal scanning microscope of the present invention provides many advantages over the prior art systems, most notably: enhanced axial resolution while maintaining a workable working distance and a large field of view, fast and high-precision scanning, low noise, an integrated and scalable structure. Moreover, by using low NA focusing elements (or lenses), the angled-dual-axis confocal scanning microscope of the present invention is capable of minimizing multiple-scattered light, thereby achieving higher sensitivity and larger dynamic range of detection, a capability particularly desirable for imaging within a scattering medium. Additionally, the integration of the angled-dual-axis confocal scanning microscope of the present invention with fiber-optic components and a fiber-coupled laser provides an assembly of fiber-based angled-dual-axis confocal scanning systems that can be particularly powerful tools in biological and medical imaging applications, such as instruments for performing optical coherence microscopy and *in vivo* optical biopsies.

Although the present invention and its advantages have been described in detail, it should be understood that various changes, substitutions, and alternations can be made herein without departing from the principle and the scope of the invention. Accordingly, the scope of the present invention should be determined by the following claims and their legal equivalents.

## CLAIMS

What is claimed is:

- 1 1. An angled-dual-axis confocal scanning system comprising an  
2 angled-dual-axis confocal scanning head, wherein said  
3 angled-dual-axis confocal scanning head comprises:
- 4 a) a first optical fiber having first and second ends,  
5 for providing an illumination beam at said first end;
  - 6 b) a second optical fiber having first and second ends;
  - 7 c) an angled-dual-axis focusing means for focusing said  
8 illumination beam to an illumination focal volume  
9 along an illumination axis within an object and for  
10 receiving an observation beam emanated from an  
11 observation focal volume along an observation axis  
12 within said object such that said observation beam is  
13 focused onto said first end of said second optical  
14 fiber; and
  - 15 d) a scanning means for producing an arc-line scan,  
16 wherein said scanning means is in optical  
17 communication with said focusing means and said  
18 object, wherein said scanning means receives said  
19 illumination beam from said angled-dual-axis focusing  
20 means and directs said illumination beam to said  
21 illumination focal volume within said object, and  
22 wherein said scanning means collects said observation  
23 beam emanated from said observation focal volume and  
24 passes said observation beam to said angled-dual-axis  
25 focusing means;
- 26 wherein said illumination axis and said observation axis  
27 intersect at an angle within said object, such that said  
28 illumination focal volume and said observation focal volume  
29 intersect at a confocal overlapping volume, and wherein  
30 said scanning means is capable of pivoting said

31 illumination and observation beams in such a way that said  
32 illumination axis and said observation axis remain  
33 intersecting at said angle and that said confocal  
34 overlapping volume moves along an arc-line within said  
35 object, thereby producing said arc-line scan.

36

1 2. The angled-dual-axis confocal scanning system of claim 1  
2 further comprising a vertical scanning unit, wherein  
3 said vertical scanning unit comprises:

- 4 a) a translation means mechanically coupled to said  
5 angled-dual-axis confocal scanning head; and  
6 b) a compensation means for ensuring said intersection  
7 of said illumination focal volume and observation  
8 focal volume;

9 wherein said translation means is capable of causing  
10 said angled-dual-axis confocal scanning head to move  
11 relative to said object, whereby a succession of arc-  
12 line scans that progressively deepen into said object is  
13 produced, providing a vertical cross-section scan.

14

1 3. The angled-dual-axis confocal scanning system of claim  
2 2 wherein said compensation means comprises a fluid  
3 filling a space between said scanning means and said  
4 object, wherein said fluid is substantially  
5 transparent to said illumination beam and said  
6 observation beam, and wherein said fluid has an index  
7 of refraction that is substantially the same as an  
8 index of refraction of said object.

9

1 4. The angled-dual-axis confocal scanning system of  
2 claim 3 further comprising a window assembly  
3 interposed between said scanning means and said  
4 fluid for passage of said illumination and  
5 observation beams.

6

- 1           5.    The angled-dual-axis confocal scanning system of  
2                    claim 4 wherein said window assembly comprises a  
3                    substantially transparent flat window.  
4
- 1           6.    The angled-dual-axis confocal scanning system of  
2                    claim 4 wherein said window assembly comprises  
3                    first and second substantially transparent flat  
4                    windows in an angled arrangement, such that said  
5                    illumination axis is substantially perpendicular  
6                    to said first flat window and said observation  
7                    axis is substantially perpendicular to said  
8                    second flat window.  
9
- 1           7.    The angled-dual-axis confocal scanning system of  
2                    claim 3 further comprising a transparent window  
3                    interposed between said fluid and said object for  
4                    passage of said illumination and observation beams.  
5
- 1           8.    The angled-dual-axis confocal scanning system of  
2                    claim 3 wherein said fluid is contained in a sealed  
3                    hydraulic system, including a reservoir for  
4                    replenishing and receiving excess fluid in the  
5                    course of vertical cross-section scans.  
6
- 1           9.    The angled-dual-axis confocal scanning system of claim 1  
2                    wherein said angled-dual-axis focusing means comprises  
3                    one or more elements selected from the group consisting  
4                    of refractive lenses, diffractive lenses, GRIN lenses,  
5                    focusing gratings, micro-lenses, holographic optical  
6                    elements, curved mirrors, and binary lenses.  
7
- 1           10.   The angled-dual-axis confocal scanning system of claim  
2                    9 wherein said angled-dual-axis focusing means  
3                    comprises a single element, where said element

4 provides said illumination axis and said observation  
5 axis.

6

1 11. The angled-dual-axis confocal scanning system of claim  
2 9 wherein said angled-dual-axis focusing means  
3 comprises an illumination focusing element and an  
4 observation focusing element, wherein said  
5 illumination focusing element provides said  
6 illumination axis, and wherein said observation  
7 focusing element provides said observation axis.

8

1 12. The angled-dual-axis confocal scanning system of  
2 claim 11 wherein said illumination focusing element  
3 and said observation focusing element are of the  
4 same type, comprising a focusing element selected  
5 from the group consisting of refractive lenses,  
6 diffractive lenses, GRIN lenses, micro-lenses,  
7 binary lenses, and curved mirrors.

8

1 13. The angled-dual-axis confocal scanning system of  
2 claim 12 wherein said focusing element has a  
3 numerical aperture (NA) in the range of 0.1 and  
4 0.4.

5

1 14. The angled-dual-axis confocal scanning system of  
2 claim 11 further comprising a first collimating  
3 lens, wherein said first collimating lens receives  
4 said illumination beam from said first end of said  
5 first optical fiber and passes a substantially  
6 collimated illumination beam to said illumination  
7 focusing element.

8

1 15. The angled-dual-axis confocal scanning system of  
2 claim 14 further comprising a second collimating  
3 lens, wherein said second collimating lens

4 receives said observation beam from said  
5 observation focusing element and focuses said  
6 observation beam to said first end of said second  
7 optical fiber.  
8

1 16. The angled-dual-axis confocal scanning system of claim 1  
2 wherein said scanning means comprises one or more  
3 elements selected from the group consisting of scanning  
4 mirrors, reflectors, acousto-optic deflectors, electro-  
5 optic deflectors, mechanical scanning mechanisms, and  
6 Micro-Electro-Mechanical-Systems (MEMS) scanning micro-  
7 mirrors.  
8

1 17. The angled-dual-axis confocal scanning system of claim  
2 16 wherein said scanning means comprises a single  
3 scanning mirror, wherein said scanning mirror is  
4 substantially flat and can be pivoted about one axis.  
5

1 18. The angled-dual-axis confocal scanning system of  
2 claim 17 wherein said scanning mirror is a single  
3 silicon micro-machined mirror.  
4

1 19. The angled-dual-axis confocal scanning system of claim  
2 16 wherein said scanning means comprises two scanning  
3 mirrors that are substantially coplanar, wherein said  
4 scanning mirrors are substantially flat and can co-  
5 rotate substantially about one common axis.  
6

1 20. The angled-dual-axis confocal scanning system of  
2 claim 19 wherein said scanning mirrors are silicon  
3 micro-machined mirrors.  
4

1 21. The angled-dual-axis confocal scanning system of claim  
2 16 wherein said scanning means comprises two scanning  
3 mirrors, wherein each of said scanning mirrors is

4 substantially flat and can be pivoted about one or  
5 more axes, and wherein said scanning mirrors are  
6 configured such that they can be operated in  
7 substantially synchronous motion.  
8

1 22. The angled-dual-axis confocal scanning system of  
2 claim 21 wherein said scanning mirrors are silicon  
3 micro-machined mirrors.  
4

1 23. The angled-dual-axis confocal scanning system of claim 1  
2 wherein said angled-dual-axis confocal scanning head is  
3 mechanically coupled to a substrate.  
4

1 24. The angled-dual-axis confocal scanning system of claim  
2 23 wherein said substrate comprises a silicon  
3 substrate etched with V-grooves.  
4

1 25. The angled-dual-axis confocal scanning system of claim 1  
2 wherein either of said first and second optical fibers  
3 comprises an element selected from the group consisting  
4 of single-mode fibers, polarization maintaining fibers,  
5 multi-mode fibers, and birefringent fibers.  
6

1 26. The angled-dual-axis confocal scanning system of claim  
2 25 wherein each of said first and second optical  
3 fibers comprises a single-mode fiber.  
4

1 27. The angled-dual-axis confocal scanning system of claim 1  
2 wherein said observation beam comprises reflected light  
3 emanated from said confocal overlapping volume within  
4 said object.  
5

1 28. The angled-dual-axis confocal scanning system of claim 1  
2 wherein said observation beam comprises fluorescent



3 light emanated from said confocal overlapping volume  
4 within said object.

5

1 29. The angled-dual-axis confocal scanning system of claim 1  
2 wherein said illumination focal volume and said  
3 observation focal volume are diffraction-limited,  
4 determined by main lobes of said illumination beam's  
5 point-spread function and said observation beam's point-  
6 spread function.

7

1 30. The angled-dual-axis confocal scanning system of claim  
2 29 wherein said confocal overlapping volume is  
3 diffraction-limited.

4

1 31. The angled-dual-axis confocal scanning system of claim 1  
2 wherein said illumination beam is a polarized beam, and  
3 wherein first and second optical fibers are polarization  
4 maintaining fibers, capable of supporting two orthogonal  
5 polarizations.

6

1 32. The angled-dual-axis confocal scanning system of claim 1  
2 further comprising a light source optically coupled to  
3 said second end of said first optical fiber.

4

1 33. The angled-dual-axis confocal scanning system of claim  
2 32 wherein said light source comprises an element  
3 selected from the group consisting of optical fiber  
4 amplifiers, fiber lasers, semiconductor optical  
5 amplifiers, semiconductor lasers, and diode-pumped  
6 solid state lasers.

7

1 34. The angled-dual-axis confocal scanning system of claim  
2 32 wherein said light source comprises a polarized  
3 light source, and wherein said second end of said

4 second optical fiber is optically coupled to a  
5 polarizing beamsplitter.  
6

1 35. The angled-dual-axis confocal scanning system of  
2 claim 34 further comprising two optical detectors,  
3 optically coupled to said polarizing beamsplitter.  
4

1 36. The angled-dual-axis confocal scanning system of claim 1  
2 further comprising one or more optical detectors  
3 optically coupled to said second end of said second  
4 optical fiber.  
5

1 37. The angled-dual-axis confocal scanning system of claim  
2 36 wherein said one or more optical detectors comprise  
3 one or more elements selected from the group  
4 consisting of PIN diodes, avalanche photo diodes, and  
5 photomultiplier tube detectors.  
6

1 38. The angled-dual-axis confocal scanning system of claim 1  
2 further comprising a first optical circulator having  
3 first, second, and third ports, wherein said third port  
4 is optically coupled to said second end of said first  
5 optical fiber, wherein said first port is optically  
6 coupled to said second end of said second optical fiber,  
7 and wherein said second port provides a bi-directional  
8 input/output port.  
9

1 39. The angled-dual-axis confocal scanning system of claim  
2 38 further comprising a self-detecting laser source  
3 having first and second output apertures, wherein said  
4 first output aperture is optically coupled to said  
5 second port of said first optical circulator, and  
6 wherein said second output aperture is optically  
7 coupled to an optical detector.  
8

- 1           40. The angled-dual-axis confocal scanning system of  
2           claim 39 wherein said self-detecting laser source  
3           comprises an element selected from the group  
4           consisting of fiber lasers, semiconductor lasers,  
5           and diode-pumped solid state lasers.  
6
- 1           41. The angled-dual-axis confocal scanning system of  
2           claim 39 further comprising a frequency shifting  
3           means optically coupled to said second optical  
4           fiber, for shifting the frequency of said  
5           observation beam.  
6
- 1           42. The angled-dual-axis confocal scanning system of  
2           claim 39 further comprising a frequency shifting  
3           means optically coupled to said first optical  
4           fiber, for shifting the frequency of said  
5           illumination beam.  
6
- 1           43. The angled-dual-axis confocal scanning system of  
2           claim 39 further comprising a frequency shifting  
3           means in optical communication with said self-  
4           detecting light source and said first optical  
5           circulator, for shifting the frequency of said  
6           observation beam.  
7
- 1           44. The angled-dual-axis confocal scanning system of claim  
2           38 further comprising a self-detecting laser source  
3           having a single output aperture, wherein said output  
4           aperture is optically coupled to said second port of  
5           said first optical circulator via a beam-splitting  
6           means, such that said beam splitting means routes a  
7           portion of an output beam emitted from said output  
8           aperture to said second port of said first optical  
9           circulator and a remainder of said output beam to an  
10          optical detector.

11

- 1 45. The angled-dual-axis confocal scanning system of  
2 claim 44 wherein said self-detecting light source  
3 comprises an element selected from the group  
4 consisting of fiber lasers, semiconductor lasers,  
5 and diode-pumped solid state lasers.  
6
- 1 46. The angled-dual-axis confocal scanning system of  
2 claim 44 wherein said beam-splitting means  
3 comprises an element selected from the group  
4 consisting of fiber-optic couplers, polarization  
5 maintaining fiber-optic couplers, beamsplitters,  
6 and polarizing beamsplitters.  
7
- 1 47. The angled-dual-axis confocal scanning system of  
2 claim 44 further comprising a frequency shifting  
3 means optically coupled to said second optical  
4 fiber, for shifting the frequency of said  
5 observation beam.  
6
- 1 48. The angled-dual-axis confocal scanning system of  
2 claim 44 further comprising a frequency shifting  
3 means optically coupled to said first optical  
4 fiber, for shifting the frequency of said  
5 illumination beam.  
6
- 1 49. The angled-dual-axis confocal scanning system of  
2 claim 44 further comprising a frequency shifting  
3 means in optical communication with said beam-  
4 splitting means and said first optical circulator,  
5 for shifting the frequency of said observation  
6 beam.  
7
- 1 50. The angled-dual-axis confocal scanning system of claim  
2 38 further comprising a second optical circulator

3           having first, second and third ports, wherein said  
4           second port is optically coupled to said second port  
5           of said first optical circulator.  
6

1           51. The angled-dual-axis confocal scanning system of  
2           claim 50 wherein said second port of said second  
3           optical circulator is optically coupled to said  
4           second port of said first optical circulator via a  
5           third optical fiber.  
6

1           52. The angled-dual-axis confocal scanning system of  
2           claim 50 further comprising a light source, wherein  
3           said first port of said second optical circulator  
4           is optically coupled to said light source.  
5

1           53. The angled-dual-axis confocal scanning system of  
2           claim 52 further comprising an optical detector,  
3           optically coupled to said third port of said  
4           second optical circulator.  
5

1           54. The angled-dual-axis confocal scanning system of  
2           claim 52 wherein said light source is optically  
3           coupled to said first port of said second optical  
4           circulator via a beam-splitting means, such that  
5           said beam-splitting means routes a portion of an  
6           output beam emitted from said light source to  
7           said first port of said second optical  
8           circulator, providing said illumination beam, and  
9           wherein a remainder of said output beam provides  
10          a reference beam.  
11

1           55. The angled-dual-axis confocal scanning system  
2           of claim 54 wherein said beam-splitting means  
3           comprises a first fiber-optic coupler, and

4                    wherein said reference beam is routed to a  
5                    reference optical fiber.

6  
1                    56. The angled-dual-axis confocal scanning  
2                    system of claim 55 further comprising a  
3                    detection optical fiber optically coupled to  
4                    said third port of second optical  
5                    circulator, wherein said reference optical  
6                    fiber and said detection optical fiber are  
7                    coupled by a second fiber-optic coupler.

8  
1                    57. The angled-dual-axis confocal scanning  
2                    system of claim 56 further comprising a  
3                    frequency shifting means optically  
4                    coupled to said reference optical fiber,  
5                    for shifting the frequency of said  
6                    reference beam.

7  
1                    58. The angled-dual-axis confocal scanning  
2                    system of claim 56 further comprising a  
3                    frequency shifting means optically  
4                    coupled to said detection optical fiber,  
5                    for shifting the frequency of said  
6                    observation beam.

7  
1                    59. The angled-dual-axis confocal scanning  
2                    system of claim 56 further comprising an  
3                    optical amplifier optically coupled to  
4                    said detection optical fiber, for  
5                    amplifying said observation beam.

6  
1                    60. The angled-dual-axis confocal scanning  
2                    system of claim 56 further comprising an  
3                    adjustable optical delay device optically  
4                    coupled to said detection optical fiber.

OBT-103A/PCT

5

1

2

3

4

5

1

2

3

4

5

6

1

2

3

4

5

6

1

2

3

4

5

6

1

2

3

4

5

6

7

8

1

2

3

61. The angled-dual-axis confocal scanning system of claim 56 further comprising an adjustable optical delay device optically coupled to said reference optical fiber.

62. The angled-dual-axis confocal scanning system of claim 56 further comprising one or more optical detectors, optically coupled to said second fiber optic coupler.

63. The angled-dual-axis confocal scanning system of claim 54 further comprising a frequency shifting means optically coupled to said second optical fiber, for shifting the frequency of said observation beam.

64. The angled-dual-axis confocal scanning system of claim 54 further comprising a frequency shifting means optically coupled to said first optical fiber, for shifting the frequency of said illumination beam.

65. The angled-dual-axis confocal scanning system of claim 54 further comprising a frequency shifting means in optical communication with said second port of said second optical circulator and said second port of said first optical circulator, for shifting the frequency of said observation beam.

66. The angled-dual-axis confocal scanning system of claim 54 further comprising a frequency shifting means optically coupled to said third

4 port of said second optical circulator, for  
5 shifting the frequency of said observation  
6 beam.

7

1 67. The angled-dual-axis confocal scanning system  
2 of claim 54 further comprising an optical  
3 amplifier optically coupled to said second  
4 optical fiber, for amplifying said observation  
5 beam.

6

1 68. The angled-dual-axis confocal scanning system  
2 of claim 54 further comprising an optical  
3 amplifier optically coupled to said third port  
4 of said second optical circulator, for  
5 amplifying said observation beam.

6

1 69. The angled-dual-axis confocal scanning system of claim  
2 2 further comprising a first optical circulator having  
3 first, second, and third ports, wherein said third  
4 port is optically coupled to said second end of said  
5 first optical fiber, and wherein said first port is  
6 optically coupled to said second end of said second  
7 optical fiber.

8

1 70. The angled-dual-axis confocal scanning system of  
2 claim 69 further comprising a self-detecting laser  
3 source having first and second output apertures,  
4 wherein said first output aperture is optically  
5 coupled to said second port of said first optical  
6 circulator, and wherein said second output aperture  
7 is optically coupled to an optical detector.

8

1 71. The angled-dual-axis confocal scanning system of  
2 claim 69 further comprising a self-detecting laser  
3 source having a single output aperture, wherein



4           said output aperture is optically coupled to said  
5           second port of said first optical circulator via a  
6           beam-splitting means, such that said beam splitting  
7           means routes a portion of an output beam emitted  
8           from said output aperture to said second port of  
9           said optical circulator and a remainder of said  
10          output beam to an optical detector.

11  
1           72. The angled-dual-axis confocal scanning system of  
2           claim 69 further comprising a second optical  
3           circulator, wherein a second port of said second  
4           optical circulator is optically coupled to said  
5           second port of said first optical circulator.

6  
1           73. The angled-dual-axis confocal scanning system of  
2           claim 72 further comprising a light source,  
3           wherein a first port of said second optical  
4           circulator is optically coupled to said light  
5           source, and wherein a third port of said second  
6           optical circulator is optically coupled to a  
7           first end of a detection optical fiber.

8  
1           74. The angled-dual-axis confocal scanning system  
2           of claim 73 wherein said light source is  
3           optically coupled to said first port of said  
4           second optical circulator via a beam-splitting  
5           means, such that said beam-splitting means  
6           routes a portion of an output beam emitted  
7           from said light source to said first port of  
8           said second optical circulator and a remainder  
9           of said output beam to a first end of a  
10          reference optical fiber.

11  
1           75. The angled-dual-axis confocal scanning  
2           system of claim 74 wherein said detection

3                   optical fiber and said reference optical  
4                   fiber are coupled by a fiber-optic coupler.  
5

1   76. A method of performing angled-dual-axis confocal scanning  
2    on a sample, comprising:

3    a) transmitting an illumination beam emerging from a  
4       first end of a first optical fiber to an angled-dual-  
5       axis focusing means;

6    b) passing said illumination beam from said angled-dual-  
7       axis focusing means to a scanning means;

8    c) using said scanning means to direct said illumination  
9       beam to an illumination focal volume along an  
10      illumination axis within said sample;

11   d) using said scanning means to collect an observation  
12      beam emanated from an observation focal volume along  
13      an observation axis within said sample, wherein said  
14      illumination axis and said observation axis intersect  
15      at an angle within said sample, such that said  
16      illumination focal volume and said observation focal  
17      volume intersect at a confocal overlapping volume;

18   e) passing said observation beam from said scanning means  
19      to said angled-dual-axis focusing means;

20   f) focusing said observation beam to a first end of a  
21      second optical fiber; and

22   g) pivoting said scanning means in such a way that said  
23      illumination axis and said observation axis remain  
24      intersecting at said angle and that said confocal  
25      overlapping volume moves along an arc-line within said  
26      sample, thereby producing an arc-line scan.  
27

1   77. The method of claim 76 further comprising the step of  
2    moving said first ends of said first and second optical  
3    fibers, said angled-dual-axis focusing means, and said  
4    scanning means in unity relative to said sample and  
5    repeating said step of g), whereby a succession of arc-

6 line scans that progressively deepen into said sample is  
7 produced, providing a vertical cross-section scan.

8  
1 78. The method of claim 77 further comprising the step of  
2 filling a space between said scanning means and said  
3 sample with a fluid, wherein said fluid is  
4 substantially transparent to said illumination beam  
5 and said observation beam, and wherein said fluid has  
6 an index of refraction that is substantially the same  
7 as an index of refraction of said sample, for ensuring  
8 said intersection of said illumination focal volume  
9 and said observation focal volume in the course of  
10 vertical cross-section scans.

11  
1 79. The method of claim 78 further comprising the step  
2 of disposing a window assembly between said  
3 scanning means and said fluid for passage of said  
4 illumination and observation beams.

5  
1 80. The method of claim 78 further comprising the step  
2 of disposing a transparent window between said  
3 fluid and said sample for passage of said  
4 illumination and observation beams.

5  
1 81. The method of claim 76 further comprising the step of  
2 mechanically coupling said first ends of said first and  
3 second fibers, said angled-dual-axis focusing means, and  
4 said scanning means to a substrate.

5  
1 82. The method of claim 76 wherein said scanning means  
2 comprises a flat scanning mirror that can be pivoted  
3 about one axis.

4  
1 83. The method of claim 82 wherein said scanning mirror is  
2 a silicon micro-machined scanning mirror.

3

1 84. The method of claim 76 wherein said scanning means  
2 comprises two flat coplanar scanning mirrors that can  
3 co-rotate substantially about one common axis.

4

1 85. The method of claim 84 wherein said scanning mirrors  
2 are silicon micro-machined scanning mirrors.

3

1 86. The method of claim 76 wherein said scanning means  
2 comprises two flat scanning mirrors, wherein each of  
3 said scanning mirrors can be pivoted about an axis.

4

1 87. The method of claim 86 wherein each of said scanning  
2 mirrors is a silicon micro-machined scanning mirror.

3

1 88. The method of claim 76 wherein said angled-dual-axis  
2 focusing means comprises a single element, where said  
3 element provides said illumination axis and said  
4 observation axis.

5

1 89. The method of claim 76 wherein said angled-dual-axis  
2 focusing means comprises an illumination focusing  
3 element and an observation focusing element, wherein  
4 said illumination focusing element provides said  
5 illumination axis, and wherein said observation focusing  
6 element provides said observation axis.

7

1 90. The method of claim 76 further comprising the step of  
2 coupling a second end of said first optical fiber to a  
3 light source and a second end of said second optical  
4 fiber to an optical detector, such that said  
5 illumination beam is transmitted from said light source  
6 and said observation beam is routed to said optical  
7 detector.

8

1       91. The method of claim 76 further comprising the step of  
2       coupling a second end of said first optical fiber to a  
3       third port of and a second end of said second optical  
4       fiber to a first port of a three-port optical  
5       circulator.

6

1       92. The method of claim 91 further comprising the step of  
2       coupling a second port of said optical circulator to a  
3       first output aperture of a self-detecting light source  
4       and coupling a second output aperture of said self-  
5       detecting light source to an optical detector, such  
6       that said illumination beam is transmitted from said  
7       first output aperture and said observation beam is  
8       back coupled to said first output aperture.

9

1       93. The method of claim 91 further comprising the step of  
2       coupling a second port of said optical circulator to a  
3       second port of an auxiliary three-port optical  
4       circulator, a first port of said auxiliary optical  
5       circulator to a light source, and a third port of said  
6       auxiliary optical circular to a first end of a  
7       detection optical fiber, such that said illumination  
8       beam originates from said light source and said  
9       observation beam is routed to said detection optical  
10      fiber.

11

1       94. The method of claim 93 further comprising the step  
2       of coupling a beam-splitting means between said  
3       light source and said first port of said auxiliary  
4       optical circulator, such that said beam-splitting  
5       means routes a portion of an output beam emitted  
6       from said light source to said first port of said  
7       auxiliary optical circulator, providing said  
8       illumination beam, and a remainder of said output

9 beam to a first end of a reference optical fiber,  
10 providing a reference beam.

11

1 95. The method of claim 94 further comprising the  
2 step of combining and detecting coherent  
3 interference between said reference beam and said  
4 observation beam.

5

1 96. The method of claim 95 further comprising the  
2 step of joining said reference optical fiber  
3 and said detection optical fiber by a fiber-  
4 optic coupler and implementing balanced  
5 detection scheme.

6

1 97. The method of claim 95 further comprising the  
2 step of shifting the frequency of said  
3 observation beam and using heterodyne  
4 detection to detect coherent interference  
5 between said reference beam and said  
6 observation beam.

7

1 98. The method of claim 95 further comprising the  
2 step of shifting the frequency of said  
3 reference beam and using heterodyne detection  
4 to detect coherent interference between said  
5 reference beam and said observation beam.

6

1

2

3

4

5

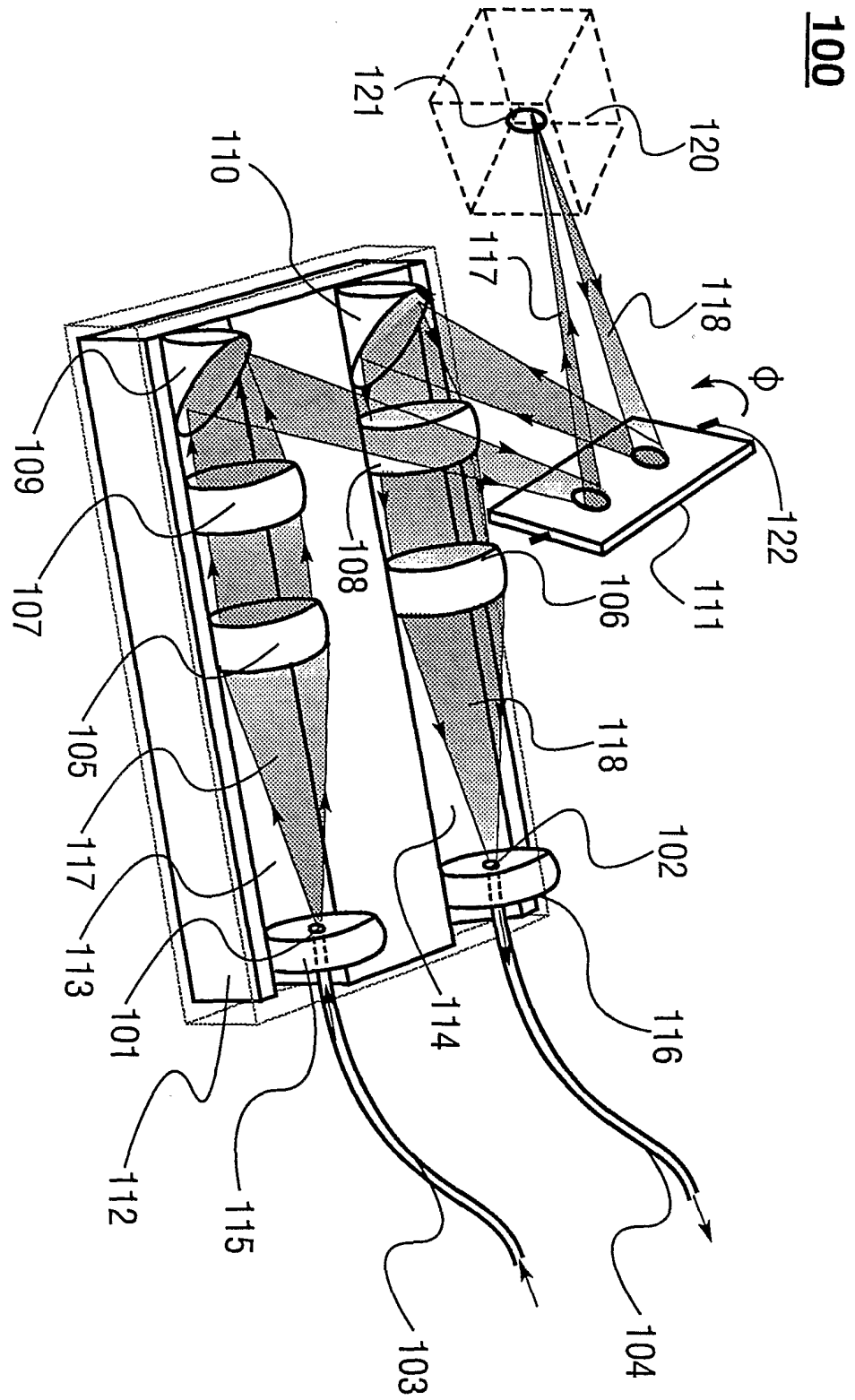

Fig. 1A

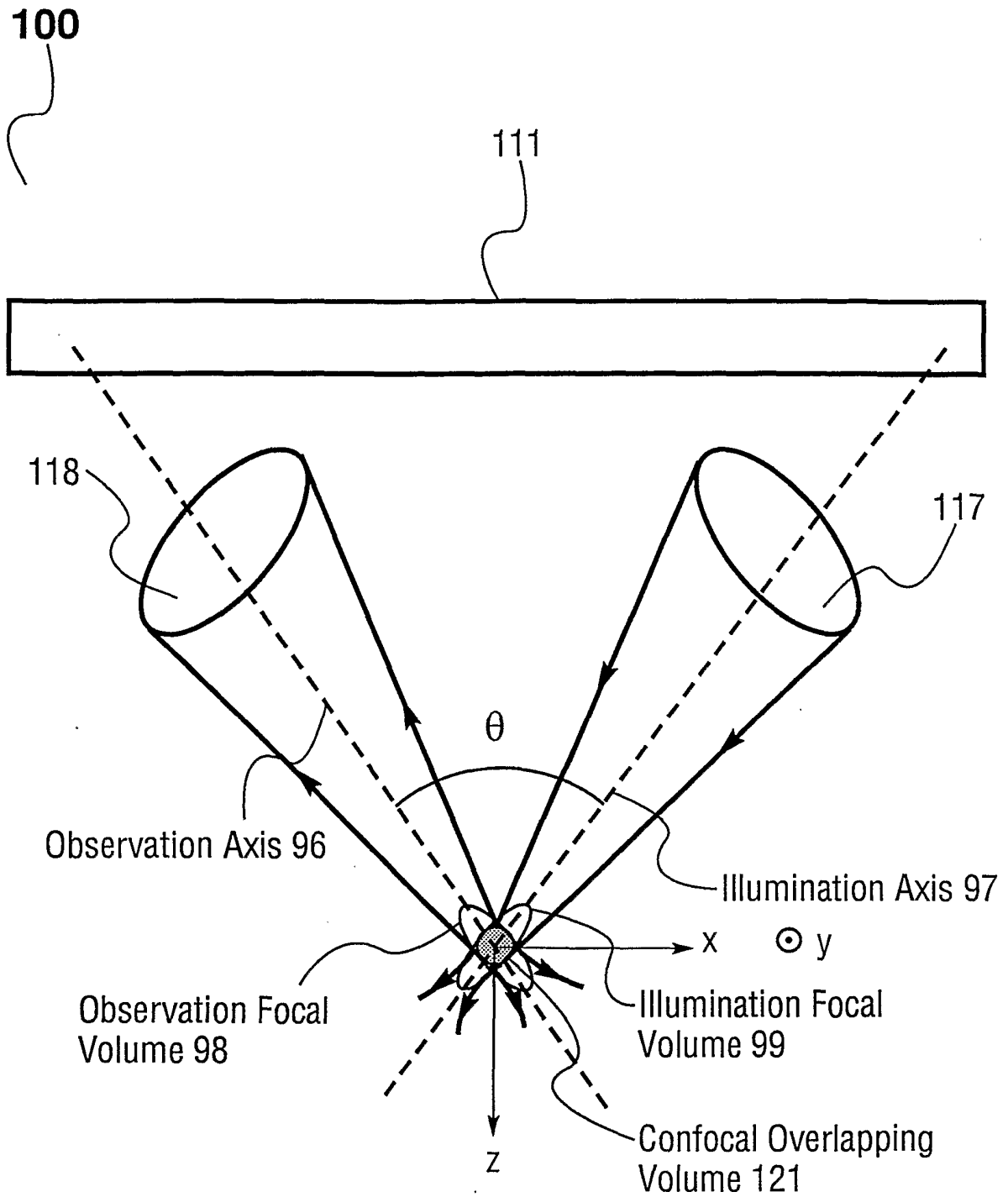
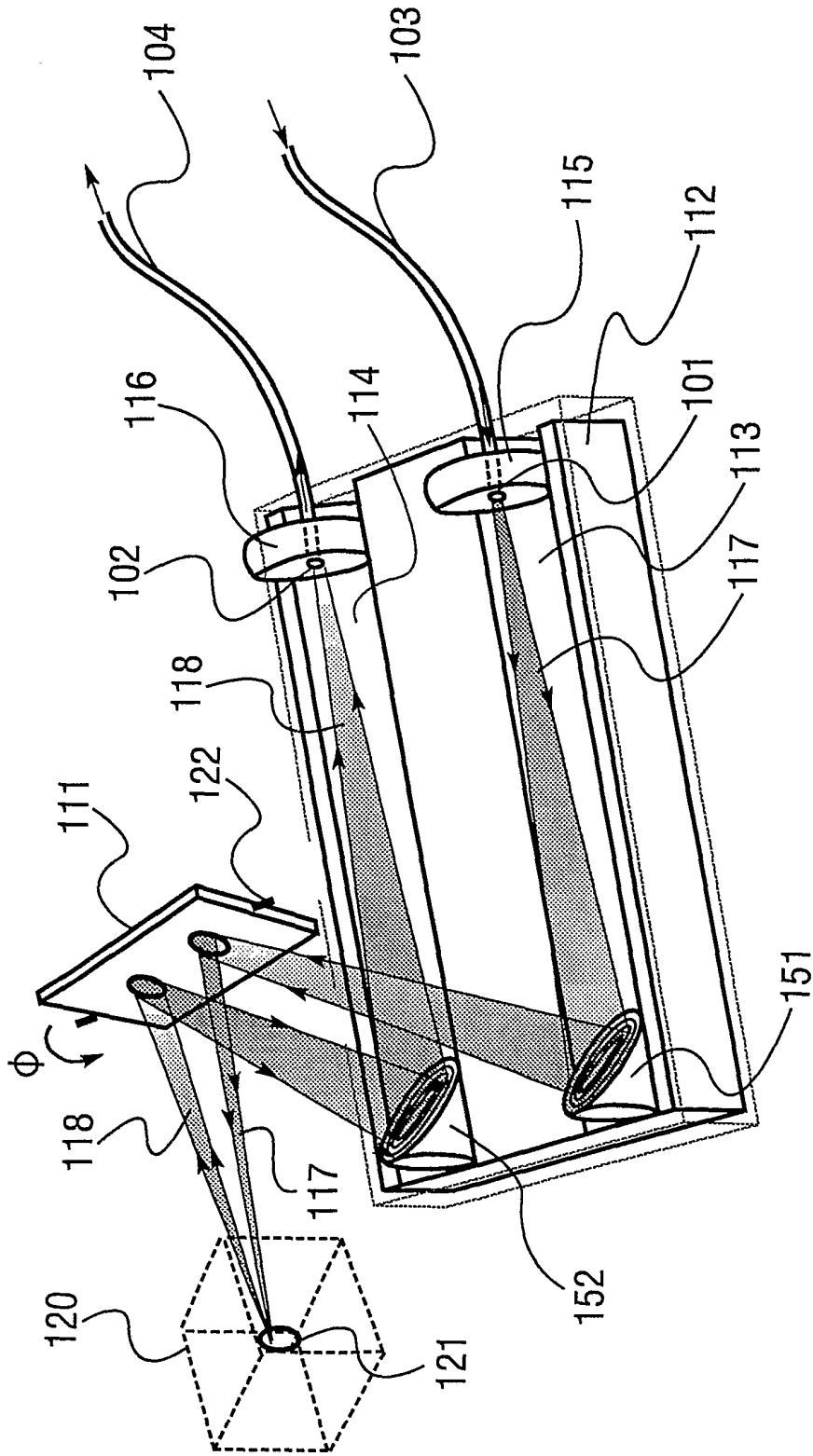

Fig. 1B



150



**Fig. 1C**

**170**

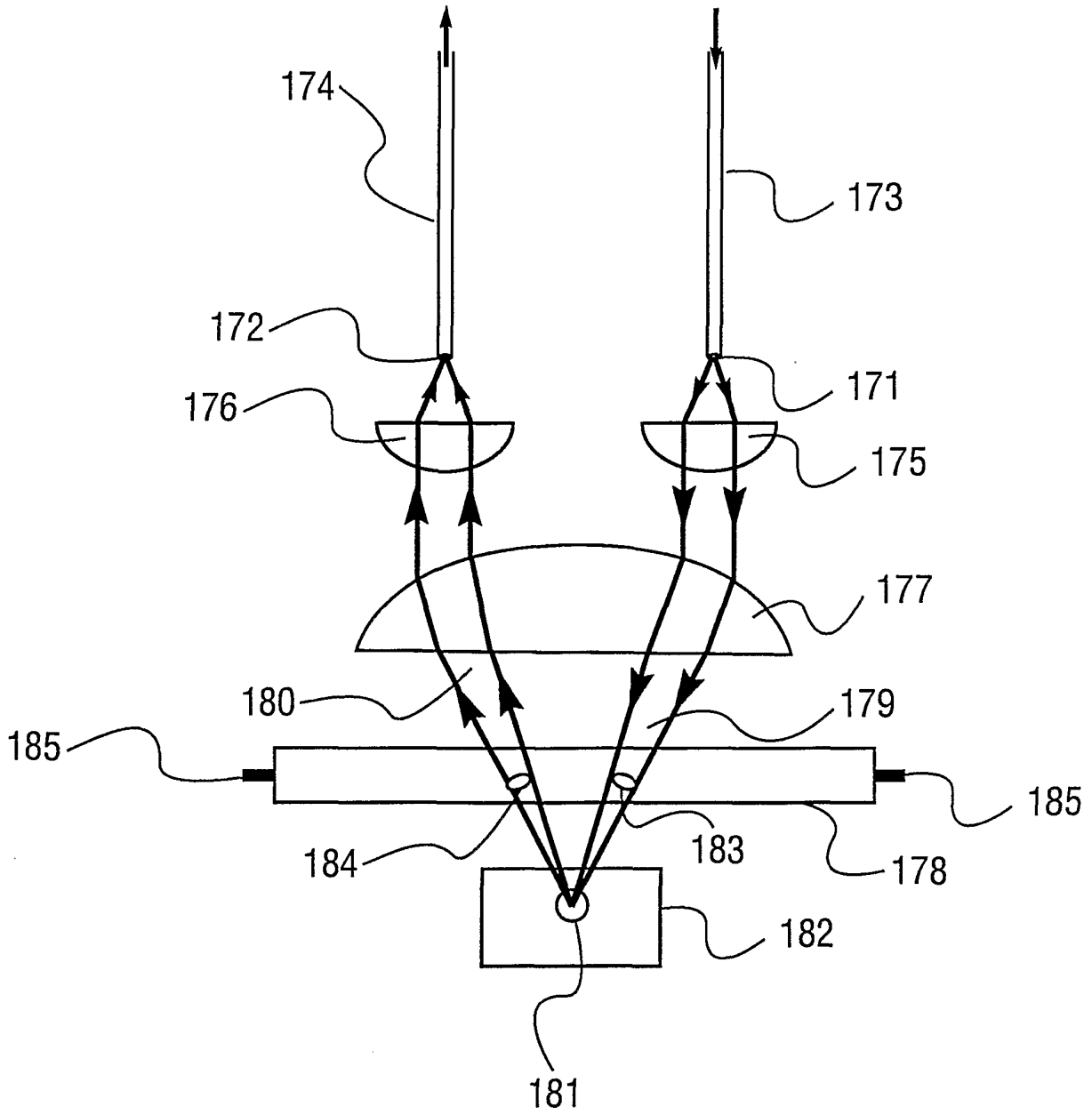

**Fig. 1D**

**200**

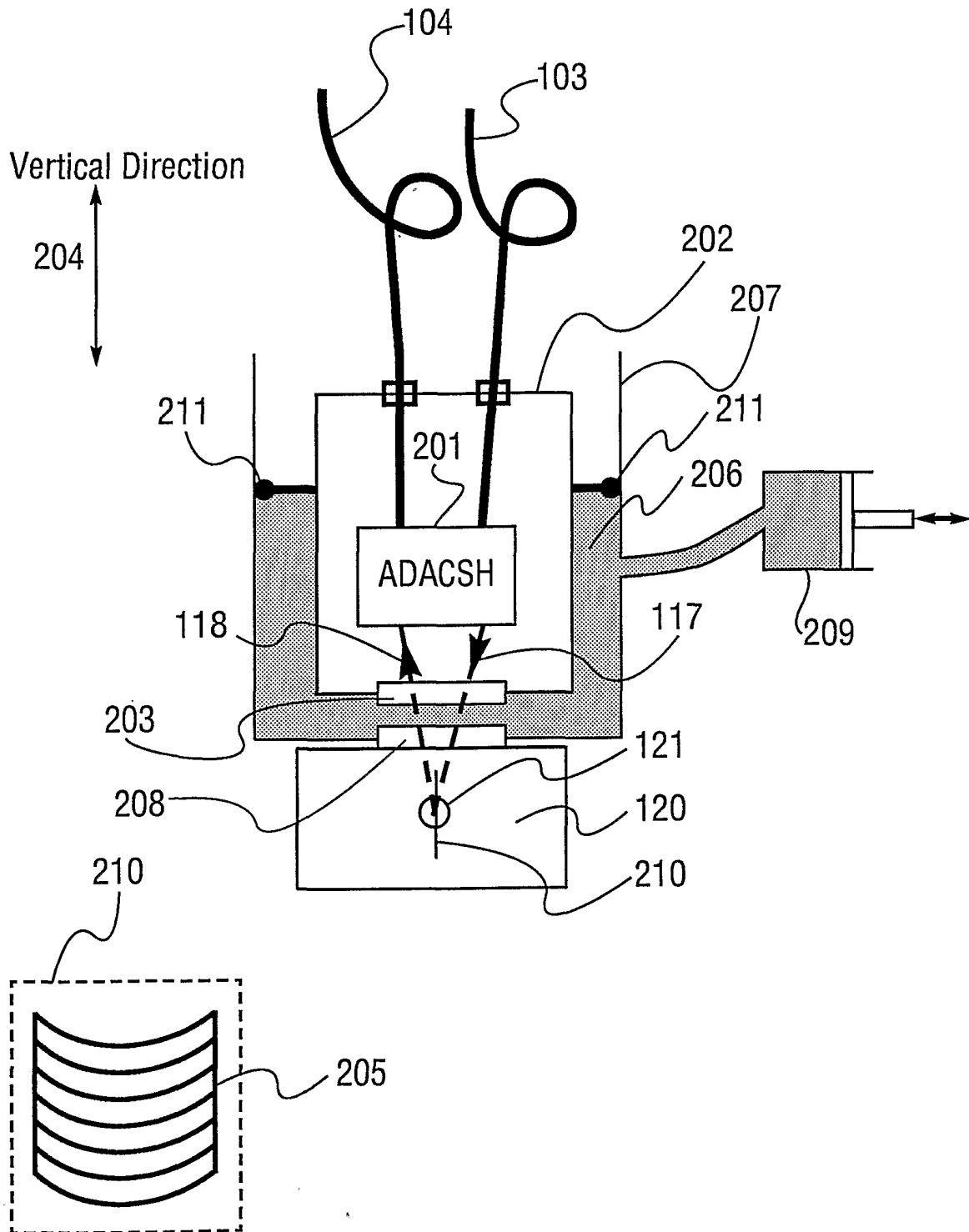

**Fig. 2A**

**250**

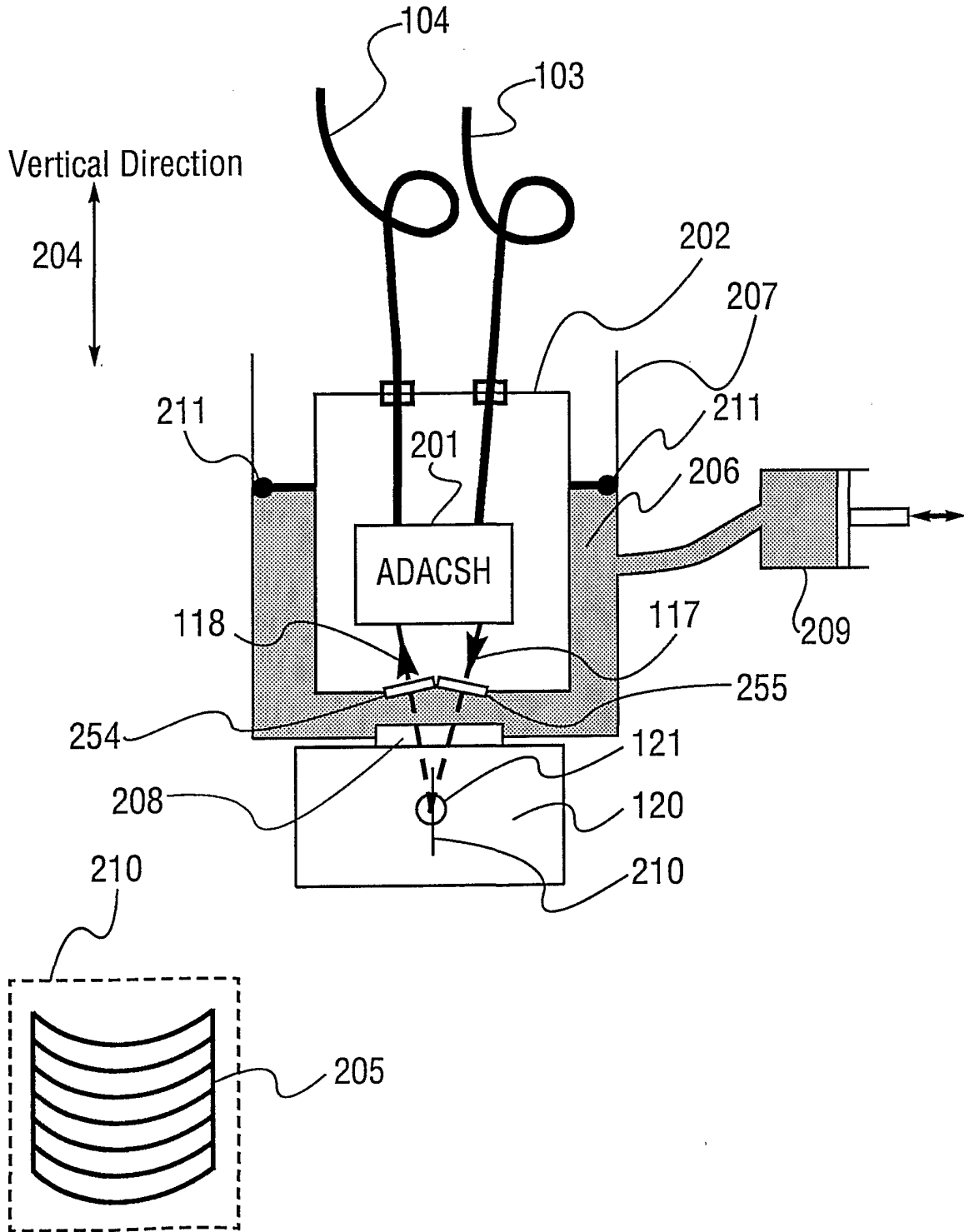

**Fig. 2B**

**300**

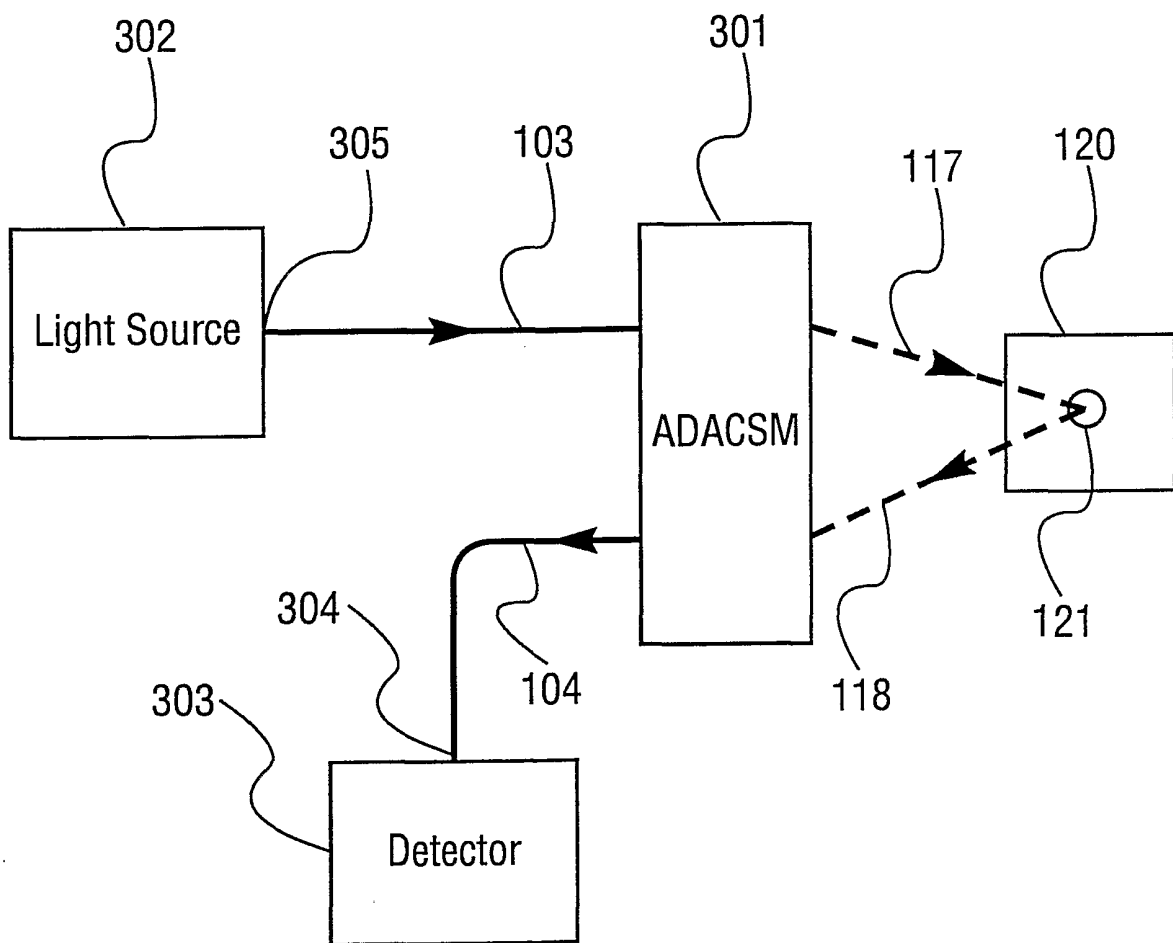

**Fig. 3A**

**350**

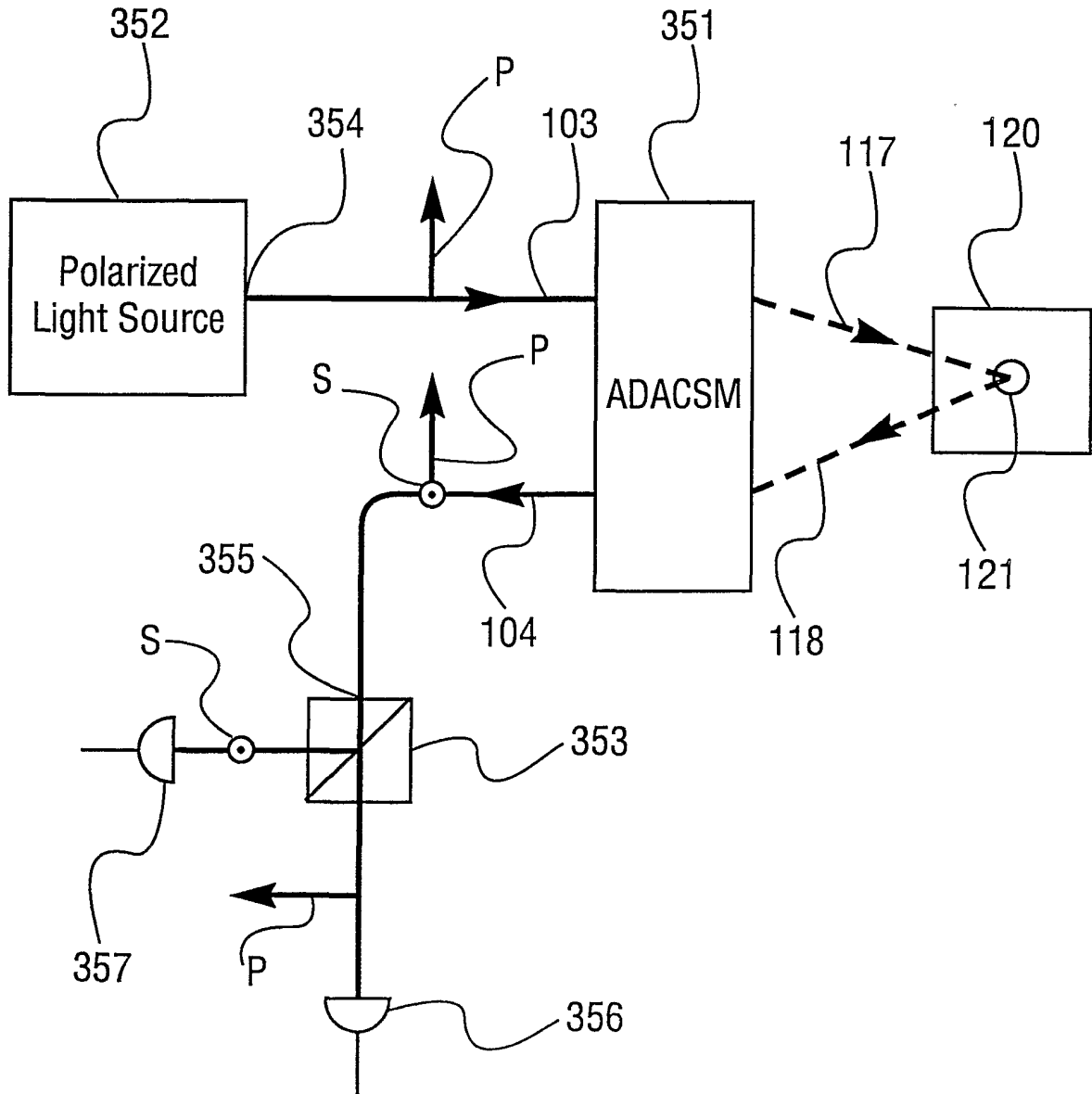

**Fig. 3B**

**400**

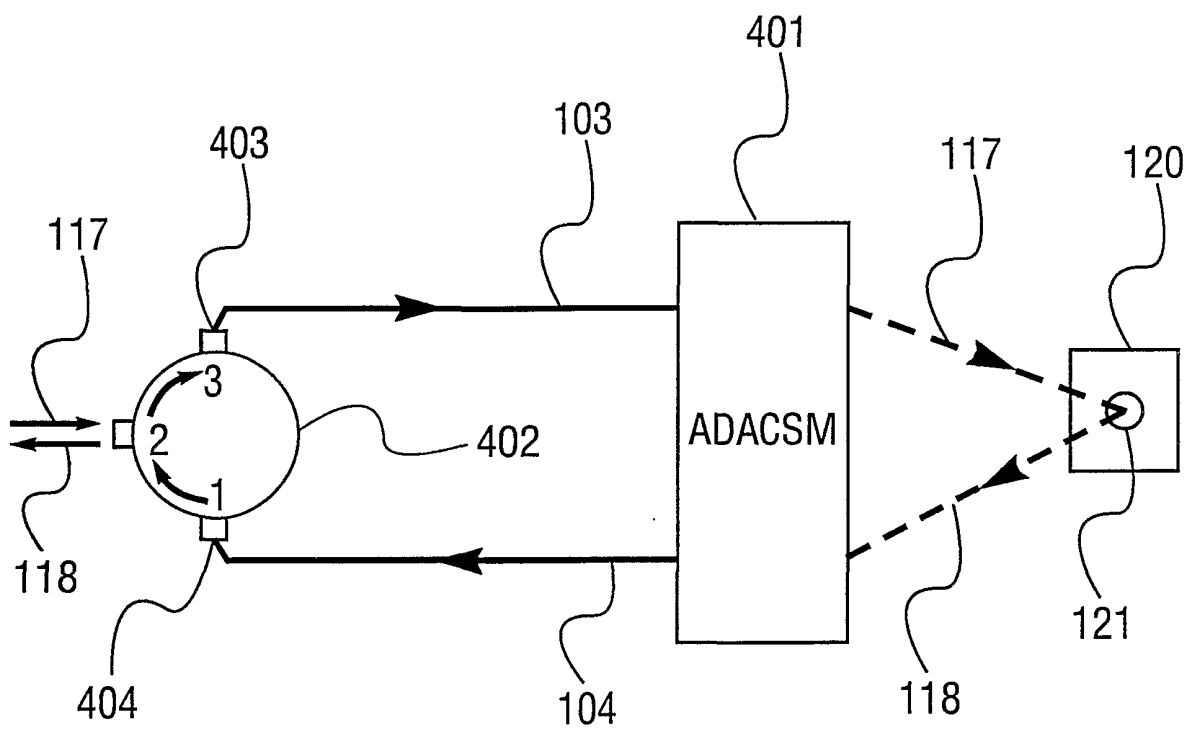

**Fig. 4**

500

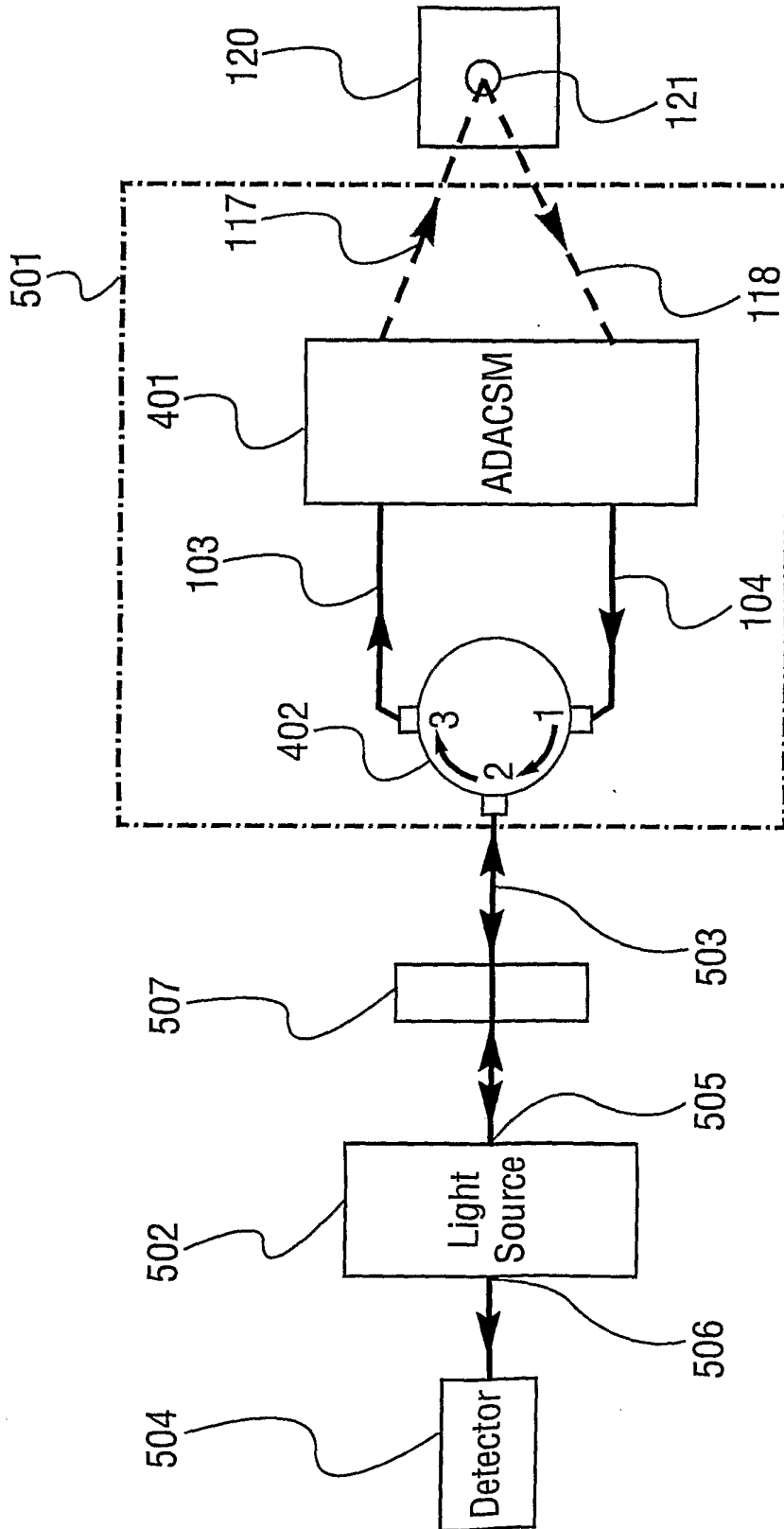

**Fig. 5A**



**550**

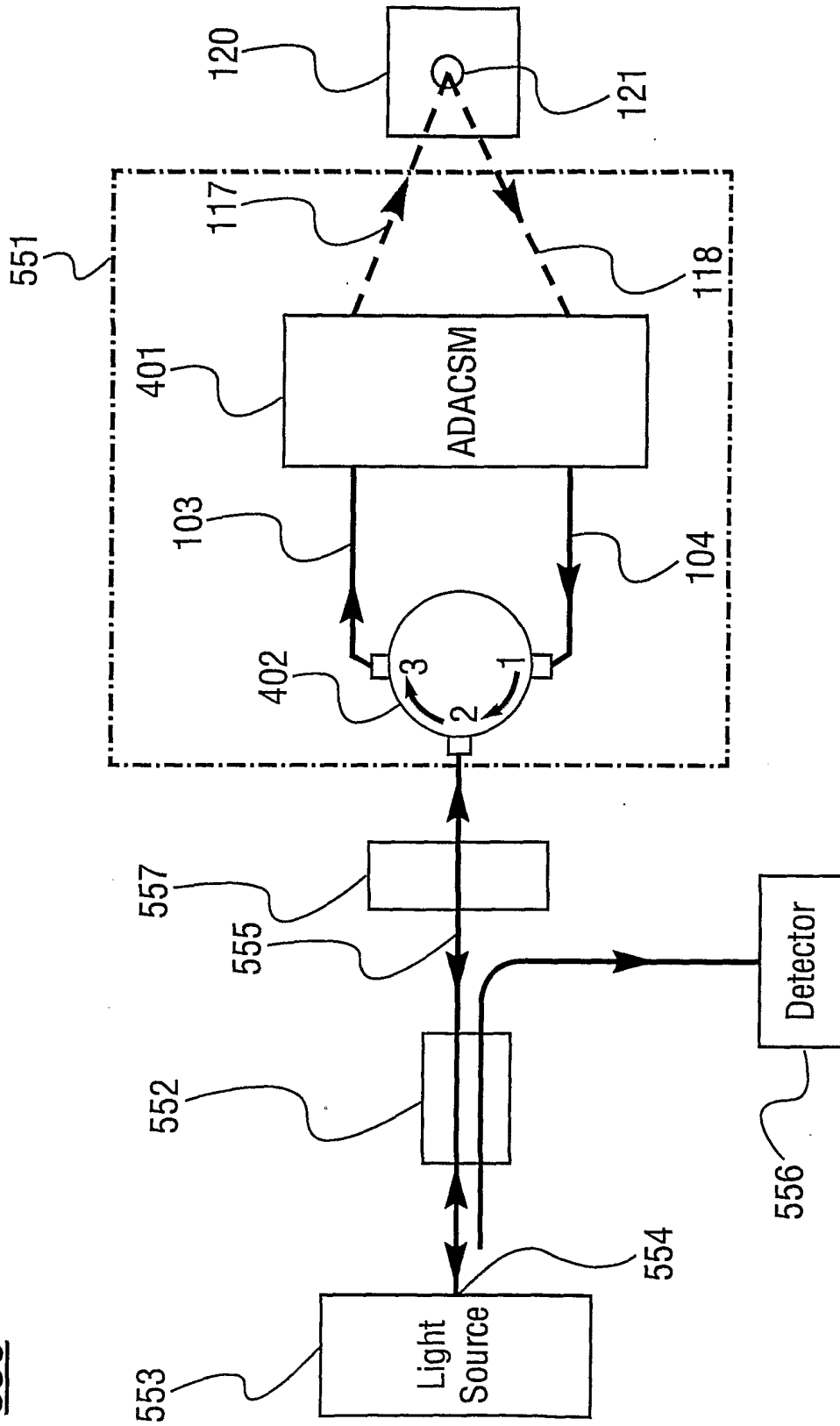

**Fig. 5B**

600

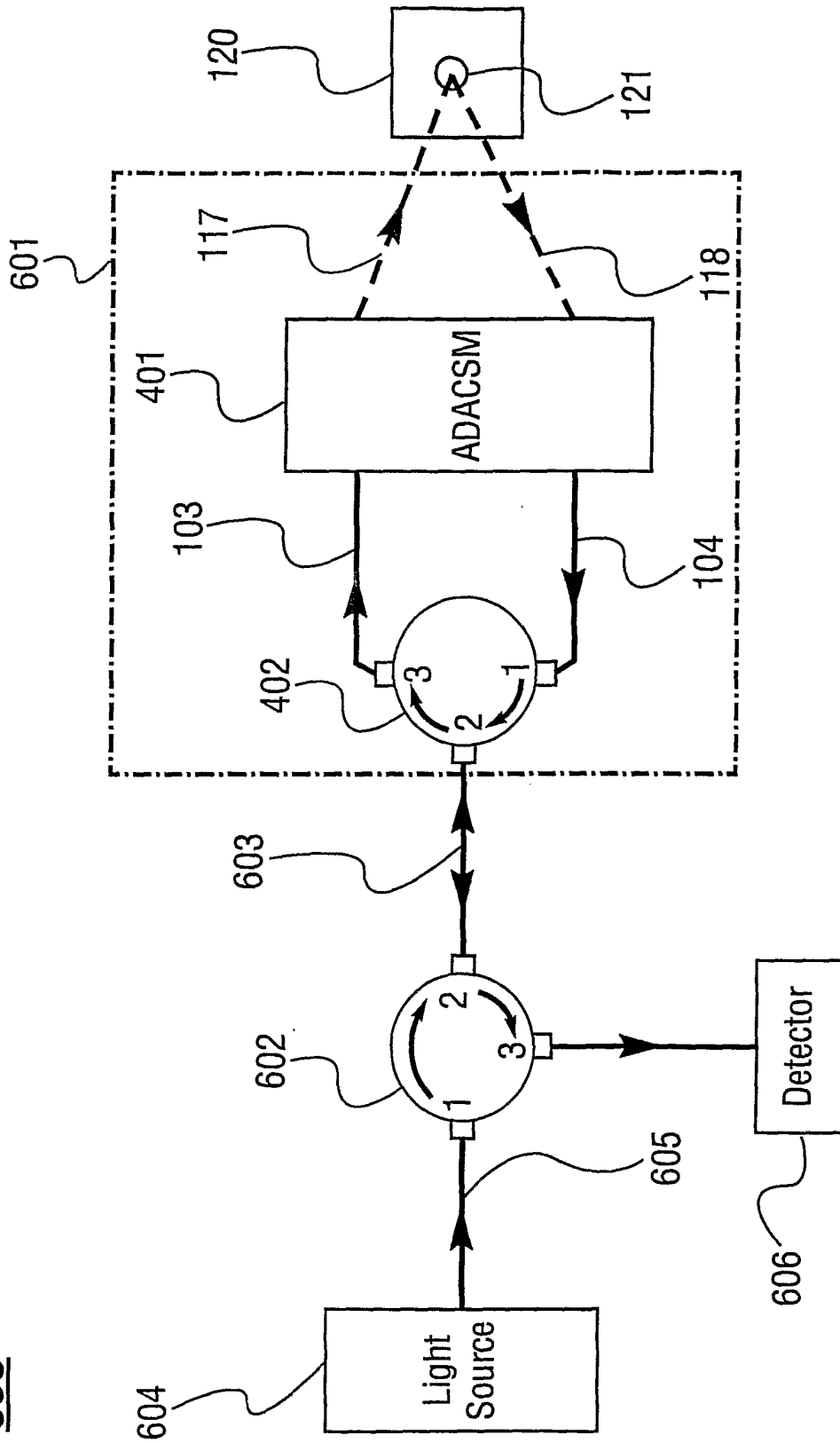

**Fig. 6A**

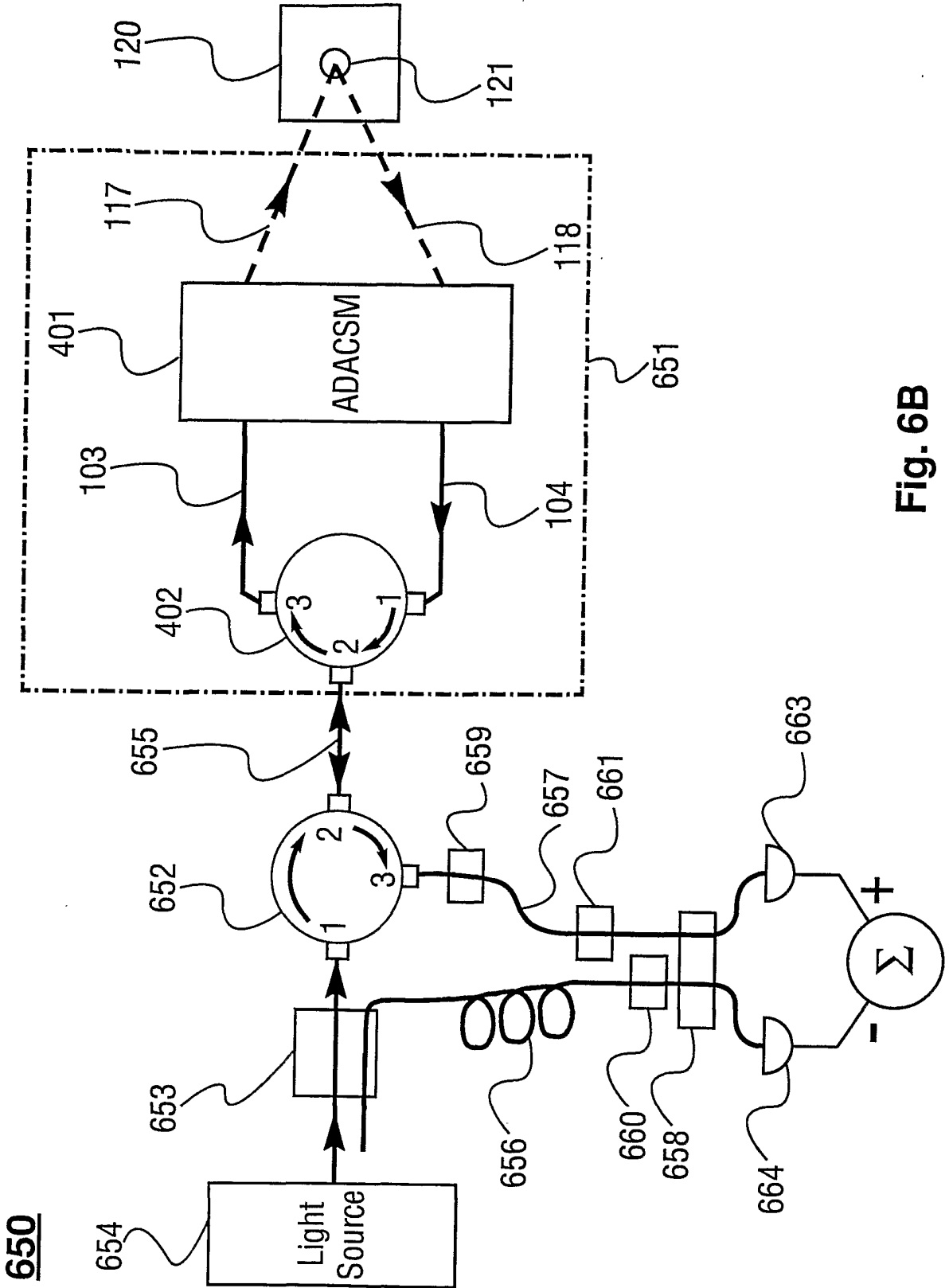

Fig. 6B

650

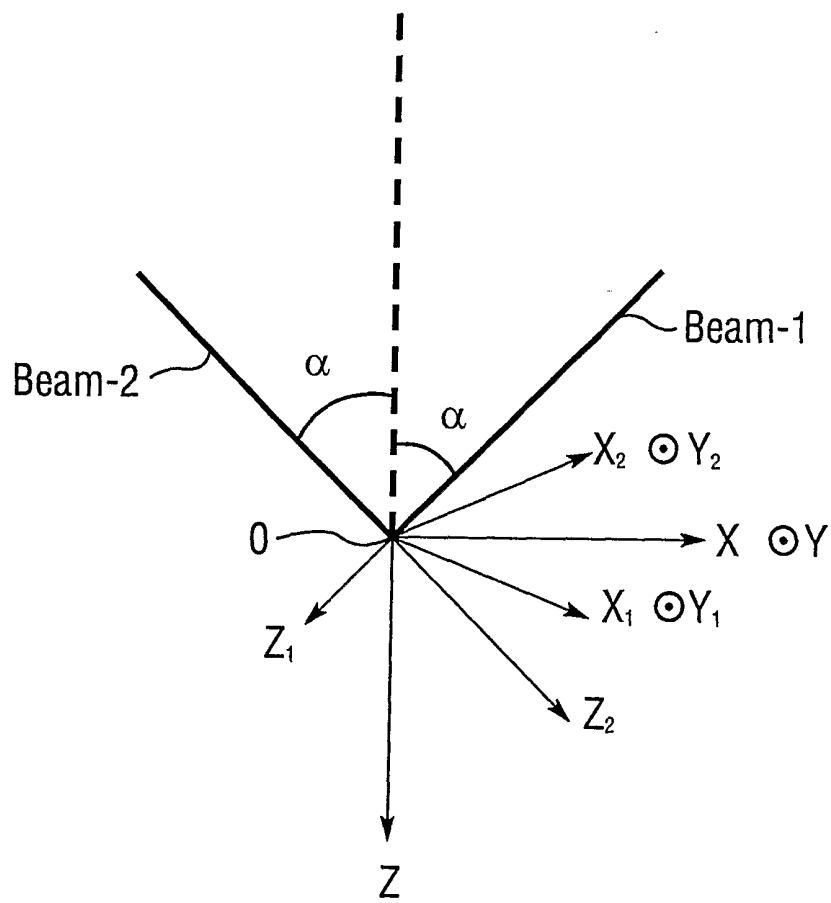

Fig. 7

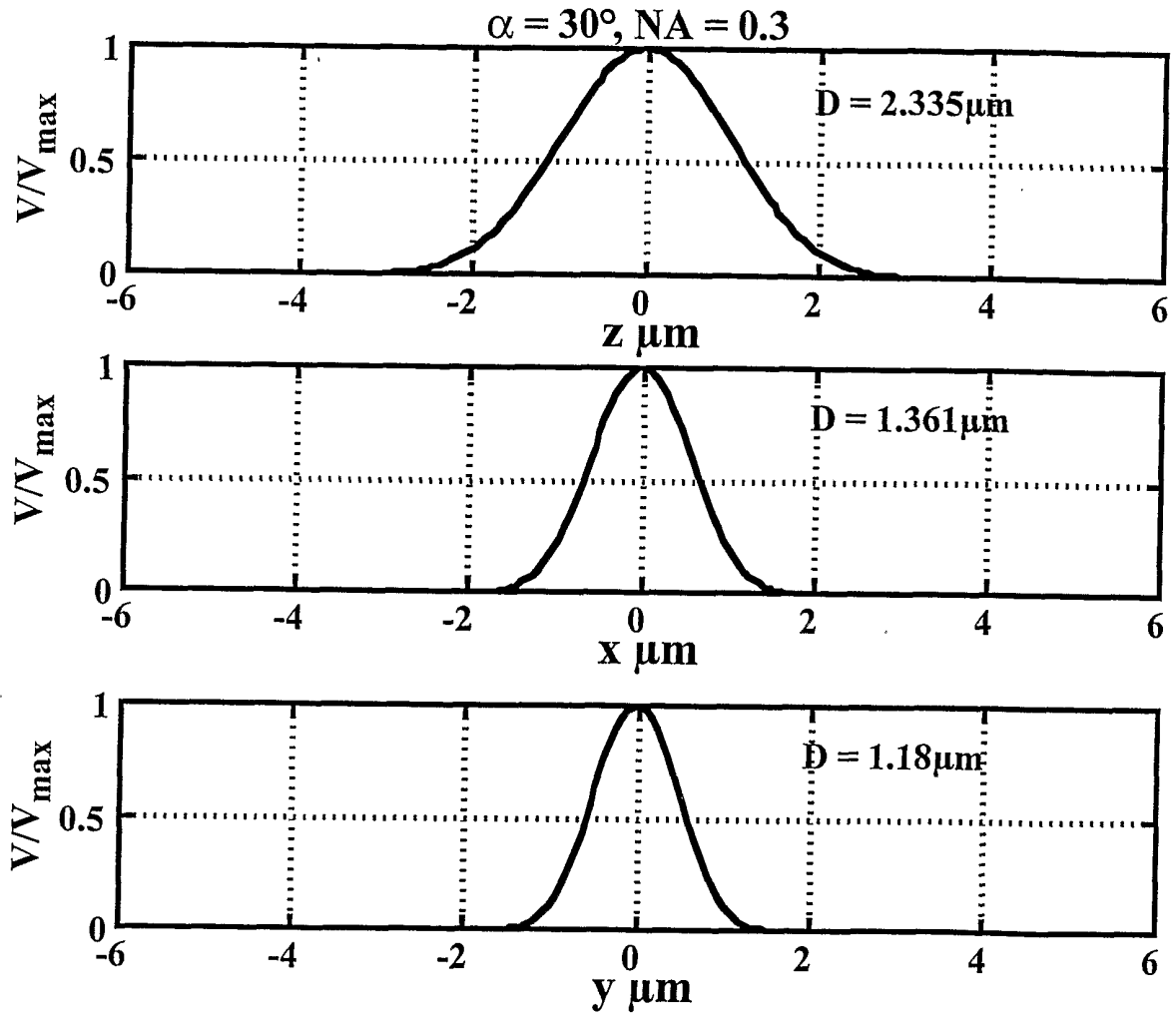
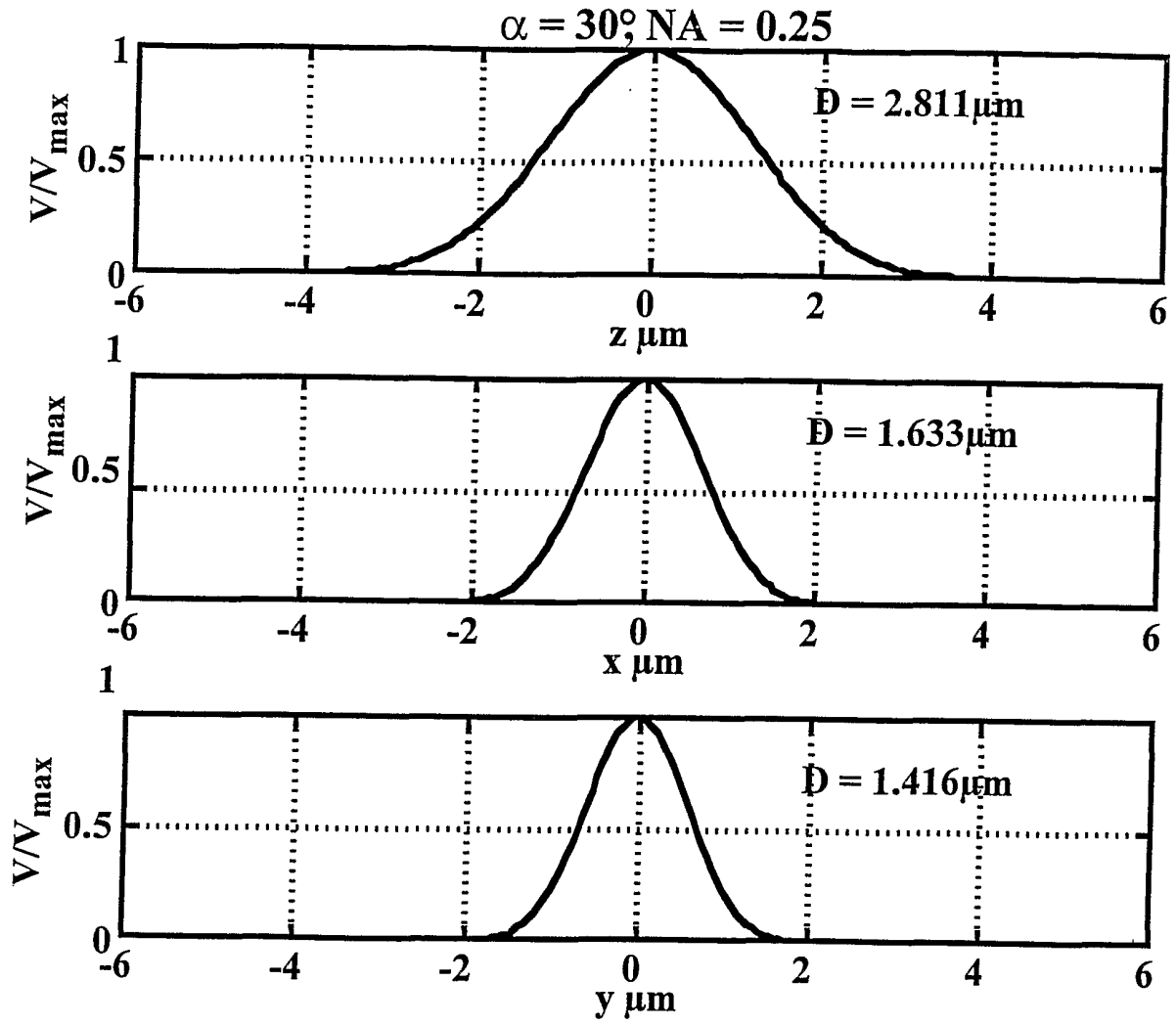

Fig. 8A



**Fig. 8B**

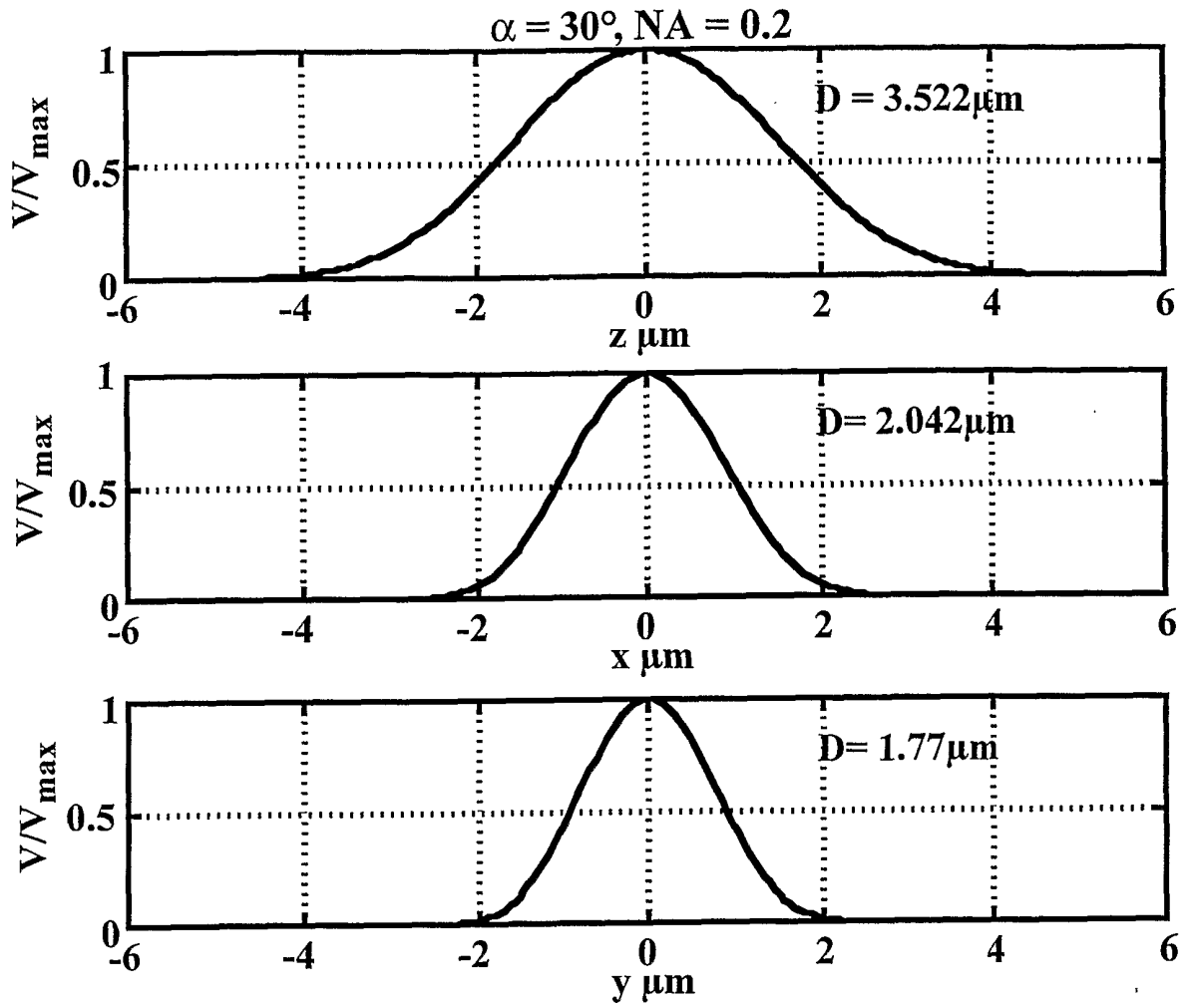

Fig. 8C

INTERNATIONAL SEARCH REPORT

International application No.  
PCT/US01/21029

**A. CLASSIFICATION OF SUBJECT MATTER**

IPC(7) : G02B 27/40, 27/64, 7/04  
US CL : 250/201.3

According to International Patent Classification (IPC) or to both national classification and IPC

**B. FIELDS SEARCHED**

Minimum documentation searched (classification system followed by classification symbols)

U.S. : 250/201.3

Documentation searched other than minimum documentation to the extent that such documents are included in the fields searched  
none

Electronic data base consulted during the international search (name of data base and, where practicable, search terms used)  
East

**C. DOCUMENTS CONSIDERED TO BE RELEVANT**

Category*	Citation of document, with indication, where appropriate, of the relevant passages	Relevant to claim No.
A	US 5,925,874 A (Liege! et al.) 20 July 1999 (20.07.1999), see entire document	1-98

Further documents are listed in the continuation of Box C.  See patent family annex.

* Special categories of cited documents:	"T" later document published after the international filing date or priority date and not in conflict with the application but cited to understand the principle or theory underlying the invention
"A" document defining the general state of the art which is not considered to be of particular relevance	"X" document of particular relevance; the claimed invention cannot be considered novel or cannot be considered to involve an inventive step when the document is taken alone
"E" earlier document published on or after the international filing date	"Y" document of particular relevance; the claimed invention cannot be considered to involve an inventive step when the document is combined with one or more other such documents, such combination being obvious to a person skilled in the art
"L" document which may throw doubts on priority claim(s) or which is cited to establish the publication date of another citation or other special reason (as specified)	"&" document member of the same patent family
"O" document referring to an oral disclosure, use, exhibition or other means	
"P" document published prior to the international filing date but later than the priority date claimed	

Date of the actual completion of the international search 01 OCTOBER 2001	Date of mailing of the international search report 05 NOV 2001
Name and mailing address of the ISA/US Commissioner of Patents and Trademarks Box PCT Washington, D.C. 20231 Facsimile No. (703) 305-3230	Authorized officer Glen K. [Signature] Telephone No. (703) 605-5298 [Signature]