



US00D629019S

(12) **United States Design Patent**
Major

(10) **Patent No.:** **US D629,019 S**

(45) **Date of Patent:** **** Dec. 14, 2010**

(54) **EXCAVATOR ARM**

(75) Inventor: **Gary Edmund Major**, Cheshire (GB)

(73) Assignee: **J.C. Bamford Excavators Limited**,
Rocester, Uttoxeter (GB)

(**) Term: **14 Years**

(21) Appl. No.: **29/357,800**

(22) Filed: **Mar. 17, 2010**

(30) **Foreign Application Priority Data**

Sep. 17, 2009 (EM) 001612805.0002
Feb. 23, 2010 (EM) 001673385.0006

(51) **LOC (9) Cl.** **15-03**

(52) **U.S. Cl.** **D15/32; D15/28**

(58) **Field of Classification Search** D15/10,
D15/22-26, 28, 29, 32; 414/686, 694, 722,
414/718, 815, 723, 685; 37/341, 407
See application file for complete search history.

(56) **References Cited**

U.S. PATENT DOCUMENTS

3,283,928	A *	11/1966	De Bosredon	414/694
3,313,431	A *	4/1967	Kelly	414/694
4,029,225	A *	6/1977	Wirt	414/694
4,264,264	A *	4/1981	McMillan et al.	414/686
4,576,543	A *	3/1986	Kuchyt et al.	414/722
4,798,511	A *	1/1989	Kaczmarczyk et al.	414/686
5,054,990	A *	10/1991	Schaeff	414/694
5,261,780	A *	11/1993	Perry	414/723
5,531,561	A *	7/1996	Rae et al.	414/686
5,606,809	A *	3/1997	Allen	37/443

5,885,050	A *	3/1999	Kim	414/713
D451,105	S *	11/2001	Masumoto et al.	D15/28
D584,749	S *	1/2009	Smith et al.	D15/28
7,549,242	B2 *	6/2009	Schmeling et al.	37/443
D595,746	S *	7/2009	Iida et al.	D15/32
D610,172	S *	2/2010	Yukino et al.	D15/32
2004/0000077	A1 *	1/2004	Fatemi	37/468
2006/0107557	A1 *	5/2006	Fatemi	37/466
2006/0254096	A1 *	11/2006	Poire	37/468
2007/0031233	A1 *	2/2007	Frey	414/685
2008/0063502	A1 *	3/2008	Nilsson	414/685

* cited by examiner

Primary Examiner—Mark A Goodwin

(74) *Attorney, Agent, or Firm*—Goodman, Allen & Filetti PLLC

(57) **CLAIM**

The ornamental design for excavator arm, as shown and described.

DESCRIPTION

FIG. 1 is a left rear perspective view of an excavator arm embodying my design.

FIG. 2 is a front view thereof.

FIG. 3 is a right front prespective view thereof.

FIG. 4 is a right side elevational view thereof.

FIG. 5 is an enlarged rear view thereof.

FIG. 6 is a left side elevational view thereof; and,

FIG. 7 is a left front prespective view thereof.

The broken line showing the machine and actuators in the drawings forms no part of the claimed design.

1 Claim, 7 Drawing Sheets

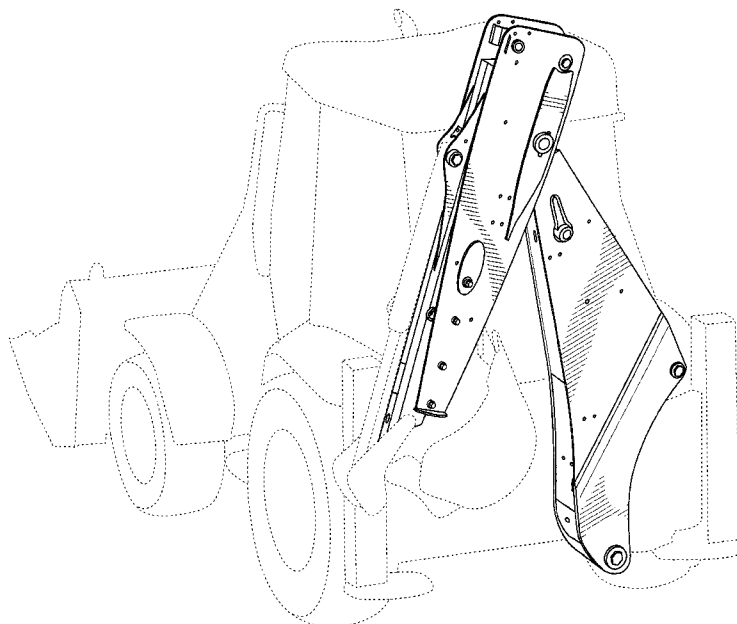

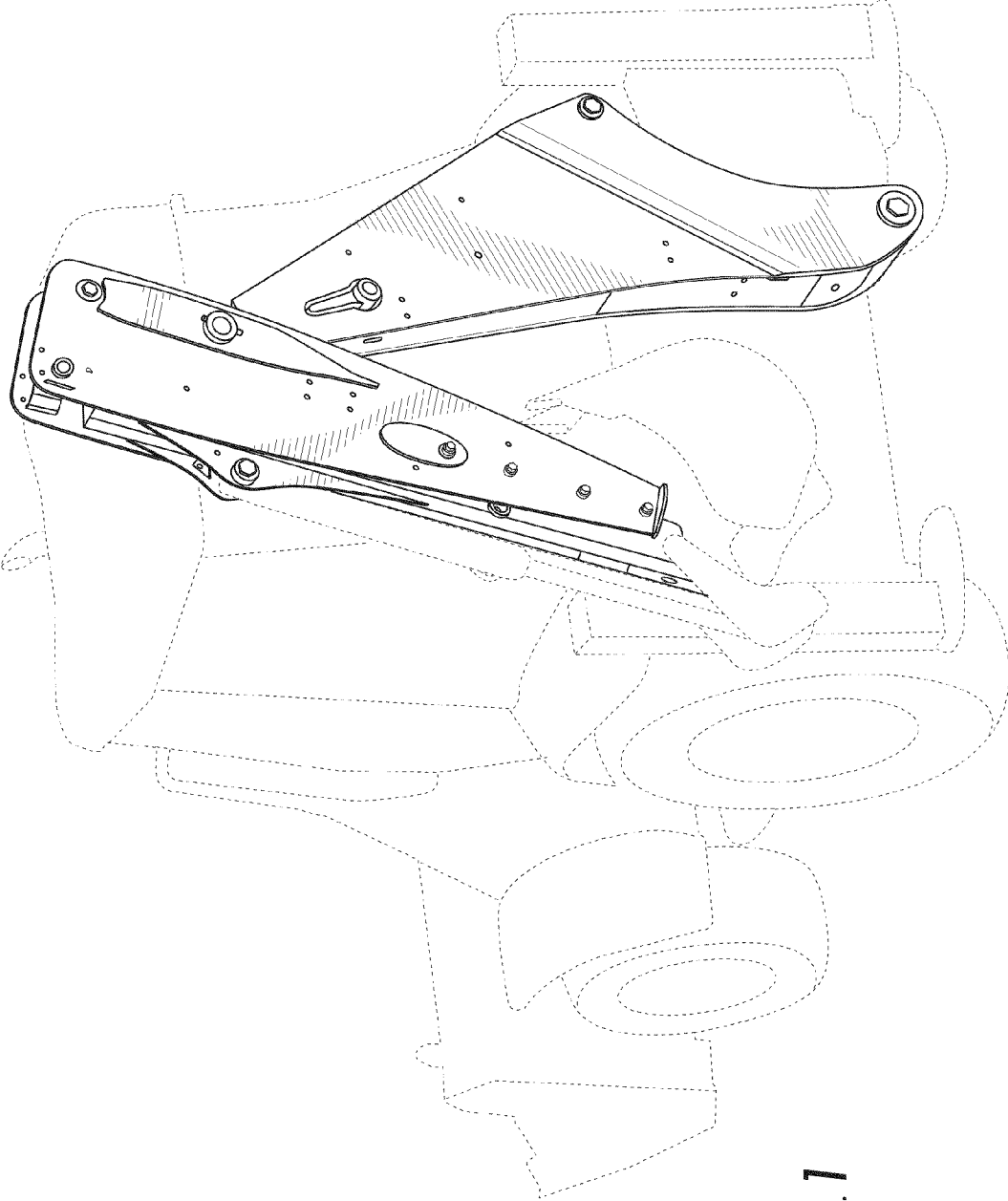

FIG. 7

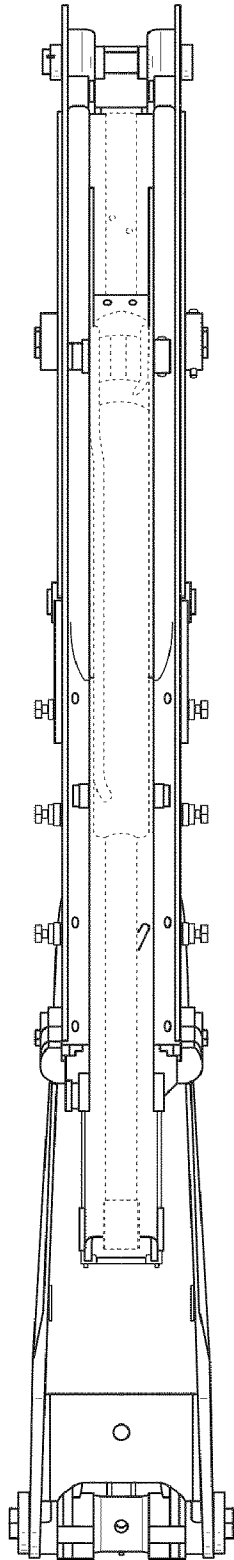

FIG. 2

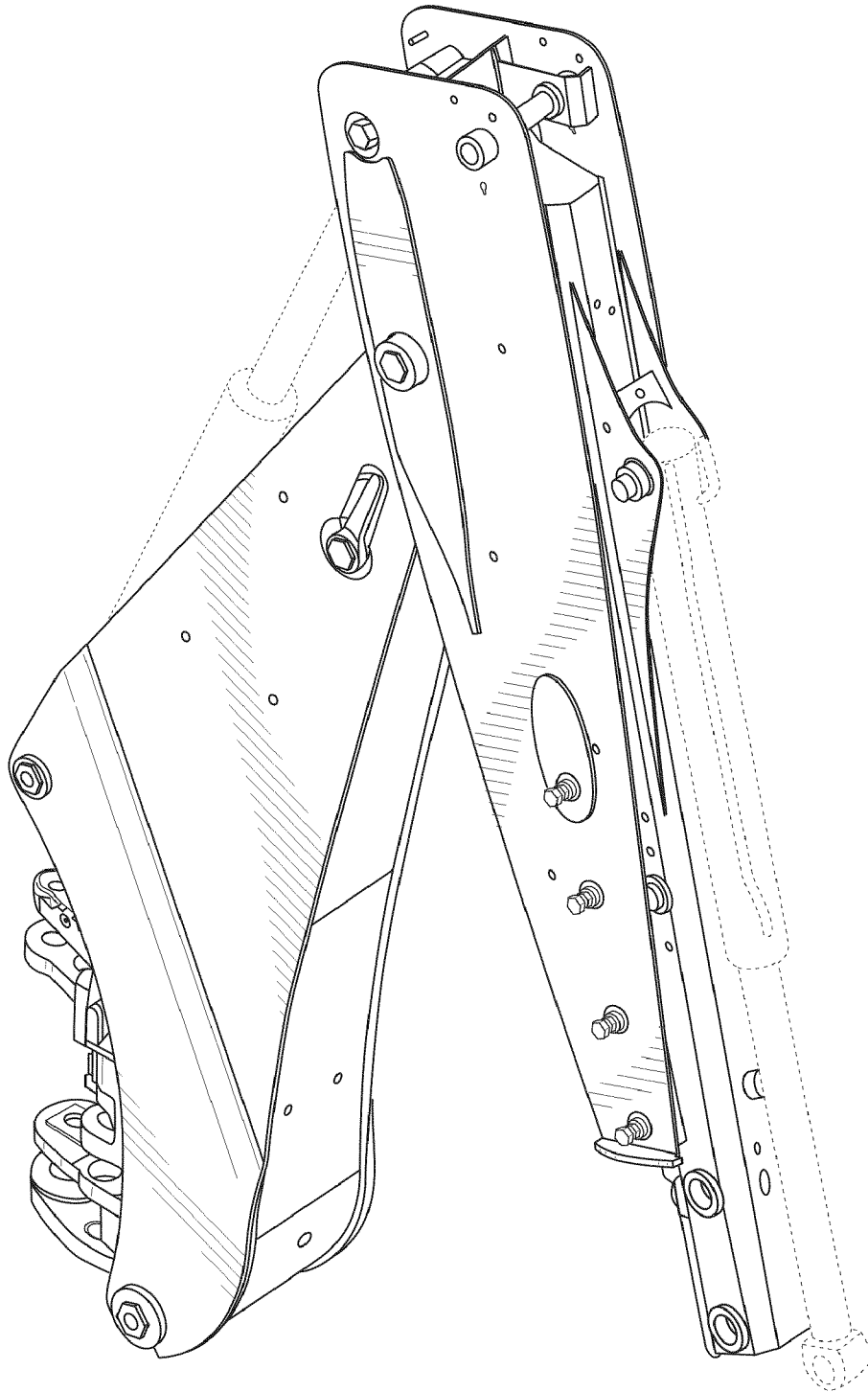

FIG. 3

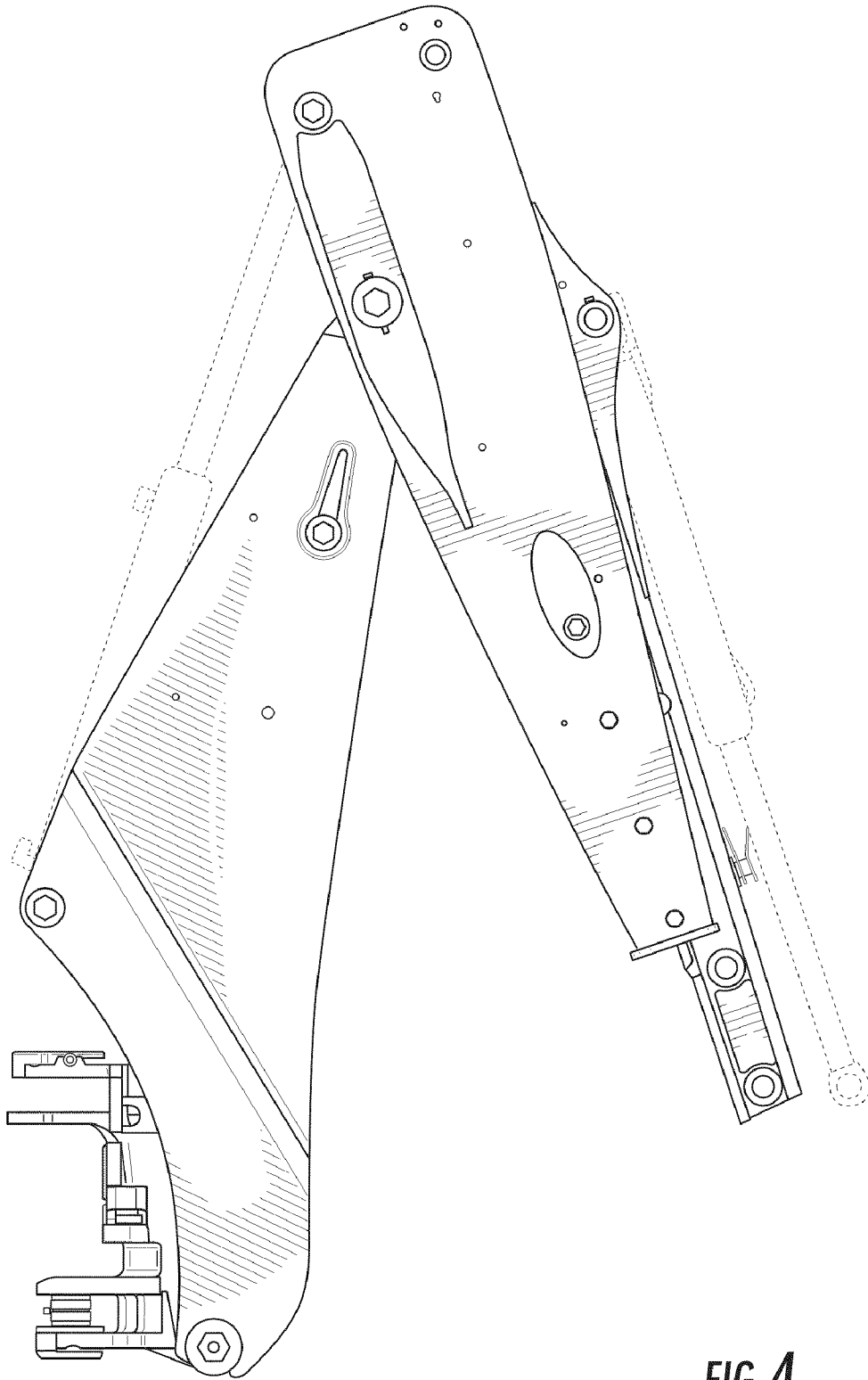

FIG. 4

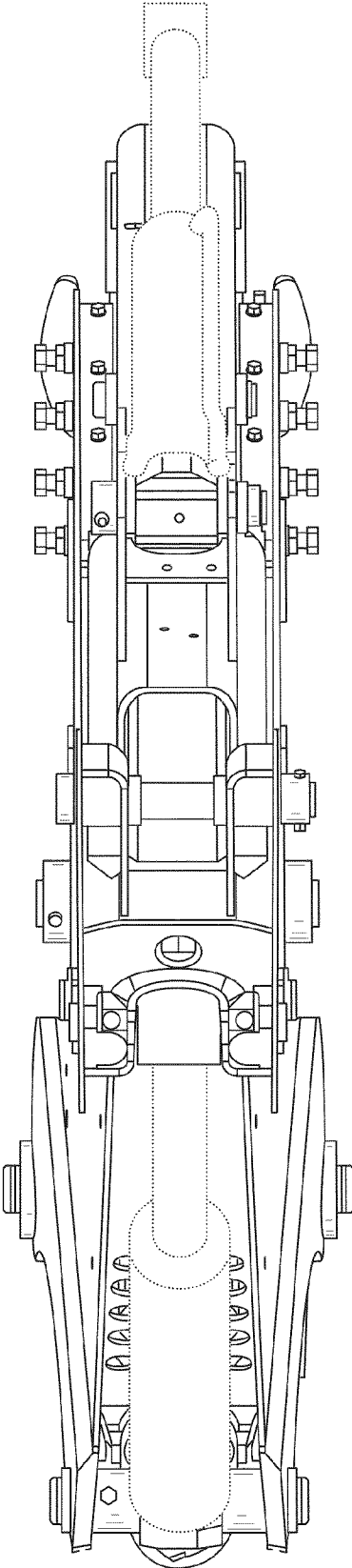

FIG. 5

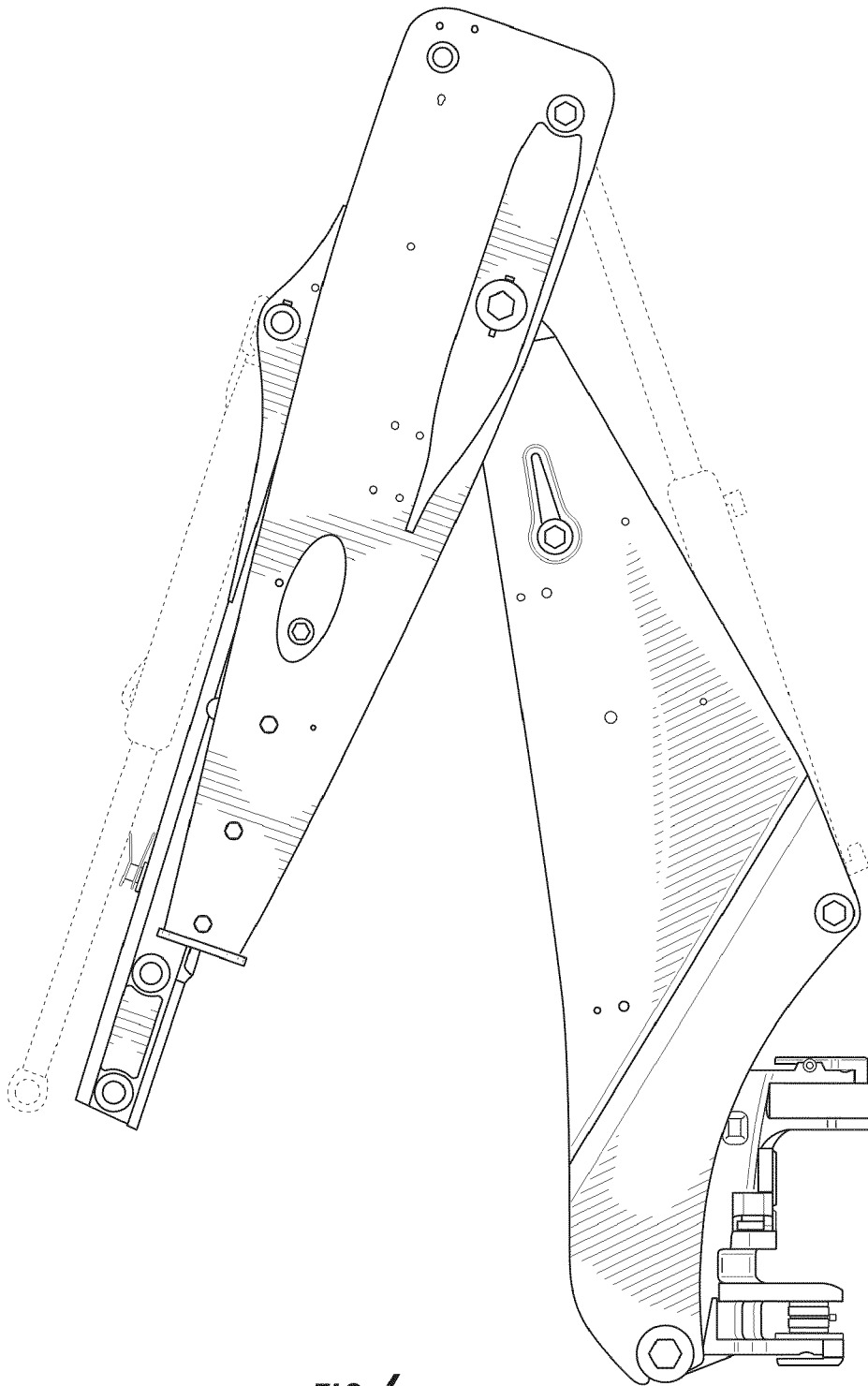

FIG. 6

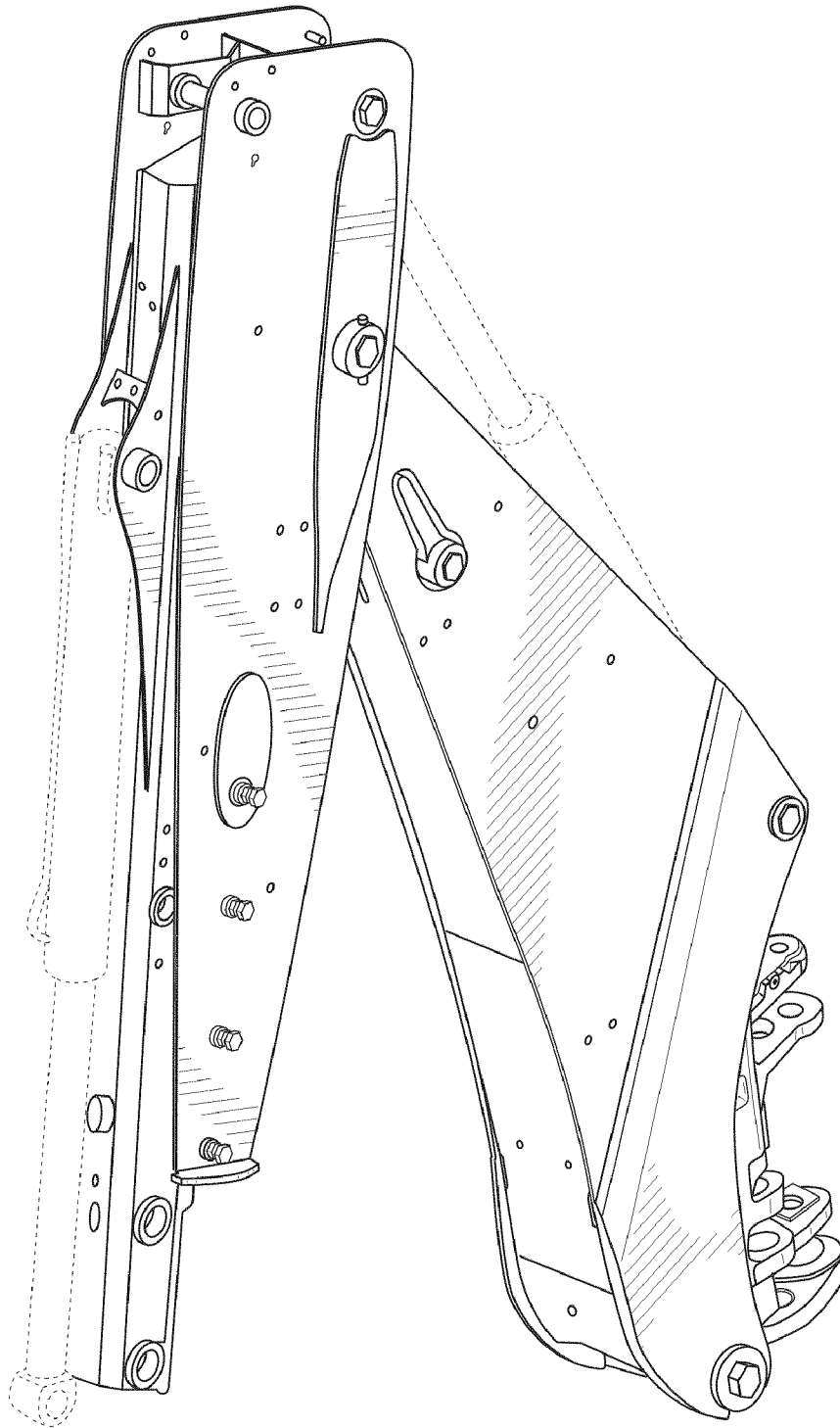

FIG. 7