



(19) **United States**

(12) **Patent Application Publication**
Jennings

(10) **Pub. No.: US 2004/0055982 A1**

(43) **Pub. Date: Mar. 25, 2004**

(54) **PRODUCT DISPLAY SYSTEM**

(76) Inventor: **Charles Jennings**, Bentonville, AR
(US)

Correspondence Address:
HOVEY WILLIAMS LLP
2405 GRAND BLVD., SUITE 400
KANSAS CITY, MO 64108 (US)

(21) Appl. No.: **10/600,308**

(22) Filed: **Jun. 20, 2003**

Related U.S. Application Data

(60) Provisional application No. 60/390,771, filed on Jun. 21, 2002.

Publication Classification

(51) **Int. Cl.⁷** **A47F 3/14**

(52) **U.S. Cl.** **211/126.2; 211/133.4**

(57) **ABSTRACT**

A product display system (10) constructed in accordance with the principles of a preferred embodiment of the present

invention and configured for displaying products above a conventional clothing rack (R) is disclosed. The inventive display system (10) broadly includes a base assembly (12) for supporting the other system components above the rack (R), a plurality of product display trays (14-28) supported on the base assembly (12) for displaying the products (P), and a sign assembly (30) supported on the base assembly (12) for displaying product information and advertising indicia. The inventive display system (10) enables cross-merchandising at the point of sale by utilizing previously unusable space above the conventional circular rack (R) while still complying with display requirements of most mass marketing retail stores. In the preferred embodiment, the base assembly (12) is formed of modular truss sections (32-46) that interconnect to form a sloped tray-supporting surface (12a) that extends radially beyond the perimeter of the rack (R) to place the products (P) supported thereon at an optimum position for viewing and access by the consumer. The preferred display trays (14-28) are uniquely configured to enable them to be arranged in a polygonal arrangement on the base assembly (12) to maximize product storage. The preferred modular base sections (32-46) and display trays (14-28) are complementally configured to enable the trays (14-28) to "nest" in the complemental modular sections (32-46) for easy and convenient shipping, as well as space-efficient storage of the components when not in use.

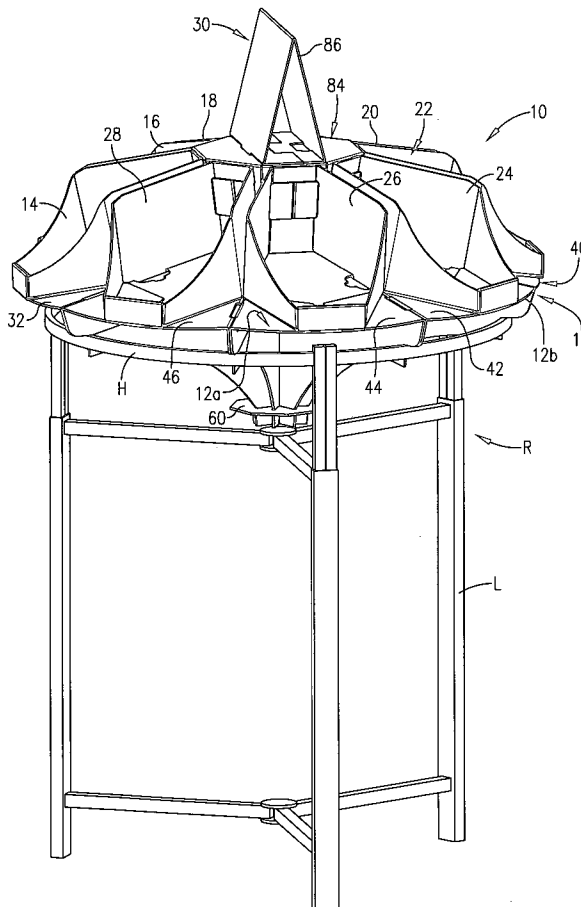

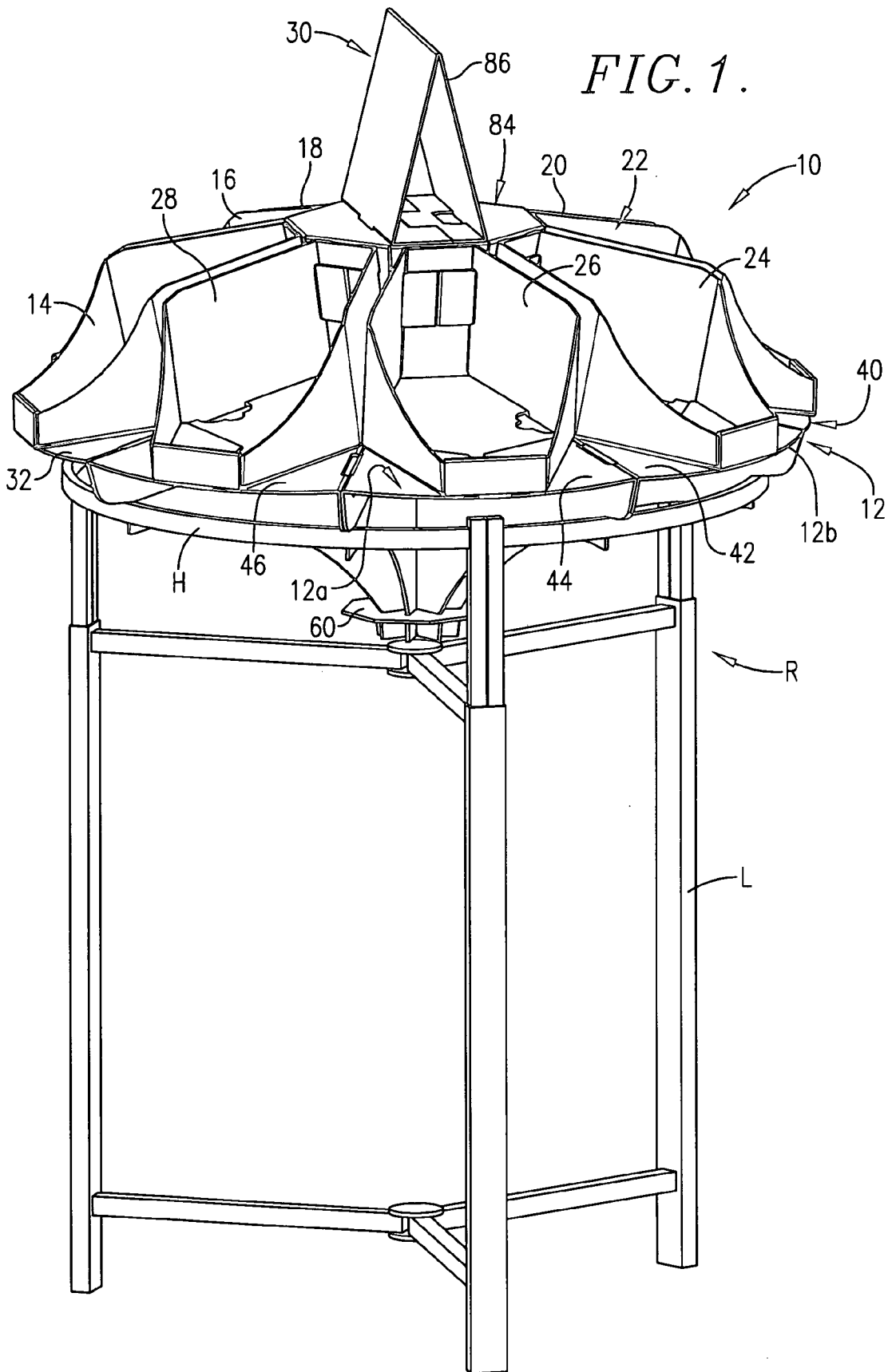

FIG. 2.

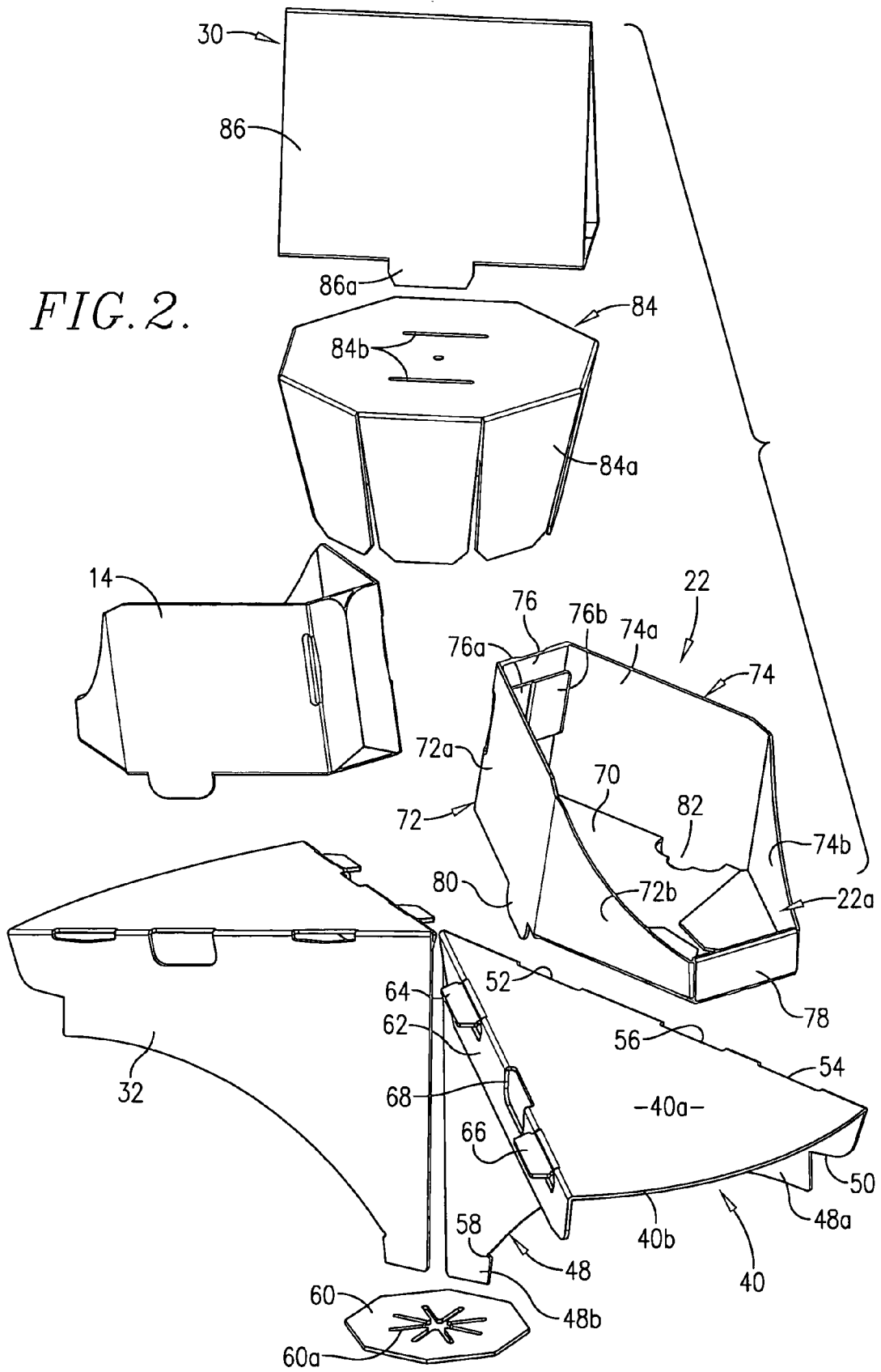
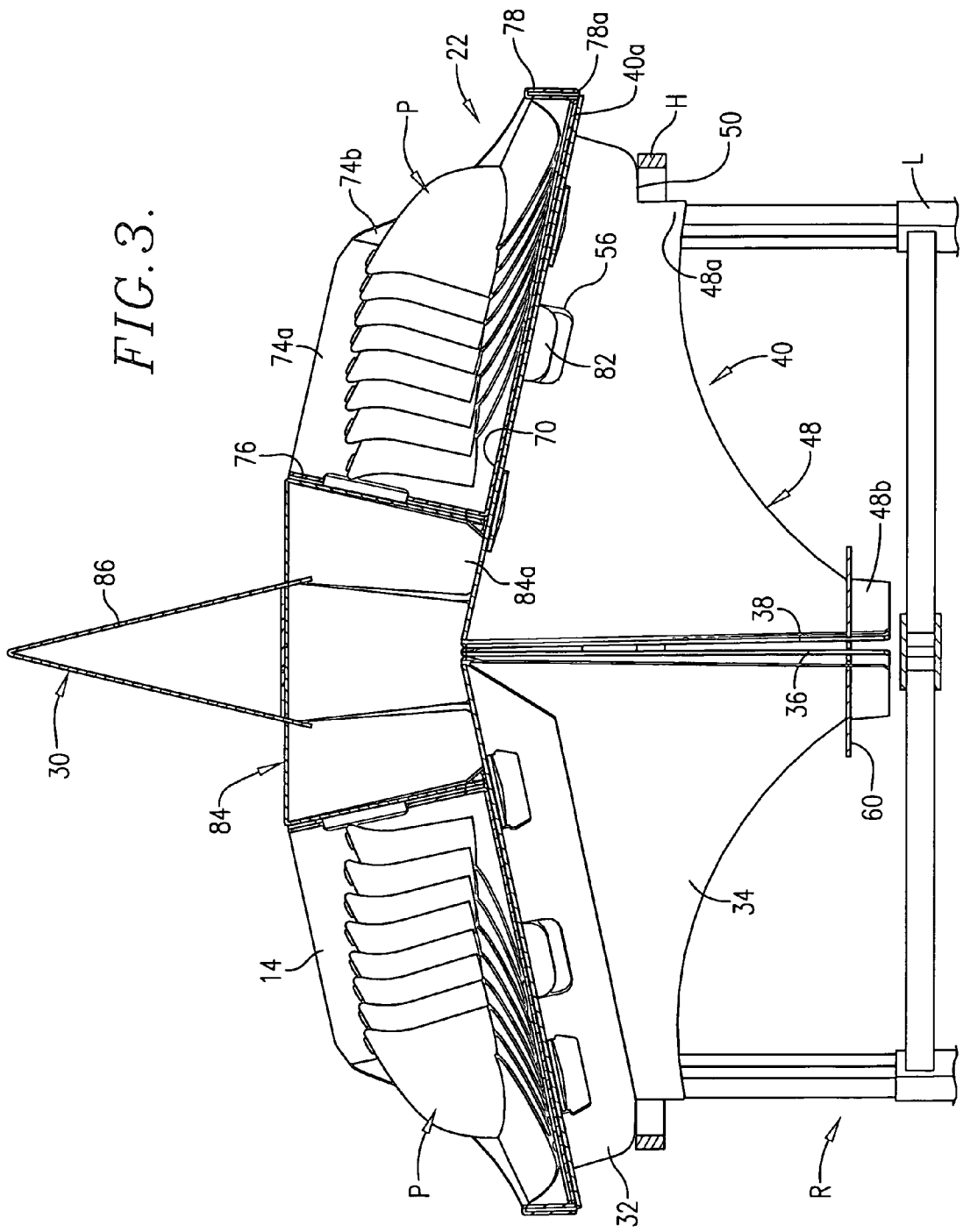
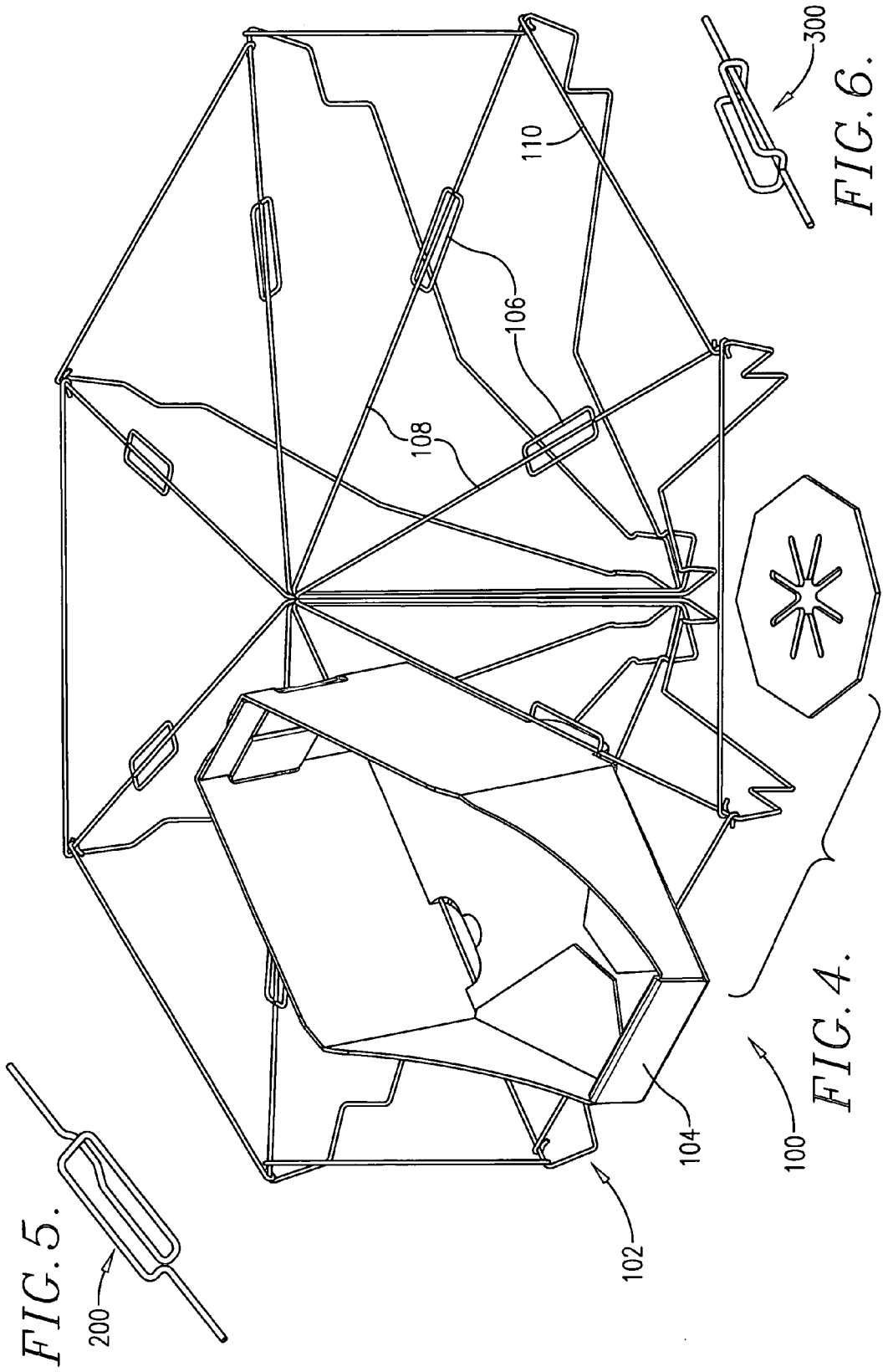

FIG. 3.





PRODUCT DISPLAY SYSTEM

RELATED APPLICATION

[0001] This application claims the benefit of U.S. Provisional Application No. 60/390,771, filed Jun. 21, 2002 and entitled PRODUCT DISPLAY SYSTEM, which is hereby incorporated by reference herein.

BACKGROUND OF THE INVENTION

[0002] 1. Field of the Invention

[0003] The present invention relates generally to systems for displaying products for in-store retail sales. More specifically, the present invention concerns a product display system that includes a base assembly supported above a conventional clothing rack and a plurality of display trays supported on the base assembly for displaying products above the rack in a readily apparent and easily accessible manner. The inventive display system enables cross-merchandising at the point of sale by utilizing previously unusable space above conventional circular racks while still complying with display requirements of most mass marketing retail stores. In a preferred embodiment, the base assembly is formed of modular sections that interconnect to form a sloped tray-supporting surface that extends radially beyond the perimeter of the rack to place the products supported thereon at an optimum position for viewing and access by the consumer. The preferred display trays are uniquely configured to enable them to be arranged in a circular arrangement on the base assembly to maximize product storage. The preferred modular base sections and display trays are complementally configured to enable the trays to "nest" in the modular sections for easy and convenient shipping, as well as space-efficient storage of the components when not in use.

[0004] 2. Discussion of Prior Art

[0005] In many retail clothing and department stores, articles of clothing are frequently displayed on clothing display racks that allow customers to view the articles of clothing while the articles are supported by hangers hung on the racks. For example, such clothing racks are commonly provided in the form of generally circular product display racks having a circular hangrail along the outer perimeter of the rack that is configured to support the hooks of conventional clothing hangers having articles of clothing disposed thereon. In this manner, the clothing-laden hangers can be readily slid along the hangrail to enable the clothing articles thereon to be examined or inspected by a consumer without necessitating removal of the article of clothing from the rack or from the hanger. To enable the clothing-laden hangers to freely slide along the hangrail, the hangrail must present a minimum diameter to provide the requisite clearance between diametrically opposed clothing items (e.g., twenty-four inches, thirty-six inches, forty-eight inches, etc.). Additionally, such clothing racks are generally configured so that the height of the hangrail is configured to suspend the supported clothing items in a position to prevent the clothing from coming into contact with the floor. As a result, typical circular product display racks are frequently configured in height so that the hangrail is at, or somewhat below, eye-level of consumers of average height. Given the practical diametrical and height requirements, the space within and above the hangrail has heretofore been considered generally

unusable for effectively displaying products. Although not as problematic, other non-circular clothing racks for displaying hanger hung clothing items, such as the so called "four-way" rack—i.e., a rack having four transversely extending, generally straight hangrails that define a center square therebetween—also present generally unusable space within and above the hangrails heretofore not optimally utilized for displaying products.

[0006] There are prior art uses for the space within and above the hangrail or rails of conventional clothing racks. The most widely utilized prior art use is displaying signs, for example, a sign supported on a sign holder positioned at or near the center of the hangrail. A typical sign may indicate, for example, that a particular rack contains articles that bear a special feature, such as a particular brand or a discounted price. Such sign holders are clamped onto central support members that support the hangrail. Additionally, some known clothing racks include a substantially flat surface (e.g., a glass or wooden plate) that is supported slightly above the hangrail and is positioned inside the perimeter of the hang rail to support the sign holder or a free standing sign. It is also known to place additional products (e.g., clothing accessories such as socks, shoes, etc.) onto the flat surface in connection with or as an alternative to a sign holder.

[0007] However, these prior art methods of displaying products on a flat surface at or above the hangrail are problematic and suffer from several undesirable limitations. For example, these prior art methods do not optimally present the products for display to the customer and are inconvenient for product organization and inventory control. Products that are displayed in these prior art methods are subject to being moved around on the flat surface adjacent to the hangrail and to falling into the interstitial area between the hangrail and the edge of the flat surface. Moreover, these known display methods do not place the products in a position where they can be easily and readily viewed by a consumer who is standing adjacent the hangrail. That is to say, the products are typically far enough away from the consumer that the consumer must typically reach over the hangrail and pick up one or more of the products off of the flat surface in order to adequately examine the product. Furthermore, these prior art methods are incapable of displaying desired amounts of product above the hangrail and still comply with display requirements of most mass marketing retail stores. For example, many retail stores have height limits on how far products and signage supported on a display rack can extend above the floor. Common limits restrict products to fifty-four inches above the floor and signage to seventy-two inches above the floor. Accordingly, there is a need for a product display system that satisfies the above deficiencies and to provide a convenient way to display products to consumers in a manner that causes consumers to be interested in purchasing the products and to facilitate product stocking.

SUMMARY OF THE INVENTION

[0008] The present invention provides an improved product display system that does not suffer from the problems and limitations of the prior art display methods detailed above. The inventive display system includes a base assembly supported above a conventional clothing rack and a plurality of display trays supported on the base assembly for

displaying products above the rack in a readily apparent and easily accessible manner. In a preferred embodiment, the base assembly is formed of modular sections that interconnect to form a sloped tray-supporting surface that extends radially beyond the perimeter of the rack to place the products supported thereon at an optimum position for viewing and access by the consumer. The preferred display trays include retaining tabs that prevent the trays from sliding off the sloped supporting surface and are uniquely configured to enable them to be arranged in a circular arrangement on the base assembly to maximize product storage. The preferred modular base sections and display trays are complementally configured to enable the trays to "nest" in the modular sections for easy and convenient shipping, as well as space-efficient storage of the components when not in use.

[0009] A first aspect of the present invention concerns a product display apparatus for displaying products above a clothing rack wherein the clothing rack includes a generally circular hangrail for removably supporting clothing hangers by their hooks. The product display apparatus broadly includes a base assembly adapted to be received on the clothing rack and at least one display tray supported on the base assembly and defining an outer-most edge radially spaced from the center of the rack when the base assembly is received on the rack. The base assembly defines an outer-most margin radially spaced from the longitudinal center of the rack when the base assembly is received on the rack. The base assembly includes a tray-supporting surface spaced a hanger dimension above the hangrail when the base assembly is received on the rack wherein the hanger dimension is greater than the height of the hanger hooks so that the hooks can be removed from the hangrail when the base assembly is received on the rack. The display tray is supported on the tray-supporting surface. At least a portion of either the outer-most margin or the outer-most edge extends radially beyond the hangrail when the base assembly is received on the rack.

[0010] A second aspect of the present invention concerns a method of displaying a plurality of first products on the same display with a plurality of second products wherein the first products differ from the second products. The method broadly includes the steps of supporting the first products on a display rack, removably supporting a modular display base on top of the display rack, removably supporting a plurality of display bins on the display base so that at least a portion of each display bin extends over the outer perimeter of the display rack, and supporting the second products in the display bins.

[0011] A third aspect of the present invention concerns a modular product display apparatus broadly including at least one product display tray defining an internal product display bin, and a support platform for supporting the display tray on a product display rack. The display tray includes side-wall panels tapering inwardly toward the rear of the display bin. The display tray includes at least one retaining tab engagingly received in the support platform to thereby retain the display tray in an operative position on a support platform. The support platform includes a plurality of intercommunicating support segments that cooperate to form the support platform and each being adapted to receive the retaining tab.

The support segments are positioned in a substantially circular or polygonal configuration on the product display rack.

[0012] Other aspects and advantages of the present invention will be apparent from the following detailed description of the preferred embodiments and the accompanying drawing figures.

BRIEF DESCRIPTION OF THE DRAWING FIGURES

[0013] Preferred embodiments of the invention are described in detail below with reference to the attached drawing figures, wherein:

[0014] FIG. 1 is a perspective view of a product display apparatus constructed in accordance with a preferred embodiment of the present invention and shown supported above a circular hangrail of a conventional clothing rack;

[0015] FIG. 2 is an exploded assembly view of two of the modular truss sections and the washer element of the base assembly, two of the product display trays, and the sign assembly of the display apparatus illustrated in FIG. 1, with the sign assembly being rotated from its position in FIG. 1 for illustrative purposes only;

[0016] FIG. 3 is a longitudinal sectional view of the display apparatus illustrated in FIGS. 1 and 2 shown supported above the clothing rack (shown in fragmentary) with hats being displayed in the display trays;

[0017] FIG. 4 is a perspective assembly view of a product display apparatus constructed in accordance with a preferred alternative embodiment of the present invention illustrating one of the product display trays supported on the wire base assembly;

[0018] FIG. 5 is a fragmentary perspective view of an alternative tab-receiving slot configuration for the wire base assembly of the display apparatus illustrated in FIG. 4; and

[0019] FIG. 6 is a fragmentary perspective view of a second alternative tab-receiving slot configuration for the wire base assembly of the display apparatus illustrated in FIG. 4.

DETAILED DESCRIPTION OF THE PREFERRED EMBODIMENTS

[0020] FIG. 1 illustrates a product display system 10 constructed in accordance with the principles of a preferred embodiment of the present invention and configured for displaying products above a conventional clothing rack R. The display system 10 is particularly well suited for displaying a plurality of smaller accessory-type products, such as baseball-type hats P as illustrated in FIG. 3. However, the principles of the present invention are not limited to displaying in particular type of product and equally apply to systems configured for displaying virtually any type of consumer product. The display system 10 is illustrated above a standard circular clothing rack R for displaying clothes supported on conventional clothing hangers (not shown), such as plastic or wire hangers having a hanging hook. In one manner well known in the art, the clothing rack R includes a generally circular hangrail H configured to removably and slidably receive the hanger hooks. The hangrail H is supported at the top of the rack R by a plurality

of supporting legs L but the hangrail H is otherwise open at its center. The illustrated hangrail H presents a thirty-six inch diameter and is adjustably supported between forty-two and fifty-four inches above the floor, although various suitable dimensions could be utilized. Although the principles of the present invention are particularly well suited for displaying products above a circular clothing rack, the principles of the present invention are not limited to use with circular clothing racks and equally apply to other types of clothing racks for supporting hanging clothes, including non-circular racks. For example, the display system 10 could be configured to be supported above a standard "four-way" rack having four transversely extending, generally straight hangrails that define a center square therebetween. The illustrated product display system 10 broadly includes a base assembly 12 for supporting the other system components above the rack R, a plurality of product display trays 14, 16, 18, 20, 22, 24, 26, and 28 supported on the base assembly 12 for displaying the products P, and a sign assembly 30 supported on the base assembly 12 for displaying product information and advertising indicia.

[0021] The base assembly 12 is adapted to be removably supported on the clothing rack R and is configured to support the plurality of display trays 14-28 in an optimum operative position above the rack R for displaying products therein in a readily apparent and easily accessible manner. Turning to FIGS. 1-3, the illustrated base assembly 12 is modular in configuration and includes a plurality of modular truss sections 32, 34, 36, 38, 40, 42, 44, and 46 that interconnect to define a tray-supporting surface 12a. In more detail, the tray-supporting surface 12a is preferably generally conical in configuration so that when the display trays 14-28 are supported thereon, the contents of the trays 14-28, such as the products P, are readily viewed by, and easily accessible to a consumer standing adjacent the hangrail H. That is to say, the tray-supporting surface 12a presents a generally circular outermost margin 12b and the surface 12a slopes downwardly generally from the center axis defined by the circular hangrail H towards the outer-most margin 12b. To facilitate easy access to products supported on the base assembly 12, the outer-most margin 12b projects radially beyond the outer perimeter of the hangrail H so that displayed products can be positioned directly above the hangrail H so as to be easily reached by the consumer (see FIG. 3). Furthermore, the tray-supporting surface 12a is sufficiently spaced above the hangrail H to enable hangers supported on the hangrail H to be slid along the hangrail H and removed therefrom and replaced thereon without interferingly engaging the surface 12a. In this regard, the tray-supporting surface 12a is preferably spaced at least about two inches above the hangrail H and more preferably between two and four inches above the hangrail H.

[0022] As indicated above, in the illustrated base assembly 12, the interconnecting modular truss sections 32-46 cooperate to define the tray-supporting surface 12a. Particularly, the illustrated truss sections 32-46 are virtually identically configured and thereby form eight generally equivalent portions of the surface 12a. In this regard, only the truss section 40 will be described in detail with the understanding that the truss sections 32-38 and 42-46 are similarly constructed. Turning to FIGS. 2-3, the truss section 40 presents a generally triangular shaped top surface 40a that forms one-eighth of the tray-supporting surface 12a. The top surface 40a presents an arcuate outer-most margin 40b that

forms one-eighth of the outer-most margin 12b. The truss section 40 includes a support arm 48 extending generally perpendicularly and downwardly from one of the lateral edges of the surface 40a. The support arm 48 includes a lateral arm portion 48a and a longitudinal arm portion 48b. The lateral and longitudinal arm portions 48a, 48b are offset relative to each other by an acute angle. This angle is preferably between about sixty and eighty degrees and more preferably about seventy-five degrees. In this regard, when the longitudinal arm portion 48b is aligned adjacent the longitudinal arm portion of the opposing truss section 32, the acute angle provides the preferred sloped configuration for the top surface 40a (see FIG. 3).

[0023] The lateral arm portion 48a is configured to removably support the truss section 40 on the hangrail H. In this regard, the lateral arm portion 48a includes a rail-receiving notch 50 that engages the hangrail H to thereby support the truss section 40 thereon. For purposes that will subsequently be described, formed between the lateral arm portion 48a and the top surface 40a are a pair of coupling tab-receiving slots 52 and 54 and formed in the arm portion 48a between the slots 52, 54 is a larger retaining tab-receiving slot 56. The longitudinal arm portion 48b is configured to be coupled to the longitudinal arm portions of the other truss sections 32-38 and 42-46 to provide strength and proper positioning for the assembled base assembly 12. Particularly, the longitudinal arm portion 48b includes a washer-receiving groove 58 formed in the inside lower edge of the arm portion 48b. The illustrated base assembly 12 further includes an endless washer element 60 for joining the longitudinal arm portions of the truss sections 32-46 together. The illustrated washer 60 is a disc having eight slits 60a formed therein to receive the longitudinal arm portions. The washer 60 is configured to ride in the washer-receiving grooves, such as the groove 58 in the truss 40. When the longitudinal arm portions of the truss sections 32-46 are joined together by the washer element 60, the longitudinal arm portions are spaced from the rack R, including the hangrail H, so that the base assembly 12 is entirely supported on the rack R by the engagement of the lateral arm portions and hangrail H. In this manner, the base assembly 12 can be quickly and easily placed on top of the conventional clothing rack R and easily removed therefrom.

[0024] The illustrated truss section 40 further includes a side panel 62 extending generally perpendicularly and downwardly from the opposing lateral edge of the surface 40a. Unlike the support arm 48, the side panel 62 does not include a longitudinal arm portion but rather is configured to cooperate with an adjacent support arm to support the base assembly 12 on the hangrail H (see FIG. 1). That is to say, the side panel 62 is sized and dimensioned so that it complements the adjacent rail-receiving notch and cooperates therewith to space the tray-supporting surface 12a a uniform distance from the hangrail H. Formed in the side panel 62 are a pair of coupling tabs 64 and 66 that extend perpendicular to the panel 62 and generally parallel to the top surface 40a (see FIG. 2). The coupling tabs 64, 66 are sized and configured to be received within the coupling tab-receiving slots in the adjacent support arm of the truss section 42 to join the adjacent truss sections 40, 42 together. For purposes that will subsequently be described, formed in the side panel 62 between the tabs 64, 66 is a retaining tab-receiving slot 68 configured similarly to the slot 56 in the support arm 48. The support arm 48 and the side panel 62

further cooperate to enable one or more of the other truss sections 32-38 and 42-46 to be nested within the truss section 40 for convenient storage when the base assembly 12 is not in use. Additionally, as will be further detailed below, one of the display trays 14-28 can also nest within the truss section 40 for compact storage and/or shipping.

[0025] The illustrated truss section 40 is preferably formed from a material that provides sufficient strength and durability to the base assembly 12 yet enables the truss section 40 to be efficiently and cost-effectively manufactured. In this regard, the truss section 40 is preferably formed from a corrugated material, such as paper or plastic, and more preferably from corrugated plastic. For example, in one manner known in the art, the truss section 40 could be formed as a flat blank with suitable fold lines and punch outs formed therein that correspond to the desired assembled configuration. One such suitable blank is disclosed in U.S. Provisional Application No. 60/390,771, which was previously incorporated herein by reference above. However, it is within the ambit of the present invention to form the base assembly 12 from various suitable materials, including more durable materials, such as various metals, to provide the base assembly 12 a more permanent configuration.

[0026] As previously indicated, the truss sections 32-38 and 42-46 are configured virtually identically to the truss section 40 detailed above. The truss sections 32-46 are interconnected, using the coupling tabs and the washer element 60, to form the base assembly 12. However, it is within the ambit of the present invention to utilize various alternative configurations for the base assembly, including, for example, assemblies that are not modular in configuration, or are modular but are joined by methods other than the tabs and washer, or that present a flat supporting surface, etc. However, it is important that the supporting surface presented by the base assembly be supported on top of the clothing rack and configured to support at least a portion of the display tray over the hangrail.

[0027] The product display trays 14-28 are supported on the base assembly 12 for displaying the products P. The illustrated display trays 14-28 are each associated with a corresponding modular truss section 32-46, respectively, and each tray 14-28 is removably supported on the associated truss section 32-46. Each of the display trays 14-28 are virtually identically configured and therefore only the product display tray 22 will be described in detail with the understanding that the display trays 14-20 and 24-28 are similarly constructed. Turning to FIGS. 2-3, the display tray 22 is removably coupled to the truss section 40 and defines an internal storage bin 22a for storing a plurality of the hats P for display. In the illustrated product display tray 22, the storage bin 22a is defined by a bottom wall 70, a pair of oppositely spaced sidewalls 72 and 74, a rear wall 76, and a front wall 78. In more detail, the bottom wall 70 is generally flat and presents a generally hexagonal shape. In addition to the aesthetically pleasing quality of the hexagonal shape, as detailed below, this shape enables the trays 14-28 to be arranged in a polygonal arrangement on the base assembly 12. The sidewalls 72,74 extend upwardly from the bottom wall 70 and each includes a rear panel 72a and 74a, respectively, and a front panel 72b and 74b, respectively. The rear panels 72a,74a follow the hexagonal configuration of the bottom wall 70 and therefore taper inwardly from the front panels 72b,74b to the rear wall 76. In a similar manner,

the front panels 72b,74b taper inwardly from the rear panels 72a,74a to the front wall 78. In this manner, the intersection of the front panels 72b,74b with the rear panels 72a,74a defines the greatest bin width of the internal bin 22a. The front panels 72b,74b are cut away so as to be shorter than the rear panels 72a,74a to provide better viewing of the products P displayed in the bin 22a. Additionally, the hexagonal shape allows product information indicia to be placed on the front panels 72b,74b where it can be viewed by the consumer when the trays 14-28 are arranged in the polygonal arrangement. Such product information indicia could include for example a team name or logo associated with the particular hats P stored in the bin 22a. An example of suitable product information indicia is shown in the U.S. Provisional Application No. 60/390,771 previously incorporated herein by reference.

[0028] The rear wall 76 extends between the rear panels 72a,74a of the sidewalls 72,74 and extends upwardly from the bottom wall 70. The rear wall 76 is sized and configured to fit within the boundary of the triangular top surface 40a of the truss section 40 when the display tray 22 is coupled thereto. Additionally, the rear wall 76 is spaced from the center axis of the hangrail H when the tray 22 is coupled to the truss section 40 to facilitate arranging the trays 14-28 into the polygonal arrangement. As further detailed below, the illustrated tray 22 is preferably formed from a corrugated blank and therefore, in one manner well known in the art, the rear wall 76, when assembled, includes assembly tabs 76a and 76b integrally formed with the sidewalls 72,74 that are inserted into the rear wall 76 to secure the tray 22 in its assembled condition. The front wall 78 is oppositely spaced from the rear wall 76 and extends between the front panels 72b,74b of the sidewalls 72,74 and extends upwardly from the bottom wall 70. The front wall 78 presents a height that is less than the height of the rear wall 76 to facilitate the consumer viewing the products P stored in the bin 22a. In a manner similar to that described above with respect to the rear wall 76, when assembled, the front wall 78 includes assembly tabs (not shown) integrally formed with the sidewalls 72,74 that are inserted into the front wall 78 to secure the tray 22 in its assembled condition.

[0029] In the illustrated display tray 22, the front wall 78 defines the outer-most edge 78a of the display tray 22 when the tray 22 is coupled to the base assembly 12 (see FIG. 3). The outer-most edge 78a is radially spaced from the center axis of the hangrail H when the display tray 22 is coupled to the base assembly 12 on the rack R. The display tray 22 is configured so that at least a portion of the outer-most edge 78a extends radially beyond the hangrail H. In this manner, the products P displayed in the bin 22a are positioned directly above the hangrail H so as to be readily viewed and easily reached by the consumer (see FIG. 3). Although in the illustrated system 10, both the outer-most margin 12b and the outer-most edge 78a extend radially beyond the hangrail H, it is not important that the outer-most margin 12b extend over the hangrail H as long as the display tray 22 can be supported on the tray-supporting surface 12a so that the outer-most edge 78a extends over the hangrail H.

[0030] As indicated above, the display tray 22 is removably coupled to the base assembly 12 and when coupled thereto, is generally prevented from sliding down the sloped tray-supporting surface 12a. In this regard, the illustrated display tray 22 includes a pair of retaining tabs 80 and 82

configured to be received within the tab-receiving slots **68** and **56**, respectively, to removably couple the tray **22** to the truss section **40**. Each of the illustrated retaining tabs **80,82** are integrally formed with the rear panels **72a,74a** and extend perpendicularly below the bottom wall **70**. In this manner, when the display tray **22** is positioned on the truss section **40**, the retaining tabs **80,82** engage the slots **68,56** to prevent the display tray **22** from sliding down the sloped tray-supporting surface **12a**.

[0031] The display tray **22** is sized and configured to nest within the modular truss section **40** to facilitate shipping and/or storage of the associated components **22,40**. For example, the truss section **40** can be assembled and turned upside down and the tray **22** can be assembled, filled with the products P, and placed inside the truss section **40** between the support arm **48** and the side panel **62**. Additionally, the hexagonal configuration of the display tray **22** enables the tray **22** to be nested adjacent three other of the display trays **14-20,24-28** to form a compact presentation for shipping and/or storage. These nesting capabilities cooperate with the removable nature of the display tray **22**, to enable the products P to be shipped prepacked in the bin **22a** and either stored in this display-ready configuration in a space-conserving manner, and/or readily placed on the base assembly **12** to replace a previously depleted display tray.

[0032] The illustrated display tray **22** is preferably formed from a material that facilitates the disposable nature of the replaceable trays that is cost-effective to manufacture yet is sufficiently durable to enable the tray **22** to be shipped and stored with product P prepacked therein. In this regard, the display tray **22** is preferably formed from corrugated paper. For example, in one manner known in the art, the display tray **22** could be formed as a flat blank with suitable fold lines and punch outs formed therein that correspond to the desired assembled configuration. One such suitable blank is disclosed in the U.S. Provisional Application No. 60/390,771 previously incorporated herein by reference above. However, it is within the ambit of the present invention to form the display tray **22** from various suitable materials, including more durable materials, such as corrugated plastic, to enable the display tray **22** to be utilized as a more permanent display bin that is periodically restocked with new products.

[0033] As previously indicated, the product display trays **14-20** and **24-28** are configured virtually identically to the display tray **22** detailed above, and each is associated with a corresponding one of the modular truss sections **32-46**. In this manner, the display trays **14-28** can be arranged in a polygonal configuration around the base assembly **12**. Particularly, the illustrated display trays **14-28** are arranged around the conical tray-supporting surface **12a** so that their rear panels are adjacent each other to form a closed, eight sided figure as shown in FIG. 1. When arranged in this polygonal configuration, the rear walls of the display trays **14-28** are each spaced from the center axis of the hangrail H to form an octagonal open space therebetween. Additionally, when arranged in this polygonal configuration, the outermost edges of the display trays **14-28** are each positioned to extend radially over the hangrail H. A plurality of display trays **14-28** are preferred to facilitate displaying several different types or sizes of a similar product P (e.g., baseball hats having the logos of several different sports teams, etc.). However, it is within the ambit of the present invention to

utilize various alternative configurations for the display trays, including, for example, trays that are variously shaped and configured and that can be arranged in various groups (e.g., six, ten, twelve, etc.) to form virtually any arrangement, or trays that are permanently fixed to the base assembly. However, it is important that the outer-most edge presented by the display tray extend radially at or beyond the outer perimeter of the hangrail H.

[0034] As previously indicated, the sign assembly **30** is supported on the base assembly **12** for displaying product information and advertising indicia. The illustrated sign assembly **30** includes a sign support hub **84** removably supported on the tray-supporting surface **12a** and a sign **86** removably supported on the hub **84**. In more detail, the illustrated sign support hub **84** is generally octagonal in shape and is sized and configured to fit within the interior space defined between the display trays **14-28**. In this regard, the hub **84** includes eight legs **84a** sized to correspond with the rear wall height of the display trays **14-28** so the top surface of the hub **84** is positioned at or above the display trays **14-28** as shown in FIG. 1. The top surface of the hub **84** includes a pair of slits **84b** for removably coupling the sign **86** thereto. The sign **86** is a simple triangular display sign and includes tabs **86a** sized and configured to be received within the slits **84b** for interconnecting the sign **86** onto the top surface of the hub **84**. The sign **86** is operable to display product information and advertising indicia (not shown), such as pricing information, brand information, etc., common to one or more of the products P displayed on the system **10** and/or the clothing products hanging on the rack R. The illustrated sign assembly **30** is preferably formed from a paper or plastic blank. Suitable blanks are disclosed in the U.S. Provisional Application No. 60/390,771 previously incorporated herein by reference above. The sign assembly could be variously alternatively configured and it is within the ambit of the present invention to use the product display system without utilizing a sign.

[0035] The illustrated base assembly **12**, the display trays **14-28**, and the sign assembly **30** are configured to cooperate to comply with standard display limitations and requirements of most mass marketing retail stores. In this regard, the entire product display system **10** is sized and configured to be supported on top of the clothing rack R, adjusted to present the hangrail H at fifty-four inches, and present the upper-most margin of the sign **86** within seventy-two inches of the floor. However, the system **10** could be variously sized and configured to cooperate with a variety of differently sized racks and to satisfy virtually any display requirements and/or limitations.

[0036] In operation, clothing products, such as T-shirts (not shown) are hung on hangers (not shown) that are in turn hung by their hooks onto the hangrail H of the rack R. Next, the modular truss sections **32-46** are assembled and then interconnected by sliding the coupling tabs (e.g., coupling tabs **64,66** of the truss section **40**) into the coupling tab-receiving slots (e.g., slots **52,54** of the truss section **40**) and then encircling the longitudinal arm portions of the support arms (e.g., longitudinal arm portion **48b** of support arm **48**) with the endless washer element **60**. The assembled base assembly **12** is then placed on the rack R so that the assembly **12** is supported on the hangrail H by the lateral arm portions and the side panels (e.g., lateral arm portion

48a and side panel 62). When the base assembly 12 is properly positioned over the rack R, the tray-supporting surface 12a will slope from the center axis to the hangrail H downwardly to the outer-most margin 12b and the outer-most margin 12b will extend radially over the hangrail H.

[0037] Next, the accessory products such as the hats P are packaged into the assembled product display trays 14-28 and the loaded display trays 14-28 are placed on the base assembly 12. Particularly, the retaining tabs (e.g., the tabs 80,82 of the tray 22) are placed into the retaining tab-receiving slots on the truss sections (e.g., the slots 68,56 of the truss section 40) to place each of the display trays 14-28 in the operative position in a polygonal arrangement around the base assembly 12. In the operative position, each of the outer-most edges (e.g., the edge 78a of the tray 22) projects radially beyond the outer perimeter of the hangrail H. The product display trays 14-28 can be nested with each, and/or nested with the modular truss sections 32-46 for shipping and/or storage. Once the products in a product display bin becomes depleted, the display tray can be simply removed from the base assembly 12, discarded, and replaced with a new, prepacked, display tray.

[0038] As indicated above, it is within the ambit of the present invention to utilize various alternative configurations for the product display system, including alternatively configured base assemblies. One such preferred alternative embodiment is the product display system 100 illustrated in FIG. 4. The system 100 is similar in many respects to the previously described system 10 and is likewise configured for placement above a conventional clothing rack, such as the previously described rack R. The system 100 broadly includes a base assembly 102 and a product display tray 104. Although not shown, the system 100, just as with the system 10, includes a plurality of product display trays, each configured and arranged in a manner similar to that described above with respect to the system 10. It will further be appreciated that the system 100 could also include a sign assembly (not shown) similar to the previously detailed sign assembly 30.

[0039] However, unlike the previously described base assembly 12, the base assembly 102 is formed of metal wire to facilitate a more permanent display (e.g., a base assembly that is used over time to support several different product lines in numerous different disposable display trays). The base assembly 102 presents a non-solid tray-supporting surface 102a and a non-circular outer-most margin 102b. The outer-most margin 102b, unlike the margin 12b, does not extend radially beyond the outer perimeter of the hangrail when supported thereon. However, the outer-most edge of the display tray 104 does extend radially beyond the outer perimeter of the hangrail. Unlike the solid tray-supporting surface 12a, the surface 102a is primarily formed by the slotted tab-receiving frames 106. The frames 106 support a portion of the bottom wall of the tray 104 as well as receive the retaining tabs of the tray 104. Although the base assembly 102 is designed to be a more permanent display structure, the illustrated assembly 102 could be modular or permanently interconnected. For example, the assembly includes eight wire truss sections 108 interconnected by eight connecting rods 110. The rods 110 could be removably connected to the truss sections 108 or permanently fixed thereto (e.g., welded, etc.).

[0040] The slotted tab-receiving frames could be variously alternatively configured and suitable preferred alternative embodiments are the frames 200 and 300 illustrated in FIGS. 5 and 6, respectively. The frame 200 is similar in configuration to the frame 106, however, the frame 200 is designed to enable the frame 200 to be formed by bending a single strand of wire, rather than having to fix separate components together. The frame 300 is designed to receive a laterally extending retaining tab. That is to say, the frame 300 is operable to receive a retaining tab that extends parallel to the tray-supporting surface rather than perpendicular thereto. Such a retaining tab could be integrally formed with the display tray or a separate component that slides under the tray to support the tray on the base assembly.

[0041] The preferred forms of the invention described above are to be used as illustration only, and should not be utilized in a limiting sense in interpreting the scope of the present invention. Obvious modifications to the exemplary embodiments, as hereinabove set forth, could be readily made by those skilled in the art without departing from the spirit of the present invention.

[0042] The inventor hereby states his intent to rely on the Doctrine of Equivalents to determine and assess the reasonably fair scope of the present invention as pertains to any apparatus not materially departing from but outside the literal scope of the invention as set forth in the following claims.

What is claimed is:

1. A product display apparatus for displaying products above a clothing rack wherein the clothing rack includes a generally circular hangrail for removably supporting clothing hangers by their hooks, said product display apparatus comprising:

a base assembly adapted to be received on the clothing rack,

said base assembly defining an outer-most margin radially spaced from the longitudinal center of the rack when the base assembly is received on the rack,

said base assembly including a tray-supporting surface spaced a hanger dimension above the hangrail when the base assembly is received on the rack wherein said hanger dimension is greater than the height of the hanger hooks so that the hooks can be removed from the hangrail when the base assembly is received on the rack; and

at least one display tray supported on the tray-supporting surface and defining an outer-most edge radially spaced from the center of the rack when the base assembly is received on the rack,

at least a portion of either said outer-most margin or said outer-most edge extending radially beyond the hangrail when the base assembly is received on the rack.

2. The display apparatus as claimed in claim 1, at least a portion of both of said outer-most margin and said outer-most edge extending radially beyond the hangrail when the base assembly is received on the rack.

3. The display apparatus as claimed in claim 1, said tray-supporting surface presenting said outer-most margin.

4. The display apparatus as claimed in claim 3, said outer-most margin being generally circular in shape.

5. The display apparatus as claimed in claim 3, said tray-supporting surface sloping downwardly from the center thereof toward the outer-most margin.

6. The display apparatus as claimed in claim 1, said base assembly including a plurality of removably interconnected modular truss sections, each of said truss sections forming a portion of said tray-supporting surface.

7. The display apparatus as claimed in claim 6, each of said truss sections including a lateral arm adapted to support the respective truss section on the hangrail when the base assembly is received on the rack and a longitudinal arm suspended within the hangrail when the base assembly is received on the rack.

8. The display apparatus as claimed in claim 7, each of said longitudinal arms being spaced from the rack when the base assembly is received on the rack so that the base assembly is entirely supported on the rack by the engagement of the lateral arms and the hangrail.

9. The display apparatus as claimed in claim 7, said base assembly further including an endless washer element encircling at least a portion of each of the longitudinal arms to thereby interconnect said longitudinal arms.

10. The display apparatus as claimed in claim 6, said plurality of truss sections including eight sections wherein each of the eight sections forms a generally equal portion of said tray-supporting surface.

11. The display apparatus as claimed in claim 1, said display tray being removably supported on the tray supporting surface.

12. The display apparatus as claimed in claim 11, said tray-supporting surface presenting said outer-most margin and sloping downwardly from the center thereof toward the outer-most margin, said display tray including at least one retaining tab removably received through said tray-supporting surface to generally prevent said display tray from sliding down said surface.

13. The display apparatus as claimed in claim 1; and

a plurality of additional display trays supported on the tray-supporting surface and each defining an outer-most edge radially spaced from the center of the rack and extending radially beyond the hangrail when the base assembly is received on the rack.

14. The display apparatus as claimed in claim 13,

each of said first-mentioned and additional display trays defining an inner-most edge adjacent the center of the rack when the base assembly is received on the rack and further defining an intermediate bin section defined between said innermost and outer-most edges and adapted to receive products.

15. The display apparatus as claimed in claim 14,

each of said intermediate bin sections presenting at least one bin width dimension, each of said inner-most edges presenting an inner edge width dimension, and each of said outer-most edges presenting an outer edge width dimension wherein said bin width dimension is greater than both of said inner and outer edge widths dimensions so that each display tray tapers from the intermediate bin section toward the edges.

16. The display apparatus as claimed in claim 13,

said base assembly including a plurality of removably interconnected modular truss sections wherein each of

said truss sections forms a generally equal portion of said tray-supporting surface,

each of said truss sections being associated with a corresponding one of said display trays.

17. The display apparatus as claimed in claim 16,

each of said display trays including at least one retaining tab extending through the equal portion of said tray-supporting surface formed by the corresponding truss section.

18. The display apparatus as claimed in claim 16,

each of said equal portions of said tray-supporting surface being generally triangular in configuration,

each of said truss sections including a pair of side walls that extend downwardly from said equal portion of said tray-supporting surface.

19. The display apparatus as claimed in claim 18,

each of said display trays being configured to fit within the side walls of the corresponding truss section.

20. The display apparatus as claimed in claim 14; and

a sign supported on the tray-supporting surface between the inner-most edges of said display trays,

said sign extending above said display trays.

21. The display apparatus as claimed in claim 1,

said display tray including a rear-wall panel having a rear-wall height and a rear-wall width and front-wall panel having a front-wall height and a front-wall width wherein the front-wall height is smaller than the rear-wall height and the front-wall width is at least as wide as the rear-wall width.

22. The display apparatus as claimed in claim 21,

said display tray further including a pair of spaced side-wall panels that define an internal storage bin adapted to store products.

23. The display apparatus as claimed in claim 22,

said side-wall panels tapering inwardly generally from the middle toward the rear-wall to define a tapered rear section and tapering inwardly generally from the middle toward the front-wall to define a tapered front section.

24. The display apparatus as claimed in claim 23,

said side-wall panels each including at least one retaining tab removably retaining the display tray in an operative position on the tray-supporting surface.

25. The display apparatus as claimed in claim 24; and

a plurality of additional display trays each being configured similarly to the first-mentioned display tray wherein the tapered rear sections of the display trays are positioned adjacent one another to form a generally polygonal arrangement.

26. The display apparatus as claimed in claim 1,

said base assembly being formed of a corrugated material.

27. The display apparatus as claimed in claim 26,

said corrugated material being paper.

28. The display apparatus as claimed in claim 1,

said base assembly being formed substantially of wire.

29. A method of displaying a plurality of first products on the same display with a plurality of second products wherein

the first products differ from the second products, said method comprising the steps of:

- (a) supporting the first products on a display rack;
- (b) removably supporting a modular display base on top of the display rack;
- (c) removably supporting a plurality of display bins on the display base so that at least a portion of each display bin extends over the outer perimeter of the display rack; and
- (d) supporting the second products in the display bins.

30. The method as claimed in claim 29,

step (a) including the steps of supporting the first products on hangers and supporting the hangers on the display rack.

31. The method as claimed in claim 30,

said display rack including a generally circular hangrail, said hangers being slidably received on said hangrail.

32. The method as claimed in claim 31,

said at least a portion of each display bin comprising an outer-most edge thereof radially spaced from the center axis of the circular hangrail when said display bins are supported on the display base,

said outer-most edges extending radially beyond the hangrail,

step (b) including the step of supporting the display base on the hangrail and spacing at least a predominate portion of the display base from said hangrail to permit the hangers to be slidably received on the hangrail under said predominate portion of said display base.

33. The method as claimed in claim 29,

step (b) including the steps of removably interconnecting a plurality of modular truss sections to form said display base and arranging the truss sections so that each section forms a generally equivalent portion of a generally circular bin-supporting surface at the top of said display base.

34. The method as claimed in claim 33,

said bin-supporting surface defining an outer-most margin that extends radially beyond the outer perimeter of the display rack.

35. The method as claimed in claim 34,

said bin-supporting surface sloping downwardly from the center axis thereof toward the outer-most margin,

step (c) including the steps of forming at least one retaining tab in each of the display bends and placing the retaining tabs through the bin-supporting surface to prevent the display bins from sliding down the bin-supporting surface.

36. The method as claimed in claim 33,

step (b) including the step of forming the modular truss sections out of corrugated paper.

37. The method as claimed in claim 29,

step (c) including the steps of forming at least six display bins wherein each of the bins presents a generally hexagonal horizontal cross sectional shape and arrang-

ing the display bins adjacent one another on the display base in a generally polygonal arrangement.

38. A modular product display apparatus comprising:

at least one product display tray defining an internal product display bin,

said display tray including side-wall panels tapering inwardly toward the rear of the display bin; and

a support platform for supporting the display tray on a product display rack,

said display tray including at least one retaining tab engagingly received in the support platform to thereby retain the display tray in an operative position on a support platform,

said support platform including a plurality of intercommunicating support segments that cooperate to form the support platform and each being adapted to receive the retaining tab,

said support segments being positioned in a substantially circular or polygonal configuration on the product display rack.

39. The display apparatus as claimed in claim 38,

said support platform including eight of the support segments.

40. The display apparatus as claimed in claim 38,

said support platform further including a retaining washer engagingly received on the support segments to thereby retain the support segments in their substantially circular or polygonal configuration.

41. The display apparatus as claimed in claim 38,

said support platform defining a tray-supporting surface,

said tray-supporting surface presenting a substantially outwardly downward slope towards an outer perimeter of the product display rack.

42. The display apparatus as claimed in claim 38,

said display tray further including a rear-wall panel presenting a rear-wall height and a rear-wall width and a front-wall panel presenting a front-wall height and a front-wall width wherein the front-wall height is smaller than the rear-wall height and the front-wall width is at least as wide as the rear-wall width.

43. The display apparatus as claimed in claim 38; and

an information display unit adapted to display indicia on at least one side thereof.

44. The display apparatus as claimed in claim 43,

said support platform further including a central portion, said information display unit being supported on said central portion.

45. The display apparatus as claimed in claim 44,

said central portion of said support platform being generally conical in shape.

46. The display apparatus as claimed in claim 45,

said product display rack comprising a substantially cylindrical clothes hanging rack for supporting hanging clothes,

said rack including an upper circular clothes hanger support structure and at least two legs extending laterally from said hanger support structure,

said support segments being supported on said hanger support structure.

47. The display apparatus as claimed in claim 43,

said indicia on the information display unit including product information indicia.

48. The display apparatus as claimed in claim 43,

said indicia on the information display unit including advertising indicia.

49. The display apparatus as claimed in claim 38,

said internal display bin presenting a tapered rear section defined between the tapering side-wall panels and the rear of the bin.

50. The display apparatus as claimed in claim 49; and

a plurality of additional product display trays each being similarly configured to the at least one product display tray,

the tapered rear sections of the product display trays being positioned adjacent one another to present a generally circular or polygonal arrangement.

51. The display apparatus as claimed in claim 38,

at least one of said support segments including a tab-receiving support slot,

said display tray including a bottom panel,

said retaining tab being substantially coplanar with one of the side-wall panels and non-coplanar with the bottom panel and extending there below to be engagingly received in said support slot.

52. The display apparatus as claimed in claim 38,

said support segments being formed from corrugated paper.

53. The display apparatus as claimed in claim 38,

said support segments being substantially formed of wire.

* * * * *