

No. 884,830.

PATENTED APR. 14, 1908.

J. T. LINDAHL.
CENTRIFUGAL SLIME SEPARATOR.
APPLICATION FILED JUNE 20, 1906.

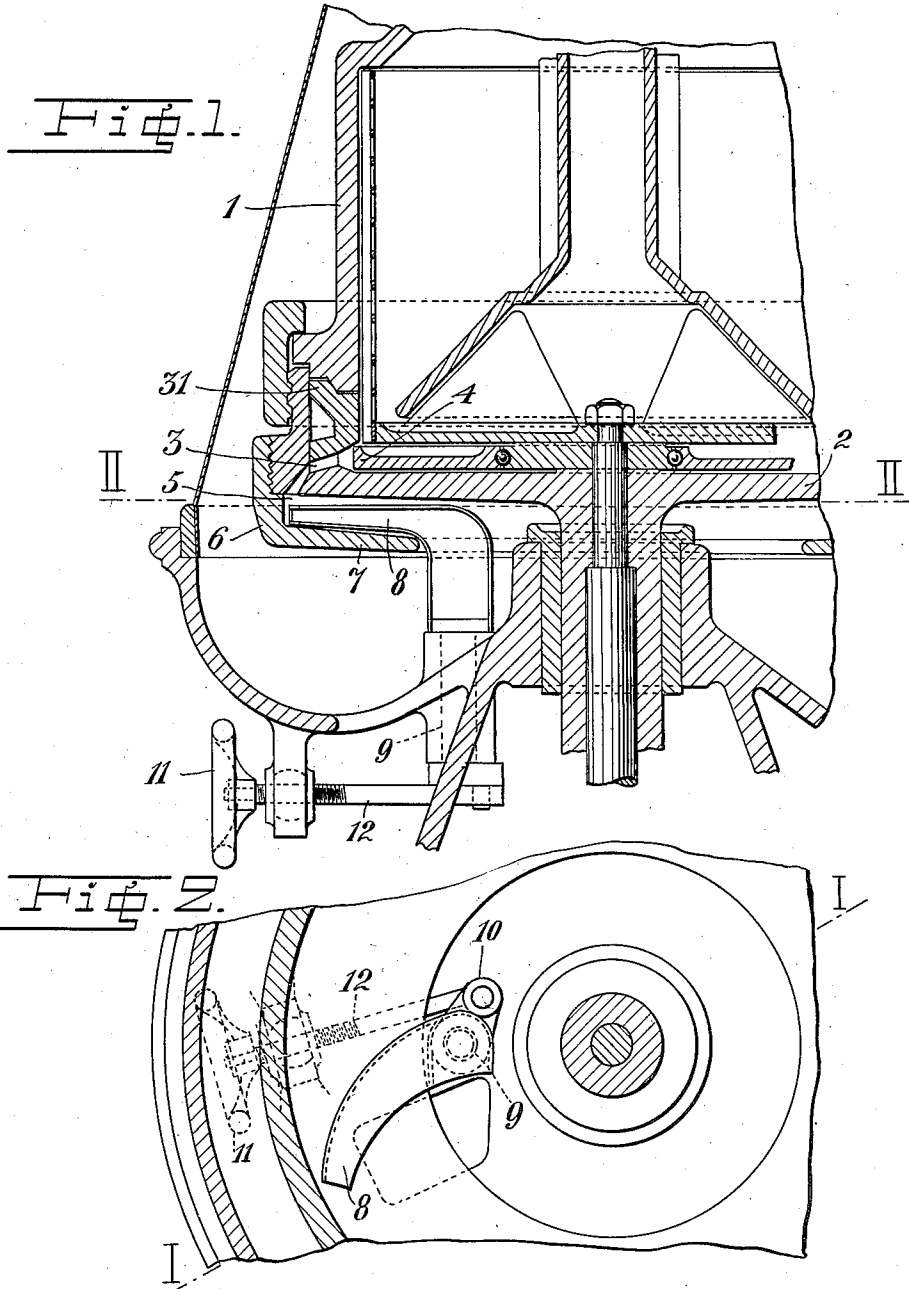

Witnesses
Karl Runeskog
Elin Anderson.

Inventor
John T. Lindahl
by Bergdahl
Atty

UNITED STATES PATENT OFFICE.

JOHN TEODOR LINDAHL, OF STOCKHOLM, SWEDEN, ASSIGNOR OF ONE-HALF TO CARL AXEL HALLING, OF STOCKHOLM, SWEDEN.

CENTRIFUGAL SLIME-SEPARATOR.

No. 884,830.

Specification of Letters Patent.

Patented April 14, 1908.

Application filed June 20, 1906. Serial No. 322,535.

To all whom it may concern:

Be it known that I, JOHN TEODOR LINDAHL, a subject of the King of Sweden, and resident of Linnégaten 15, Stockholm, Sweden, have invented a new and useful Improvement in Centrifugal Slime-Separators, of which the following is a specification, reference being had to the drawing accompanying and forming a part hereof.

The present invention relates to improvements in such centrifugal separators for separating matters suspended in liquids, such as slime from water, in which the slime, or the like, is fed out through apertures in or near the periphery.

The object of the invention is to facilitate the cleansing of the slime passages.

The invention consists, chiefly, in forming the slime passages partly by openings in the bottom of the drum, partly by recesses in a ring placed on the said bottom and fitting tightly against a flange extending upwardly from the said bottom, and partly by a ring attached to the outer side of the said flange and extending inwardly beneath the bottom of the drum.

The invention is illustrated in the accompanying drawing showing one form thereof.

Figure 1 shows a vertical section of a separator drum according to this invention, on line I—I of Fig. 2, parts of no importance to the invention being removed. Fig. 2 shows a portion of a horizontal section on line II—II of Fig. 1, certain parts being cut away.

Referring to the drawing, the apparatus consists of a centrifugal drum 1 with a bottom 2 at the periphery of which are arranged passages 3 which pass through a ring 31 inserted between the drum 1 and its bottom 2, and through which the slime separated in the drum during its operation is forced out, for instance, by the rolling action of one or more disks 4. The exterior orifices of the said passages 3 terminate in an annular space 5 below the bottom of the drum, said space being formed by a ring 6 screwed onto, or otherwise secured to, the bottom 2 and provided with an annular flange 7 passing inwards under the bottom 2. The inner edge of said flange may reach inside of the inner free liquid-level or the liquid-outlets of the centrifugal drum, whereby is gained that no liquid can ordinarily flow out of the apparatus through the slime-outlets, since the slime in space 5 is forced outwards by the

centrifugal action and thus counteracts the pressure of the liquid in the interior of the drum, while on the other hand the slime can without difficulty be forced out of the drum an arbitrary distance towards the axis of rotation through the space 5. Also in the case that no slime is present in the passages 3, or that the slime therein is so loose that it does not keep them tightly closed, the arrangement of the flange 7 as described will prevent discharge of liquid from the apparatus over the flange 7, since the level of liquid in space 5 will in this case adjust itself at the same radial distance as within the drum. It is not necessary however, to let the flange 7 extend nearer the axis of rotation than the inner free liquid level in the drum, a satisfactory closure being obtained with comparatively large discharge-passages even if the flange be of less width than is specified above. In order to facilitate the removal of the slime fed out of the passages when such a space formed by a flange protruding beneath the bottom of the drum is employed, one or more scrapers or cutters 8 may be used, for instance in the shape of curved and arched vanes, or the like, which may be journaled so as to turn on a pin 9 on the frame of the apparatus and which, by means of a crank 10 and a threaded link 12 provided with a hand-wheel 11, or the like, may be swung more or less into the space formed by the flange 7. Evidently other devices may be employed for moving the scrapers more or less into the space 5, for instance, a slide, or the like, carrying the scraper and being movable radially or more or less obliquely to the radius. The scraper may be stationary or it may be made rotating, though at another velocity than the drum, so as to give it a certain velocity relatively to the latter and enable it to cut and remove the mass fed out to a depth depending on their adjustment in relation to the axis of rotation. The adjustment of the scraper 8 can take place while the apparatus is running, and it should be so gaged to the consistency of the mass that the layer contained in space 5 will be as thin as is feasible with a view to retaining a liquid-tight closure of the slime-outlets.

Having now described my invention, I claim:

The combination with a centrifugal slime separator, of a bottom-forming an upwardly projecting annular flange and having a series

of holes extending through the said bottom, a ring placed upon the said bottom and fitting tightly against the inner side of the flange thereon, said ring being formed, at
5 its lower side, with recesses corresponding to the holes of the bottom, and a ring attached to the outer side of the said flange and extending inwardly beneath the bottom of the
10 side of the said bottom, an inward extension

of the passages leading from the circumference of the lower part of the interior of the drum, substantially as and for the purpose set forth.

In witness whereof I have hereunto set my hand in the presence of two witnesses. 15

JOHN TEODOR LINDAHL.

Witnesses:

KARL RUNCCKOG,
ELIN ANDERSON.