

W. H. JACOBY.

Improvement in Vises.

No. 132,402.

Patented Oct. 22, 1872

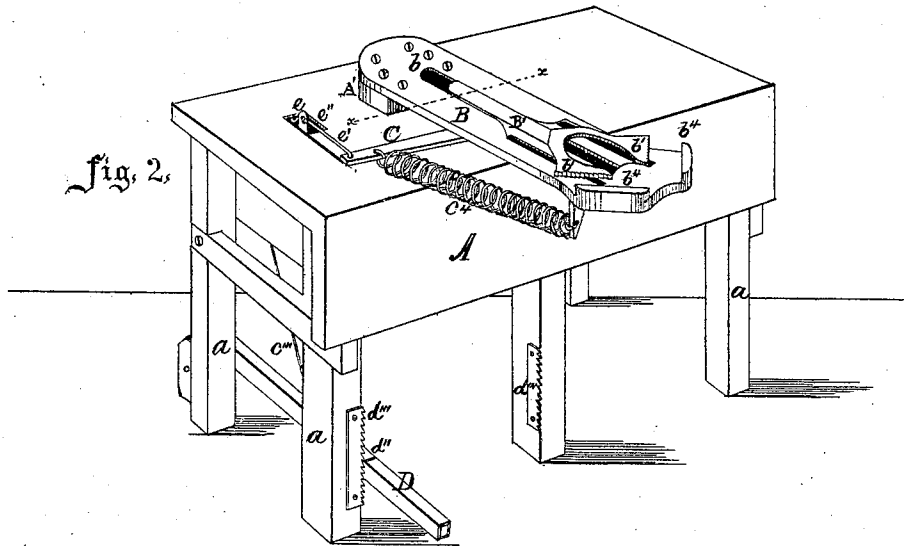
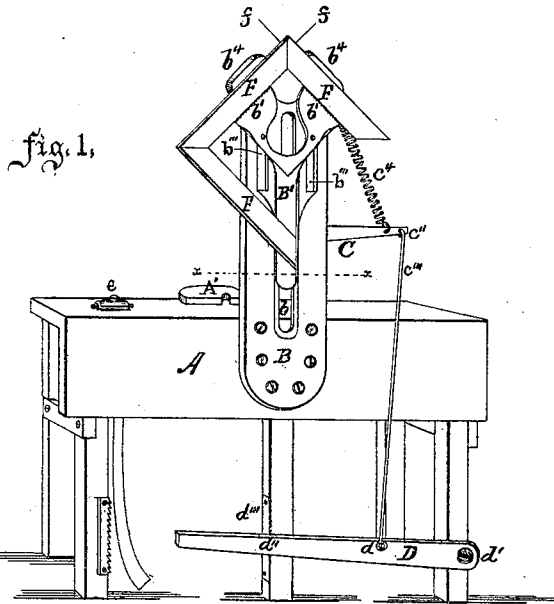

Attest
Geo. Lumber
A. Pacey

Inventor
Wm. H. Jacoby
 By *A. Crawford*
 atty.

W. H. JACOBY.

Improvement in Vises.

No. 132,402.

Patented Oct. 22, 1872.

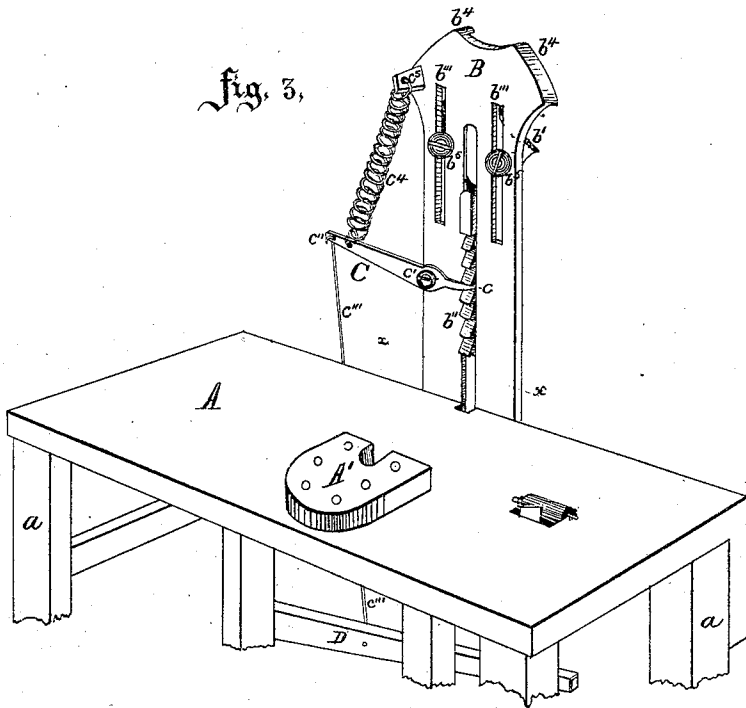

fig. 3,

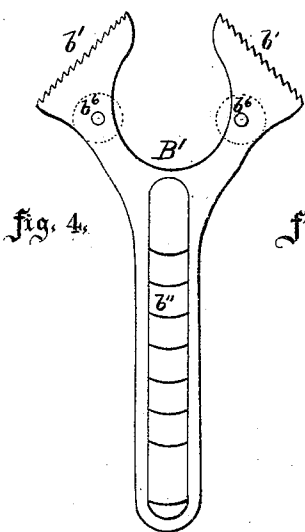

fig. 4,

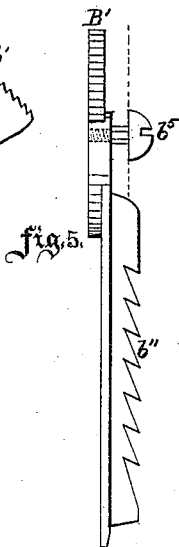

fig. 5,

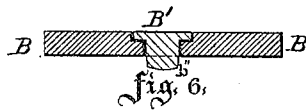

fig. 6,

Attest
J. L. Lundy
A. T. Lacey

Inventor
W. H. Jacoby
 By *A. Cranford*
att'y.

UNITED STATES PATENT OFFICE.

WILLIAM H. JACOBY, OF MINNEAPOLIS, MINNESOTA.

IMPROVEMENT IN VISES.

Specification forming part of Letters Patent No. 132,402, dated October 22, 1872.

To all whom it may concern:

Be it known that I, WILLIAM H. JACOBY, of Minneapolis, in the county of Hennepin, in the State of Minnesota, have invented certain Improvements in Vises or Clamps for holding miter-jointed pieces of wood in position to be secured in place, of which the following is a specification:

The object of this invention is to introduce into use a vise or clamp that will securely hold two pieces that are cut to a miter-joint while such pieces are being nailed, pinned, or feathered together; and it consists in the construction of the parts and their arrangement whereby the object is perfected, as will more fully hereinafter be described.

In the drawing, Figure 1 is an upright front view of the clamp or vise fast to the side of the work-bench; Fig. 2 shows the clamp or vise in horizontal position on top of the bench; Fig. 3 is a back-side view of the clamp or vise in upright position; Figs. 4 and 5, enlarged details; and Fig. 6, cross-section on *xx* of Figs. 1 and 2.

A is a work-bench of ordinary construction and supported on legs *aa*. B is the standing or fixed part of the vise or clamp, which is preferably constructed of metal, having slot *b* centrally therein, two side slots, *b''' b''''*, parallel thereto, and smooth-faced flanges *b⁴* projecting from the inclined top parts of part B, which form the outer part of the clamping or holding jaws of the vise. B' is a sliding part, bifurcated near its upper end, each part terminating in angular serrated jaws *b' b'*, while the lower body part has a backward projection that fits and slides in slot *b* of stationary part B, and projecting back far enough to have the teeth or notches *b''* clear of the back side of part B. *b⁵ b⁵* are screws that are turned into the sliding part B' at *b⁵ b⁵* through slots *b'''* in fixed part B. The heads of the screws sliding against the back side of part B prevent the sliding part B' from separating from part B, but allow part B' to freely slide in the open slot *b*. C is a lever pivoted at *c'* to part B, with its short end shaped to take hold of the notches *b''* on the sliding part B', as seen at *c*, Fig. 3, while to the long end at *c''* is attached a connecting-rod, *c'''*, which connects at *d* to treadle D that is pivoted at *d'* to leg *a* of the bench A. *c⁴* is a spring attached at its upper end to the fixed part B, and at the lower end to lever C. *d''* is a plate on treadle-lever D, and of the proper form to take

into teeth or notches on plate *d''* on the leg *a* of bench A, and hold the clamp in position.

This vise or clamp can be used in a horizontal as well as in upright position, by securing the lower end of the stationary part B upon block A' on the top of bench A, and to do this only requires a rod, *e'*, to connect the lever C with a bell-crank, *e*, the upper end of which projects up through hole *e''* in the top of bench A, while the connecting-rod *e'''* connects the other end of the bell-crank with the treadle-lever D, as seen in Fig. 2.

This vise or clamp is especially designed for securely holding two sides or parts of a frame that are mitered together at their meeting-angles while the parts are being permanently nailed or feathered, and in Fig. 1 is shown the mitered pieces that form a frame being put together and held in the vise or clamp while the nails or feathers are inserted. F represents the side pieces that compose the frame firmly clamped to a joint at the meeting-angles, and held in such position while the nails *f* are driven through one side into the other to hold them in contact and together, as the sliding part B', with its angular serrated jaws *b'*, takes hold of the inner edge of the two pieces and forces them together at their meeting-angles, and clamps them against the projecting jaws *b⁴* on the fixed part B by the action of forcing the treadle-lever D down by the foot, when the plate *d''* on the treadle-lever will engage a notch in plate *d'''* on leg *a*, and the pieces F will be securely clamped in proper position for nailing or otherwise holding the joint firmly in place.

Having thus described my invention, what I claim, and desire to secure by Letters Patent, is—

1. The fixed or stationary part B having slots *b* and *b''' b''''* therein and projecting angular jaws *b⁴ b⁴*, and the sliding part B' having serrated jaws *b' b'*, and constructed to slide in the slot *b* of part B, and secured thereto in the manner and for the purpose substantially as described.

2. The combination of the treadle-lever D, rod *c'''*, lever C, and sliding part B' with the stationary part B, constructed and operating substantially in the manner and for the purpose described.

WILLIAM H. JACOBY.

Witnesses:

H. J. JACOBY,
CHAS. H. WOODS.