

No. 710,598.

Patented Oct. 7, 1902.

W. C. MONTZER.
SIPHON.

(Application filed May 11, 1901. Renewed Mar. 15, 1902.)

(No Model.)

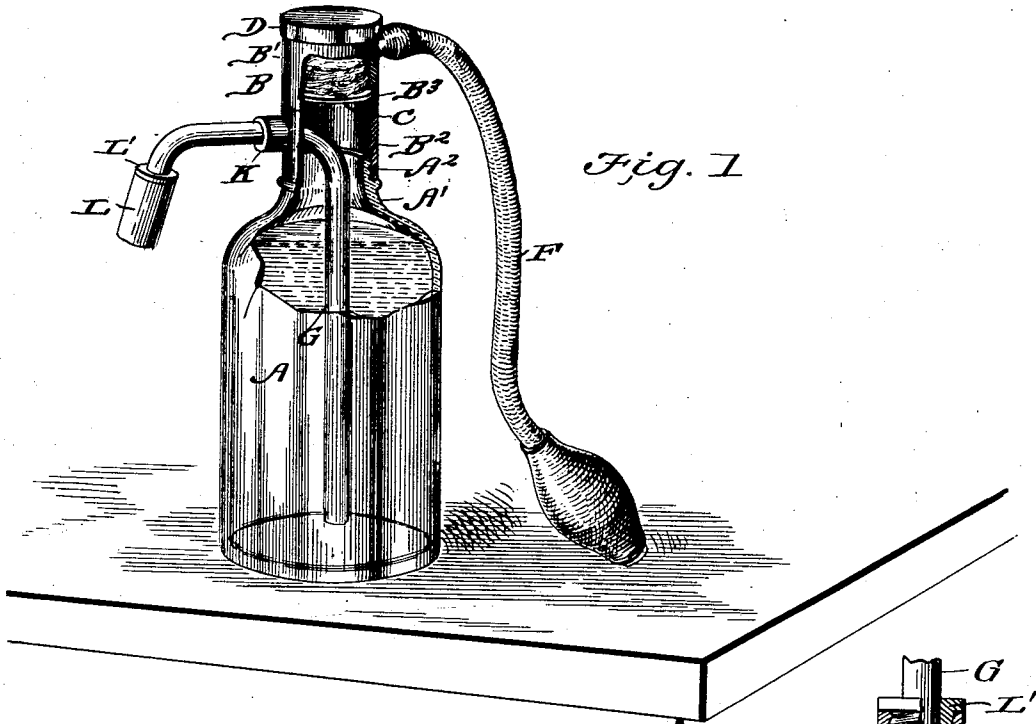

Fig. 1

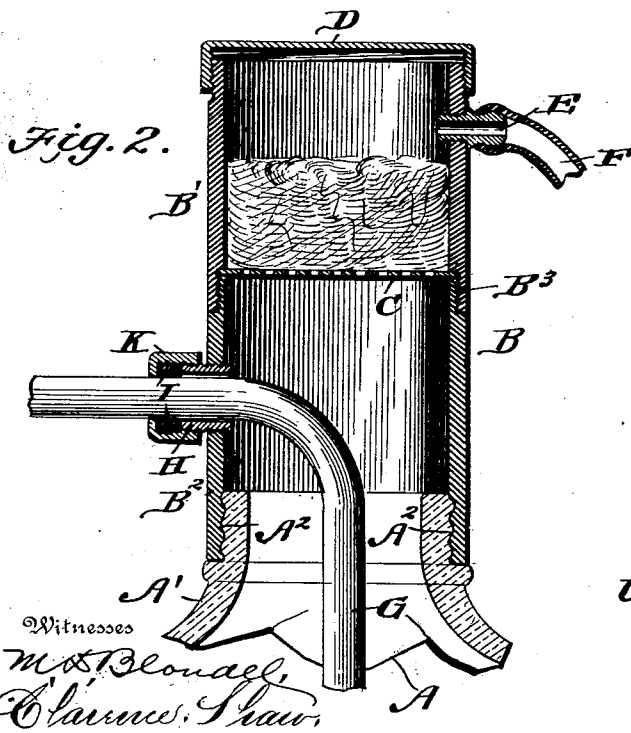

Fig. 2.

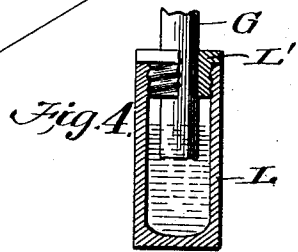

Fig. 4.

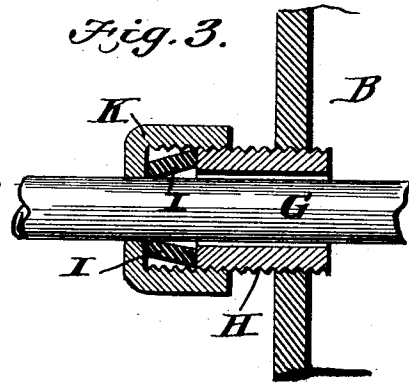

Fig. 3.

Witnesses
M. S. Blouell,
Charles Shaw.

Inventor
William C. Montzer.
By
O. M. ...
Attorneys

UNITED STATES PATENT OFFICE.

WILLIAM C. MÜNTZER, OF SAN ANTONIO, TEXAS.

SIPHON.

SPECIFICATION forming part of Letters Patent No. 710,598, dated October 7, 1902.

Application filed May 11, 1901. Renewed March 15, 1902. Serial No. 98,409. (No model.)

To all whom it may concern:

Be it known that I, WILLIAM C. MÜNTZER, a citizen of the United States, residing at San Antonio, in the county of Bexar and State of Texas, have invented a new and useful Siphon, of which the following is a specification.

This invention relates generally to siphon-bottles, and more particularly to an aseptic siphon attachment adapted for use in connection with bottles, the object being to provide a simple and efficient attachment for the purpose of preserving solutions of citrate of magnesia, distilled water, various infusions, and other liquids subject to change.

With these objects in view the invention consists, essentially, in arranging a supplemental neck upon the liquid-containing vessel, said neck being divided into two compartments, one being adapted to receive a filtering medium through which air is forced, the other section having the delivery-tube passing therethrough.

The invention consists also in certain details of construction and novelties of combination, all of which will be fully described hereinafter and pointed out in the claim.

In the drawings forming part of this specification, Figure 1 is a view showing the practical application of my invention. Fig. 2 is a vertical sectional view of the attachment, and Fig. 3 is an enlarged sectional view showing the manner of securing the packing around the discharge-tube. Fig. 4 shows a detail construction.

In carrying out my invention I employ a bottle A, having a short neck A' threaded upon the exterior, as shown at A², and having a shoulder A³ arranged at the lower end of the threaded portion A². A supplemental neck B is screwed upon the threaded neck A², said supplemental neck consisting of the upper section B¹ and the lower section B², said sections being united at B³ by means of a shouldered screw-joint, and interposed between the sections B¹ and B² is the perforated diaphragm C.

Screwed cap D is screwed upon the top of the upper section B¹, and a nipple E is screwed into the side of the upper section adjacent to the upper end, and an air-supply tube F is at-

tached to the said nipple, so that air can be forced into the upper receptacle B¹, said receptacle being partially filled with cotton or other filtering material.

The liquid-discharge tube G extends down into the bottle A and is curved or bent adjacent to its upper end and projected laterally through the lower section of the supplemental neck, said tube passing through a collar H, screwed into the side of the supplemental neck, said collar being preferably constructed of hard rubber or metal, and a conical packing-ring or washer I surrounds the glass tube G and rests against the outer end of the collar H, and a gasket K is screwed upon the collar H and compressing the soft-rubber conical washer or ring and making an absolutely air-tight joint where the discharge-tube passes from the supplemental neck. The supplemental neck may be made of hard rubber or metal, as preferred, and all the various parts connected thereto may be made of metal or rubber, as preferred, with the exception of the discharge-tube G and the soft-rubber packing I. By forcing air into the upper section and filtering the same before it passes down into the bottle proper it will be seen that absolutely pure air is employed for the purpose of forcing the liquid out of the bottle, and by constructing the supplemental neck in this manner I am enabled to preserve the contents of the bottle against deterioration.

In order to prevent crystallization, I connect a water seal to the outer end of the discharge-tube, as most clearly shown in Fig. 4, in which L indicates a thimble, and L' a stopper fitted into the end thereof and through which the end of the pipe passes.

Having thus fully described my invention, what I claim as new, and desire to secure by Letters Patent of the United States, is—

In a device of the kind described, the combination with the bottle having a short threaded neck, of a supplemental neck secured upon the threaded neck of the bottle proper, said supplemental neck being composed of two sections united by a screwed joint, the perforated diaphragm arranged between the upper and lower sections, the screwed top ar-

ranged upon the upper section, the nipple leading into the upper section and having an air-pipe connected thereto, the liquid-discharge pipe passing through the side of the lower section, the collar through which said tube passes, the soft-rubber packing and the gasket for compressing and holding the soft-

rubber packing in place, substantially as shown and described.

WILLIAM C. MÜNTZER.

Witnesses:

W. B. ANDERSON,
J. C. DUNCAN.