



INTERNATIONAL APPLICATION PUBLISHED UNDER THE PATENT COOPERATION TREATY (PCT)

<p>(51) International Patent Classification ⁵ : F04D 29/54, 29/16</p>	<p>A1</p>	<p>(11) International Publication Number: WO 91/06779 (43) International Publication Date: 16 May 1991 (16.05.91)</p>
<p>(21) International Application Number: PCT/US90/02119 (22) International Filing Date: 18 April 1990 (18.04.90) (30) Priority data: 430,185 1 November 1989 (01.11.89) US (71)(72) Applicants and Inventors: SCOATES, William, D. [US/US]; SCOATES, Samuel, W. [US/US]; 202 College View Street, Bryan, TX 77801 (US). (74) Agent: THOMPSON, Jennings, B.; Vaden, Eickenroht, Thompson & Boulware, One Riverway, Suite 1100, Houston, TX 77056 (US).</p>		<p>(81) Designated States: AT (European patent), AU, BE (European patent), CH (European patent), DE (European patent)*, DK (European patent), ES (European patent), FR (European patent), GB (European patent), IT (European patent), JP, LU (European patent), NL (European patent), SE (European patent).</p> <p>Published <i>With international search report.</i></p>
<p>(54) Title: SHROUD ASSEMBLY FOR AXIAL FLOW FANS</p>		
<p>(57) Abstract</p> <p>An axial fan is disclosed that includes a hub (10) supported for rotation around the longitudinal axis of the fan, a plurality of impeller blades (12) attached to the hub (16) and extending radially from the axis of rotation, a shroud assembly (34) including a band (36) encircling the blades (12) and spaced from the tips of the blades (12) a sufficient distance to provide ample clearance to avoid contact between the blades (12) and the band (36) during shipment and operation of the fan, the shroud (34) further including an orifice (38) positioned upstream of the blades (12) for preventing air from flowing between the orifice (38) and the band (36), the orifice (38) having a downstream end located adjacent to but spaced from the impeller blades (12) and having a diameter such that the impeller blades (12) extend outwardly from the hub (10) beyond the orifice (38) so that the flow of air over the tips of the impeller blades (12) is substantially reduced, which increases the efficiency of the fan.</p>		

DESIGNATIONS OF "DE"

Until further notice, any designation of "DE" in any international application whose international filing date is prior to October 3, 1990, shall have effect in the territory of the Federal Republic of Germany with the exception of the territory of the former German Democratic Republic.

FOR THE PURPOSES OF INFORMATION ONLY

Codes used to identify States party to the PCT on the front pages of pamphlets publishing international applications under the PCT.

AT	Austria	ES	Spain	MG	Madagascar
AU	Australia	FI	Finland	ML	Mali
BB	Barbados	FR	France	MR	Mauritania
BE	Belgium	GA	Gabon	MW	Malawi
BF	Burkina Faso	GB	United Kingdom	NL	Netherlands
BG	Bulgaria	GR	Greece	NO	Norway
BJ	Benin	HU	Hungary	PL	Poland
BR	Brazil	IT	Italy	RO	Romania
CA	Canada	JP	Japan	SD	Sudan
CF	Central African Republic	KP	Democratic People's Republic of Korea	SE	Sweden
CG	Congo			SN	Senegal
CH	Switzerland	KR	Republic of Korea	SU	Soviet Union
CI	Côte d'Ivoire	LI	Liechtenstein	TD	Chad
CM	Cameroon	LK	Sri Lanka	TG	Togo
DE	Germany	LU	Luxembourg	US	United States of America
DK	Denmark	MC	Monaco		

SHROUD ASSEMBLY FOR AXIAL FLOW FANS

This invention relates to axial flow fans, generally, and in particular to an improved shroud assembly for such fans.

As the impeller blade of a fan moves through a fluid, such as air, pressures on opposite sides of the blade are different. This pressure differential will cause the fluid to flow over the tip of the blade from the discharge or high pressure side of the blade to the intake side or low pressure side of the blade thus forming a vortex. This reduces the efficiency of the fan. The conventional approach to reducing or preventing this flow of air, is to provide some sort of seal between the blade tip and the shroud, which usually involves reducing the clearance between the blade tip and the shroud to a minimum. For example, see Langenkamp et al U.S. Patent No. 2,030,993 and Robb et al U.S. Patent No. 4,406,581. Also see Figure 7, where the importance of reducing tip clearance to improve fan efficiency is demonstrated.

The problem, however, is that it is very difficult to manufacture, ship, install, and operate satisfactorily a fan having a small clearance between the blades and the shroud, since it requires an almost perfect balancing of the rotating

hub and blades, almost perfect centering of the rotating hub and blades in the shroud, and an almost perfectly round opening in the shroud. Therefore, as a practical matter, commercial fans are provided with enough tip clearance to operate even though the hub and blades are not perfectly balanced, the blades are not all the exact same length, the hub is not perfectly centered, and the opening in the shroud is not perfectly round. This compromise does, of course, reduce the efficiency of the fan.

It is an object of this invention to provide an axial fan having the efficiency of a low fan tip clearance fan without the problems described above.

It is a further object of this invention to provide an axial fan in which there is substantially no pressure differential between opposite sides of the blades adjacent the blade tips thereby substantially eliminating the flow of air over the blade tips and the forming of a vortex.

It is a further object of this invention to provide such an axial fan where the tips of the fan blades travel in a space where there is little or no movement of air thereby reducing substantially the effect of tip clearance on fan efficiency.

It is a further object of this invention to provide an axial fan having a shroud assembly that includes a cylindrical section or band that encircles the fan blades and is spaced therefrom and an orifice section having its downstream edge adjacent to but spaced from the impeller blades, which extend outwardly beyond the downstream edge of

the orifice into a zone of non-moving air. The air moves out of the way of the blade tips, of course, but does not move much relative to the space through which the blade tips move.

United States Patent No. 4,515,071, which issued to Elmer S. Zach on May 7, 1985 and is entitled "Ventilation Air Control Unit" discloses an axial fan having a shroud assembly that includes a cylindrical section or band that encircles the fan blades and is spaced therefrom and an orifice section having its downstream edge adjacent to but spaced from the impeller, which extend outwardly beyond the downstream edge of the orifice into a zone of non-moving air. This structural arrangement resulted when Zach replaced a twelve inch ventilating fan with a fourteen inch fan for forcing air into a grain drying and storing bin for drying and ventilating the grain in the bin.

Zach teaches use of a flange or orifice having an inner diameter less than the overall span of the fan blade for redirecting the flow of air away from the tips of the fan blade and toward its center (claim 4, lines 18 et seq.).

It is an object of this invention to provide an axial fan with an orifice, fan blade, and a band or cylindrical section encircling the fan blade and orifice, the diameters of which have a fixed relationship within a range and that substantially eliminates the flow of air over the tips of the fan blades which substantially reduces the effect of tip clearance on the efficiency of the fan, thereby allowing the tips of the fan blades to be spaced from the band

sufficiently to avoid the manufacturing, shipping, installation, and operating problems described above.

Specifically, it is a further object and feature of this invention to provide an axial fan having an orifice, a fan blade, and a band wherein the diameter of the fan blade is about 103% of the diameter of the orifice and the diameter of the band is about 106% of the diameter of the orifice, which substantially eliminates the effect of tip clearance or fan efficiency and provides ample clearance between the tip of the fan blade and the band to substantially eliminate damage to the fan blade as a result of a reduction of such clearance in an effort to improve fan efficiency.

These and other objects, advantages, and features of this invention will be apparent to those skilled in the art from a consideration of this specification, including the attached drawings and appended claims.

In The Drawings:

Figure 1 is a view of the discharge side of a fan constructed in accordance with the preferred embodiment of this invention.

Figure 2 is a sectional view taken along line 2--2 of Figure 1.

Figure 3 is a view of the intake side of the fan of Figure 1.

Figure 4 is a partial sectional view of an alternate embodiment of the invention.

Figure 5 is a graph of the performance data of three fans, and

Figures 6A, 6B, and 6C show the arrangement of the fans and the shrouds that produced curves A, B, and C of Figure 5, Figure 6C being the fan that embodies this invention.

Figure 7 is a graph showing the effect of tip clearance on fan efficiency.

The fan of Figures 1, 2, and 3 includes hub 10 to which four impeller blades 12 are attached. Preferably, the blades are curved along their transverse axes to provide concave surfaces facing the discharge side of the fan, as shown in Figure 2. Hub 10 is mounted on shaft 14. The shaft is supported for rotation around its longitudinal axis by bearings 16 and 18 that are mounted on end plates 20 and 22 of bearing housing 24. The hub, the shaft, the bearings, and bearing housing are supported in the center of rectangular fan casing 26 by support vanes 28 that extend between the bearing housing and the fan casing. Sheave 30 mounted on shaft 14 on the outside of bearing housing 24 is rotated by belt 32 which in turn rotates hub 10 and the impeller blades. Belt 32 is driven by an electric motor that is usually mounted on the fan casing. The motor is not shown.

In accordance with this invention, the fan is provided with shroud assembly 34 that includes cylindrical section or band 36 and orifice section 38. The cylindrical section is attached to and supported by orifice section 38. The orifice section in turn is connected to rectangular fan casing 26. In the embodiment shown, the orifice section is an integral

part of the front wall of the fan casing. It curves toward the center of the fan casing and rearwardly toward impeller blades 12, as shown, to provide a nozzle shaped guide for the air flowing through the fan. Although it need not do so, the orifice section shown straightens out and becomes cylindrical as it approaches the impeller blades to provide a section of uniform diameter through which the air flows before reaching the impeller blades.

In accordance with this invention, the impeller blades extend outwardly beyond the orifice section with the tips of the blades adjacent to but spaced from the cylindrical section of the shroud, as shown in Figure 2. This arrangement provides annular space 40 between the orifice section and the cylindrical section in which the air does not move substantially. Consequently, there is little pressure differential between the sides of the impeller tips which results in substantially no radial flow of air over the tips of the blades. Therefore, there is no need for the tips of the blades to be close to the shroud to obtain the greatest efficiency for the fan. This is shown by the results of comparative tests on three fans, one of which being constructed in accordance with this invention.

The best method to use in evaluation of the improved performance of the fan of this invention (fan C), shown in curves "C" of the attached curve sheet, is the use of "system resistance" curves to make the performance of present technology (curves "A" and "B") equal the performance of the

improved fan (curves "C"). Each fan had an orifice that was 25" in diameter.

As shown in Figures 6A, 6B, and 6C, the impeller blades of fan A are located inside the orifice with the blade tips spaced 0.341 inches from the orifice. Fan B also has its blades located inside the orifice, but the blade tips are much closer to the orifice, i.e., about 0.171 inches. Fan C has its shroud and blades positioned in accordance with this invention with the end of the orifice spaced about 0.75 inches from the cylindrical section, i.e., the cylindrical section has a diameter that is 106% of the diameter of the orifice. The fan blades extend beyond the orifice about 0.375 inches, i.e., the diameter of the blades is about 103% of the diameter of the orifice. The forward edge of each blade is about 0.25 inches from the end of the orifice. Obviously, substantial clearance is provided between the stationary and moving parts of the fan.

"System resistance" is the resistance to air flow when a fan or blower is attached to a fixed duct system. Changes in performance are then made by application of "fan laws". The "system resistance curves" in this instance are parabolic curves with the origin at zero for CFM and static pressure (Ps).

Table I below shows four different performances of fan C at four different static pressures (Ps). The static pressures were 0.000", 0.125", 0.250", and 0.375". Generally, 80% of commercial fan sales are for performances

at static pressures (Ps) of 0.125" and 0.250", and 20% would be static pressures (Ps) of 0.000" (Free Air) and 0.375".

TABLE I

Performance of Improved Fan (Curve "C")

CFM:	6629	6050	5400	4600
RPM:	1150	1150	1150	1150
Ps:	0.000"	0.125"	0.250"	0.375"
BHP:	0.422	0.48	0.531	0.575
Static Eff:	0.0%	24.8%	40.0%	47.2%

Each of the four static pressures of fan C has a different "system resistance curve". These "system resistance" curves can be calculated by the following equation:

$$\text{cfm} = \text{constant} \sqrt{\text{Ps}} \quad (1)$$

or

$$\frac{\text{cfm}}{\sqrt{\text{Ps}}} = \text{constant} \quad (2)$$

For curve "C", the constants are:

Ps:	0.000	0.125"	0.250"	0.375"
Constant:	0	17112	10800	7512

cfm is in cubic feet per minute

Ps (static pressure) is in inches of water

Three of these "system resistance curves" for Ps = 0.125", 0.250", and 0.375" are plotted in dashed lines in Figure 5.

The "system resistance curve" for $P_s = 0.000"$ (Free Air) is a special case because $P_s = 0$. Therefore, the constant in the above equation is also equal to 0. Then:

$$\frac{\text{CFM of curve "C" @ } P_s = 0}{\text{CFM of curve "A" or "B" @ } P_s = 0} = K_1$$

$$K_1 \times 1150 = \text{new RPM for curve "A" or "B"}$$

$$(K_1)^2 \times 0.000" = \text{new } P_s \text{ for curve "A" or "B" } = 0$$

$$(K_1)^3 \times \text{BHP for curve "A" or "B" - new BHP for curve "A" or "B" @ New RPM}$$

Figure 5 shows curves for Volume (CFM) vs Static Pressure (PS), Volume (CFM) vs Horsepower (BHP), and Static Efficiency vs Volume (CFM) for the fans of present technology (Curves "A" and "B") and the improved fan (Curve "C").

Calculated values of CFM and PS where the "system resistance curves" intersect the performance curves of "A" and "B" can be determined by applying constants of Curve "C" in equation (2). By consulting Figure 5, the values of BHP are manually read from the Volume (CFM) vs Horsepower (BHP) curve, of Figure 5, at the CFM calculated for the intersection of "system resistance curve" and Curves "A" and "B".

Curve "A" Performance Data at the Intersection of "System Resistance Curves" of Curve "C"

CFM	5462	5047	4582	3989
PS	0.000"	0.087"	0.180"	0.282"
BHP	0.360	0.405	0.43	0.443

Curve "B" Performance Data at the Intersection of the
"System Resistance Curves" of Curve "C"

CFM	5769	5384	4902	4335
PS	0.000"	0.099"	0.206"	0.333"
BHP	0.369	0.405	0.446	0.481

There are certain well recognized engineering laws derived from engineering fundamentals that apply to all centrifugal and axial flow machinery performance. These are called "Fan laws" by those skilled in the art.

The "fan laws" are now employed to compare the performances of fans "A" and "B" (curves A and B) to the performance of fan C (curve "C") for the four static pressures shown in Table I.

The "fan laws" are in this instance:

$$\begin{aligned} \text{Ratio of changes in RPM or Cfm} &= K_1 \\ \text{Ratio of changes in Static pressure} &= (K_1)^2 \\ \text{Ratio of changes in BHP} &= (K_1)^3 \end{aligned}$$

The comparison is made by moving data from curve "A" and curve "B" along "system resistance curves" to curve "C" by use of the "fan laws" as follows:

TABLE II

Performance Data for Curve "A" and Upgraded to Curve "C"

CFM:	5462	5047	4582	3989
RPM:	1150	1150	1150	1150
Ps:	0.000"	0.087"	0.180"	0.282"
BHP:	0.360	0.405	0.43	0.443
Static Eff:	0.0%	17.1%	30.2%	40.0%

$$\begin{aligned}
 \text{CFM\&RPM-K}_1 &: \left(\frac{6629}{5462}\right) = 1.2137 & \left(\frac{6050}{5047}\right) = 1.1987 & \left(\frac{5400}{4582}\right) = 1.1785 & \left(\frac{4600}{3989}\right) = 1.1517 \\
 \text{Ps (K}_1\text{)} \alpha &: \left(\frac{6629}{5462}\right)^2 = 1.4730 & \left(\frac{6050}{5047}\right)^2 = 1.4370 & \left(\frac{5400}{4582}\right)^2 = 1.3889 & \left(\frac{4600}{3989}\right)^2 = 1.3298 \\
 \text{BHP (K}_1\text{)} \beta &: \left(\frac{6629}{5462}\right)^3 = 1.7877 & \left(\frac{6050}{5047}\right)^3 = 1.7225 & \left(\frac{5400}{4582}\right)^3 = 1.6369 & \left(\frac{4600}{3989}\right)^3 = 1.5355
 \end{aligned}$$

CFM:	6629	6060	5400	4600
RPM: (+21.3%)	1396	(+19.8%) 1378	(+17.8%) 1355	(+15.2%) 1326
Ps:	0.000"	0.125"	0.25"	0.375"
BHP: (+52.4%)	0.643	(+45.4%) 0.698	(+32.5%) 0.704	(+18.1%) 0.679
Static Eff:	0.0%	(-31.2%) 17.1%	(-24.5%) 30.2%	(-8.5%) 40.0%

Evaluation of Table II shows that fan A at 0.000" (Free Air) had increased RPM by 21.3% and required more power, BHP, by 52.4%. Similar but lower increases were shown for the other static pressures: 0.125", 0.250", and 0.375". The loss in static efficiency was 31.2% at 0.125" static pressure, 24.5% at 0.250" static pressure, and 8.5% at 0.375" static pressure.

Table III shows the result when data from curve "B" is moved to equal the performance of curve "C".

TABLE III

Performance Data From Curve "B" and Upgraded to Curve "C"

CFM:	5769	5384	4902	4335
RPM:	1150	1150	1150	1150
Ps:	0.000"	0.099"	0.206"	0.333"
BHP:	0.369	0.405	.446	.481
Static Eff:	0.0%	20.7%	35.79%	47.2%

CFM&RPM:	$\left(\frac{6629}{5769}\right) = 1.1491$	$\left(\frac{6050}{5084}\right) = 1.1237$	$\left(\frac{5400}{4902}\right) = 1.1016$	$\left(\frac{4600}{4335}\right) = 1.0611$
Ps :	$\left(\frac{6629}{5769}\right)^2 = 1.3204$	$\left(\frac{6050}{5384}\right)^2 = 1.2627$	$\left(\frac{5400}{4902}\right)^2 = 1.2135$	$\left(\frac{4600}{4335}\right)^2 = 1.1260$
BHP :	$\left(\frac{6629}{5769}\right)^3 = 1.5172$	$\left(\frac{6050}{5384}\right)^3 = 1.4189$	$\left(\frac{5400}{4902}\right)^3 = 1.3368$	$\left(\frac{4600}{4335}\right)^3 = 1.1948$

CFM:	6629	6050	5400	4600
RPM: (+14.9%)	1321	(+12.3%) 1292	(+10.2%) 1269	(+6.1%) 1220
Ps:	0.000"	0.125"	0.250"	0.375"
BHP: (+32.7%)	0.560	(+19.8%) 0.575	(+7.2%) 0.596	0.575
Static Eff:	0.0%	(-16.5%) 20.7%	(-10.7%) 35.79%	47.2%

Evaluation of Table III shows that fan "B" at 0.000" (Free Air) had increased RPM by 14.9% and required 32.7% more power, BHP. Similar but lower increases were shown for static pressures of 0.125" and 0.250". At the 0.375" static pressure, however, only the RPM increased by 6.1%. Increased RPM will increase the noise level.

Tables II and III show clearly that reduction in tip clearance of the present technology will bring increased efficiencies, but this also brings on a problem of how to effectively manufacture such equipment and ship to the ultimate user.

The improved fan of this invention allows for acceptable manufacturing tolerances without loss of performance.

- 13 -

SUMMARY

Tables IV and V shown below are summaries of all percentage changes in performance when curves "A" and "B" are made equal in performance to curve "C".

TABLE IVPercentage Change to Make Curve "A" Equal Curve "C"For Curve "A":

Static pressure of Curve "C"	0.000"	0.125"	0.250"	0.37"
CFM	+21.37%	+19.87%	+17.85%	+15.17%
RPM	+21.37%	+19.87%	+17.85%	+15.17%
Ps	+47.30%	+43.7%	+38.89%	+32.99%
BHP	+52.4%	+45.4%	+32.5%	+18.1%
Static Eff.	none	-31.1%	-24.5%	- 8.5%

TABLE VPercentage Change to Make Curve "B" Equal Curve "C"For Curve "B":

Static pressure of Curve "C"	0.000"	0.125"	0.250"	0.375"
CFM	+14.91%	+12.37%	+10.16%	+6.11%
RPM	+14.91%	+12.37%	+10.16%	+6.11%
Ps	+32.04%	+26.27%	+31.35%	+12.6%
BHP	+32.7%	+19.8%	+7.2%	none
Static Eff.	none	-16.5%	-10.7%	none

Figure 4 is an alternate embodiment of this invention. Structurally, it is the same as the embodiment in Figures 1, 2, and 3 with the addition of annular bracket 42 to support and connect the rearward edge of the orifice section to the cylindrical section. This embodiment does not perform as well as the preferred embodiment, but better than fans A and B.

From the foregoing it will be seen that this invention is one well adapted to attain all of the ends and objects

hereinabove set forth, together with other advantages which are obvious and which are inherent to the apparatus and structure.

It will be understood that certain features and subcombinations are of utility and may be employed without reference to other features and subcombinations. This is contemplated by and is within the scope of the claims.

Because many possible embodiments may be made of the invention without departing from the scope thereof, it is to be understood that all matter herein set forth or shown in the accompanying drawings is to be interpreted as illustrative and not in a limiting sense.

WHAT IS CLAIMED IS:

1. An axial fan comprising a hub, means supporting the hub for rotation around the longitudinal axis of the fan, a plurality of impeller blades attached to the hub and extending radially from the axis of rotation, a shroud assembly including a band encircling the blades and spaced from the tips of the blades a sufficient distance to provide ample clearance to avoid contact between the blades and the band during shipment and operation of the fan, said shroud further including an orifice positioned upstream of the blades, said band having a diameter that is about 106% of the diameter of the orifice means for preventing air from flowing between the orifice and the band, said orifice having a downstream end located adjacent to but spaced from the impeller blades, said impeller blades having a diameter that is about 103% of the diameter of the orifice so that the impeller blades extend outwardly from the hub beyond the orifice to reduce the flow of air over the tips of the impeller blades substantially while providing ample clearance between the tips of the impeller blades and the band.

2. An axial fan comprising, a rotatable fan hub, a plurality of impeller blades carried by the hub, a fan casing for supporting the hub and blades, said casing further supporting a fan blade shroud assembly including a cylindrical band that extends from the casing over the blades and an orifice that decreases to a diameter less than the diameter of the circular path of the tips of the blades and

extends to a position adjacent to but spaced from the blades to combine with the band to provide an annular space having little or no air movement in which the tips of the blades move as the blades are rotated to thereby reduce substantially the radial flow of air over the tips of the impeller blades and thereby increase the efficiency of the fan, the diameter of the band being about 106% of the diameter of the orifice and the diameter of the blades being about 103% of the diameter of the orifice.

3. The axial fan of claim 2 in which the impeller blades are spaced from the end of the orifice about .250 inches.

1/4

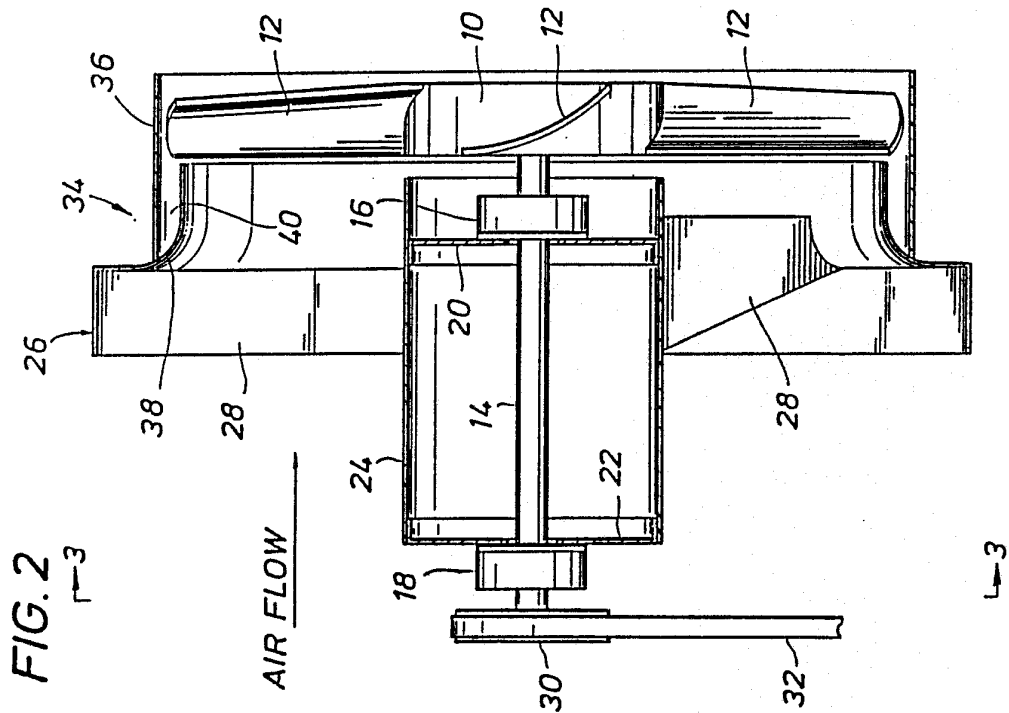
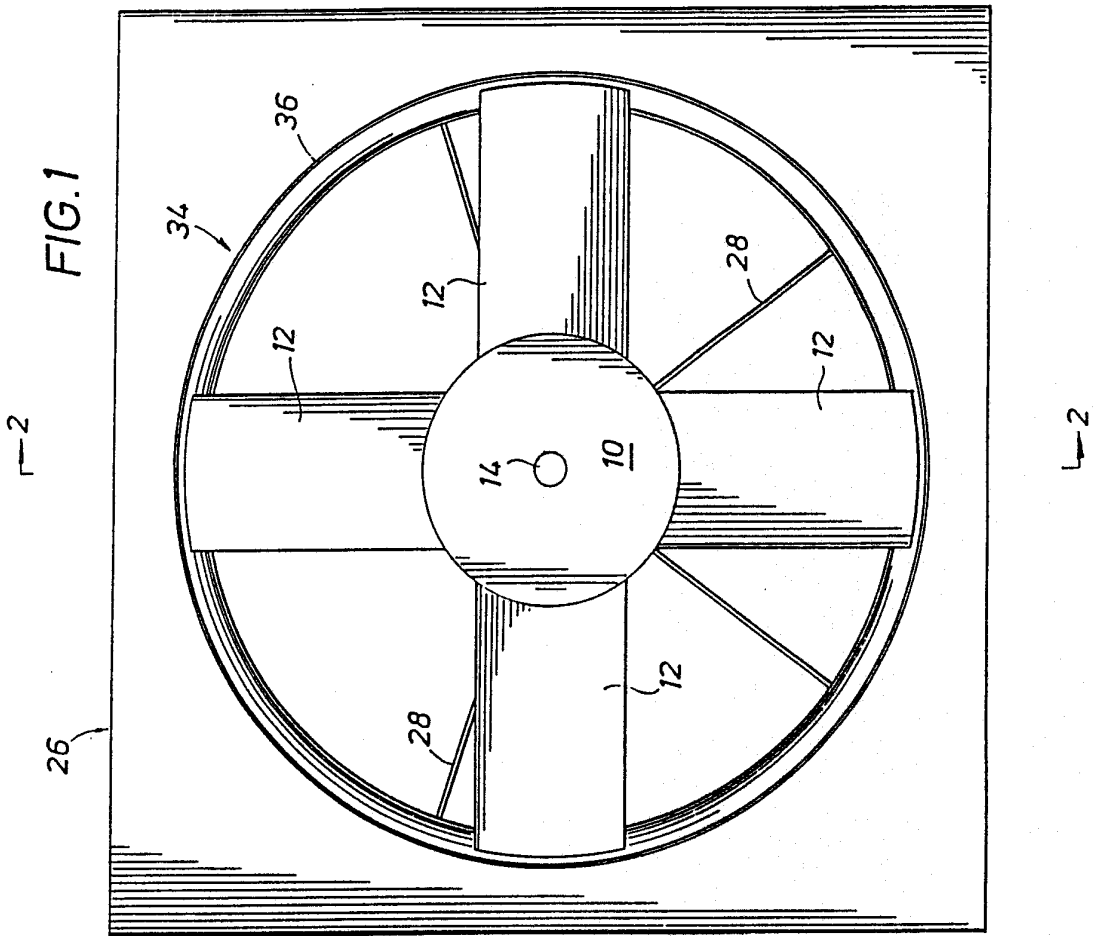

2/4

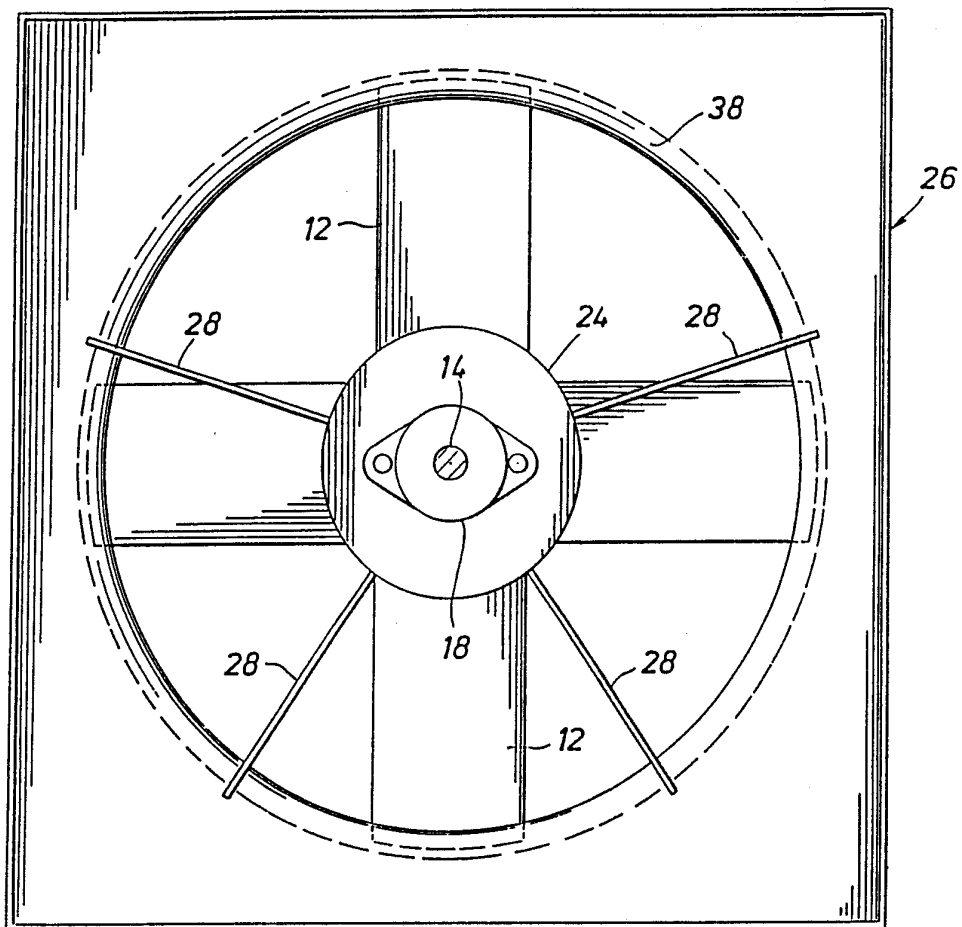

FIG. 3

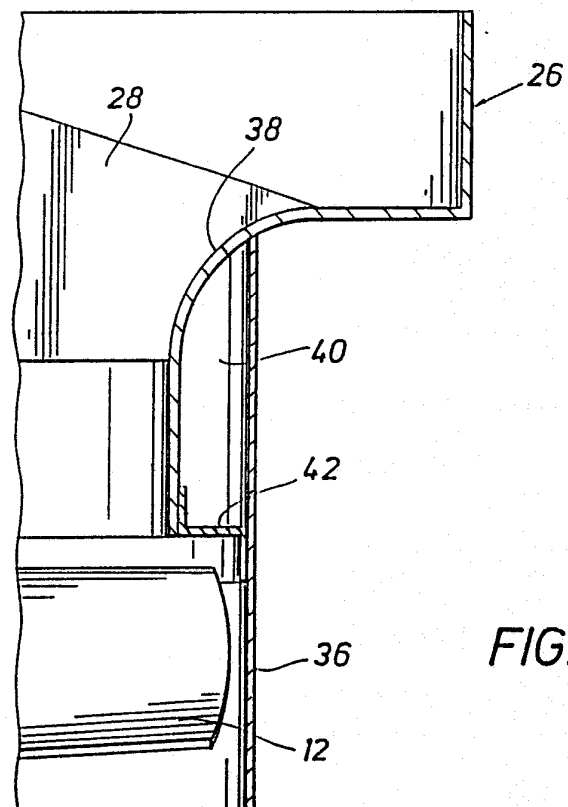
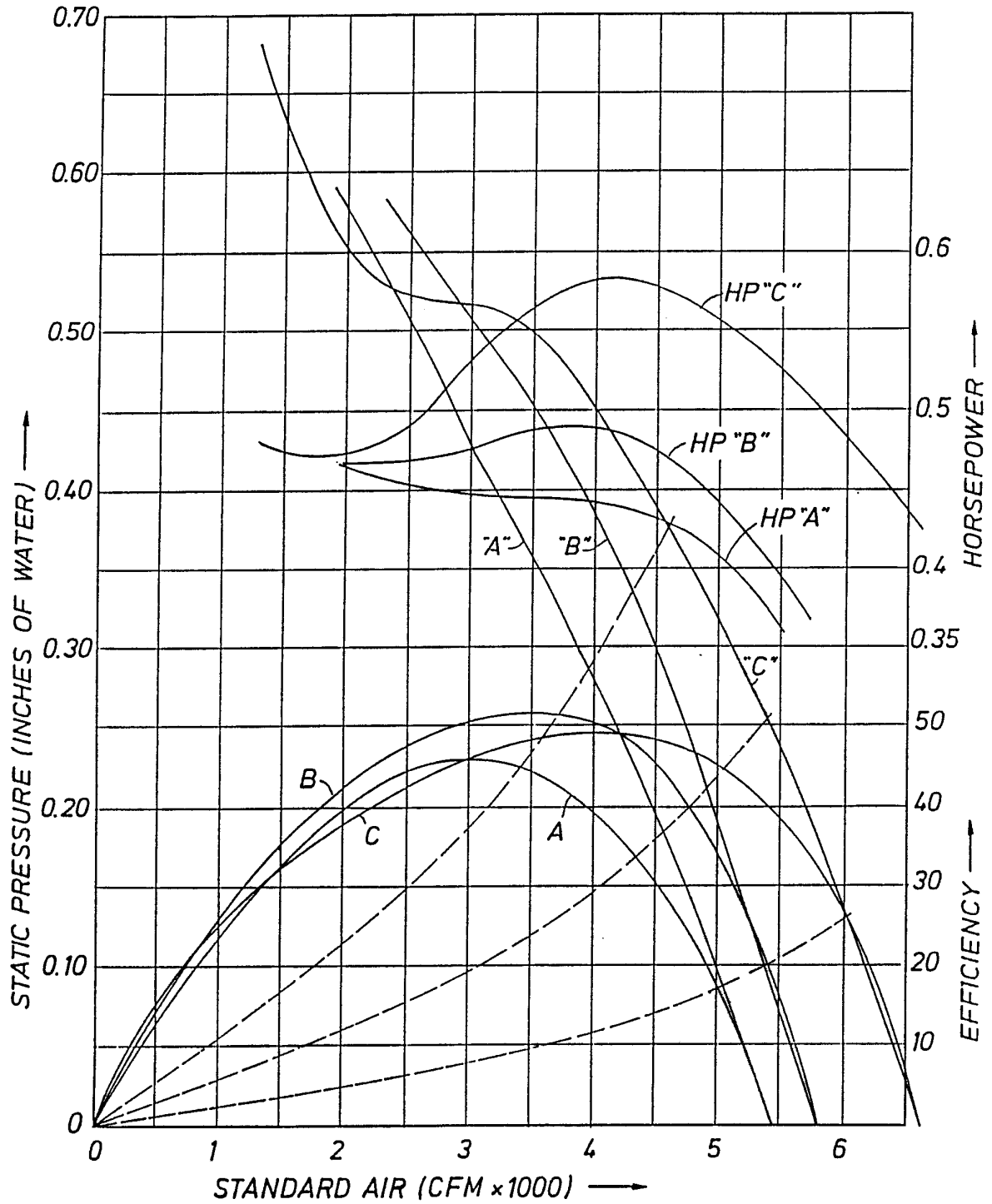

FIG. 4

FIG. 5



INTERNATIONAL SEARCH REPORT

PCT/US 90/02119

International Application No.

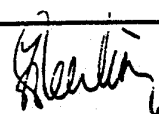
I. CLASSIFICATION OF SUBJECT MATTER (if several classification symbols apply, indicate all) ⁶ According to International Patent Classification (IPC) or to both National Classification and IPC Int.Cl. 5 F04D29/54 ; F04D29/16		
II. FIELDS SEARCHED Minimum Documentation Searched ⁷		
Classification System	Classification Symbols	
Int.Cl. 5	F04D	
Documentation Searched other than Minimum Documentation to the Extent that such Documents are Included in the Fields Searched ⁸		
III. DOCUMENTS CONSIDERED TO BE RELEVANT⁹		
Category ¹⁰	Citation of Document, ¹¹ with indication, where appropriate, of the relevant passages ¹²	Relevant to Claim No. ¹³
A	US,A,1466472 (FALES) 28 August 1923 see the whole document ---	1
A	WO,A,8502889 (GERRY) 4 July 1985 see page 5, line 26 - page 7, line 26; figures 1, 2, 3a ---	1, 2
A	DE,A,1428273 (SIEMENS) 2 January 1969 see page 5, lines 6 - 18; figure 1 ---	1, 2
A	GB,A,355549 (SCHMIDT'SCHE HEISSDAMPFGESELLSCHAFT) 17 September 1931 see the whole document ---	1
A	US,A,4406581 (ROBB) 27 September 1983 (cited in the application) ---	
A	US,A,4515071 (ZACH) 7 May 1985 (cited in the application) ---	
	-/--	
¹⁰ Special categories of cited documents : "A" document defining the general state of the art which is not considered to be of particular relevance "E" earlier document but published on or after the international filing date "L" document which may throw doubts on priority claim(s) or which is cited to establish the publication date of another citation or other special reason (as specified) "O" document referring to an oral disclosure, use, exhibition or other means "P" document published prior to the international filing date but later than the priority date claimed "T" later document published after the international filing date or priority date and not in conflict with the application but cited to understand the principle or theory underlying the invention "X" document of particular relevance; the claimed invention cannot be considered novel or cannot be considered to involve an inventive step "Y" document of particular relevance; the claimed invention cannot be considered to involve an inventive step when the document is combined with one or more other such documents, such combination being obvious to a person skilled in the art. "&" document member of the same patent family		
IV. CERTIFICATION		
Date of the Actual Completion of the International Search	Date of Mailing of this International Search Report	
07 FEBRUARY 1991	28. 02. 91	
International Searching Authority	Signature of Authorized Officer	
EUROPEAN PATENT OFFICE	TEERLING J.H. 	

III. DOCUMENTS CONSIDERED TO BE RELEVANT (CONTINUED FROM THE SECOND SHEET)		
Category °	Citation of Document, with indication, where appropriate, of the relevant passages	Relevant to Claim No.
A	US,A,2030993 (LANGENKAMP) 18 February 1936 (cited in the application) ---	