

Aug. 2, 1938.

A. MARTIN

2,125,733

TIME SWITCH

Filed Nov. 17, 1936

2 Sheets-Sheet 1

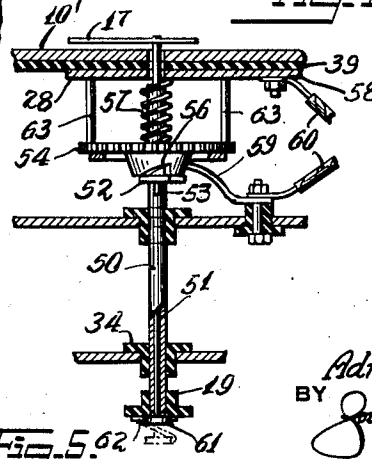
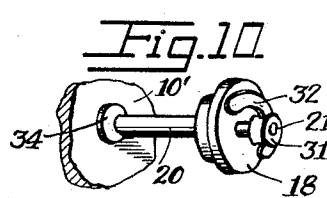
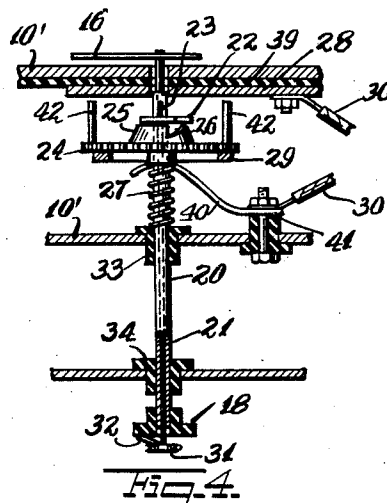
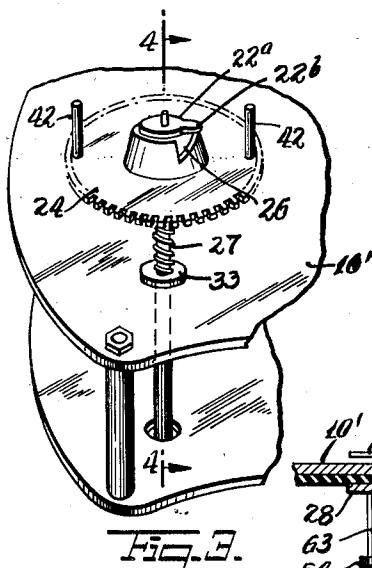
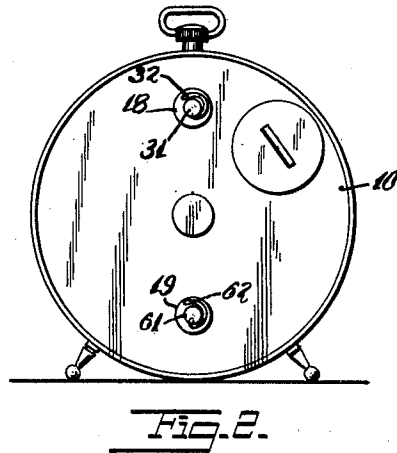
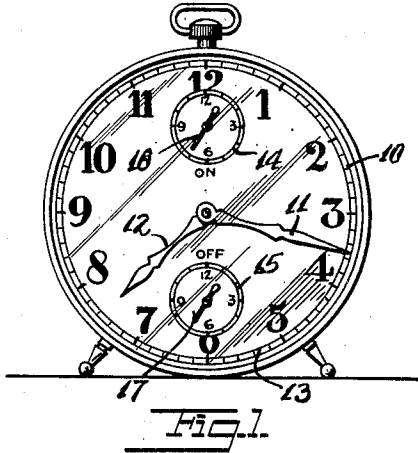

INVENTOR
Adrian Martin
BY *Jules H. Polach*
ATTORNEY

Aug. 2, 1938.

A. MARTIN

2,125,733

TIME SWITCH

Filed Nov. 17, 1936

2 Sheets-Sheet 2

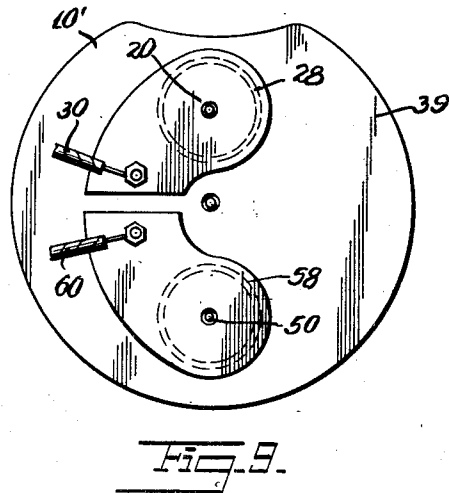
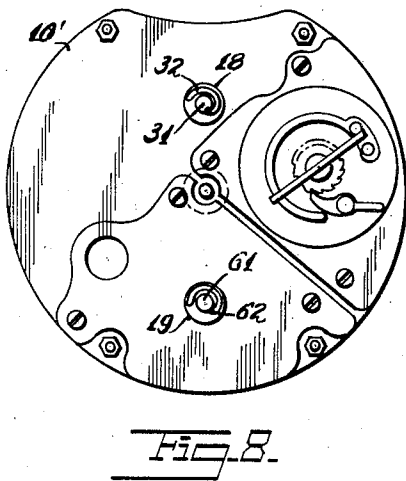
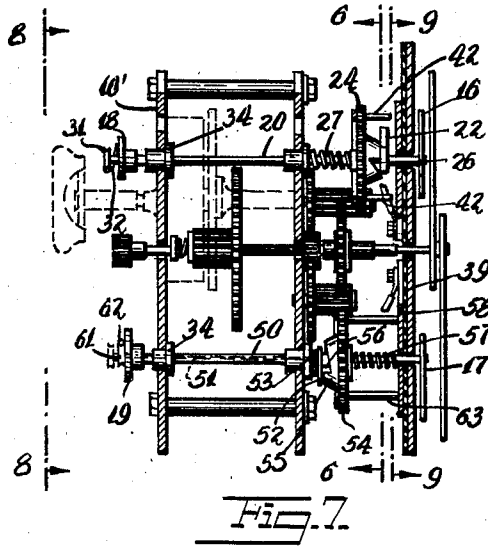
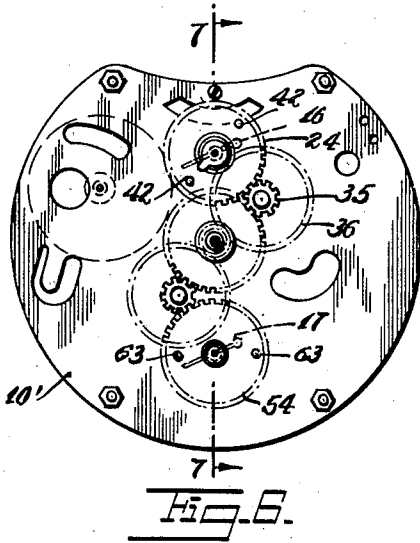

INVENTOR
Adriano Martin
BY *Johann P. Polachek*
ATTORNEY

UNITED STATES PATENT OFFICE

2,125,733

TIME SWITCH

Adrian Martin, New York, N. Y.

Application November 17, 1936, Serial No. 111,192

2 Claims. (Cl. 200—38)

This invention relates to new and useful improvements in a time switch.

The invention has for an object to incorporate in a clock one or more time switches for the purpose of closing or opening, or closing and opening circuits at pre-determined intervals.

More specifically, the invention contemplates to construct one time switch associated with the mechanism of the clock and capable of opening a switch at any pre-determined time as set by an indicator upon the front of the dial. A further object is to construct a switch substantially identical as set forth in this paragraph except to be capable of closing a circuit.

For further comprehension of the invention, and of the objects and advantages thereof, reference will be had to the following description and accompanying drawings, and to the appended claims in which the various novel features of the invention are more particularly set forth.

In the accompanying drawings forming a material part of this disclosure:

Fig. 1 is a front elevational view of a clock with an "on" and an "off" switch incorporated therewith according to this invention.

Fig. 2 is a rear elevational view of Fig. 1.

Fig. 3 is a fragmentary perspective view of a portion of the mechanism of the "on" switch.

Fig. 4 is a fragmentary sectional view taken on the line 4—4 of Fig. 3.

Fig. 5 is a view similar to Fig. 4 but illustrating the "off" switch.

Fig. 6 is a transverse sectional view taken on the line 6—6 of Fig. 7.

Fig. 7 is a sectional view taken on the line 7—7 of Fig. 6.

Fig. 8 is an elevational view looking in the direction of the line 8—8 of Fig. 7.

Fig. 9 is a sectional view taken on the line 9—9 of Fig. 7.

Fig. 10 is a perspective view of a portion of Fig. 7.

The time switch clock comprises a clock 10 of conventional construction having a minute hand 11, an hour hand 12 and a time dial 13. Imprinted on the dial there are additional switch dials, as for example, an "on" switch dial 14 and an "off" switch dial 15. Small hands 16 and 17 respectively indicate on the small dials 14 and 15. These hands may be set from the back of the clock, as shown in Fig. 2, by turning knobs 18 and 19. Thus, the "on" switch may be set to one time, at which time a circuit will be turned on, and the "off" switch may be set to another

time, at which time the same or other circuit may be turned off.

The "on" switch includes a switch spindle 20 insulated from and rotative through the frame 10' of the clock and projecting from the face side of the clock and from the back side. The hand 16 is mounted upon the face side of the spindle 20. The knob 18 is mounted on the back side of the spindle. A rod 21 slidably engages through the spindle 20 and projects from the back side end. A lug 22 is slidable upon the said spindle 20 and is connected through a slot 23 in the spindle with the said rod 21. An insulated gear 24 is rotative on the spindle 20 and has a hub portion 25 with a cam cutout 26 cooperative with the said lug 22 to permit the gear to slide on the spindle when the cutout and lug are in line.

A resilient means 27 is provided for urging the gear 24 to slide towards the lug 22 when the lug and cutout are in line. A stationary contact 28, and a contact 29 mounted upon the gear 24 are adapted to indirectly coast when the gear 24 slides as before mentioned. These contacts are arranged in a circuit 30. A head 31 is mounted on the extended end of the rod 21 and is engaged by a releasable means 32 mounted on the knob 18 to hold the rod 21 fixed in said spindle until the gear slides, and then by impact to release the rod whereby the lug 22 then becomes inoperative and engages the cutout permitting the gear 24 to slide thereto and so indirectly cause the co-action between the contacts 28 and 29.

The spindle 20 is rotative through insulation bushings 33 and 34 mounted on the frame 10' of the clock. The knob 18 preferably should be constructed of insulation material. The gear 24 is in mesh with a pinion 35 of insulation material. This pinion is connected with a train of gears 36 connected with the time mechanism of the clock. Thus the gear 24 is rotated by the mechanism of the clock, though insulated from it. The lug 22 has a hub portion 22^a which is coaxial on the rod 20 and a projecting portion 22^b. It is this projecting portion that is capable of engaging in the cam cutout 26 (see particularly Fig. 3). The resilient means 27 consists of a spring coaxial upon the spindle 20 and acting between the insulating bushing 33 and the gear 24.

The stationary contact 28 is mounted on an insulation plate 39 which in turn is mounted upon the frame 10' of the clock. The contact 29 is of annular form and mounted concentric with the spindle 20 on the gear 24. A conductor finger 40 engages this contact 29 and is mounted upon a

terminal 41 which is connected in the circuit 30. The releasable means 32 comprises a flat spring attached at one end upon the knob 18 and extending around the head 31 and terminating in an end engaging a grooved side of the head. This spring 32 is capable of holding the lug 22 stationary relative to the spindle 20 until it is disconnected due to shock when the gear 24 suddenly slides on the spindle 20 (see Fig. 11). There are several pins 42 projecting from one face of the gear 24 and adapted to engage the contact 28 when the gear 24 is permitted to slide.

The operation of the "on" switch is as follows:

The knob 18 may be turned manually to turn the spindle 20 and the hand 16 to a desired position upon the dial 14. For example, the handle may turn to 8 o'clock. Since the lug 22 extends through the slot 23 and is connected with the rod 21 it will turn along with the spindle, and so will the rod. The clock mechanism is continuously turning the gear 24 and when the pre-determined time is reached the cutout 26 reaches the lug portion 22^b and the spring 27 snaps the gear 24 forwards as permitted by the inter-engagement of the cutout 26 and the lug. The impact of the gear 24 striking the lug 22 is sufficient to release the head 31 from the holding means 32. The clock mechanism continues to operate and soon the cutout 26 of the gear 24 rides out from the lug 22^b, but it is not moved rearwards to break the connection between the pins 42 and the contact 28 because now the lug 22 is no longer held in its fixed position but is free, as the rod 21 is free. In order to re-set the time switch it is necessary that the head 31 be manually pulled outwards and the holding means 32 be allowed to engage the periphery of the head and hold it in the extended position.

The "off" switch is substantially identical to the construction of the "on" switch but is so arranged that initially the circuit is closed, and at a predetermined time the circuit is open. According to this form of the invention there is a switch spindle 50 insulated from and rotative through the frame 10' and projecting from the face side of the clock and from the back side of the clock. The hand 17 is attached on the face side of the support and indicates on the dial 15. The knob 19 is attached upon the back side of the spindle. A rod 51 is slidable through the spindle 50 and projects from the back side. A plug 52 is slidable on the spindle 50 and is connected through a slot 43 in the spindle with the rod 51.

An insulated gear 54 is rotative on the spindle 50 and has a hub portion 55 with a cam cutout 56 cooperative with the lug 52 to permit the gear to slide on the spindle when the cutout and lug are in line. A resilient means in the form of a spring 57 is arranged on the spindle 50 and acts between the insulation plate 39 and the gear 54 to urge the gear against the lug 52. There is a stationary contact 58 and a contact 59 on the gear 54. These contacts are adapted to coast when the gears slide. They are associated with a circuit 60.

A head 61 is mounted on the extended end of the rod 51. A releasable means 62 coacts with the said head 61 to hold the rod fixed on said spindle until the gear slides, and then by impact releasing

said rod whereby said lug then becomes inoperative to control the gear and indirectly the said circuit. The gear 54 is provided with several pins 63 which normally engage the contact 58. The spring 57 is urging the gear 54 away from the contact 58 but is restrained by the lug 52 until the cutout 56 is reached, and then the gear 54 slides breaking the circuit between the pins 63 and the contact 58. The impact of the gear striking the lug 52 moves the lug and the rod 51 and frees the head 61 from the holding means 62. The circuit now remains open even though the gear 54 rotates so that the lug 52 is out from the cutout 56.

While I have illustrated and described the preferred embodiments of my invention, it is to be understood that I do not limit myself to the precise constructions herein disclosed and the right is reserved to all changes and modifications coming within the scope of the invention as defined in the appended claims.

Having thus described my invention, what I claim as new, and desire to secure by United States Letters Patent, is:

1. In combination with a clock, a switch spindle insulated from and rotative through the frame of said clock and projecting from the face side of the clock and from the back side, a knob on the back side of said spindle by which it may be manually adjusted, a rod slidable through said spindle and projecting from the back side end, a lug slidable on said spindle and connected through a slot in said spindle with said rod, an insulated gear rotative on said spindle and having a hub with a cam cutout cooperative with said lug to permit the gear to slide on said spindle when the cutout and lug are in line, resilient means for urging said gear to slide when said lug and cutout are in line to operate a circuit, a head on the extended end of said rod, and releasable means coacting with said head to hold the rod in said spindle until the gear slides and then by impact releasing said rod whereby said lug becomes inoperative to control said gear and so indirectly said circuit.

2. In combination with a clock, a switch spindle insulated from and rotative through the frame of said clock and projecting from the face side of the clock and from the back side, a knob on the back side of said spindle by which it may be manually adjusted, a rod slidable through said spindle and projecting from the back side end, a lug slidable on said spindle and connected through a slot in said spindle with said rod, an insulated gear rotative on said spindle and having a hub with a cam cutout cooperative with said lug to permit the gear to slide on said spindle when the cutout and lug are in line, resilient means for urging said gear to slide when said lug and cutout are in line to operate a circuit, a head on the extended end of said rod, and releasable means coacting with said head to hold the rod in said spindle until the gear slides and then by impact releasing said rod whereby said lug becomes inoperative to control said gear and so indirectly said circuit, said releasable means comprising a spring mounted on said knob and extended annularly around said head and engaging in a groove in the side of the head.

ADRIAN MARTIN.