



US00D793307S

(12) **United States Design Patent**
Wen

(10) **Patent No.:** **US D793,307 S**

(45) **Date of Patent:** **** Aug. 1, 2017**

(54) **BRAKE BACKING PLATE WITH HEAT SINK**

(71) Applicant: **Yuan-Hung Wen**, Chang Hua County (TW)

(72) Inventor: **Yuan-Hung Wen**, Chang Hua County (TW)

(**) Term: **15 Years**

(21) Appl. No.: **29/533,449**

(22) Filed: **Jul. 17, 2015**

(30) **Foreign Application Priority Data**

Mar. 17, 2015 (TW) 104301364

(51) **LOC (10) Cl.** **12-16**

(52) **U.S. Cl.**
USPC **D12/180**

(58) **Field of Classification Search**

USPC D12/14, 106, 114, 118, 122, 161, 162, D12/179, 180, 207, 217, 400
CPC ... B60T 1/06; B60T 7/00; B60T 8/265; B60T 11/00; B60T 11/103; B60T 13/00; B60T 13/66; B60T 17/223; B60T 83/255; B60T 2201/00; B60T 2201/03; B60T 2260/00; B60T 2270/00; B60T 2270/82; B60T 2270/83; B60T 2270/84; B62K 23/06; B62L 1/02; B62L 3/02; B62D 13/025; B62D 21/18; B62D 53/045; B62D 63/04; B62D 65/02; B62D 65/18; F16D 55/00; F16D 55/226; F16D 65/00; F16D 65/092; F16D 65/095; F16D 65/097; F16D 65/18; F16D 65/38; F16D 65/847; B32B 3/06

See application file for complete search history.

(56) **References Cited**

U.S. PATENT DOCUMENTS

1,344,498 A * 6/1920 Fox B43L 3/008
281/32
1,415,837 A * 5/1922 Green A47C 21/022
5/405

1,526,578 A * 2/1925 Young B65D 19/0002
34/238
1,670,228 A * 5/1928 Arrowsmith B42D 19/00
281/12
1,722,551 A * 7/1929 Zadek B62B 9/102
24/710.3
1,734,275 A * 11/1929 Simpson B60C 23/063
116/34 A
1,866,691 A * 7/1932 Worley, Jr. D06F 81/14
24/562
1,892,350 A * 12/1932 Kestenman A44C 5/145
224/177
1,894,012 A * 1/1933 Wenlinger E02D 5/04
405/276
1,914,951 A * 6/1933 Kiessling A47G 1/162
248/498
2,049,436 A * 8/1936 Gollwitzer B41L 47/02
101/369
2,055,541 A * 9/1936 Kestenman A44C 5/02
59/80
2,107,743 A * 2/1938 Shoup G03B 31/02
226/196.1
2,121,452 A * 6/1938 Soss E05D 3/145
16/370
2,121,912 A * 6/1938 Glover A47L 13/46
15/120.1
2,189,861 A * 2/1940 Hallett E01C 11/12
404/47
2,433,760 A * 12/1947 Janes B25B 27/0021
100/300
2,515,818 A * 7/1950 Bennett G09F 7/00
40/607.06
2,541,632 A * 2/1951 Baugh B65G 17/08
198/850
2,587,912 A * 3/1952 Simpson A47K 1/08
248/221.11
2,639,526 A * 5/1953 Beprestis B42F 5/005
211/46
2,660,906 A * 12/1953 French B62D 7/16
280/93.508
2,669,502 A * 2/1954 Walmsley D06B 3/10
28/165
2,684,400 A * 7/1954 Redmond H02G 3/083
174/153 G
2,696,689 A * 12/1954 Speck A44C 5/18
24/265 WS
2,770,980 A * 11/1956 Millward B62K 23/06
74/489
2,857,596 A * 10/1958 Allen B25C 1/04
227/123

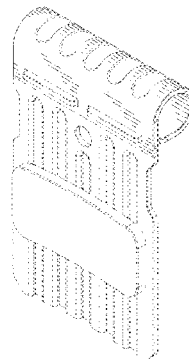
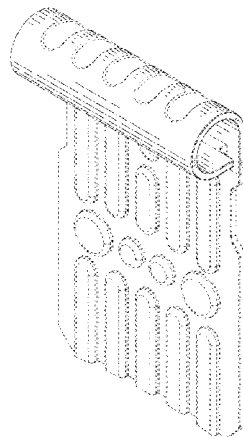

US D793,307 S

2,929,093 A *	3/1960	Conlee	E05D 11/06 16/338	6,918,466 B1 *	7/2005	Decker, Jr.	B60T 7/04 188/3 R
2,954,622 A *	10/1960	Moore	A44C 5/0015 40/662	7,219,773 B2 *	5/2007	Ono	F16D 65/0971 188/250 E
D192,757 S *	5/1962	Foss et al.	D21/390	D545,253 S *	6/2007	Jones	D12/106
3,070,234 A *	12/1962	Deitchman	A47B 57/40 108/107	7,267,208 B2 *	9/2007	Jedele	F16D 65/0977 188/73.38
3,087,214 A *	4/1963	Puterbaugh	B60R 13/105 24/300	7,308,974 B2 *	12/2007	Barbosa	F16D 65/095 188/72.3
3,209,710 A *	10/1965	Hines	A47B 61/00 108/30	7,318,568 B2 *	1/2008	Barouta	B65D 33/001 206/554
3,277,985 A *	10/1966	Caskey	F16D 65/092 188/250 B	7,547,234 B2 *	6/2009	Wallace	G06K 19/07732 235/441
3,380,419 A *	4/1968	Moloney	B21D 51/44 215/247	D601,412 S *	10/2009	Brown	D8/395
3,446,381 A *	5/1969	Vignati	B65D 51/145 215/333	D606,848 S *	12/2009	Jimenez	D8/395
3,592,297 A *	7/1971	Leffert	F16D 65/84 188/250 B	7,631,733 B2 *	12/2009	Roberts	F16D 55/226 188/73.1
3,662,593 A *	5/1972	Pirrello	B60T 17/223 254/DIG. 5	D608,190 S *	1/2010	Jimenez	D8/395
3,836,033 A *	9/1974	Podesta	B65D 51/145 215/276	D610,901 S *	3/2010	Jones	D8/394
4,006,616 A *	2/1977	Rubner	E05B 17/181 70/455	D615,497 S *	5/2010	Woodward	D13/149
4,090,004 A *	5/1978	Tebbutt	B21D 51/38 220/804	D621,331 S *	8/2010	Bock	D12/345
4,333,550 A *	6/1982	Shirai	F16D 55/22 188/72.2	D626,055 S *	10/2010	Watson	D12/218
4,507,368 A *	3/1985	Hashimoto	H01M 2/105 429/62	7,832,249 B2 *	11/2010	Schumann	B65D 83/62 413/5
4,571,920 A *	2/1986	Roach	B67B 3/22 53/300	D643,351 S *	8/2011	Arbesman	D12/180
4,723,676 A *	2/1988	Kobayashi	B65D 43/0222 215/301	D656,811 S *	4/2012	Giordano	D8/349
4,730,710 A *	3/1988	Granitz	F16D 67/02 192/18 R	8,413,771 B2 *	4/2013	Teagan	F16D 55/225 188/264 A
4,747,793 A *	5/1988	Fukuda	H01R 11/287 439/754	D685,304 S *	7/2013	Moore	D12/180
4,844,546 A *	7/1989	Hanai	B60N 2/46 297/218.1	D691,027 S *	10/2013	Rainer	D8/356
4,918,786 A *	4/1990	Perry	B64C 9/02 16/365	D691,071 S *	10/2013	Deng	D12/125
D311,484 S *	10/1990	Sachs	D8/367	8,550,220 B2 *	10/2013	Iwai	F16D 65/092 188/218 XL
D315,289 S *	3/1991	Rankin	D8/373	8,732,908 B2 *	5/2014	Hatano	E05D 11/082 16/342
5,141,192 A *	8/1992	Adams	F21S 4/10 248/229.26	D713,282 S *	9/2014	Finnegan	D11/3
D330,850 S *	11/1992	Roick	D8/367	D714,852 S *	10/2014	Levesque	D16/237
5,184,792 A *	2/1993	Bernhard	H02G 3/26 248/71	8,899,091 B2 *	12/2014	Ramsey	B21D 51/44 413/8
5,325,737 A *	7/1994	Bendetti	B62K 21/26 74/551.9	9,033,731 B2 *	5/2015	Malek	H01R 9/0524 439/101
D349,641 S *	8/1994	Moliner	D8/367	D741,780 S *	10/2015	Lee	D12/415
5,351,974 A *	10/1994	Cech	B60T 1/04 188/17	2002/0197448 A1 *	12/2002	Booher	B29C 70/24 428/113
5,639,049 A *	6/1997	Jennings	F16L 3/123 24/563	2003/0024983 A1 *	2/2003	Yeh	G06K 7/0082 235/441
5,681,191 A *	10/1997	Robicheau	H01R 4/184 439/877	2003/0089414 A1 *	5/2003	Ooyouchi	B21C 37/06 138/171
5,782,583 A *	7/1998	Vales	E02D 5/04 405/281	2004/0016758 A1 *	1/2004	Richardson	B65D 51/145 220/288
6,058,580 A *	5/2000	Shih	A47G 25/483 24/501	2004/0031710 A1 *	2/2004	K	B65D 25/282 206/378
D426,425 S *	6/2000	Hermanski	D7/213	2007/0158618 A1 *	7/2007	Song	B82Y 30/00 252/500
D427,051 S *	6/2000	Lodi	D8/395	2010/0051393 A1 *	3/2010	Arioka	F16D 65/0972 188/72.3
6,095,294 A *	8/2000	McGourthy, Sr.	B60T 7/14 188/166	2011/0011866 A1 *	1/2011	Dunwoody	B65D 41/02 220/310.1
6,182,933 B1 *	2/2001	Rapp	E04D 13/00 248/231.31	2012/0111010 A1 *	5/2012	Geldon	F03G 7/00 60/721
6,419,601 B1 *	7/2002	Kenner	A63B 49/08 16/430	2012/0138398 A1 *	6/2012	Nadal Aloy	F16D 65/12 188/218 XL
D481,303 S *	10/2003	Fell	D26/138	2013/0139718 A1 *	6/2013	Taguchi	B61D 25/00 105/329.1
D481,659 S *	11/2003	Reimann	D12/180	2013/0240306 A1 *	9/2013	Murphy	F16D 65/0006 188/73.37
6,644,836 B1 *	11/2003	Adams	F21V 21/08 362/145	2014/0151168 A1 *	6/2014	Wen	F16D 65/092 188/251 R
				2015/0090538 A1 *	4/2015	Moore	F16D 66/02 188/1.11 W
				2015/0090543 A1 *	4/2015	Moore	F16D 65/092 188/250 G
				2015/0176669 A1 *	6/2015	Wen	F16D 65/092 188/250 B

2015/0211590 A1* 7/2015 Tseng F16D 65/092
 188/250 B
 2016/0160950 A1* 6/2016 Wen F16D 65/092
 188/264 R
 2016/0208872 A1* 7/2016 Morio F16D 65/18

(74) *Attorney, Agent, or Firm* — Muncy, Geissler, Olds & Lowe, P.C.

(57) **CLAIM**

I claim the ornamental design for a brake backing plate with heat sink, as shown and described.

OTHER PUBLICATIONS

Curled edge sheet metal, image post date Mar. 23, 2013, site visited Dec. 24, 2016, (online), <http://toolengonblog.blogspot.com/2013_03_01_archive.html>.*

Brake lining, image post date 2009, site visited Dec. 24, 2016, (online), <http://www.brici.org/P_view.asp?pid=43>.*

Nissan Sentra front brake pads diagram, image post date 2011, site visited Dec. 24, 2016, (online), <<http://www.justanswer.com/nissan/5pj48-nissan-datsun-sentra-purchased-new-front-brake-pads.html>>.*

Posi Quiet brake pads, image post date Dec. 14, 2013, site visited Dec. 17, 2016, (online), <<https://www.fineye.com/search/0f86bd2d97e7f6a6967a6fbd86ded19cda42092e/>>.*

* cited by examiner

Primary Examiner — Kevin Rudzinski

Assistant Examiner — Sean D Lough

DESCRIPTION

FIG. 1 is a perspective view of a brake backing plate with heat sink showing my new design;

FIG. 2 is a front elevational view thereof;

FIG. 3 is a rear elevational view thereof;

FIG. 4 is a left side view thereof, the right being a mirror image;

FIG. 5 is a top plan view thereof;

FIG. 6 is a bottom plan view thereof; and,

FIG. 7 is a perspective view showing the brake backing plate with heat sink in use with additional environment shown in broken lines.

The broken lines in the drawings illustrate portions of the brake backing plate with heat sink which form no part of the claimed design.

1 Claim, 6 Drawing Sheets

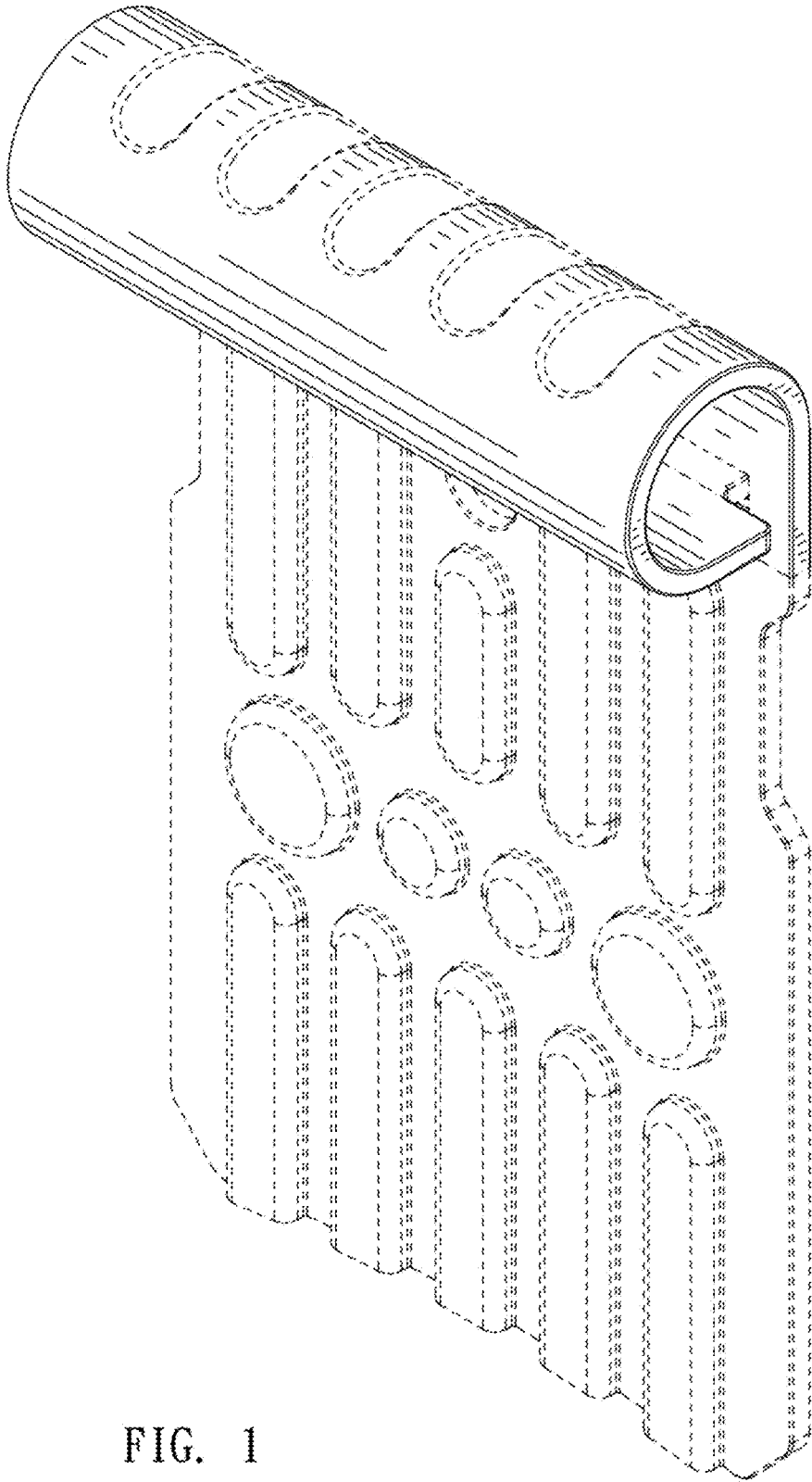

FIG. 1

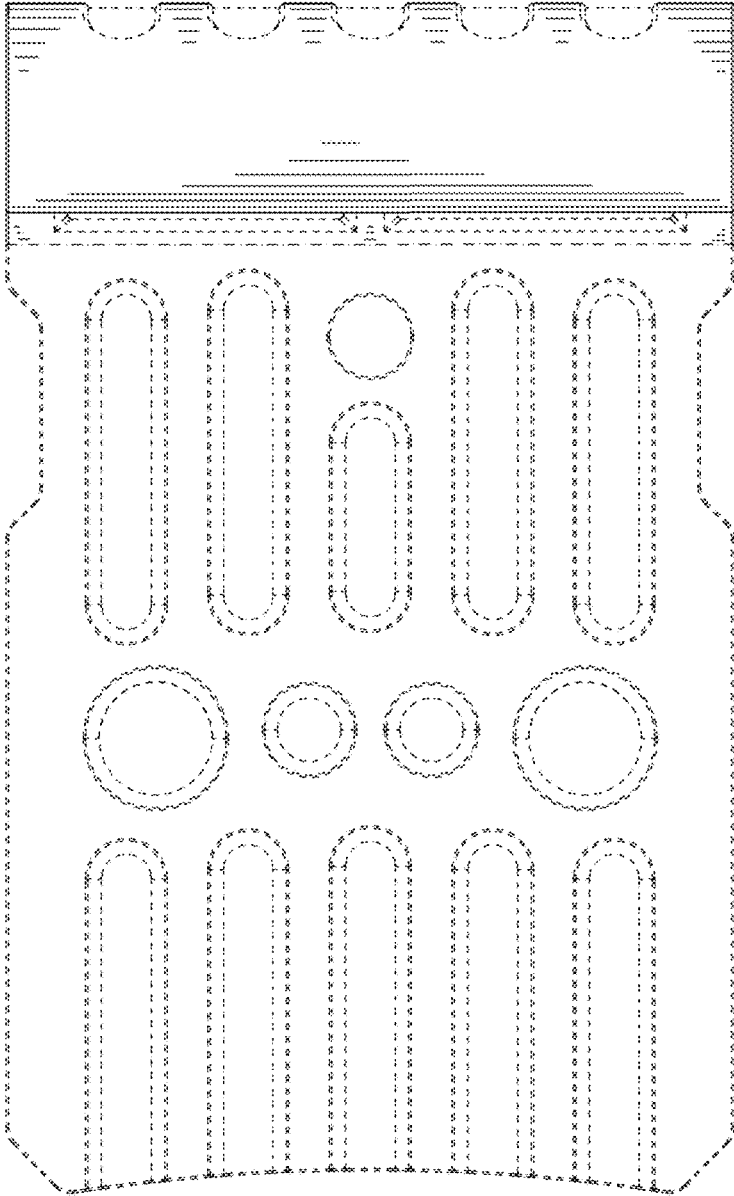

FIG. 2

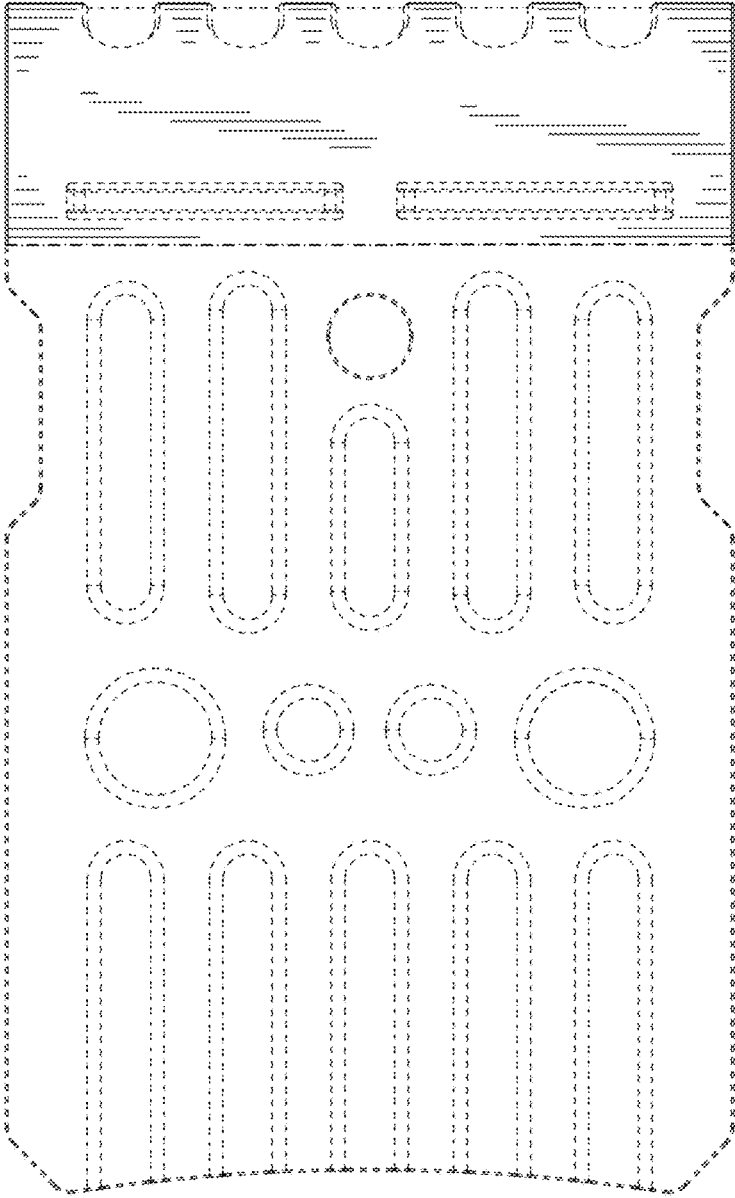

FIG. 3

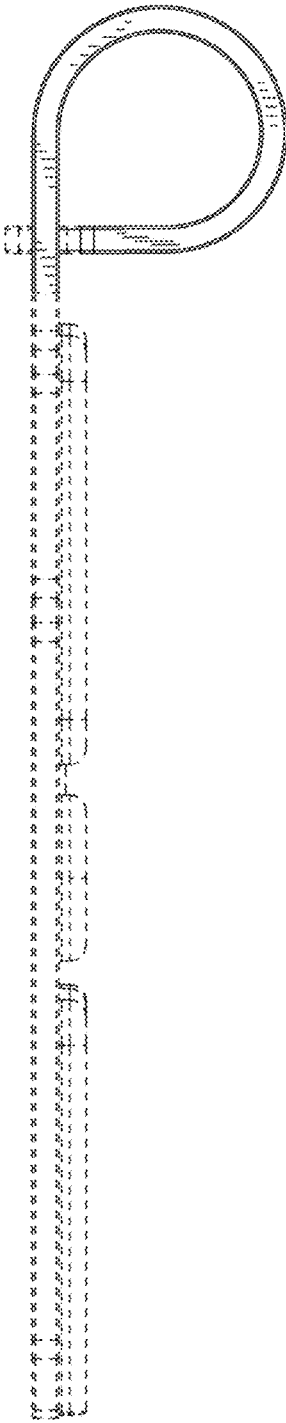

FIG. 4

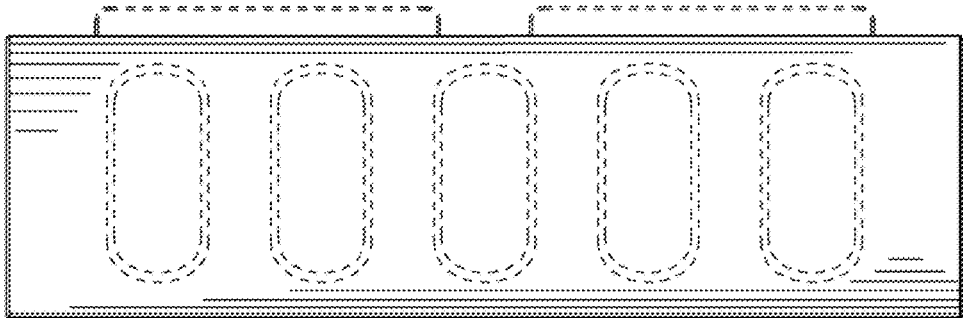

FIG. 5

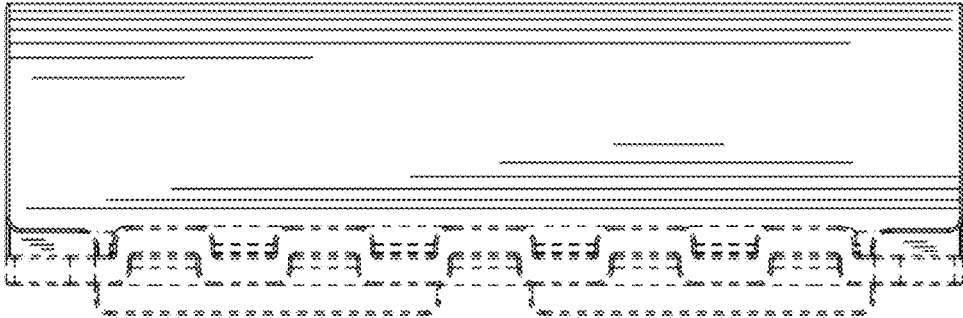

FIG. 6

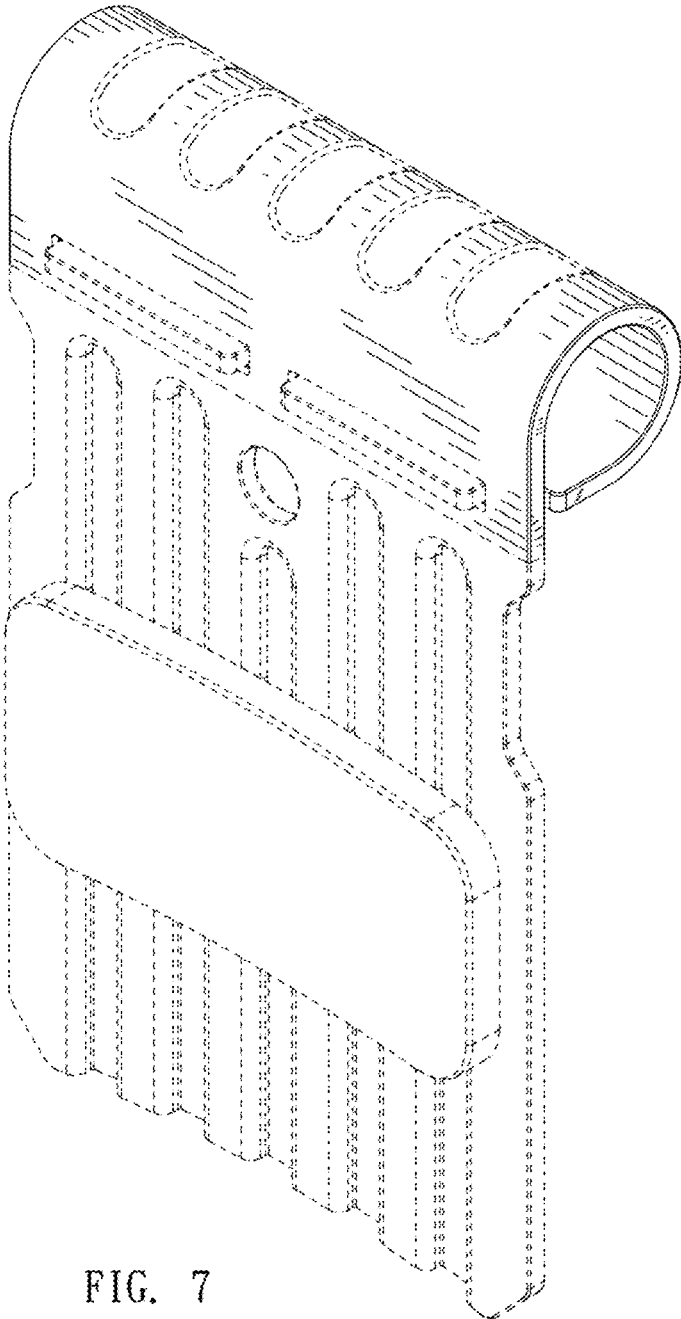

FIG. 7