



INTERNATIONAL APPLICATION PUBLISHED UNDER THE PATENT COOPERATION TREATY (PCT)

<p>(51) International Patent Classification ⁶ : G01N 27/327, C12Q 1/00</p>	A1	<p>(11) International Publication Number: WO 98/35225</p> <p>(43) International Publication Date: 13 August 1998 (13.08.98)</p>
<p>(21) International Application Number: PCT/US98/02652</p> <p>(22) International Filing Date: 6 February 1998 (06.02.98)</p> <p>(30) Priority Data: 08/795,767 6 February 1997 (06.02.97) US</p> <p>(63) Related by Continuation (CON) or Continuation-in-Part (CIP) to Earlier Application US 08/795,767 (CIP) Filed on 6 February 1997 (06.02.97)</p> <p>(71) Applicant (for all designated States except US): E. HELLER & COMPANY [US/US]; Suite 1000, 1311 Harbor Bay Parkway, Alameda, CA 94502 (US).</p> <p>(72) Inventors; and (75) Inventors/Applicants (for US only): HELLER, Adam [US/US]; 5317 Valburn Circle, Austin, TX 78731 (US). FELDMAN, Benjamin, J. [US/US]; 5830 Colby Street, Oakland, CA 94618 (US). SAY, James [US/US]; 460 Cola Ballena #A, Alameda, CA 94501 (US). VREEKE, Mark, S. [US/US]; 2826 Calhoun Street, Alameda, CA 94501 (US). TOMASCO, Michael, F. [US/US]; 22528 Poppy Drive, Cupertino, CA 95014 (US).</p>	<p>(74) Agent: BRUESS, Steven, C.; Merchant, Gould, Smith, Edell, Welter & Schmidt, P.A., 3100 Norwest Center, 90 South Seventh Street, Minneapolis, MN 55402-4131 (US).</p> <p>(81) Designated States: AL, AM, AT, AT (Utility model), AU, AZ, BA, BB, BG, BR, BY, CA, CH, CN, CU, CZ, CZ (Utility model), DE, DE (Utility model), DK, DK (Utility model), EE, EE (Utility model), ES, FI, FI (Utility model), GB, GE, GH, GM, GW, HU, ID, IL, IS, JP, KE, KG, KP, KR, KZ, LC, LK, LR, LS, LT, LU, LV, MD, MG, MK, MN, MW, MX, NO, NZ, PL, PT, RO, RU, SD, SE, SG, SI, SK, SK (Utility model), SL, TJ, TM, TR, TT, UA, UG, US, UZ, VN, YU, ZW, ARIPO patent (GH, GM, KE, LS, MW, SD, SZ, UG, ZW), Eurasian patent (AM, AZ, BY, KG, KZ, MD, RU, TJ, TM), European patent (AT, BE, CH, DE, DK, ES, FI, FR, GB, GR, IE, IT, LU, MC, NL, PT, SE), OAPI patent (BF, BJ, CF, CG, CI, CM, GA, GN, ML, MR, NE, SN, TD, TG).</p> <p>Published With international search report. Before the expiration of the time limit for amending the claims and to be republished in the event of the receipt of amendments.</p>	

(54) Title: SMALL VOLUME *IN VITRO* ANALYTE SENSOR

(57) Abstract

A sensor designed to determine the amount and concentration of analyte in a sample having a volume of less than about 1 μ L. The sensor has a working electrode coated with a non-leachable redox mediator. The redox mediator acts as an electron transfer agent between the analyte and the electrode. In addition, a second electron transfer agent, such as an enzyme, can be added to facilitate the electrooxidation or electroreduction of the analyte. The redox mediator is typically a redox compound bound to a polymer. The preferred redox mediators are airoxidizable. The amount of analyte can be determined by coulometry. One particular coulometric technique includes the measurement of the current between the working electrode and a counter or reference electrode at two or more times. The charge passed by this current to or from the analyte is correlated with the amount of analyte in the sample. Other electrochemical detection methods, such as amperometric, voltammetric, and potentiometric techniques, can also be used. The invention can be used to determine the concentration of a biomolecule, such as glucose or lactate, in a biological fluid, such as blood or serum. An enzyme capable of catalyzing the electrooxidation or electroreduction of the biomolecule is provided as a second electron transfer agent.

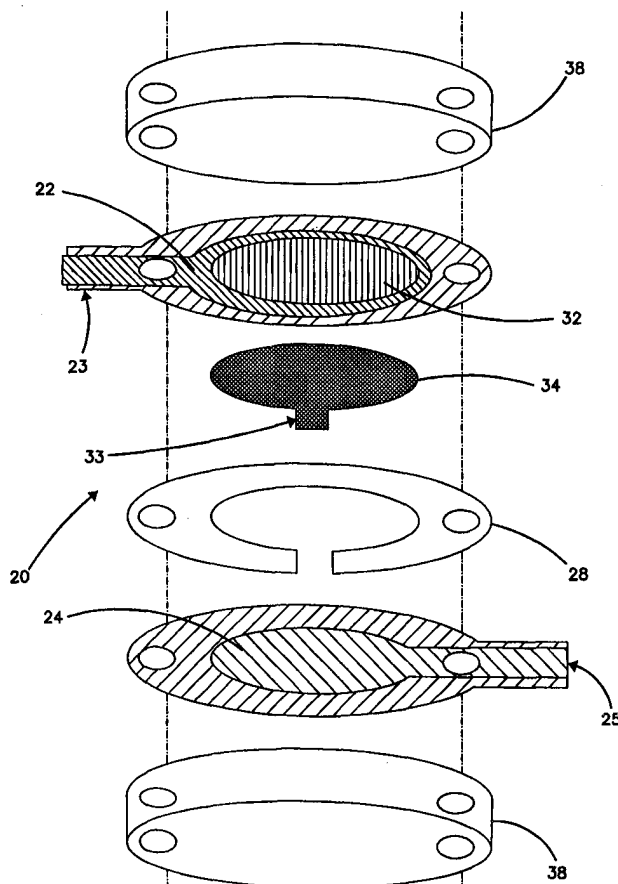

FOR THE PURPOSES OF INFORMATION ONLY

Codes used to identify States party to the PCT on the front pages of pamphlets publishing international applications under the PCT.

AL	Albania	ES	Spain	LS	Lesotho	SI	Slovenia
AM	Armenia	FI	Finland	LT	Lithuania	SK	Slovakia
AT	Austria	FR	France	LU	Luxembourg	SN	Senegal
AU	Australia	GA	Gabon	LV	Latvia	SZ	Swaziland
AZ	Azerbaijan	GB	United Kingdom	MC	Monaco	TD	Chad
BA	Bosnia and Herzegovina	GE	Georgia	MD	Republic of Moldova	TG	Togo
BB	Barbados	GH	Ghana	MG	Madagascar	TJ	Tajikistan
BE	Belgium	GN	Guinea	MK	The former Yugoslav Republic of Macedonia	TM	Turkmenistan
BF	Burkina Faso	GR	Greece			TR	Turkey
BG	Bulgaria	HU	Hungary	ML	Mali	TT	Trinidad and Tobago
BJ	Benin	IE	Ireland	MN	Mongolia	UA	Ukraine
BR	Brazil	IL	Israel	MR	Mauritania	UG	Uganda
BY	Belarus	IS	Iceland	MW	Malawi	US	United States of America
CA	Canada	IT	Italy	MX	Mexico	UZ	Uzbekistan
CF	Central African Republic	JP	Japan	NE	Niger	VN	Viet Nam
CG	Congo	KE	Kenya	NL	Netherlands	YU	Yugoslavia
CH	Switzerland	KG	Kyrgyzstan	NO	Norway	ZW	Zimbabwe
CI	Côte d'Ivoire	KP	Democratic People's Republic of Korea	NZ	New Zealand		
CM	Cameroon		Republic of Korea	PL	Poland		
CN	China	KR	Republic of Korea	PT	Portugal		
CU	Cuba	KZ	Kazakstan	RO	Romania		
CZ	Czech Republic	LC	Saint Lucia	RU	Russian Federation		
DE	Germany	LI	Liechtenstein	SD	Sudan		
DK	Denmark	LK	Sri Lanka	SE	Sweden		
EE	Estonia	LR	Liberia	SG	Singapore		

Small Volume *in vitro* Analyte Sensor

Field of the Invention

This invention relates to analytical sensors for the detection of
5 bioanalytes in a small volume sample.

Background of the Invention

Analytical sensors are useful in chemistry and medicine to determine
the presence and concentration of a biological analyte. Such sensors are needed, for
example, to monitor glucose in diabetic patients and lactate during critical care
10 events.

Currently available technology measures bioanalytes in relatively
large sample volumes, e.g., generally requiring 3 microliters or more of blood or
other biological fluid. These fluid samples are obtained from a patient, for example,
using a needle and syringe, or by lancing a portion of the skin such as the fingertip
15 and "milking" the area to obtain a useful sample volume. These procedures are
inconvenient for the patient, and often painful, particularly when frequent samples
are required. Less painful methods for obtaining a sample are known such as
lancing the arm or thigh, which have a lower nerve ending density. However,
lancing the body in the preferred regions typically produces submicroliter samples of
20 blood, because these regions are not heavily supplied with near-surface capillary
vessels.

It would therefore be desirable and very useful to develop a relatively
painless, easy to use blood analyte sensor, capable of performing an accurate and
sensitive analysis of the concentration of analytes in a small volume of sample.

Summary of the Invention

The sensors of the present invention provide a method for the
detection and quantification of an analyte in submicroliter samples. In general, the
invention includes a method and sensor for analysis of an analyte in a small volume
of sample, preferably by coulometry. A biosensor of the invention utilizes a non-
30 leachable redox mediator, preferably an air-oxidizable redox mediator, and

preferably immobilized on a working electrode. The biosensor also includes a sample chamber to hold the sample in electrolytic contact with the working electrode. In a preferred embodiment, the working electrode faces a counter electrode, forming a measurement zone within the sample chamber, between the two electrodes, that is sized to contain less than about 1 μL of sample, preferably less than about 0.5 μL , more preferably less than about 0.2 μL , and most preferably less than about 0.1 μL of sample. A sorbent material is optionally positioned in the sample chamber and measurement zone to reduce the volume of sample needed to fill the sample chamber and measurement zone.

In one embodiment of the invention, a biosensor is provided which combines the efficiency of coulometric electrochemical sensing with a non-leachable redox mediator to accurately and efficiently measure a bioanalyte in a submicroliter volume of sample. The preferred sensor includes an electrode, a non-leachable redox mediator on the electrode, a sample chamber for holding the sample in electrical contact with the electrode and, preferably, sorbent material disposed within the sample chamber to reduce the volume of the chamber. The sample chamber, together with any sorbent material, is sized to provide for analysis of a sample volume that is typically less than about 1 μL , preferably less than about 0.5 μL , more preferably less than about 0.2 μL , and most preferably less than about 0.1 μL .

One embodiment of the invention includes a method for determining the concentration of an analyte in a sample by, first, contacting the sample with an electrochemical sensor and then determining the concentration of the analyte. The electrochemical sensor includes a facing electrode pair with a working electrode and a counter electrode and a sample chamber, including a measurement zone, positioned between the two electrodes. The measurement zone is sized to contain less than about 1 μL of sample.

The invention also includes an electrochemical sensor with two or more facing electrode pairs. Each electrode pair has a working electrode, a counter electrode, and a measurement zone between the two electrodes, the measurement zone being sized to hold less than about 1 μL of sample. In addition, the sensor also includes non-leachable redox mediator on the working electrode of at least one of the electrode pairs.

One aspect of the invention is a method of determining the concentration of an analyte in a sample by contacting the sample with an electrochemical sensor and determining the concentration of the analyte by coulometry. The electrochemical sensor includes an electrode pair with a working electrode and a counter electrode. The sensor also includes a sample chamber for holding a sample in electrolytic contact with the working electrode. Within the sample chamber is sorbent material to reduce the volume sample needed to fill the sample chamber so that the sample chamber is sized to contain less than about 1 μL of sample.

The invention also includes a sensor and a method for the determination of the concentration of an analyte in a sample having a volume of less than about 1 μL . The sensor has a support and an air-oxidizable redox mediator coated on the support. At least 90% of the air-oxidizable redox mediator is in an oxidized state prior to introduction of a sample. The method includes contacting the sample with the sensor and correlating the concentration of the analyte in the sample to a change in oxidation state of the redox mediator in the presence of the sample. The sensor and method of this aspect of the invention are directed to, but not limited to, electrochemical and optical sensors.

A further aspect of the invention is an integrated sample acquisition and analyte measurement device which includes a sample acquisition means for producing a patient sample as well as a sensor of the invention for measuring analyte in the sample. The device is used for measuring analyte in a patient sample by, first, contacting the patient with the device and then determining the concentration of the analyte, preferably by coulometry.

Another aspect of the invention is a method for determining the concentration of an analyte in the sample with reduced error by contacting the sample with an electrochemical sensor that includes a first and a second electrode pair. Each electrode pair has a working electrode and a sample chamber for holding the sample in electrolytic contact with the working electrode, the sample chamber being sized to contain less than about 1 μL of sample. The first electrode pair also has a non-leachable redox mediator and non-leachable enzyme on the working electrode. The second electrode pair has a non-leachable redox mediator in the

absence of enzyme on the working electrode. The method further includes the step of measuring substantially simultaneously, and at two or more times, a first current generated at the first electrode pair and a second current generated at the second electrode pair. The measured first currents and second currents are independently
5 integrated to give a first charge and a second charge, respectively. The second charge is subtracted from the first charge to give a noise-reduced charge which is then correlated to the concentration of analyte in the sample. This method can be used to remove errors arising from interferences or the mixed oxidation state of the redox mediator prior to introduction of the sample.

10 Another method of the invention for the determination of the concentration of an analyte in a sample includes the step of providing an electrochemical sensor which has one or more facing electrode pairs, each pair having a working and a counter electrode and a measurement zone between the working and counter electrodes, the measurement zones of the one or more electrode
15 pairs having approximately equal volumes of less than about 1 μL . The sensor also includes redox mediator on the working electrode of at least one of the electrode pairs. The method further includes measuring a capacitance of one of the electrode pairs and calculating the volume of the measurement zone of that electrode pair from the capacitance measurement. In addition, the sensor is brought into contact with
20 the sample and the concentration of analyte in the sample is determined by coulometry.

A further aspect of the invention is a method of storing and packaging an analytical sensor which includes packaging the sensor in an atmosphere containing molecular oxygen. The sensor of this aspect of the invention includes
25 air-oxidizable redox mediator.

One embodiment of the invention is a method of determining the concentration of an analyte in a sample by contacting the sample with an electrochemical sensor, electrolyzing less than about 1 μL of sample, and determining the concentration of the analyte by coulometry. The sensor of this
30 embodiment of the invention includes a working electrode and non-leachable redox mediator on the working electrode. The molar amount of non-leachable redox mediator in the reduced form prior to introduction of the sample into the sensor is

less than, on a stoichiometric basis, 5% of the expected molar amount of analyte to be electrolyzed.

Another method for determining the concentration of an analyte in a sample includes contacting the sample with an electrochemical sensor which has a
5 working electrode, a counter electrode, and a measurement zone bounded on at least two sides by the two electrodes. The measurement zone is sized to contain less than about 1 μL of sample. The concentration of analyte in the sample is then determined by coulometry.

These and various other features which characterize the invention are
10 pointed out with particularity in the attached claims. For a better understanding of the invention, its advantages, and objectives obtained by its use, reference should be made to the drawings and to the accompanying description, in which there is illustrated and described preferred embodiments of the invention.

Brief Description of the Drawings

15 Referring now to the drawings, wherein like reference numerals and letters indicate corresponding structure throughout the several views:

Figure 1 is a schematic view of a first embodiment of an electrochemical sensor in accordance with the principles of the present invention having a working electrode and a counter electrode facing each other;

20 Figure 2 is a schematic view of a second embodiment of an electrochemical sensor in accordance with the principles of the present invention having a working electrode and a counter electrode in a coplanar configuration;

Figure 3 is a schematic view of a third embodiment of an electrochemical sensor in accordance with the principles of the present invention
25 having a working electrode and a counter electrode facing each other and having an extended sample chamber;

Figure 4 is a not-to-scale side-sectional drawing of a portion of the sensor of Figures 1 or 3 showing the relative positions of the redox mediator, the sample chamber, and the electrodes;

30 Figure 5 is a top view of an embodiment of a multiple electrode sensor in accordance with the principles of the present invention;

Figure 6 is a perspective view of an embodiment of an analyte measurement device in accordance with the principles of the present invention having a sample acquisition means and the sensor of Figure 4;

Figure 7 is a graph of the charge required to electrooxidize a known
5 quantity of glucose in an electrolyte buffered solution (filled circles) or serum solution (open circles) using the sensor of Figure 1 with glucose oxidase as the second electron transfer agent;

Figure 8 is a graph of the average glucose concentrations for the data
of Figure 7 (buffered solutions only) with calibration curves calculated to fit the
10 averages; a linear calibration curve was calculated for the 10-20 mM concentrations and a second order polynomial calibration curve was calculated for the 0-10 mM concentrations;

Figure 9 is a Clarke-type clinical grid analyzing the clinical relevance
of the glucose measurements of Figure 7;

Figure 10 is a graph of the charge required to electrooxidize a known
15 quantity of glucose in an electrolyte buffered solution using the sensor of Figure 1 with glucose dehydrogenase as the second electron transfer agent;

Figures 11A, 11B, and 11C are top views of three embodiments of an
electrochemical sensor of the present invention;

Figures 12A and 12B are cross-sectional views of another
20 embodiment of an electrochemical sensor of the present invention formed using a recess of a base material;

Figures 13A and 13B are cross-sectional views of yet another
embodiment of an electrochemical sensor or the present invention formed in a recess
25 of a base material; and

Figures 14A and 14B are cross-sectional view of a further
embodiment of an electrochemical sensor of the present invention formed using a
recess of a base material and a sorbent material.

Detailed Description of the Preferred Embodiment

When used herein, the following definitions define the stated term:

An "air-oxidizable mediator" is a redox mediator that is oxidized by air, preferably so that at least 90% of the mediator is in an oxidized state upon storage in air within a useful period of time, e.g., one month or less, and, preferably, one week or less, and, more preferably, one day or less.

A "biological fluid" is any body fluid in which the analyte can be measured, for example, blood, interstitial fluid, dermal fluid, sweat, and tears.

The term "blood" in the context of the invention includes whole blood and its cell-free components, namely, plasma and serum.

"Coulometry" is the determination of charge passed or projected to pass during complete or nearly complete electrolysis of the analyte, either directly on the electrode or through one or more electron transfer agents. The charge is determined by measurement of charge passed during partial or nearly complete electrolysis of the analyte or, more often, by multiple measurements during the electrolysis of a decaying current and elapsed time. The decaying current results from the decline in the concentration of the electrolyzed species caused by the electrolysis.

A "counter electrode" refers to an electrode paired with the working electrode, through which passes an electrochemical current equal in magnitude and opposite in sign to the current passed through the working electrode. In the context of the invention, the term "counter electrode" is meant to include counter electrodes which also function as reference electrodes (i.e. a counter/reference electrode).

An "electrochemical sensor" is a device configured to detect the presence and/or measure the concentration of an analyte via electrochemical oxidation and reduction reactions on the sensor. These reactions are transduced to an electrical signal that can be correlated to an amount or concentration of analyte.

"Electrolysis" is the electrooxidation or electroreduction of a compound either directly at an electrode or via one or more electron transfer agents.

The term "facing electrodes" refers to a configuration of the working and counter electrodes in which the working surface of the working electrode is disposed in approximate opposition to a surface of the counter electrode and where

the distance between the working and counter electrodes is less than the width of the working surface of the working electrode.

A compound is "immobilized" on a surface when it is entrapped on or chemically bound to the surface.

5 The "measurement zone" is defined herein as a region of the sample chamber sized to contain only that portion of the sample that is to be interrogated during the analyte assay.

10 A "non-leachable" or "non-releasable" compound is a compound which does not substantially diffuse away from the working surface of the working electrode for the duration of the analyte assay.

A "redox mediator" is an electron transfer agent for carrying electrons between the analyte and the working electrode, either directly, or via a second electron transfer agent.

15 A "second electron transfer agent" is a molecule which carries electrons between the redox mediator and the analyte.

"Sorbent material" is material which wicks, retains, or is wetted by a fluid sample in its void volume and which does not substantially prevent diffusion of the analyte to the electrode.

20 A "working electrode" is an electrode at which analyte is electrooxidized or electroreduced with or without the agency of a redox mediator.

A "working surface" is that portion of the working electrode which is coated with redox mediator and configured for exposure to sample.

25 The small volume, *in vitro* analyte sensors of the present invention are designed to measure the concentration of an analyte in a portion of a sample having a volume less than about 1 μL , preferably less than about 0.5 μL , more preferably less than about 0.2 μL , and most preferably less than about 0.1 μL . The analyte of interest is typically provided in a solution or biological fluid, such as blood or serum. Referring to the Drawings in general and Figures 1- 4 in particular, a small volume, *in vitro* electrochemical sensor 20 of the invention generally
30 includes a working electrode 22, a counter (or counter/reference) electrode 24, and a sample chamber 26 (see Figure 4). The sample chamber 26 is configured so that when a sample is provided in the chamber the sample is in electrolytic contact with

both the working electrode 22 and the counter electrode 24. This allows electrical current to flow between the electrodes to effect the electrolysis (electrooxidation or electroreduction) of the analyte.

5 Working Electrode

The working electrode 22 may be formed from a molded carbon fiber composite or it may consist of an inert non-conducting base material, such as polyester, upon which a suitable conducting layer is deposited. The conducting layer should have relatively low electrical resistance and should be
10 electrochemically inert over the potential range of the sensor during operation. Suitable conductors include gold, carbon, platinum, ruthenium dioxide and palladium, as well as other non-corroding materials known to those skilled in the art. The electrode and/or conducting layers are deposited on the surface of the inert material by methods such as vapor deposition or printing.

15 A tab 23 may be provided on the end of the working electrode 22 for easy connection of the electrode to external electronics (not shown) such as a voltage source or current measuring equipment. Other known methods or structures may be used to connect the working electrode 22 to the external electronics.

20 Sensing Layer and Redox Mediator

A sensing layer 32 containing a non-leachable (i.e., non-releasable) redox mediator is disposed on a portion of the working electrode 22. Preferably, there is little or no leaching of the redox mediator away from the working electrode 22 into the sample during the measurement period, which is typically less than about
25 5 minutes. More preferably, the redox mediators of the present invention are bound or otherwise immobilized on the working electrode 22 to prevent undesirable leaching of the mediator into the sample. A diffusing or leachable (i.e., releasable) redox mediator is not desirable when the working and counter electrodes are close together (i.e., when the electrodes are separated by less than about 1 mm), because a
30 large background signal is typically produced as the unbound mediator shuttles electrons between the working and counter electrodes, rather than between the analyte and the working electrode. This and other problems have hindered the

development of low resistance cells and increased the minimum sample size required for determination of analyte concentration.

Application of sensing layer 32 on working electrode 22 creates a working surface on that electrode. In general, the working surface is that portion of the working electrode 22 coated with mediator and able to contact a fluid sample. If
5 a portion of the sensing layer 32 is covered by a dielectric or other material, then the working surface will only be that portion of the electrode covered by redox mediator and exposed for contact with the sample.

The redox mediator mediates a current between the working electrode
10 22 and the analyte and enables the electrochemical analysis of molecules which are not suited for direct electrochemical reaction on an electrode. The mediator functions as an electron transfer agent between the electrode and the analyte.

Almost any organic or organometallic redox species can be used as a redox mediator. In general, the preferred redox mediators are rapidly reducible and
15 oxidizable molecules having redox potentials a few hundred millivolts above or below that of the standard calomel electrode (SCE), and typically not more reducing than about -100 mV and not more oxidizing than about +400mV versus SCE. Examples of organic redox species are quinones and quinhydrones and species that in their oxidized state have quinoid structures, such as Nile blue and indophenol.
20 Unfortunately, some quinones and partially oxidized quinhydrones react with functional groups of proteins such as the thiol groups of cysteine, the amine groups of lysine and arginine, and the phenolic groups of tyrosine which may render those redox species unsuitable for some of the sensors of the present invention, e.g., sensors that will be used to measure analyte in biological fluids such as blood.

25 In general, mediators suitable for use in the invention have structures which prevent or substantially reduce the diffusional loss of redox species during the period of time that the sample is being analyzed. The preferred redox mediators include a redox species bound to a polymer which can in turn be immobilized on the working electrode. Useful redox mediators and methods for producing them are
30 described in U.S. Patent Nos. 5,264,104; 5,356,786; 5,262,035; and 5,320,725, herein incorporated by reference. Although, any organic or organometallic redox species can be bound to a polymer and used as a redox mediator, the preferred redox

species is a transition metal compound or complex. The preferred transition metal compounds or complexes include osmium, ruthenium, iron, and cobalt compounds or complexes. The most preferred are osmium compounds and complexes.

One type of non-releasable polymeric redox mediator contains a redox species covalently bound in a polymeric composition. An example of this type of mediator is poly(vinylferrocene).

Alternatively, a suitable non-releasable redox mediator contains an ionically-bound redox species. Typically, these mediators include a charged polymer coupled to an oppositely charged redox species. Examples of this type of mediator include a negatively charged polymer such as Nafion[®] (DuPont) coupled to a positively charged redox species such as an osmium or ruthenium polypyridyl cation. Another example of an ionically-bound mediator is a positively charged polymer such as quaternized poly(4-vinyl pyridine) or poly(1-vinyl imidazole) coupled to a negatively charged redox species such as ferricyanide or ferrocyanide.

In another embodiment of the invention, the suitable non-releasable redox mediators include a redox species coordinatively bound to the polymer. For example, the mediator may be formed by coordination of an osmium or cobalt 2, 2'-bipyridyl complex to poly(1-vinyl imidazole) or poly(4-vinyl pyridine).

The preferred redox mediators are osmium transition metal complexes with one or more ligands having a nitrogen-containing heterocycle such as 2,2'-bipyridine, 1,10-phenanthroline or derivatives thereof. Furthermore, the preferred redox mediators also have one or more polymeric ligands having at least one nitrogen-containing heterocycle, such as pyridine, imidazole, or derivatives thereof. These preferred mediators exchange electrons rapidly between each other and the electrodes so that the complex can be rapidly oxidized and reduced.

In particular, it has been determined that osmium cations complexed with two ligands containing 2,2'-bipyridine, 1,10-phenanthroline, or derivatives thereof, the two ligands not necessarily being the same, and further complexed with a polymer having pyridine or imidazole functional groups form particularly useful redox mediators in the small volume sensors of the present invention. Preferred derivatives of 2,2'-bipyridine for complexation with the osmium cation are 4,4'-dimethyl-2,2'-bipyridine and mono-, di-, and polyalkoxy-2,2'-bipyridines, such as

4,4'-dimethoxy-2,2'-bipyridine, where the carbon to oxygen ratio of the alkoxy groups is sufficient to retain solubility of the transition metal complex in water. Preferred derivatives of 1,10-phenanthroline for complexation with the osmium cation are 4,7-dimethyl-1,10-phenanthroline and mono-, di-, and polyalkoxy-1,10-phenanthrolines, such as 4,7-dimethoxy-1,10-phenanthroline, where the carbon to oxygen ratio of the alkoxy groups is sufficient to retain solubility of the transition metal complex in water. Preferred polymers for complexation with the osmium cation include poly(1-vinyl imidazole), e.g., PVI, and poly(4-vinyl pyridine), e.g., PVP, either alone or with a copolymer. Most preferred are redox mediators with osmium complexed with poly(1-vinyl imidazole) alone or with a copolymer.

The preferred redox mediators have a redox potential between about -150 mV to about +400 mV versus the standard calomel electrode (SCE). Preferably, the potential of the redox mediator is between about -100 mV and +100 mV and more preferably, the potential is between about -50 mV and +50 mV. The most preferred redox mediators have osmium redox centers and a redox potential more negative than +100 mV versus SCE, more preferably the redox potential is more negative than +50 mV versus SCE, and most preferably is near -50 mV versus SCE.

It is also preferred that the redox mediators of the inventive sensors be air-oxidizable. This means that the redox mediator is oxidized by air, preferably so that at least 90% of the mediator is in an oxidized state prior to introduction of sample into the sensor. Air-oxidizable redox mediators include osmium cations complexed with two mono-, di-, or polyalkoxy-2,2'-bipyridine or mono-, di-, or polyalkoxy-1,10-phenanthroline ligands, the two ligands not necessarily being the same, and further complexed with polymers having pyridine and imidazole functional groups. In particular, $\text{Os}[4,4'\text{-dimethoxy-2,2'-bipyridine}]_2\text{Cl}^{+/+2}$ complexed with poly(4-vinyl pyridine) or poly(1-vinyl imidazole) attains approximately 90% or more oxidation in air.

In a preferred embodiment of the invention, the sensing layer includes a second electron transfer agent which is capable of transferring electrons to or from the redox mediator and the analyte. One example of a suitable second electron transfer agent is an enzyme which catalyzes a reaction of the analyte. For example, a glucose oxidase or glucose dehydrogenase, such as pyrroloquinoline

quinone glucose dehydrogenase (PQQ), is used when the analyte is glucose. A lactate oxidase fills this role when the analyte is lactate. These enzymes catalyze the electrolysis of an analyte by transferring electrons between the analyte and the electrode via the redox mediator. Preferably, the second electron transfer agent is
5 non-leachable, and more preferably immobilized on the electrode, to prevent unwanted leaching of the agent into the sample. This is accomplished, for example, by cross linking the second electron transfer agent with the redox mediator, thereby providing a sensing layer with non-leachable components.

To prevent electrochemical reactions from occurring on portions of
10 the working electrode not coated by the mediator, a dielectric 40 may be deposited on the electrode over, under, or surrounding the region with the bound redox mediator, as shown in Figure 4. Suitable dielectric materials include waxes and non-conducting organic polymers such as polyethylene. Dielectric 40 may also cover a portion of the redox mediator on the electrode. The covered portion of the mediator
15 will not contact the sample, and, therefore, will not be a part of the electrode's working surface.

Counter Electrode

Counter electrode 24 may be constructed in a manner similar to
20 working electrode 22. Counter electrode 24 may also be a counter/reference electrode. Alternatively, a separate reference electrode may be provided in contact with the sample chamber. Suitable materials for the counter/reference or reference electrode include Ag/AgCl printed on a non-conducting base material or silver chloride on a silver metal base. If the counter electrode is not a reference electrode,
25 the same materials and methods may be used to make the counter electrode as are available for constructing the working electrode 22, however, no redox mediator is immobilized on the counter or counter/reference electrode 24. A tab 25 may be provided on the electrode for convenient connection to the external electronics (not shown), such as a coulometer or other measuring device.

30 In one embodiment of the invention, working electrode 22 and counter electrode 24 are disposed opposite to and facing each other to form a facing electrode pair as depicted in Figures 1 and 3. In this preferred configuration, the

sample chamber 26 is typically disposed between the two electrodes. For this facing electrode configuration, it is preferred that the electrodes are separated by a distance of less than about 0.2mm, preferably less than 0.1 mm, and most preferably less than 0.05 mm.

5 The electrodes need not be directly opposing each other, they may be slightly offset. Furthermore, the two electrodes need not be the same size. Preferably, the counter electrode 24 is at least as large as the working surface of the working electrode 22. The counter electrode 22 can also be formed with tines in a comb shape. Other configuration of both the counter electrode and working
10 electrode are within the scope of the invention. However, the separation distance between any portion of the working electrode and some portion of the counter electrode preferably does not exceed the limits specified hereinabove.

 Figures 11A, 11B, and 11C illustrate different embodiments of pairs of facing electrodes 22, 24, as described above. A region 21 of overlap between the
15 two electrodes 22, 24 typically corresponds to the measurement zone in which the sample will be interrogated. Each of the electrodes 22, 24 is a conducting surface and acts as a plate of a capacitor. The measurement zone between the electrodes 22, 24 acts as a dielectric layer between the plates. Thus, there is a capacitance between the two electrodes 22, 24. This capacitance is a function of the size of the
20 overlapping electrodes 22, 24, the separation between the electrodes 22, 24, and the dielectric constant of the material between the electrodes 22,24. Thus, if the size of the region 21 of the overlapping electrodes 22, 24 and the dielectric constant of the material between the electrodes (e.g., air or a sorbent material) are known, then the separation between the electrodes can be calculated to determine the volume of the
25 measurement zone.

 Figure 11A illustrates one embodiment of the invention in which the electrodes 22, 24 are positioned in a facing arrangement. For the capacitance to be uniform among similarly constructed analyte sensors having this particular sensor configuration, the registration (i.e., the positioning of the two electrodes relative to
30 one another) should be uniform. If the position of either of the electrodes is shifted in the x-y plane from the position shown in Figure 11A, the size of the overlap, and

therefore, of the capacitance, will change. The same principle holds for the volume of the measurement zone.

Figures 11B and 11C illustrate other embodiments of the invention with electrodes 22, 24 in a facing arrangement. In these particular arrangements, the position of either of the electrodes may be shifted, by at least some minimum distance, in the x-y plane relative to the other electrode without a change in the capacitance or the volume of the measurement zone. In these electrode arrangements, each electrode 22, 24 includes an arm 122, 124, respectively, which overlaps with the corresponding arm of the other electrode. The two arms 122, 124 are not parallel to each other (such as illustrated in Figure 11A); rather, the arms 122, 124 are disposed at an angle 123, which is greater than zero, relative to each other. In addition, the two arms 122, 124 extend beyond the region 21 of overlap (i.e., each arm has extra length corresponding to the difference between the length of the arm 222, 224, respectively, and the width 121 of the overlap 21). With these electrode arrangements, there can be a certain amount of allowed imprecision in the registration of the electrodes 22, 24 which does not change the capacitance of the electrode arrangement. A desired amount of allowed imprecision in the registration can be designed into the electrode arrangement by varying the angle 123 at which the arms 122, 124 overlap and the size of the extra length of each arm 122, 124 relative to the width 121 of the region 21 of overlap. Typically, the closer that the arms 122, 124 are to being perpendicular (i.e., angle 123 is 90°), the greater the allowed imprecision. Also, the greater the extra length of each arm 122, 124 (which may both be the same length or different lengths) relative to the width 121 of the region 21 of overlap, the greater the allowed imprecision. Conversely, the greater the amount of allowed imprecision, the larger the size of the electrodes (for a given electrode width, thickness, and angle 123 of intersection with the other electrode). Thus, the minimum distance that one electrode can be shifted relative to the other is balanced against the amount of material needed for the electrodes. Typically, the angle 123 of intersection ranges from 5 to 90 degrees, preferably, 30 to 90 degrees, and more preferably 60 to 90 degrees. Typically, the ratio of the extra length of an arm 122, 124 (corresponding to the difference between the arm length 222, 224 and the width 121 of the region 21 of overlap) versus the width 121 of the region 21 of

overlap ranges from 0.1:1 to 50:1, preferably 1:1 to 15:1, and more preferably 4:1 to 10:1.

In another embodiment of the invention, the two electrodes 22, 24 are coplanar as shown in Figure 2. In this case, the sample chamber 26 is in contact
5 with both electrodes and is bounded on the side opposite the electrodes by a non-conducting inert base 30. Suitable materials for the inert base include non-conducting materials such as polyester.

Other configurations of the inventive sensors are also possible. For example, the two electrodes may be formed on surfaces that make an angle to each
10 other. One such configuration would have the electrodes on surfaces that form a right angle. Another possible configuration has the electrodes on a curved surface such as the interior of a tube. The working and counter electrodes may be arranged so that they face each other from opposite sides of the tube. This is another example of a facing electrode pair. Alternatively, the electrodes may be placed near each
15 other on the tube wall (e.g., one on top of the other or side-by-side).

In any configuration, the two electrodes must be configured so that they do not make direct electrical contact with each other, to prevent shorting of the electrochemical sensor. This may be difficult to avoid when the facing electrodes having a short (less than about 100 μ m) distance between them.

20 A spacer 28 can be used to keep the electrodes apart when the electrodes face each other as depicted in Figures 1 and 3. The spacer is typically constructed from an inert non-conducting material such as polyester, Mylar™, Kevlar™ or any other strong, thin polymer film, or, alternatively, a thin polymer film such as a Teflon™ film, chosen for its chemical inertness. In addition to
25 preventing contact between the electrodes, the spacer 28 often functions as a portion of the boundary for the sample chamber 26 as shown in Figures 1- 4.

Sample Chamber

The sample chamber 26 is typically defined by a combination of the
30 electrodes 22, 24, an inert base 30, and a spacer 28 as shown in Figures 1-4. A measurement zone is contained within this sample chamber and is the region of the sample chamber that contains only that portion of the sample that is interrogated

during the analyte assay. In the embodiment of the invention illustrated in Figures 1 and 2, sample chamber 26 is the space between the two electrodes 22, 24 and/or the inert base 30. In this embodiment, the sample chamber has a volume that is preferably less than about 1 μL , more preferably less than about 0.5 μL , and most preferably less than about 0.2 μL . In the embodiment of the invention depicted in Figures 1 and 2, the measurement zone has a volume that is approximately equal to the volume of the sample chamber.

In another embodiment of the invention, shown in Figure 3, sample chamber 26 includes much more space than the region proximate electrodes 22, 24. This configuration makes it possible to provide multiple electrodes in contact with one or more sample chambers, as shown in Figure 5. In this embodiment, sample chamber 26 is preferably sized to contain a volume of less than about 1 μL , more preferably less than about 0.5 μL , and most preferably less than about 0.2 μL . The measurement zone (i.e., the region containing the volume of sample to be interrogated) is generally sized to contain a volume of sample of less than about 1 μL , preferably less than about 0.5 μL , more preferably less than about 0.2 μL , and most preferably less than about 0.1 μL . One particularly useful configuration of this embodiment positions working electrode 22 and counter electrode 24 facing each other, as shown in Figure 3. In this embodiment, the measurement zone, corresponding to the region containing the portion of the sample which will be interrogated, is the portion of sample chamber 26 bounded by the working surface of the working electrode and disposed between the two facing electrodes. When the surface of the working electrode is not entirely covered by redox mediator, the measurement zone is the space between the two facing electrodes that has a surface area corresponding to the working surface (i.e., redox mediator-covered surface) of working electrode 22 and a thickness corresponding to the separation distance between working electrode 22 and counter electrode 24.

In both of the embodiments discussed above, the thickness of the sample chamber and of the measurement zone correspond typically to the thickness of spacer 28 (e.g., the distance between the electrodes in Figures 1 and 3, or the distance between the electrodes and the inert base in Figure 2). Preferably, this thickness is small to promote rapid electrolysis of the analyte, as more of the sample

will be in contact with the electrode surface for a given sample volume. In addition, a thin sample chamber helps to reduce errors from diffusion of analyte into the measurement zone from other portions of the sample chamber during the analyte assay, because diffusion time is long relative to the measurement time. Typically, the thickness of the sample chamber is less than about 0.2 mm. Preferably, the thickness of the sample chamber is less than about 0.1 mm and, more preferably, the thickness of the sample chamber is about 0.05 mm or less.

The sample chamber may be formed by other methods. Exemplary methods include embossing, indenting, or otherwise forming a recess in a substrate within which either the working electrode 22 or counter electrode 24 is formed. Figures 12A and 12B illustrate one embodiment of this structure. First, a conducting layer 100 is formed on an inert non-conducting base material 102. As described above, the conducting layer 100 can include gold, carbon, platinum, ruthenium dioxide, palladium, or other non-corroding materials. The inert non-conducting base material 102 can be made using a polyester, other polymers, or other non-conducting, deformable materials. A recess 104 is then formed in a region of the non-conducting base material 102 so that at least a portion of the conducting layer 100 is included in the recess 104. The recess 104 may be formed using a variety of techniques including indenting, deforming, or otherwise pushing in the base material 102. One additional exemplary method for forming the recess includes embossing the base material 102. For example, the base material 102 may be brought into contact with an embossing roll or stamp having raised portions, such as punch members or channels, to form the recess 104. In some embodiments, the base material 102 may be heated to soften the material.

The recess 104 may be circular, oval, rectangular, or any other regular or irregular shape. Alternatively, the recess 104 may be formed as a channel which extends along a portion of the base material 102. The conducting layer 100 may extend along the entire channel or only a portion of the channel. The measurement zone may be restricted to a particular region within the channel by, for example, depositing the sensing layer 32 on only that portion of the conducting layer 100 within the particular region of the channel. Alternatively, the measurement zone

may be defined by placing a second electrode 107 over only the desired region of the first electrode 105.

At least a portion, and in some cases, all, of the conducting layer 100 is situated in the recess 104. This portion of the conducting layer 100 may act as a first electrode 105 (a counter electrode or, preferably, a working electrode). If the conducting layer 100 forms the working electrode, then a sensing layer 32 may be formed over a portion of the conducting layer 100 by depositing the non-leachable mediator and optional second electron transfer agent in the recess 104, as shown in Figure 12B. A second electrode 107 is then formed by depositing a second conducting layer on a second base material 106. This second electrode 107 is then positioned over the first electrode 105 in a facing arrangement. Although not illustrated, it will be understood that if the first electrode 105 were to function as a counter electrode, then the sensing layer 32 would be deposited on the second electrode 107 which would then function as the working electrode.

In one embodiment, the second base material 108 rests on a portion of the first base material 102 and/or the conducting layer 100 which is not depressed, so that the second electrode 107 extends into the recess. In another embodiment, there is a spacer (not shown) between the first and second base materials 102, 108. In this embodiment, the second electrode 107 may or may not extend into the recess. In any case, the first and second electrodes 105, 107 do not make contact, otherwise the two electrodes would be shorted.

The depth of the recess 104 and the volume of the conductive layer 100, sensing layer 32, and the portion, if any, of the second electrode 107 in the recess 104 determines the volume of the measurement zone. Thus, the predictability of the volume of the measurement zone relies on the extent to which the formation of the recess 104 is uniform.

In addition to the conducting layer 100, a sorbent layer 103, described in detail below, may be deposited on the base material 102 prior to forming the recess 104, as shown in Figure 14A. The sorbent material 103 may be indented, embossed, or otherwise deformed with the conducting layer 100 and base material 102, as shown in Figure 14B. Alternatively, the sorbent material 103 may be

deposited after the conducting layer 100 and base material 102 are indented, embossed, or otherwise deformed to make the recess 104.

In another exemplary method for forming the analyte sensor. A recess 114 is formed in a first base material 112, as shown in Figures 13A and 13B.

5 The recess may be formed by indenting, embossing, etching (e.g., using photolithographic methods or laser removal of a portion of the base material), or otherwise deforming or removing a portion of the base material 112. Then a first conducting layer 110 is formed in the recess 114. Any of the conductive materials discussed above may be used. A preferred material is a conductive ink, such as a
10 conductive carbon ink available, for example, from Ercon, Inc. (Wareham, MA). The conductive ink typically contains metal or carbon dissolved or dispersed in a solvent or dispersant. When the solvent or dispersant is removed, the metal or carbon forms a conductive layer 110 that can then be used as a first electrode 115. A second electrode 117 can be formed on a second base material 116 and positioned
15 over the recess 114, as described above. In some embodiments, a sensing layer 32 is formed on the first electrode 115 to form a working electrode, as shown in Figure 13B. In other embodiments, the sensing layer 32 may be formed on the second electrode 117 to form a working electrode. Furthermore, a sorbent material (not shown) may be formed within the recess, for example, on the first electrode 115.

20 A binder, such as a polyurethane resin, cellulose derivative, elastomer (e.g., silicones, polymeric dienes, or acrylonitrile-butadiene-styrene (ABS) resins), highly fluorinated polymers, or the like, may also be included in the conductive ink. Curing the binder may increase the conductivity of the conductive layer 110, however, curing is not necessary. The method of curing the binder may depend on
25 the nature of the particular binder that is used. Some binders are cured by heat and/or ultraviolet light.

These structures allow for the formation of electrochemical sensors in which the volume of the measurement zone depends, at least in part, on the accuracy and reproducibility of the recess 104. Embossing, laser etching, photolithographic
30 etching and other methods can be used to make reproducible recesses 104, even on the scale of 200 μm or less.

Sorbent Material

The sample chamber may be empty before the sample is placed in the chamber. Alternatively, the sample chamber may include a sorbent material 34 to sorb and hold a fluid sample during the measurement process. Suitable sorbent materials include polyester, nylon, cellulose, and cellulose derivatives such as nitrocellulose. The sorbent material facilitates the uptake of small volume samples by a wicking action which may complement or, preferably, replace any capillary action of the sample chamber.

In some embodiments, the sorbent material is deposited using a liquid or slurry in which the sorbent material is dissolved or dispersed. The solvent or dispersant in the liquid or slurry may then be driven off by heating or evaporation processes. Suitable sorbent materials include, for example, cellulose or nylon powders dissolved or dispersed in a suitable solvent or dispersant, such as water. The particular solvent or dispersant should also be compatible with the material of the working electrode 22 (e.g., the solvent or dispersant should not dissolve the electrode.)

One of the most important functions of the sorbent material is to reduce the volume of fluid needed to fill the sample chamber and corresponding measurement zone of the sensor. The actual volume of sample within the measurement zone is partially determined by the amount of void space within the sorbent material. Typically, suitable sorbents consist of about 5% to about 50% void space. Preferably, the sorbent material consists of about 10% to about 25% void space.

The displacement of fluid by the sorbent material is advantageous. By addition of a sorbent, less sample is needed to fill sample chamber 26. This reduces the volume of sample that is required to obtain a measurement and also reduces the time required to electrolyze the sample.

The sorbent material 34 may include a tab 33 which is made of the same material as the sorbent and which extends from the sensor, or from an opening in the sensor, so that a sample may be brought into contact with tab 33, sorbed by the tab, and conveyed into the sample chamber 26 by the wicking action of the sorbent material 34. This provides a preferred method for directing the sample into

the sample chamber 26. For example, the sensor may be brought into contact with a region of an animal (including human) that has been pierced with a lancet to draw blood. The blood is brought in contact with tab 33 and drawn into sample chamber 26 by the wicking action of the sorbent 34. The direct transfer of the sample to the sensor is especially important when the sample is very small, such as when the lancet is used to pierce a portion of the animal that is not heavily supplied with near-surface capillary vessels and furnishes a blood sample volume of less than 1 μ L.

Methods other than the wicking action of a sorbent may be used to transport the sample into the sample chamber or measurement zone. Examples of such means for transport include the application of pressure on a sample to push it into the sample chamber, the creation of a vacuum by a pump or other vacuum-producing means in the sample chamber to pull the sample into the chamber, capillary action due to interfacial tension of the sample with the walls of a thin sample chamber, as well as the wicking action of a sorbent material.

The sensor can also be used in conjunction with a flowing sample stream. In this configuration, the sample stream is made to flow through a sample chamber. The flow is stopped periodically and the concentration of the analyte is determined by electrochemical method, such as coulometry. After the measurement, the flow is resumed, thereby removing the sample from the sensor. Alternatively, sample may flow through the chamber at a very slow rate, such that all of the analyte is electrolyzed in transit, yielding a current dependent only upon analyte concentration and flow rate.

Other filler materials may be used to fill the measurement zone and reduce the sample volume. For example, glass beads can be deposited in the measurement zone to occupy space. Preferably, these filler materials are hydrophilic so that the body fluid can easily flow into the measurement zone. In some cases, such as glass beads with a high surface area, these filler materials may also wick the body fluid into the measurement zone due to their high surface area and hydrophilicity.

The entire sensor assembly is held firmly together to ensure that the sample remains in contact with the electrodes and that the sample chamber and measurement zone maintain the same volume. This is an important consideration in

the coulometric analysis of a sample, where measurement of a defined sample volume is needed. One method of holding the sensor together is depicted in Figures 1 and 2. Two plates 38 are provided at opposite ends of the sensor. These plates are typically constructed of non-conducting materials such as plastics. The plates are designed so that they can be held together with the sensor between the two plates. Suitable holding devices include adhesives, clamps, nuts and bolts, screws, and the like.

Integrated Sample Acquisition and Analyte Measurement Device

In a preferred embodiment of the invention, an analyte measurement device 52 constructed according to the principles of the present invention includes a sensor 20, as described hereinabove, combined with a sample acquisition means 50 to provide an integrated sampling and measurement device. The sample acquisition means 50 illustrated in Figure 6, includes, for example, a skin piercing member 54, such as a lancet, attached to a resilient deflectable strip 56 (or other similar device, such as a spring) which may be pushed to inject the lancet into a patient's skin to cause blood flow.

The resilient strip 56 is then released and the skin piercing member 54 retracts. Blood flowing from the area of skin pierced by member 54 can then be transported, for example, by the wicking action of sorbent material 34, into sensor 20 for analysis of the analyte. The analyte measurement device 52 may then be placed in a reader, not shown, which connects a coulometer or other electrochemical analysis equipment to the electrode tabs 23, 25 to determine the concentration of the analyte by electroanalytical means.

25

Operation of the Sensor

An electrochemical sensor of the invention is operated in the following manner. A potential is applied across the working and counter electrodes. The magnitude of the required potential is dependent on the redox mediator. The potential at an electrode where the analyte is electrolyzed is typically large enough to drive the electrochemical reaction to or near completion, but the magnitude of the potential is, preferably, not large enough to induce significant electrochemical

reaction of interferents, such as urate, ascorbate, and acetaminophen, that may affect the current measurements. Typically the potential is between about -150 mV and about +400 mV versus the standard calomel electrode (SCE). Preferably, the potential of the redox mediator is between about -100 mV and +100 mV and, more preferably, the potential is between about -50 mV and +50 mV.

The potential may be applied either before or after the sample has been placed in the sample chamber. The potential is preferably applied after the sample has come to rest in the sample chamber to prevent electrolysis of sample passing through the measurement zone as the sample chamber is filling. When the potential is applied and the sample is in the measurement zone, an electrical current will flow between the working electrode and the counter electrode. The current is a result of the electrolysis of the analyte in the sample. This electrochemical reaction occurs via the redox mediator and the optional second electron transfer agent. For many biomolecules, B, the process is described by the following reaction equations:

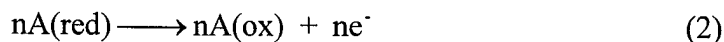
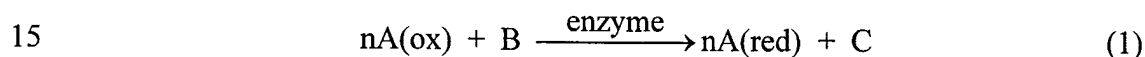

Biochemical B is oxidized to C by redox mediator species A in the presence of an appropriate enzyme. Then the redox mediator A is oxidized at the electrode.

Electrons are collected by the electrode and the resulting current is measured.

As an example, one sensor of the present invention is based on the reaction of a glucose molecule with two non-leachable ferricyanide anions in the presence of glucose oxidase to produce two non-leachable ferrocyanide anions, two protons and gluconolactone. The amount of glucose present is assayed by electrooxidizing the non-leachable ferrocyanide anions to non-leachable ferricyanide anions and measuring the total charge passed.

Those skilled in the art will recognize that there are many different reaction mechanisms that will achieve the same result; namely the electrolysis of an analyte through a reaction pathway incorporating a redox mediator. Equations (1) and (2) are a non-limiting example of such a reaction.

In a preferred embodiment of the invention, coulometry is used to determine the concentration of the analyte. This measurement technique utilizes current measurements obtained at intervals over the course of the assay, to determine analyte concentration. These current measurements are integrated over time to
5 obtain the amount of charge, Q, passed to or from the electrode. Q is then used to calculate the concentration of the analyte by the following equation:

$$[\text{analyte}] = Q/nFV \quad (3)$$

where n is the number of electron equivalents required to electrolyze the analyte, F is Faraday's constant (approximately 96,500 coulombs per equivalent), and V is the
10 volume of sample in the measurement zone.

In one embodiment of the invention, the analyte is completely or nearly completely electrolyzed. The charge is then calculated from current measurements made during the electrochemical reaction and the concentration of the analyte is determined using equation (3). The completion of the electrochemical
15 reaction is typically signaled when the current reaches a steady-state value. This indicates that all or nearly all of the analyte has been electrolyzed. For this type of measurement, at least 90% of the analyte is typically electrolyzed, preferably, at least 95% of the analyte is electrolyzed and, more preferably, at least 99% of the analyte is electrolyzed.

20 For this method it is desirable that the analyte be electrolyzed quickly. The speed of the electrochemical reaction depends on several factors, including the potential that is applied between the electrodes and the kinetics of reactions (1) and (2). (Other significant factors include the size of the measurement zone and the presence of sorbent in the measurement zone.) In general, the larger
25 the potential, the larger the current through the cell (up to a transport limited maximum) and therefore, the faster the reaction will typically occur. However, if the potential is too large, other electrochemical reactions may introduce significant error in the measurement. Typically, the potential between the electrodes as well as the specific redox mediator and optional second electron transfer agent are chosen so
30 that the analyte will be almost completely electrolyzed in less than 5 minutes, based on the expected concentration of the analyte in the sample. Preferably, the analyte

will be almost completely electrolyzed within about 2 minutes and, more preferably, within about 1 minute.

In another embodiment of the invention, the analyte is only partially electrolyzed. The current is measured during the partial reaction and then
5 extrapolated using mathematical techniques known to those skilled in the art to determine the current curve for the complete or nearly complete electrolysis of the analyte. Integration of this curve yields the amount of charge that would be passed if the analyte were completely or nearly completely electrolyzed and, using equation (3), the concentration of the analyte is calculated.

10 The above described methods are based on coulometric analyses, due to the advantages of coulometric measurements, as described hereinbelow.

However, those skilled in the art will recognize that a sensor of the invention may also utilize potentiometric, amperometric, voltammetric, and other electrochemical techniques to determine the concentration of an analyte in a sample. There are,

15 however, disadvantages to using some of these techniques. The measurements obtained by these non-coulometric methods are not temperature independent as the current and potential obtained by the electrolysis of an analyte on an electrode is very sensitive to sample temperature. This presents a problem for the calibration of a sensor which will be used to measure bioanalytes and other samples at unknown or
20 variable temperatures.

In addition, the measurements obtained by these non-coulometric electrochemical techniques are sensitive to the amount of enzyme provided in the sensor. If the enzyme deactivates or decays over time, the resulting measurements will be affected. This will limit the shelf life of such sensors unless the enzyme is
25 very stable.

Finally, the measurements obtained by non-coulometric electrochemical techniques such as amperometry will be negatively affected if a substantial portion of the analyte is electrolyzed during the measurement period. An accurate steady-state measurement can not be obtained unless there is sufficient
30 analyte so that only a relatively small portion of the analyte is electrolyzed during the measurement process.

The electrochemical technique of coulometry overcomes these problems. Coulometry is a method for determining the amount of charge passed or projected to pass during complete or nearly complete electrolysis of the analyte. One coulometric technique involves electrolyzing the analyte on a working electrode and measuring the resulting current between the working electrode and a counter electrode at two or more times during the electrolysis. The electrolysis is complete when the current reaches a steady state. The charge used to electrolyze the sample is then calculated by integrating the measured currents over time. Because the charge is directly related to the amount of analyte in the sample there is no temperature dependence of the measurement. In addition, the activity of the redox mediator does not affect the value of the measurement, but only the time required to obtain the measurement (i.e., less active redox mediator requires a longer time to achieve complete electrolysis of the sample) so that decay of the mediator over time will not render the analyte concentration determination inaccurate. And finally, the depletion of the analyte in the sample by electrolysis is not a source of error, but rather the objective of the technique. (However, the analyte need not be completely electrolyzed if the electrolysis curve is extrapolated from the partial electrolysis curve based on well-known electrochemical principles.)

For coulometry to be an effective measurement technique for determining the concentration of an analyte in a sample, it is necessary to accurately determine the volume of the measured sample. Unfortunately, the volume of the sample in the measurement zone of a small volume sensor (i.e., less than one microliter) may be difficult to accurately determine because the manufacturing tolerances of one or more dimensions of the measurement zone may have significant variances.

Air-oxidizable Redox Mediators

Another source of error in a coulometric sensor is the presence of electrochemical reactions other than those associated with the analyte. In a sensor having a redox mediator, a potential source of measurement error is the presence of redox mediator in an unknown mixed oxidation state (i.e., mediator not reproducibly in a known oxidation state). Redox mediator will then be electrolyzed at the

electrode, not in response to the presence of an analyte, but simply due to its initial oxidation state. Referring to equations (1) and (2), current not attributable to the oxidation of biochemical B will flow due to oxidation of a portion of a redox mediator, A, that is in its reduced form prior to the addition of the sample. Thus, it is important to know the oxidation state of the analyte prior to introduction of the sample into the sensor. Furthermore, it is desirable that all or nearly all of the redox mediator be in a single oxidation state prior to the introduction of the sample into the sensor.

Each redox mediator has a reduced form or state and an oxidized form or state. In one aspect of the invention, it is preferred that the amount of redox mediator in the reduced form prior to the introduction of sample be significantly smaller than the expected amount of analyte in a sample in order to avoid a significant background contribution to the measured current. In this embodiment of the invention, the molar amount of redox mediator in the reduced form prior to the introduction of the analyte is preferably less than, on a stoichiometric basis, about 10%, and more preferably less than about 5%, and most preferably less than 1%, of the molar amount of analyte for expected analyte concentrations. (The molar amounts of analyte and redox mediator should be compared based on the stoichiometry of the applicable redox reaction so that if two moles of redox mediator are needed to electrolyze one mole of analyte, then the molar amount of redox mediator in the reduced form prior to introduction of the analyte is preferably less than 20% and more preferably less than about 10% and most preferably less than about 2% of the molar amount of analyte for expected analyte concentrations.) Methods for controlling the amount of reduced mediator are discussed below.

In another aspect of the invention, it is preferred that the relative ratio of oxidized redox mediator to reduced redox mediator prior to introduction of the sample in the sensor be relatively constant between similarly constructed sensors. The degree of variation in this ratio between similarly constructed sensors will negatively affect the use of a calibration curve to account for the reduced mediator, as significant variations between sensors will make the calibration less reliable. For this aspect of the invention, the percentage of the redox mediator in the reduced form

prior to introduction of the sample in the sensor varies by less than about 20% and preferably less than about 10% between similarly constructed sensors.

One method of controlling the amount of reduced redox mediator prior to the introduction of the sample in the sensor is to provide an oxidizer to oxidize the reduced form of the mediator. One of the most convenient oxidizers is O_2 . Oxygen is usually readily available to perform this oxidizing function. Oxygen can be supplied by exposing the sensor to air. In addition, most polymers and fluids absorb O_2 from the air unless special precautions are taken. Typically, at least 90% of an air-oxidizable (i.e., O_2 oxidizable) mediator is in the oxidized state upon storage or exposure to air for a useful period of time, e.g., one month or less, and preferably, one week or less, and, more preferably, one day or less.

Suitable mediators which are both air-oxidizable (i.e., O_2 -oxidizable) and have electron transfer capabilities have been described hereinabove. One particular family of useful mediators are osmium complexes which are coordinated or bound to ligands with one or more nitrogen-containing heterocycles. In particular, osmium complexed with mono-, di-, and polyalkoxy-2,2'-bipyridine or mono-, di-, and polyalkoxy-1,10-phenanthroline, where the alkoxy groups have a carbon to oxygen ratio sufficient to retain solubility in water, are air-oxidizable. These osmium complexes typically have two substituted bipyridine or substituted phenanthroline ligands, the two ligands not necessarily being identical. These osmium complexes are further complexed with a polymeric ligand with one or more nitrogen-containing heterocycles, such as pyridine and imidazole. Preferred polymeric ligands include poly(4-vinyl pyridine) and, more preferably, poly(1-vinyl imidazole) or copolymers thereof. $Os[4,4'$ -dimethoxy-2,2'-bipyridine] $_2Cl^{+/+2}$ complexed with a poly(1-vinyl imidazole) or poly(4-vinyl pyridine) has been shown to be particularly useful as the Os^{+2} cation is oxidizable by O_2 to Os^{+3} . Similar results are expected for complexes of $Os[4,7$ -dimethoxy-1,10-phenanthroline] $_2Cl^{+/+2}$, and other mono-, di-, and polyalkoxy bipyridines and phenanthrolines, with the same polymers.

A complication associated with air-oxidizable mediators arises if the air oxidation of the redox mediator is so fast that a substantial portion of the analyte-reduced redox mediator is oxidized by O_2 during an analyte assay. This will result in

an inaccurate assay as the amount of analyte will be underestimated because the mediator will be oxidized by the oxidizer rather than by electrooxidation at the electrode. Thus, it is preferred that the reaction of the redox mediator with O₂ proceeds more slowly than the electrooxidation of the mediator. Typically, less than 5 5%, and preferably less than 1%, of the reduced mediator should be oxidized by the oxidizer during an assay.

The reaction rate of the air oxidation of the mediator can be controlled through choice of an appropriate complexing polymer. For example, the oxidation reaction is much faster for Os[4,4'-dimethoxy-2,2'-bipyridine]₂Cl⁺² 10 coordinatively coupled to poly(1-vinyl imidazole) than for the same Os complex coupled to poly(4-vinyl pyridine). The choice of an appropriate polymer will depend on the expected analyte concentration and the potential applied between the electrodes, both of which determine the rate of the electrochemical reaction.

Thus, in one embodiment of the invention, the preferred redox 15 mediator has the following characteristics: 1) the mediator does not react with any molecules in the sample or in the sensor other than the analyte (optionally, via a second electron transfer agent); 2) nearly all of the redox mediator is oxidized by an oxidizer such as O₂ prior to introduction of the sample in the sensor; and 3) the oxidation of the redox mediator by the oxidizer is slow compared to the 20 electrooxidation of the mediator by the electrode.

Alternatively, if the redox mediator is to be oxidized in the presence of the analyte and electroreduced at the electrode, a reducer rather than an oxidizer would be required. The same considerations for the appropriate choice of reducer and mediator apply as described hereinabove for the oxidizer.

25 The use of stable air-oxidizable redox mediators in the electrochemical sensors of the invention provides an additional advantage during storage and packaging. Sensors of the invention which include air oxidizable redox mediators can be packaged in an atmosphere containing molecular oxygen and stored for long periods of time, e.g., greater than one month, while maintaining more 30 than 80% and preferably more than 90% of the redox species in the oxidized state.

Optical Sensors

The air-oxidizable redox species of the present invention can be used in other types of sensors. The osmium complexes described hereinabove are suitable for use in optical sensors, due to the difference in the absorption spectra and
5 fluorescence characteristics of the complexed Os^{+2} and Os^{+3} species. Absorption, transmission, reflection, or fluorescence measurements of the redox species will correlate with the amount of analyte in the sample (after reaction between an analyte and the redox species, either directly, or via a second electron transfer agent such as an enzyme). In this configuration, the molar amount of redox mediator should be
10 greater, on a stoichiometric basis, than the molar amount of analyte reasonably expected to fill the measurement zone of the sensor.

Standard optical sensors, including light-guiding optical fiber sensors, and measurement techniques can be adapted for use with the air-oxidizable mediators. For example, the optical sensors of the invention may include a light-
15 transmitting or light reflecting support on which the air-oxidizable redox species, and preferably an analyte-responsive enzyme, is coated to form a film. The support film forms one boundary for the measurement zone in which the sample is placed. The other boundaries of the measurement zone are determined by the configuration of the cell. Upon filling the measurement zone with an analyte-containing sample,
20 reduction of the air-oxidizable mediator by the analyte, preferably via reaction with the analyte-responsive enzyme, causes a shift in the mediator's oxidation state that is detected by a change in the light transmission, absorption, or reflection spectra or in the fluorescence of the mediator at one or more wavelengths of light.

25 Multiple Electrode Sensors and Calibration

Multiple electrode sensors may be used for a variety of reasons. For example, multiple electrode sensors may be used to test a variety of analytes using a single sample. One embodiment of a multiple electrode sensor has one or more sample chambers which in turn may contain one or more working electrodes 22 with
30 each working electrode 22 defining a different measurement zone. One or more of the working electrodes have the appropriate chemical reagents, for example, an appropriate enzyme, to test a first analyte and one or more of the remaining working

electrodes have appropriate chemical reagents to test a second analyte. For example, a multiple electrode sensor might include 1) one or more working electrodes having glucose oxidase in the sensing layer to determine glucose concentration and 2) one or more working electrodes having lactate oxidase in the sensing layer to determine lactate concentration. Other combinations are also possible.

Multiple electrode sensors may also be used to improve the precision of the resulting readings. The measurements from each of the working electrodes (all or which are detecting the same analyte) can be averaged together to obtain a more precise reading. In some cases, measurements may be rejected if the difference between the value and the average exceeds a threshold limit. This threshold limit may be, for example, determined based on a statistical parameter, such as the standard deviation of the averaged measurements. The average may then be recalculated while omitting the rejected values. Furthermore, subsequent readings from an electrode that produced a rejected value may be ignored in later tests if it is assumed that the particular electrode is faulty. Alternatively, a particular electrode may be rejected only after having a predetermined number of readings rejected based on the readings from the other electrodes.

In addition to using multiple electrode sensors to increase precision, multiple measurements may be made at each electrode and averaged together to increase precision. This technique may also be used with a single electrode sensor to increase precision.

Errors in assays may occur when mass produced sensor are used because of variations in the volume of the measurement zone of the sensors. Two of the three dimensions of the measurement zone, the length and the width, are usually relatively large, between about 1-5 mm. Electrodes of such dimensions can be readily produced with a variance of 2% or less. The submicroliter measurement zone volume requires, however, that the third dimension be smaller than the length or width by one or two order of magnitude. As mentioned hereinabove, the thickness of the sample chamber is typically between about 0.1 and about 0.01 mm. Manufacturing variances in the thickness may be as large or larger than the desired thickness. Therefore, it is desirable that a method be provided to accommodate for this uncertainty in the volume of sample within the measurement zone.

In one embodiment of the invention, depicted in Figure 5, multiple working electrodes 42, 44, 46 are provided on a base material 48. These electrodes are covered by another base, not shown, which has counter electrodes, not shown, disposed upon it to provide multiple facing electrode pairs. The variance in the separation distance between the working electrode and the counter electrode among the electrode pairs on a given sensor is significantly reduced, because the working electrodes and counter electrodes are each provided on a single base with the same spacer 28 between each electrode pair (see Figure 3).

One example of a multiple electrode sensor that can be used to accurately determine the volume of the measurement zones of the electrode pairs and also useful in reducing noise is presented herein. In this example, one of the working electrodes 42 is prepared with a non-leachable redox mediator and a non-leachable second electron transfer agent (e.g., an enzyme). Sorbent material may be disposed between that working electrode 42 and its corresponding counter electrode. Another working electrode 44 includes non-leachable redox mediator, but no second electron transfer agent on the electrode. Again, this second electrode pair may have sorbent material between the working electrode 44 and the corresponding counter electrode. An optional third working electrode 46 has no redox mediator and no second electron transfer agent bound to the electrode, nor is there sorbent material between the working electrode 46 and its corresponding counter electrode.

The thickness of the sample chamber can be determined by measuring the capacitance, preferably in the absence of any fluid, between electrode 46 (or any of the other electrodes 42, 44 in the absence of sorbent material) and its corresponding counter electrode. The capacitance of an electrode pair depends on the surface area of the electrodes, the interelectrode spacing, and the dielectric constant of the material between the plates. The dielectric constant of air is unity which typically means that the capacitance of this electrode configuration is a few picofarads (or about 100 picofarads if there is fluid between the electrode and counter electrode given that the dielectric constant for most biological fluids is approximately 75). Thus, since the surface area of the electrodes are known, measurement of the capacitance of the electrode pair allows for the determination of the thickness of the measurement zone to within about 1-5%.

The amount of void volume in the sorbent material, can be determined by measuring the capacitance between electrode 44 (which has no second electron transfer agent) and its associated counter electrode, both before and after fluid is added. Upon adding fluid, the capacitance increases markedly since the fluid has a much larger dielectric constant. Measuring the capacitance both with and without fluid allows the determination of the spacing between the electrodes and the void volume in the sorbent, and thus the volume of the fluid in the reaction zone.

The sensor error caused by redox mediator in a non-uniform oxidation state prior to the introduction of the sample can be measured by concurrently electrolyzing the sample in the measurement zones that are proximate electrodes 42 and 44. At electrode 42, the analyte is electrolyzed to provide the sample signal. At electrode 44, the analyte is not electrolyzed because of the absence of the second electron transfer agent (assuming that a second electron transfer agent is necessary). However, a small charge will pass (and a small current will flow) due to the electrolysis of the redox mediator that was in a mixed oxidation state (i.e., some redox centers in the reduced state and some in the oxidized state) prior to the introduction of the sample. The small charge passed between the electrodes in this second electrode pair can be subtracted from the charge passed between the first electrode pair to substantially remove the error due to the oxidation state of the redox mediator. This procedure also reduces the error associated with other electrolyzed interferences, such as ascorbate, urate, and acetaminophen, as well as errors associated with capacitive charging and faradaic currents.

Other electrode configurations can also use these techniques (i.e., capacitance measurements and coulometric measurements in the absence of a critical component) to reduce background noise and error due to interferences and imprecise knowledge of the volume of the interrogated sample. Protocols involving one or more electrode pairs and one or more of the measurements described above can be developed and are within the scope of the invention. For example, only one electrode pair is needed for the capacitance measurements, however, additional electrode pairs may be used for convenience.

EXAMPLES

The invention will be further characterized by the following examples. These examples are not meant to limit the scope of the invention which has been fully set forth in the foregoing description. Variations within the concepts of the invention are apparent to those skilled in the art.

Example 1
Preparation of a Small Volume *in vitro* Sensor
for the Determination of Glucose Concentration

10

A sensor was constructed corresponding to the embodiment of the invention depicted in Figure 1. The working electrode was constructed on a Mylar™ film (DuPont), the Mylar™ film having a thickness of 0.175 mm and a diameter of about 2.5 cm. An approximately 12 micron thick carbon pad having a diameter of about 1 cm was screen printed on the Mylar™ film. The carbon electrode was overlaid with a water-insoluble dielectric insulator (Insulayer) having a thickness of 12 μm, and a 4 mm diameter opening in the center.

The center of the carbon electrode, which was not covered by the dielectric, was coated with a redox mediator. The redox mediator was formed by complexing poly(1-vinyl imidazole) with $\text{Os}(4,4'\text{-dimethoxy-2,2'}\text{-bipyridine})_2\text{Cl}_2$ followed by cross-linking glucose oxidase with the osmium polymer using polyethylene glycol diglycidyl ether as described in Taylor, et al., *J. Electroanal. Chem.*, 396:511 (1995). The ratio of osmium to imidazole functionalities in the redox mediator was approximately 1:15. The mediator was deposited on the working electrode in a layer having a thickness of 0.6 μm and a diameter of 4 mm. The coverage of the mediator on the electrode was about 60 μg/cm² (dry weight). A spacer material was placed on the electrode surrounding the mediator-covered surface of the electrode. The spacer was made of poly(tetrafluoroethylene) (PTFE) and had a thickness of about 0.040 mm.

30

A sorbent material was placed in contact with the mediator-covered surface of the working electrode. The sorbent was made of nylon (Tetko Nitex nylon 3-10/2) and had a diameter of 5 mm, a thickness of 0.045 mm, and a void volume of about 20%. The volume of sample in the measurement zone was

calculated from the dimensions and characteristics of the sorbent and the electrode. The measurement zone had a diameter of 4 mm (the diameter of the mediator covered surface of the electrode) and a thickness of 0.045 mm (thickness of the nylon sorbent) to give a volume of 0.57 μL . Of this space, about 80% was filled
5 with nylon and the other 20% was void space within the nylon sorbent. This resulting volume of sample within the measurement zone was about 0.11 μL .

A counter/reference electrode was placed in contact with the spacer and the side of the sorbent opposite to the working electrode so that the two electrodes were facing each other. The counter/reference electrode was constructed
10 on a Mylar™ film having a thickness of 0.175 mm and a diameter of about 2.5 cm onto which a 12 micron thick layer of silver/silver chloride having a diameter of about 1 cm was screen printed.

The electrodes, sorbent, and spacer were pressed together using plates on either side of the electrode assembly. The plates were formed of polycarbonate
15 plastic and were securely clamped to keep the sensor together. The electrodes were stored in air for 48 hours prior to use.

Tabs extended from both the working electrode and the counter/reference electrode and provided for an electrical contact with the analyzing equipment. A potentiostat was used to apply a potential difference of +200mV
20 between the working and counter/reference electrodes, with the working electrode being the anode. There was no current flow between the electrodes in the absence of sample, which was expected, as no conductive path between the electrodes was present.

The sample was introduced via a small tab of nylon sorbent material
25 formed as an extension from the nylon sorbent in the sample chamber. Liquid was wicked into the sorbent when contact was made between the sample and the sorbent tab. As the sample chamber filled and the sample made contact with the electrodes, current flowed between the electrodes. When glucose molecules in the sample came in contact with the glucose oxidase on the working electrode, the glucose molecules
30 were electrooxidized to gluconolactone. The osmium redox centers in the redox mediator then reoxidized the glucose oxidase. The osmium centers were in turn reoxidized by reaction with the working electrode. This provided a current which

was measured and simultaneously integrated by a coulometer. (EG&G Princeton Applied Research Model #173)

5 The electrochemical reaction continued until the current reached a steady state value which indicated that greater than 95% of the glucose had been electroreduced. The current curve obtained by measurement of the current at specific intervals was integrated to determine the amount of charge passed during the electrochemical reaction. These charges were then plotted versus the known glucose concentration to produce a calibration curve.

10 The sensor was tested using 0.5 μL aliquots of solutions containing known concentrations of glucose in a buffer of artificial cerebrospinal fluid or in a control serum (Baxter-Dade, Monitrol Level 1, Miami, FL) in the range of 3 to 20 mM glucose. The artificial cerebrospinal fluid was prepared as a mixture of the following salts: 126 mM NaCl, 27.5 mM NaHCO_3 , 2.4 mM KCl, 0.5 mM KH_2PO_4 , 1.1 mM $\text{CaCl}_2 \cdot 2\text{H}_2\text{O}$, and 0.5 mM Na_2SO_4 .

15 The results of the analyses are shown in Table 1 and in Figure 7. In Table 1, Q_{avg} is the average charge used to electrolyze the glucose in 3-6 identical test samples (Figure 7 graphs the charge for each of the test samples) and the 90% rise time corresponds to the amount of time required for 90% of the glucose to be electrolyzed. The data show a sensor precision of 10- 20%, indicating adequate
20 sensitivity of the sensor for low glucose concentrations, as well as in the physiologically relevant range (30 $\mu\text{g}/\text{dL}$ - 600 $\mu\text{g}/\text{dL}$).

TABLE 1
Sensor Results Using Glucose Oxidase

	Number of Samples Tested	Q_{avg} (μ C)	90% rise time (sec)
buffer only	4	9.9 ± 1.8	13 ± 6
3 mM glucose/buffer	5	17.8 ± 3.5	19 ± 5
6 mM glucose/buffer	4	49.4 ± 4.9	25 ± 3
10 mM glucose/buffer	6	96.1 ± 12.4	36 ± 17
15 mM glucose/buffer	5	205.2 ± 75.7	56 ± 23
20 mM glucose/buffer	4	255.7 ± 41.0	62 ± 17
4.2 mM glucose/serum	3	44.2 ± 4.3	44 ± 3
15.8 mM glucose/serum	3	218.2 ± 57.5	72 ± 21

5 The average measured values of glucose concentration were fit by one or more equations to provide a calibration curve. Figure 8 shows the calibration curves for the glucose/buffer data of Table 1. One of the 15.0 mM glucose measurements was omitted from these calculations because it was more than two standard deviations away from the average of the measurements. The higher glucose concentrations (10-20 mM) were fit by a linear equation. The lower glucose concentrations were fit by a second order polynomial.

10 Figure 9 shows the data of Table 1 plotted on an error grid developed by Clarke, et al. *Diabetes Care*, 5, 622-27, 1987; for the determination of the outcome of errors based on inaccurate glucose concentration determination. The graph plots "true" glucose concentration vs. measured glucose concentration, where the measured glucose concentration is determined by calculating a glucose concentration using the calibration curves of figure 8 for each data point of figure 7. Points in zone A are accurate, those in zone B are clinically acceptable, and those in zones C, D, and E lead to increasingly inappropriate and finally dangerous treatments.

20 There were 34 data points. Of those data points 91% fell in zone A, 6% in zone B, and 3 % in zone C. Only one reading was determined to be in zone

C. This reading was off-scale and is not shown in figure 9. Thus, 97% of the readings fell in the clinically acceptable zones A and B.

The total number of Os atoms was determined by reducing all of the Os and then electrooxidizing it with a glucose-free buffer in the sample chamber.

5 This resulted in a charge of $59.6 \pm 5.4 \mu\text{C}$. Comparison of this result with the glucose-free buffer result in Table 1 indicated that less than 20% of the Os is in the reduced form prior to introduction of the sample. The variability in the quantity of osmium in the reduced state is less than 5% of the total quantity of osmium present.

10

Example 2 Response of the Glucose Sensor to Interferents

A sensor constructed in the same manner as described above for Example 1 was used to determine the sensor's response to interferents. The primary
15 electrochemical interferents for blood glucose measurements are ascorbate, acetaminophen, and urate. The normal physiological or therapeutic (in the case of acetaminophen) concentration ranges of these common interferents are:

ascorbate: 0.034 - 0.114 mM

acetaminophen: 0.066 - 0.200 mM

20 urate (adult male): 0.27 - 0.47 mM

Tietz, in: *Textbook of Clinical Chemistry*, C.A. Burtis and E.R. Ashwood, eds., W.B. Saunders Co., Philadelphia 1994, pp. 2210-12.

Buffered glucose-free interferent solutions were tested with concentrations of the interferents at the high end of the physiological or therapeutic
25 ranges listed above. The injected sample volume in each case was $0.5 \mu\text{L}$. A potential of +100 mV or +200 mV was applied between the electrodes. The average charge (Q_{avg}) was calculated by subtracting an average background current obtained from a buffer-only (i.e., interferent-free) solution from an average signal recorded with interferents present. The resulting average charge was compared with the
30 signals from Table 1 for 4 mM and 10 mM glucose concentrations to determine the percent error that would result from the interferent.

TABLE 2
Interferent Response of Glucose Sensors

Solution	E (mV)	n	Q_{avg} (μ C)	Error @ 4 mM glucose	Error @ 10 mM glucose
0.114 mM ascorbate	100	4	0.4	2%	<1%
0.114 mM ascorbate	200	4	-0.5	2%	<1%
0.2 mM acetaminophen	100	4	0.1	<1%	<1%
0.2 mM acetaminophen	200	4	1.0	5%	1%
0.47 mM urate	100	4	6.0	30%	7%
0.47 mM urate	200	4	18.0	90%	21%

5 These results indicated that ascorbate and acetaminophen were not significant interferents for the glucose sensor configuration, especially for low potential measurements. However, urate provided significant interference. This interference can be minimized by calibrating the sensor response to a urate concentration of 0.37 mM, e.g., by subtracting an appropriate amount of charge as

10 determined by extrapolation from these results from all glucose measurements of the sensor. The resulting error due to a 0.10 mM variation in urate concentration (the range of urate concentration is 0.27 - 0.47 in an adult male) would be about 6% at 4 mM glucose and 100mV.

15

Example 3

Sensor with Glucose Dehydrogenase

A sensor similar to that described for Example 1 was prepared and used for this example, except that glucose oxidase was replaced by pyrroloquinoline quinone glucose dehydrogenase and a potential of only +100 mV was applied as

20 opposed to the +200 mV potential in Example 1. The results are presented in Table 3 below and graphed in Fig. 10.

TABLE 3
Sensor Results Using Glucose Dehydrogenase

	n	Q_{avg} (μC)	90% rise time (s)
buffer	4	21.7 ± 5.2	14 ± 3
3 mM glucose/buffer	4	96.9 ± 15.0	24 ± 6
6 mM glucose/buffer	4	190.6 ± 18.4	26 ± 6
10 mM glucose/buffer	4	327.8 ± 69.3	42 ± 9

5 The results indicated that the charge obtained from the glucose dehydrogenase sensor was much larger than for the comparable glucose oxidase sensor, especially for low concentrations of glucose. For 4 mM glucose concentrations the measurements obtained by the two sensors differed by a factor of five. In addition, the glucose dehydrogenase sensor operated at a lower potential, thereby reducing the effects of interferent reactions.

10

In addition, the results from Table 3 were all fit by a linear calibration curve as opposed to the results in Example 1, as shown in Fig. 10. A single linear calibration curve is greatly preferred to simplify sensor construction and operation.

Also, assuming that the interferent results from Table 2 are applicable for this sensor, all of the interferents would introduce an error of less than 7% for a 3 mM glucose solution at a potential of 100 mV.

15

Example 4 Determination of Lactate Concentration in a Fluid Stream

20

The sensor of this Example was constructed using a flow cell (BioAnalytical Systems, Inc. # MF-1025) with a glassy carbon electrode. A redox mediator was coated on the electrode of the flow cell to provide a working electrode. In this case, the redox mediator was a polymer formed by complexing poly(1-vinyl imidazole) with $\text{Os}(4,4'\text{-dimethyl-2,2'}\text{-bipyridine})_2\text{Cl}_2$ with a ratio of 1 osmium for every 15 imidazole functionalities. Lactate oxidase was cross-linked with the polymer via polyethylene glycol diglycidyl ether. The mediator was coated onto the electrode with a coverage of $500 \mu\text{g}/\text{cm}^2$ and a thickness of $5 \mu\text{m}$. The mediator was

25

covered by a polycarbonate track-etched membrane (Osmonics-Poretics #10550) to improve adherence in the flow stream. The membrane was then overlaid by a single 50 μm thick spacer gasket (BioAnalytical Systems, Inc. #MF-1062) containing a void which defined the sample chamber and corresponding measurement zone.

5 Assembly of the sensor was completed by attachment of a cell block (BioAnalytical Systems, Inc. #MF-1005) containing the reference and auxiliary electrodes of the flow cell.

The sample chamber in this case corresponded to a 50 μm thick cylinder (the thickness of the spacer gasket) in contact with a mediator-coated
10 electrode having a surface area of 0.031 cm^2 . The calculated volume of sample in the measurement zone of this sensor was approximately 0.16 μL .

The flow rate of the fluid stream was 5 $\mu\text{L}/\text{min}$. A standard three electrode potentiostat was attached to the cell leads and a potential of +200 mV was applied between the redox mediator-coated glassy carbon electrode and the reference
15 electrode. This potential was sufficient to drive the enzyme-mediated oxidation of lactate.

As the fluid stream flowed through the sensor, a steady-state current proportional to the lactate concentration was measured. At periodic intervals the fluid flow was stopped and current was allowed to flow between the electrodes until
20 approximately all of the lactate in the measurement zone was electrooxidized, as indicated by the achievement of a stabilized, steady-state current. The total charge, Q , required for lactate electrooxidation was found by integration of the differential current registered from the flow stoppage until the current reached a steady-state. The concentration was then calculated by the following equation:

25
$$[\text{lactate}] = Q/2FV \quad (4)$$

where V is the volume of sample within the measurement zone and F is Faraday's constant.

This assay was performed using lactate solutions having nominal lactate concentrations of 1.0, 5.0, and 10.0 mM. The measured concentrations for
30 the assay were 1.9, 5.4, and 8.9 mM respectively.

Example 5
Determination of the Oxidation State of Os(4,4'-dimethoxy-2,2'-
bipyridine)₂Cl^{+/+2} Complexed with poly(1-vinyl imidazole)

5
10
15
A sensor having a three electrode design was commercially obtained from Ecossensors Ltd., Long Hanborough, England, under the model name "large area disposable electrode". The sensor contained parallel and coplanar working, reference and counter electrodes. The working surface area (0.2 cm²) and counter electrodes were formed of printed carbon and the reference electrode was formed of printed Ag/AgCl. A redox mediator was coated on the carbon working electrode. The redox mediator was formed by complexation of poly(1-vinyl imidazole) with Os(4,4'-dimethoxy-2,2'-bipyridine)₂Cl₂ in a ratio of 15 imidazole groups per Os cation followed by cross linking the osmium polymer with glucose oxidase using polyethylene glycol diglycidyl ether.

20
The electrode was cured at room temperature for 24 hours. The coplanar electrode array was then immersed in a buffered electrolyte solution, and a potential of +200 mV (sufficient for conversion of Os(II) to Os(III),) was applied between the working electrode and the reference electrode.

25
Upon application of the potential, an undetectable charge of less than 1 μC was passed. Subsequent reduction and reoxidation of the redox mediator yielded a charge for conversion of all Os from Os(II) to Os(III) of 65 μC. Therefore, more than 98% of the Os cations in the redox mediator were in the desired oxidized Os(III) state.

Example 6
Determination of the Oxidation State of the Os(4,4'-dimethoxy-2,2'-
bipyridine)₂Cl^{+/+2} Complexed with poly(4-vinyl pyridine)

30
A similar experiment to that of Example 5 was conducted with the same working/counter/reference electrode configuration except that the redox mediator on the working electrode was changed to a complex of Os(4,4'-dimethoxy-

2,2'-bipyridine)₂Cl₂ with poly(4-vinyl pyridine), with 12 pyridine groups per Os cation, cross linked with glucose oxidase via polyethylene glycol diglycidyl ether.

Two sensors were constructed. The electrodes of the two sensors were cured at room temperature for 24 hours. The electrodes were then immersed in a buffered electrolyte solution and a potential of +200 mV was applied between the working and reference electrodes.

Upon application of the potential to the electrodes, a charge of 2.5 μC and 3.8 μC was passed in the two sensors, respectively. Subsequent reduction and reoxidation of the redox mediators yielded oxidation charges of 27.9 μC and 28.0 μC , respectively. Therefore, the sensors originally contained 91% and 86% of the Os cations in the desirable oxidized Os(III) state.

Example 7 Optical Sensor

An optical sensor is constructed by applying a film of redox polymer with crosslinked enzyme onto a light-transparent support such as a glass slide. The quantity of redox mediator is equal to or greater than (in a stoichiometric sense) the maximum quantity of analyte expected to fill the measurement zone. The spacer material, sorbent and facing support are securely clamped. The sample chamber is adapted to transmit light through the assembled sensor to an optical density detector or to a fluorescence detector. As sample fills the sample chamber and the redox mediator is oxidized, changes in the absorption, transmission, reflection or fluorescence of the redox mediator in the chamber are correlated to the amount of glucose in the sample.

Example 8 Blood Volumes from Upper Arm Lancet Sticks

The forearm of a single individual was pierced with a lancet multiple times in order to determine the reproducibility of blood volumes obtained by this method. Despite more than thirty lancet sticks in the anterior portion of each

forearm and the dorsal region of the left forearm, the individual identified each stick as virtually painless.

The forearm was pierced with a Payless Color Lancet. The blood from each stick was collected using a 1 μ L capillary tube, and the volume was
 5 determined by measuring the length of the blood column. The volumes obtained from each stick are shown below in Table 4.

Table 4
Volume of Lancet Sticks

	Left Anterior Forearm, (nL)	Right Anterior Forearm, (nL)	Left Dorsal Forearm, (nL)
1	180	190	180
2	250	180	300
3	170	120	310
4	150	100	300
5	100	210	60
6	50	140	380
7	90	120	220
8	130	140	200
9	120	100	380
10		100	320
11			260
12			250
13			280
14			260
Avg.	138 \pm 58 nL	140 \pm 40 nL	264 \pm 83 nL

10 The invention has been described with reference to various specific and preferred embodiments and techniques. However, it will be apparent to one of ordinary skill in the art that many variations and modifications may be made while remaining within the spirit and scope of the invention.

All publications and patent applications in this specification are
 15 indicative of the level of ordinary skill in the art to which this invention pertains. All publications and patent applications are herein incorporated by reference to the same extent as if each individual publication or patent application was specifically and individually indicated by reference.

WE CLAIM:

1. A method for determining a concentration of an analyte in a sample, comprising the steps of:
 - contacting a sample with an electrochemical sensor comprising:
 - a facing electrode pair comprising a working electrode and a counter electrode; and
 - a sample chamber for holding the sample in electrolytic contact with the working electrode, the sample chamber comprising a measurement zone positioned between the working and counter electrodes, wherein the measurement zone is sized to contain a volume of less than about 1 μL of sample; and
 - determining the concentration of the analyte in the sample by coulometry.
2. The method of claim 1, wherein the measurement zone is sized to contain a volume of less than about 0.5 μL of sample.
3. The method of claim 2, wherein the measurement zone is sized to contain a volume of less than about 0.2 μL of sample.
4. The method of claim 3, wherein the measurement zone is sized to contain a volume of less than about 0.1 μL of sample.
5. The method of claim 1, wherein the sample chamber is sized to contain a volume of less than about 1 μL of sample.
6. The method of claim 5, wherein the sample chamber is sized to contain a volume of less than about 0.5 μL of sample.
7. The method of claim 6, wherein the sample chamber is sized to contain a volume of less than about 0.2 μL of sample.

8. The method of claim 1, wherein the step of determining the concentration of the analyte comprises:

electrolyzing at least 90% of analyte present in the measurement zone by applying a potential across the working and counter electrodes;
determining an electrical charge used to electrolyze the analyte; and
correlating the electrical charge with the concentration of the analyte in the sample.

9. The method of claim 8, wherein at least 90% of the analyte is electrolyzed in less than about 5 minutes.

10. The method of claim 9, wherein at least 90% of the analyte is electrolyzed in less than about 1 minute.

11. The method of claim 8, wherein the step of determining an electrical charge comprises the steps of:

measuring a current generated at the working electrode at two or more times as the analyte is electrolyzed; and
integrating the measured currents over time to obtain the electrical charge used to electrolyze the analyte.

12. The method of claim 1, wherein the step of determining the concentration of the analyte by coulometry comprises the steps of:

electrolyzing a portion of the analyte by applying a potential across the working and the counter electrode;
measuring a current generated at the working electrode at two or more times during the electrolysis;
extrapolating a current curve based on the measured currents;
integrating the current curve over time to obtain an electrical charge necessary to electrolyze at least 90% of the analyte; and

correlating the electrical charge with the concentration of the analyte in the sample.

13. The method of claim 1, wherein the sensor further comprises a non-leachable enzyme on the working electrode.

14. The method of claim 13, wherein the enzyme is immobilized on the working electrode.

15. The method of claim 1, wherein the sensor further comprises a non-leachable redox mediator on the working electrode.

16. The method of claim 15, wherein the redox mediator is immobilized on the working electrode.

17. The method of claim 15, wherein the redox mediator comprises a polymer and a redox species ionically, covalently, or coordinatively bound to the polymer.

18. The method of claim 17, wherein the redox species is coordinatively bound to the polymer.

19. The method of claim 15, wherein the redox mediator comprises an air-oxidizable redox mediator.

20. The method of claim 19, wherein the air-oxidizable redox mediator comprises $\text{Os}[4,4'\text{-dimethoxy-2,2'\text{-bipyridine}}]_2\text{Cl}^{+/+2}$ or $\text{Os}[4,7\text{-dimethoxy-1,10-phenanthroline}]_2\text{Cl}^{+/+2}$ complexed with poly(1-vinyl imidazole) or poly(4-vinylpyridine).

21. The method of claim 15, wherein at least 90% of the redox mediator is in an oxidized state prior to introduction of the sample in the sensor.

22. The method of claim 15, wherein the sensor further comprises a non-leachable second electron transfer agent on the working electrode.
23. The method of claim 22, wherein the second electron transfer agent is immobilized on the working electrode.
24. The method of claim 22, wherein the second electron transfer agent comprises an enzyme.
25. The method of claim 24, wherein the analyte is glucose.
26. The method of claim 25, wherein the enzyme is a glucose oxidase.
27. The method of claim 1, wherein the sensor further comprises sorbent material disposed in the measurement zone.
28. The method of claim 27, wherein the step of contacting the sample with an electrochemical sensor further comprises contacting the sample with the sorbent material to wick the sample into the measurement zone.
29. The method of claim 1, wherein the working electrode and counter electrode have a separation distance of less than about 0.2 mm.
30. The method of claim 29, wherein the separation distance is less than about 0.1 mm.
31. The method of claim 30, wherein the separation distance is less than about 0.05 mm.
32. The method of claim 1, wherein the sensor comprises two or more facing electrode pairs.

33. A method of determining the concentration of an analyte in a sample, comprising the steps of:
- contacting a sample with an electrochemical sensor, wherein the sensor comprises a working electrode, a non-leachable redox mediator on the working electrode, and a sample chamber sized to contain a volume of less than about 1 μL of sample in electrolytic contact with the working electrode; and
 - determining the concentration of the analyte in the sample by coulometry.
34. The method of claim 33, wherein the sample chamber is sized to contain a volume of less than about 0.5 μL of sample.
35. The method of claim 34, wherein the sample chamber is sized to contain a volume of less than about 0.2 μL of sample.
36. The method of claim 33, wherein the redox mediator is immobilized on the working electrode.
37. The method of claim 33, wherein the sensor further comprises a non-leachable second electron transfer agent on the working electrode.
38. The method of claim 37, wherein the second electron transfer agent is immobilized on the working electrode.
39. The method of claim 37, wherein the second electron transfer agent comprises an enzyme.
40. The method of claim 33, wherein the sensor further comprises a sorbent material within the sample chamber to reduce the volume of sample that the sample chamber is sized to hold.
41. The method of claim 33, wherein the redox mediator comprises a transition metal complex.

42. The method of claim 41, wherein the transition metal complex is an osmium, ruthenium, iron, or cobalt complex.
43. The method of claim 42, wherein the transition metal complex comprises an osmium complex.
44. The method of claim 43, wherein the osmium complex comprises osmium complexed with at least one ligand having a nitrogen-containing heterocycle.
45. The method of claim 44, wherein the ligand having a nitrogen-containing heterocycle comprises 2,2'-bipyridine, 1,10-phenanthroline, or a derivative thereof.
46. The method of claim 45, wherein the ligand having a nitrogen-containing heterocycle comprises a mono-, di-, or polyalkoxy derivative of 2,2'-bipyridine or 1,10-phenanthroline, wherein the carbon to oxygen ratio of the alkoxy functional groups is sufficient to retain solubility of the transition metal complex in water prior to crosslinking.
47. The method of claim 45, wherein the nitrogen-containing heterocycle comprises 2,2'-bipyridine, 4,4'-dimethyl-2,2'-bipyridine, 4,4'-dialkoxy-2,2'-bipyridine, 1,10-phenanthroline, 4,7-dimethyl-1,10-phenanthroline, or 4,7-dialkoxy-1,10-phenanthroline, wherein the carbon to oxygen ratio of the alkoxy functional groups is sufficient to retain solubility of the transition metal complex in water prior to crosslinking.
48. The method of claim 43, wherein the osmium complex comprises osmium complexed with a polymeric ligand.
49. The method of claim 48, wherein the polymeric ligand comprises a nitrogen-containing heterocycle.

50. The method of claim 49, wherein the polymer comprises poly(4-vinyl pyridine) or poly(1-vinyl imidazole).
51. An electrochemical sensor for determining the concentration of an analyte in a sample, the sensor comprising:
a facing electrode pair comprising a working electrode and a counter electrode;
a non-leachable redox mediator on the working electrode; and
a measurement zone positioned between the working electrode and counter electrode, wherein the measurement zone is sized to contain a volume of less than about 1 μL of sample.
52. The sensor of claim 51, wherein the measurement zone is sized to contain a volume of less than about 0.5 μL of sample.
53. The sensor of claim 52, wherein the measurement zone is sized to contain a volume of less than about 0.2 μL of sample.
54. The sensor of claim 53, wherein the measurement zone is sized to contain a volume of less than about 0.1 μL of sample.
55. The sensor of claim 51, wherein the redox mediator is immobilized on the working electrode.
56. The sensor of claim 51, wherein the redox mediator is an air-oxidizable redox mediator.
57. An electrochemical sensor comprising:
two or more facing electrode pairs, each electrode pair comprising a working electrode, a counter electrode and a measurement zone disposed approximately between the working and counter electrodes, wherein the measurement zone is sized to hold less than about 1 μL of sample; and

non-leachable redox mediator on the working electrode of at least one of the electrode pairs.

58. The sensor of claim 57, wherein the redox mediator is immobilized on the working electrode of at least one of the electrode pairs.

59. The sensor of claim 57, wherein the measurement zone of at least one of the electrode pairs is sized to hold less than about 0.5 μL of sample.

60. The sensor of claim 59, wherein the measurement zone of at least one of the electrode pairs is sized to hold less than about 0.2 μL of sample.

61. The sensor of claim 60, wherein the measurement zone of at least one of the electrode pairs is sized to hold less than about 0.1 μL of sample.

62. The sensor of claim 57, wherein at least one electrode pair comprises a working electrode including non-leachable enzyme and redox mediator, and wherein at least one electrode pair comprises a working electrode including non-leachable redox mediator in the absence of the enzyme.

63. The sensor of claim 62, further comprising a third electrode pair having no redox mediator or enzyme on the working electrode.

64. The sensor of claim 57, further comprising sorbent material disposed in the measurement zone of at least one of the electrode pairs.

65. The sensor of claim 57, wherein the redox mediator is an air-oxidizable redox mediator.

66. An electrochemical sensor for determining the concentration of an analyte in a sample, the sensor comprising:

a facing electrode pair comprising a working electrode and a counter electrode;

a measurement zone positioned between the working electrode and counter electrode; and

sorbent material disposed at least partially within the measurement zone to reduce the volume of sample needed to fill the measurement zone;

wherein the measurement zone is sized to contain a volume of less than about 1 μL of sample.

67. The sensor of claim 66, wherein the measurement zone is sized to contain a volume of less than about 0.5 μL of sample.

68. The sensor of claim 67, wherein the measurement zone is sized to contain a volume of less than about 0.2 μL of sample.

69. The sensor of claim 68, wherein the measurement zone is sized to contain a volume of less than about 0.1 μL of sample.

70. The sensor of claim 66, wherein the sensor further comprises non-leachable redox mediator on the working electrode.

71. The sensor of claim 70, wherein the redox mediator is immobilized on the working electrode.

72. The sensor of claim 66, wherein the sorbent material has a void volume of between about 5% and 50% of the total volume of the sorbent material.

73. The sensor of claim 72, wherein the void volume is about 10% to about 25% of the total volume of the sorbent material.

74. An electrochemical sensor for determining the concentration of an analyte in a sample, the sensor comprising:

a working electrode;
a non-leachable redox mediator on the working electrode;
a sample chamber for holding the sample in electrolytic contact with the working electrode; and
sorbent material disposed within the sample chamber;
wherein the sample chamber is sized to contain a volume of less than about 1 μL of sample.

75. The sensor of claim 74, wherein the sample chamber is sized to contain a volume of less than about 0.5 μL of sample.

76. The sensor of claim 75, wherein the sample chamber is sized to contain a volume of less than about 0.2 μL of sample.

77. A method for determining the concentration of an analyte in a sample, comprising the steps of:
contacting the sample with an electrochemical sensor; the sensor comprising:
an electrode pair comprising a working electrode and a counter electrode;
a sample chamber for holding the sample in electrolytic contact with the working electrode; and
a sorbent disposed within the sample chamber;
wherein the sample chamber is sized to hold less than about 1 μL of sample; and
determining the concentration of the analyte by coulometry.

78. The method of claim 77, wherein the method further comprises wicking the sample into the sample chamber using the sorbent material.

79. The method of claim 77, wherein the electrode pair is a facing electrode pair.

80. A sensor for the determination of the concentration of an analyte in a sample having a volume of less than about 1 μ L, comprising:

a support; and

an air-oxidizable redox mediator coated on the support to form a working surface for contacting sample;

wherein, at least 90% of the air-oxidizable redox mediator is in an oxidized state prior to introduction of sample.

81. The sensor of claim 80, wherein the air-oxidizable redox mediator is immobilized on the support.

82. A method for determining a concentration of an analyte in a sample, comprising the steps of:

contacting the sample with a sensor comprising a support; and an air-oxidizable redox mediator coated on the support to form a working surface, wherein, at least 90% of the air-oxidizable redox mediator is in an oxidized state prior to introduction of a sample; and

correlating the concentration of the analyte in the sample to a change in oxidation state of the redox mediator in the presence of analyte.

83. The method of claim 82, wherein the sensor is an optical sensor.

84. The method of claim 83, wherein the step of correlating the concentration of the analyte comprises:

irradiating the redox mediator with light;

measuring the response of the redox mediator to irradiation by light; and

correlating the concentration of the analyte to the measured response of the redox mediator.

85. The method of claim 84, wherein the step of measuring the response of the redox mediator to irradiation by light comprises measuring the absorption of the irradiated light by the redox mediator.

86. The method of claim 84, wherein the step of measuring the response of the redox mediator to irradiation by light comprises measuring the transmittance of the irradiated light by the redox mediator.

87. The method of claim 84, wherein the step of measuring the response of the redox mediator to irradiation by light comprises measuring the fluorescence of the redox mediator after irradiation by light.

88. The method of claim 84, wherein the step of measuring the response of the redox mediator to irradiation by light comprises measuring the reflection of light by the redox mediator.

89. The method of claim 82, wherein the sensor is an electrochemical sensor.

90. The method of claim 89, wherein the step of correlating the concentration of the analyte comprises:

applying an electrical potential across the redox mediator;

measuring a current at one or more intervals, the current being generated in response to the electrolysis of the redox mediator in the presence of the analyte; and

correlating the concentration of the analyte to the measured current.

91. The method of claim 82, wherein the redox mediator comprises a transition metal complex.

92. The method of claim 91, wherein the transition metal complex comprises an osmium complex.

93. The method of claim 92, wherein the osmium complex comprises osmium complexed with at least one ligand having a nitrogen-containing heterocycle.

94. The method of claim 93, wherein the ligand having a nitrogen-containing heterocycle comprises 2,2'-bipyridine, 1,10-phenanthroline, or a derivative thereof.

95. The method of claim 94, wherein the ligand having a nitrogen-containing heterocycle comprises a mono-, di-, or polyalkoxy derivative of 2,2'-bipyridine or 1,10-phenanthroline, wherein the carbon to oxygen ratio of the alkoxy functional groups is sufficient to retain solubility of the transition metal complex in water prior to crosslinking.

96. The method of claim 95, wherein the nitrogen-containing heterocycle comprises 4,4'-dialkoxy-2,2'-bipyridine or 4,7-dialkoxy-1,10-phenanthroline, wherein the carbon to oxygen ratio of the alkoxy functional groups is sufficient to retain solubility of the transition metal complex in water prior to crosslinking.

97. The method of claim 96, wherein the nitrogen-containing heterocycle comprises 4,4'-dimethoxy-2,2'-bipyridine or 4,7-dimethoxy-1,10-phenanthroline.

98. The method of claim 92, wherein the osmium complex comprises osmium complexed with a polymeric ligand.

99. The method of claim 98, wherein the polymeric ligand comprises a nitrogen-containing heterocycle.

100. The method of claim 99, wherein the polymer comprises poly(4-vinyl pyridine) or poly(1-vinyl imidazole).

101. The sensor of claim 100, wherein the redox mediator comprises $\text{Os}[4,4'\text{-dimethoxy-2,2'-bipyridine}]_2\text{Cl}^{+/+2}$ or $\text{Os}[4,7\text{-dimethoxy-1,10-phenanthroline}]_2\text{Cl}^{+/+2}$ complexed with poly(1-vinyl imidazole).

102. The sensor of claim 82, wherein the sensor further comprises a second electron transfer agent coated on the support and in contact with the redox mediator.

103. The sensor of claim 102, wherein the second electron transfer agent is an enzyme.
104. The sensor of claim 102, wherein the second electron transfer agent is immobilized on the support.
105. The sensor of claim 82, wherein the air-oxidizable redox mediator is immobilized on the support.
106. A method for measuring analyte in a patient sample, the method comprising:
contacting the patient with an analyte measuring device, the device comprising:
sample acquisition means for producing a patient sample; and
an electrochemical sensor for measuring analyte in the sample;
wherein the electrochemical sensor comprises:
a facing electrode pair, comprising a working electrode and a counter electrode; and
a measurement zone positioned between the working electrode and counter electrode, wherein the measurement zone is sized to contain a volume of less than about 1 μL of sample;
acquiring a sample using the sample acquisition means;
transporting a portion of the sample to the measurement zone of the electrochemical sensor; and
determining the concentration of the analyte in the sample by coulometry.
107. The method of claim 106, wherein the sample acquisition means comprises a skin-piercing member and the step of acquiring a sample comprises piercing the patient's skin to produce a sample.
108. The method of claim 107, wherein the skin piercing member comprises a lancet.

109. The method of claim 106, wherein the electrochemical sensor further comprises a sorbent material disposed within the measurement zone of the sensor.
110. The method of claim 109, wherein said transporting comprises:
wicking the sample into the measurement zone using the sorbent material.
111. The method of claim 106, wherein the measurement zone is sized to contain a volume of less than about 0.5 μL of sample.
112. The method of claim 111, wherein the measurement zone is sized to contain a volume of less than about 0.2 μL of sample.
113. The sensor of claim 112, wherein the measurement zone is sized to contain a volume of less than about 0.1 μL of sample.
114. The method of claim 106, wherein the sensor further comprises a non-leachable redox mediator.
115. The method of claim 114, wherein the redox mediator is an air-oxidizable redox mediator.
116. A method for measuring analyte in a patient sample, the method comprising:
contacting the patient with an analyte measuring device, the device comprising:
sample acquisition means for producing a patient sample; and
an electrochemical sensor for measuring analyte in the sample;
wherein the electrochemical sensor comprises:
a working electrode;
non-leachable redox mediator on the working electrode; and

a sample chamber for holding the sample in electrolytic contact with the working electrode, wherein the sample chamber is sized to contain a volume of less than about 1 μL of sample; acquiring a sample using the sample acquisition means; transporting a portion of the sample to the sample chamber of the electrochemical sensor; and determining the concentration of the analyte in the sample by coulometry.

117. An analyte measurement device comprising:
sample acquisition means for producing a patient sample;
an electrochemical sensor comprising:
a facing electrode pair comprising a working electrode and a counter electrode;
a non-leachable redox mediator on the working electrode; and
a measurement zone positioned between the working electrode and counter electrode;
wherein the measurement zone is sized to contain a volume of less than about 1 μL of sample; and
transport means for transporting the sample produced by the sample acquisition means to the measurement zone of the sensor.
118. The device of claim 117, wherein the sample acquisition means comprises a skin-piercing member.
119. The device of claim 118, wherein the skin-piercing member comprises a lancet.
120. The device of claim 117, wherein the redox mediator is immobilized on the working electrode.
121. The device of claim 117, wherein the redox mediator is an air-oxidizable redox mediator.

122. The device of claim 117, wherein the transport means comprises a wicking material, a capillary chamber, or a pump.
123. An analyte measurement device comprising:
sample acquisition means for producing a patient sample; and
an electrochemical sensor coupled to the sample acquisition means,
comprising:
a facing electrode pair comprising a working electrode and a counter electrode;
a measurement zone positioned between the working electrode and counter electrode; and
sorbent material disposed within the measurement zone;
wherein the measurement zone is sized to contain a volume of less than about 1 μl of sample; and
transport means for transporting the sample produced by the sample acquisition means to the measurement zone of the sensor.
124. The device of claim 123, wherein the transport means is the sorbent material.
125. A method for determination of a concentration of an analyte in a sample, the method comprising the steps of:
contacting a sample with an electrochemical sensor comprising:
first and second electrode pairs, each pair comprising a working electrode, and a sample chamber for holding the sample in electrolytic contact with the working electrode, the sample chamber sized to contain a volume of less about 1 μL of sample; wherein said first electrode pair includes a non-leachable redox mediator and a non-leachable enzyme on the working electrode; and wherein said second electrode pair includes non-leachable redox mediator on the working electrode in the absence of enzyme;

measuring substantially simultaneously, and at two or more times, a first current generated at the first electrode pair and a second current generated at the second electrode pair; and

integrating the measured first currents over time to obtain a first charge;

integrating the measured second currents over time to obtain a second charge;

subtracting the second charge from the first charge to obtain a noise-reduced charge; and

correlating the concentration of the analyte to the noise-reduced charge.

126. The method of claim 125, wherein the first and second electrode pairs are facing electrode pairs and further comprise a counter electrode and a measurement zone between the working electrode and counter electrode, the measurement zone sized to contain a volume of less than about 1 μL of sample.

127. A method for determining a concentration of an analyte in a sample, the method comprising the steps of:

providing an electrochemical sensor, the sensor having one or more facing electrode pairs, each electrode pair comprising a working electrode, a counter electrode, and a measurement zone between the working electrode and the counter electrode, the measurement zone having a volume of less than about 1 μL , wherein the measurement zones of the one or more electrode pairs have approximately equal volumes, and wherein at least one of the electrode pairs further comprises redox mediator on its working electrode;

measuring a capacitance of at least one of the electrode pairs;

calculating the volume of the measurement zone from the capacitance measurement;

contacting the sample with the sensor; and

determining the concentration of the analyte in the sample by coulometry.

128. The method of claim 127, wherein the redox mediator is a non-leachable redox mediator.

129. A method of storing and packaging an analytical sensor comprising the steps of:

packaging an analytical sensor in an atmosphere containing molecular oxygen, the sensor comprising an air-oxidizable redox mediator.

130. The method of claim 129, wherein greater than 90% of the redox mediator is in an oxidized state after being stored for more than one month.

131. A method for determining a concentration of an analyte in a sample comprising the steps of:

contacting the sample with an electrochemical sensor, the sensor comprising a working electrode and a non-leachable redox mediator on the working electrode, wherein the molar amount of redox mediator in a reduced form prior to introduction of the sample is less than, on a stoichiometric basis, 5% of the expected molar amount of the analyte to be electrolyzed;

electrolyzing less than about 1 μL of sample; and

determining the concentration of the analyte in the sample by coulometry.

132. A method of determining a concentration of an analyte in a sample comprising the steps of:

contacting the sample with an electrochemical sensor comprising a working electrode, a counter electrode, and a measurement zone bounded on at least two sides by the working and the counter electrodes, wherein the measurement zone is sized to contain less than about 1 μL of sample; and

determining the concentration of the analyte in the sample by coulometry.

133. The electrochemical sensor of claim 51, wherein the working electrode comprises a first arm and the counter electrode comprises a second arm, a portion of the first arm overlapping a portion of the second arm, the measurement zone comprising a region between the overlapping portions of the first and second arms.

134. The electrochemical sensor of claim 133, wherein the first arm has an extra length and the overlapping portion of the first arm has a width, wherein a ratio of the extra length of the first arm to the width of the overlapping portion of the first arm ranges from 0.1:1 to 50:1.

135. The electrochemical sensor of claim 134, wherein the ratio ranges from 1:1 to 15:1.

136. The electrochemical sensor of claim 134, wherein the ratio ranges from 4:1 to 10:1.

137. The electrochemical sensor of claim 133, wherein the first and second arms intersect at an angle greater than 0 degrees.

138. The electrochemical sensor of claim 74, wherein the sorbent material comprises a powdered material disposed on the working electrode.

139. The electrochemical sensor of claim 51, wherein the facing electrode pair comprises a base material having a recess and at least one of the working electrode and the counter electrode disposed in the recess.

140. The electrochemical sensor of claim 51, further comprising a filler material disposed in the measurement zone to decrease a volume of the measurement zone available for the sample.

141. The electrochemical sensor of claim 140, wherein the filler material is hydrophilic.

142. The electrochemical sensor of claim 57, wherein the two or more facing electrode pairs comprises a first electrode pair responsive to a first analyte and a second electrode pair responsive to a second analyte.

143. The method of claim 33, wherein the sensor comprises at least two working electrodes, each working electrode having an associated measurement zone.

144. The method of claim 143, wherein determining the concentration of the analyte comprises averaging measurements from the at least two working electrodes.

145. The method of claim 144, wherein determining the concentration of the analyte further comprises eliminating measurements which exceed a threshold value.

146. The method of claim 145, wherein determining the concentration of the analyte further comprises reaveraging the measurements without the eliminated measurements.

1/12

FIG. 1

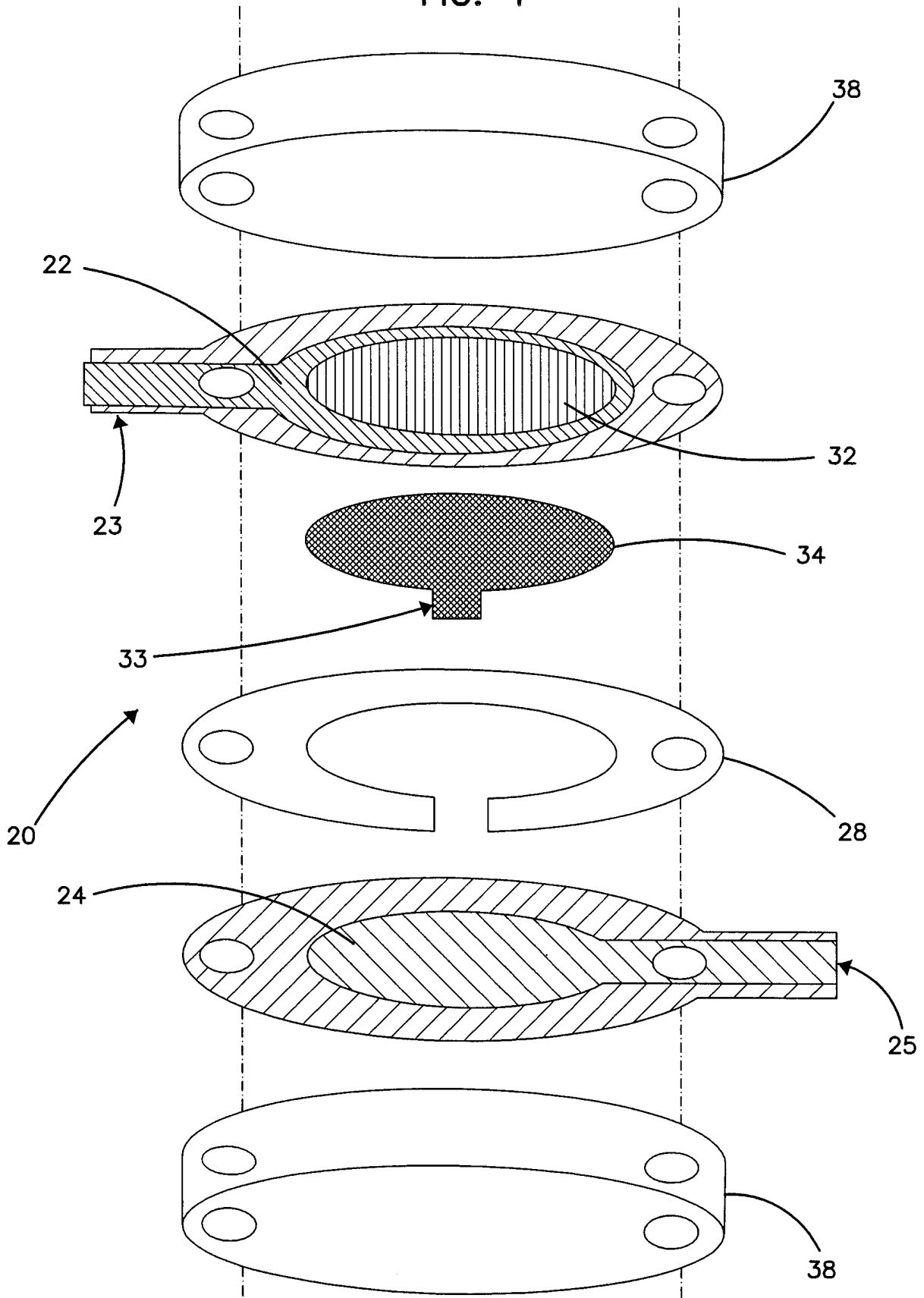

2/12

FIG. 2

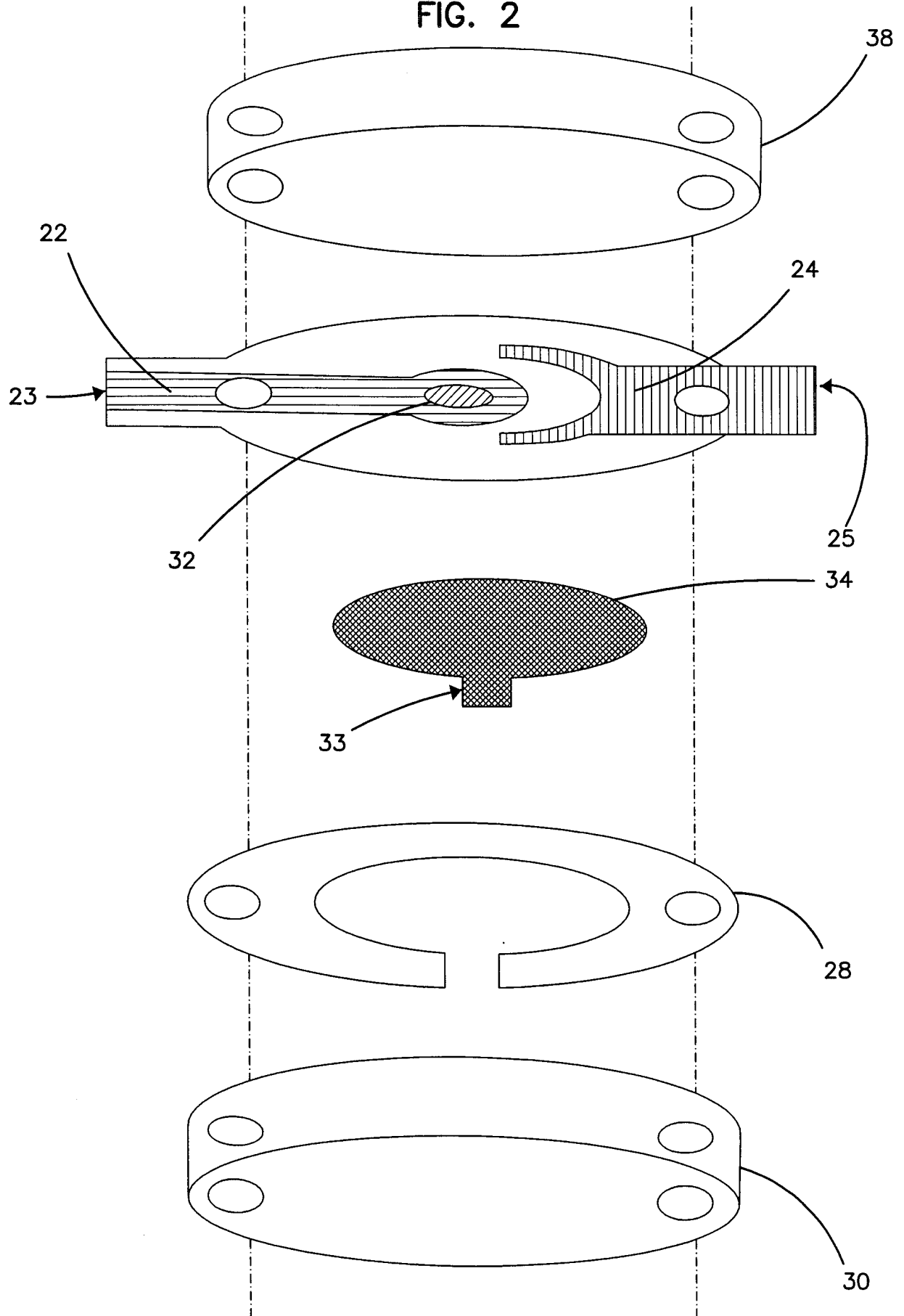

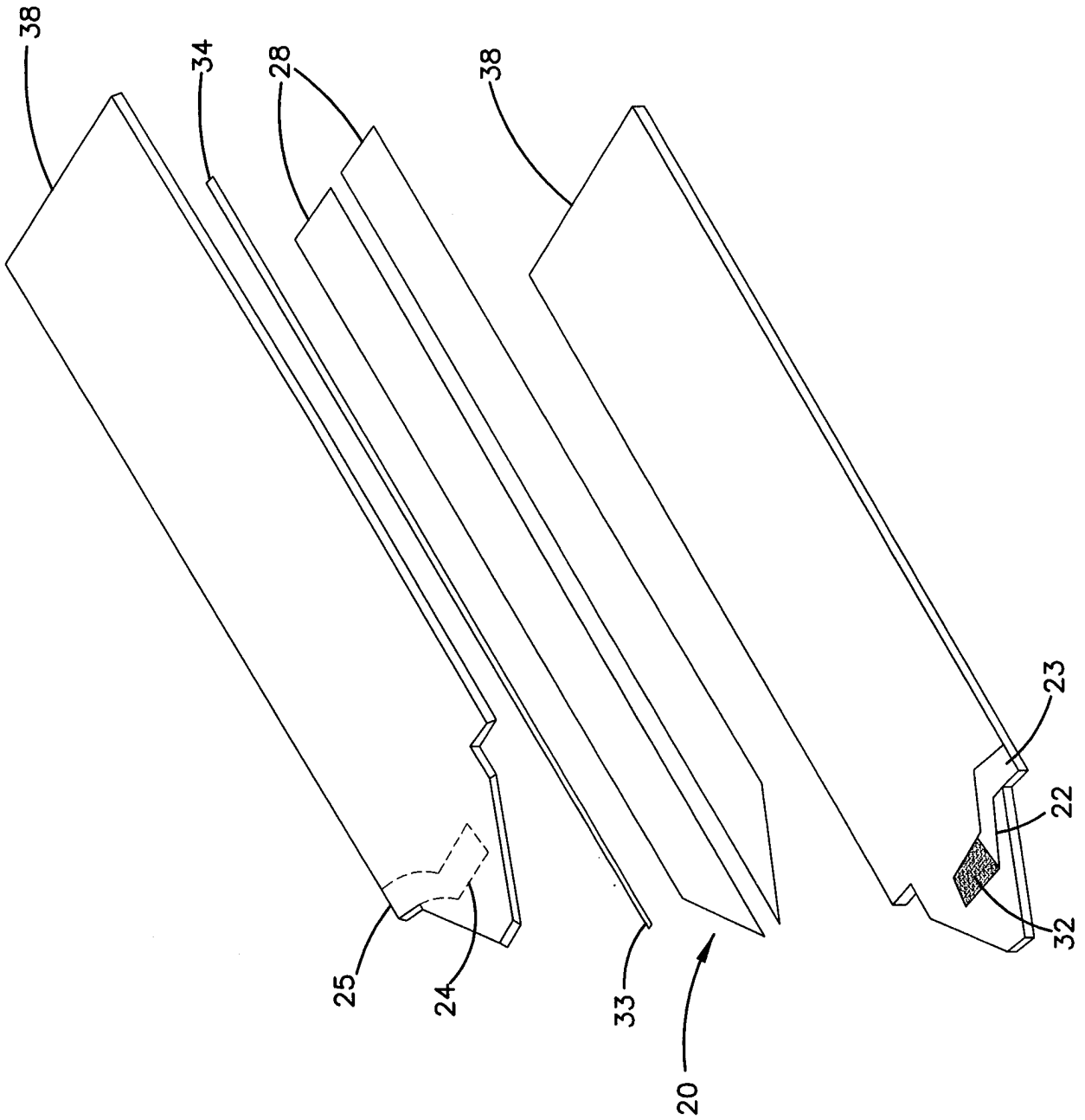
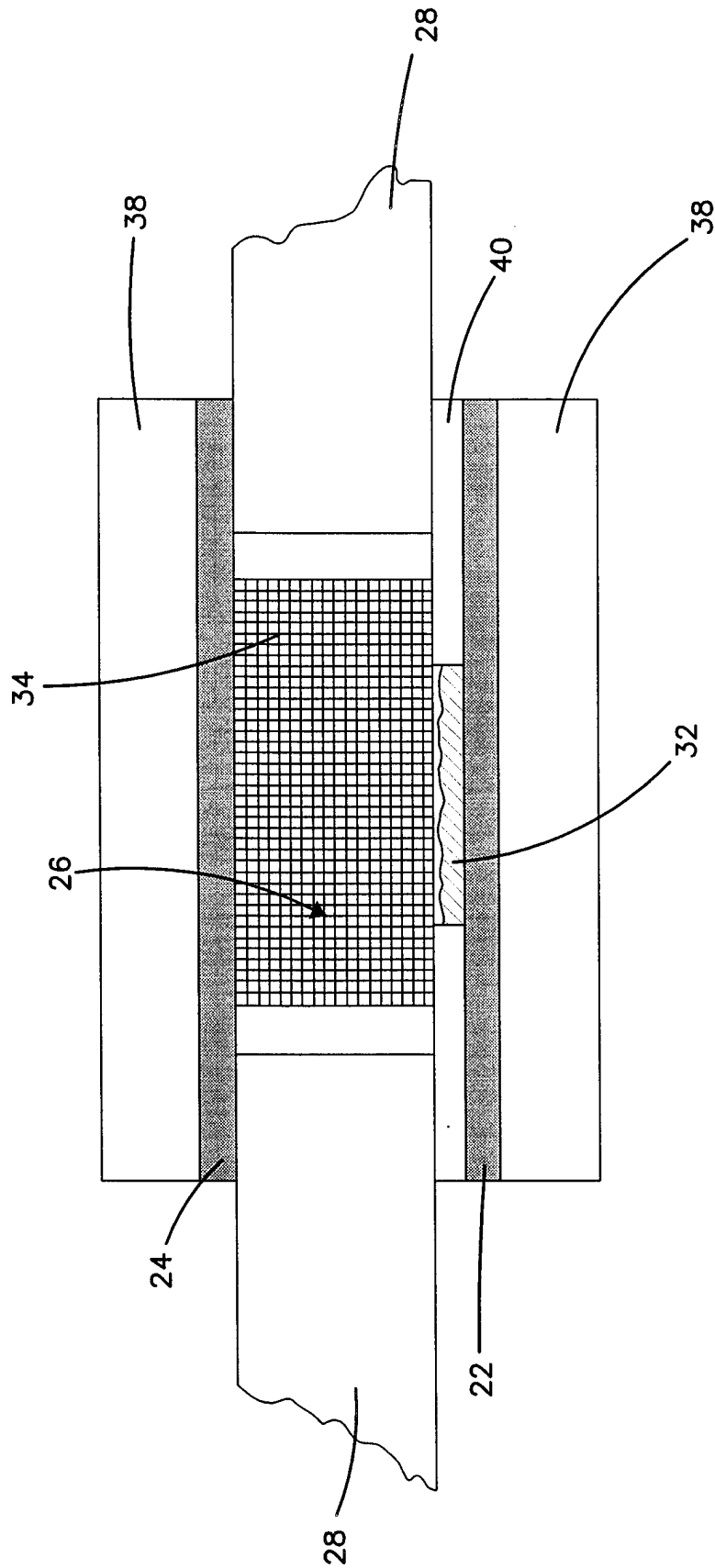

FIG. 3

SUBSTITUTE SHEET (RULE 26)



SUBSTITUTE SHEET (RULE 26)

FIG. 4

FIG. 5

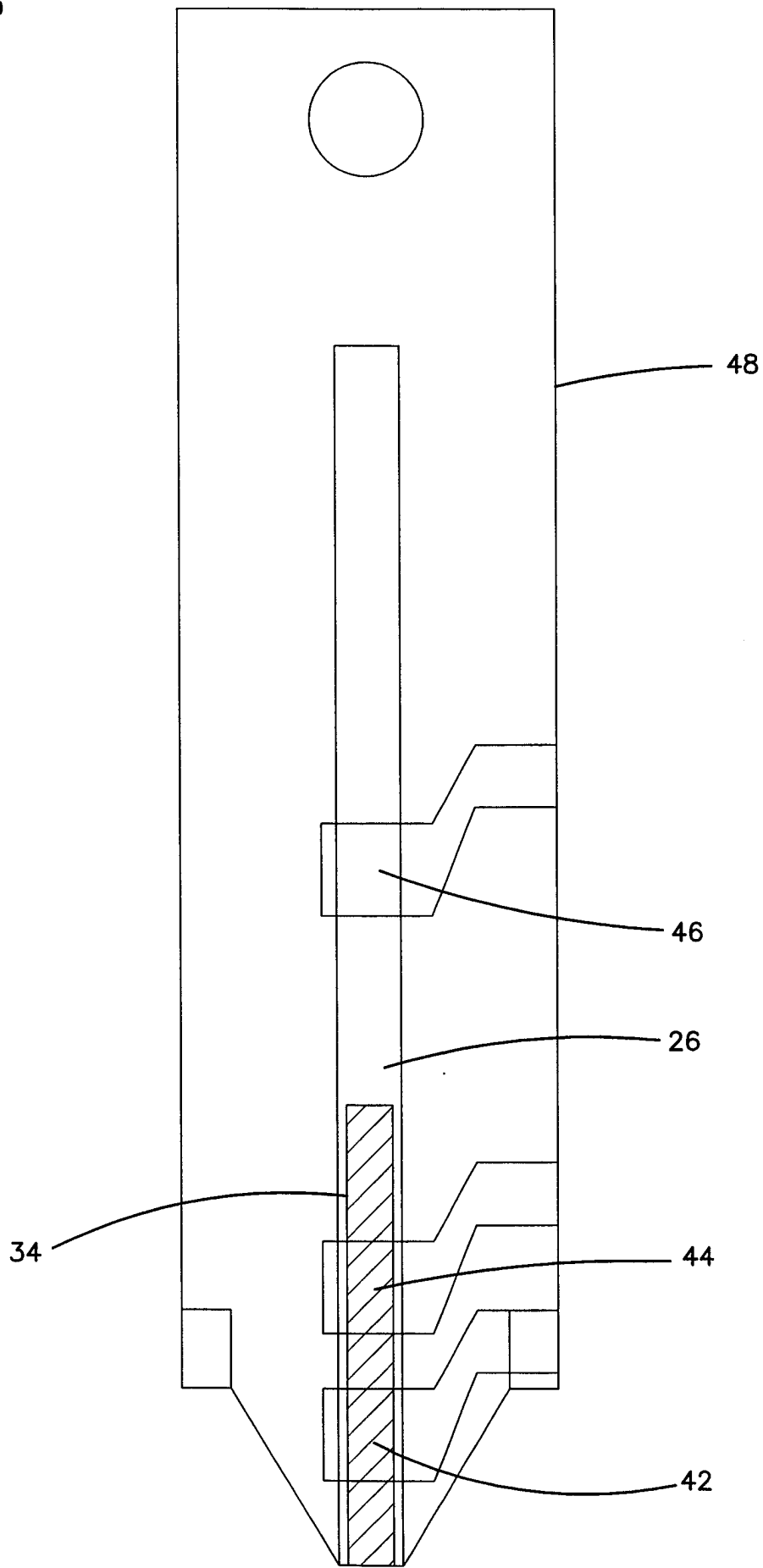

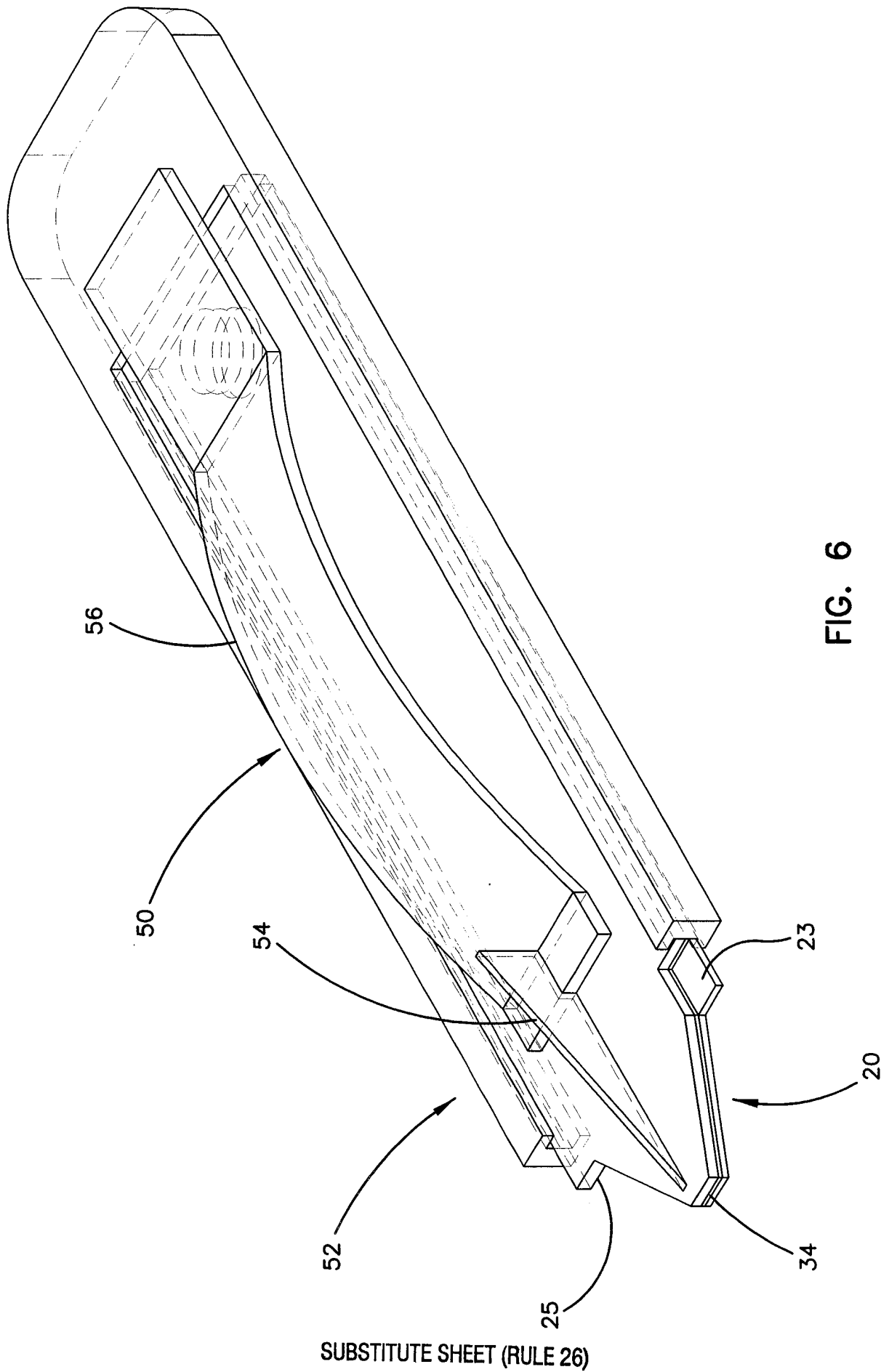

7/12

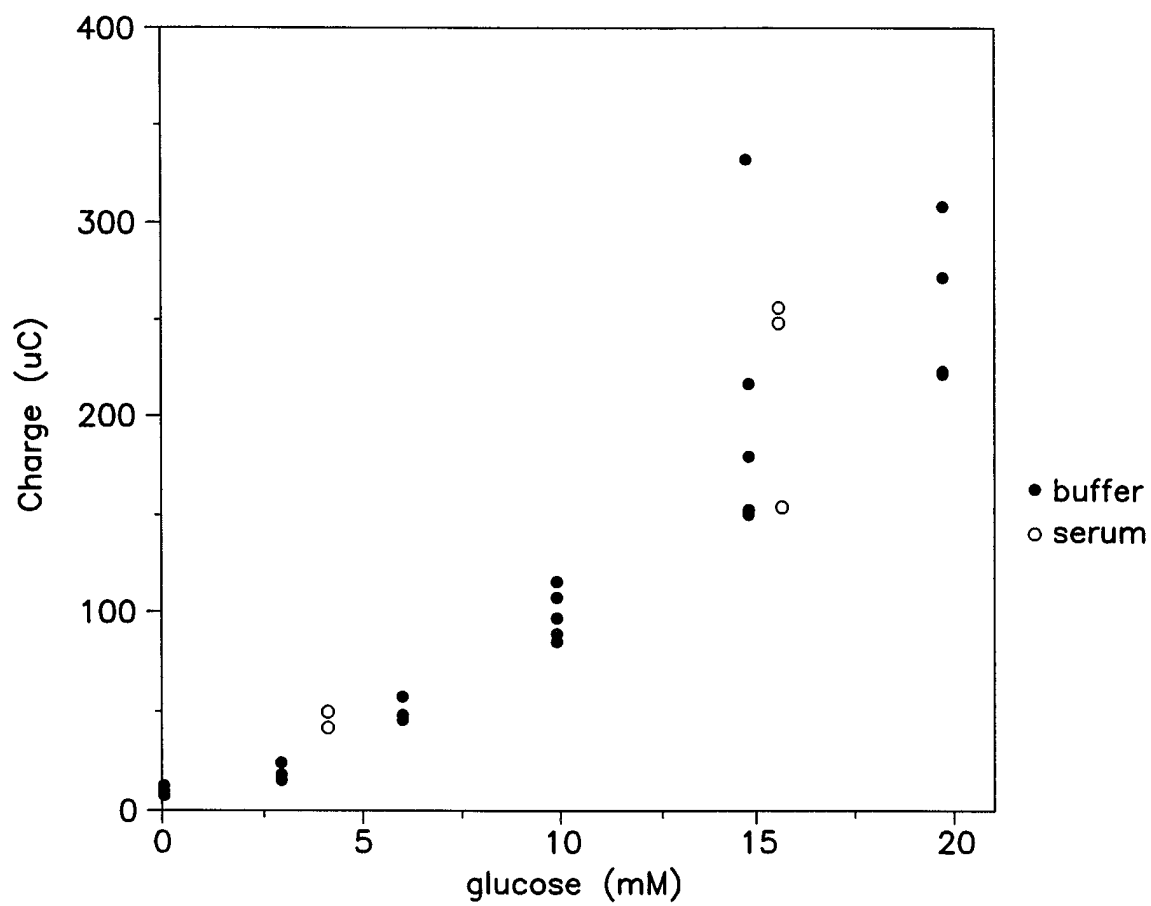

FIG. 7

8/12

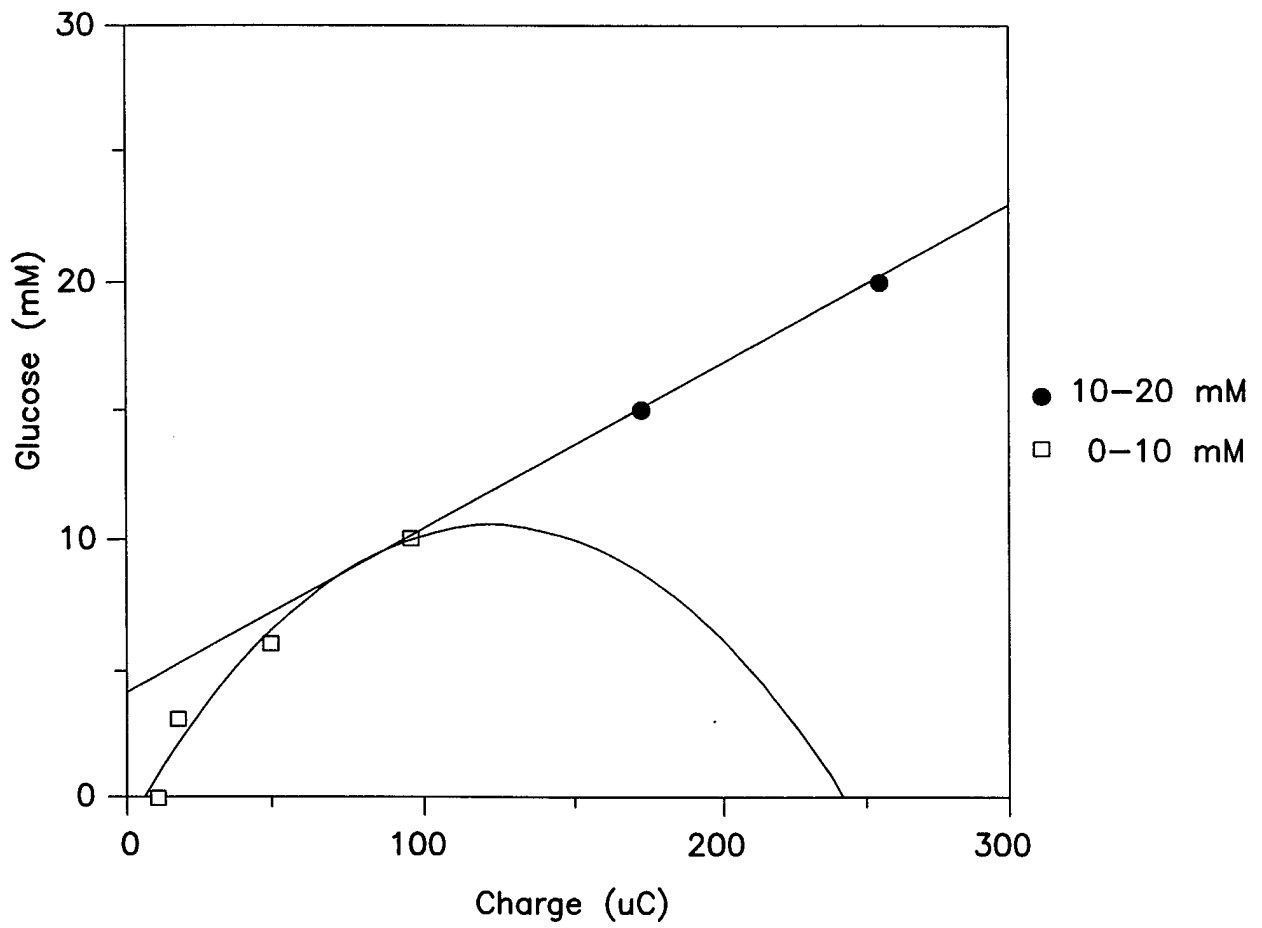

FIG. 8

10/12

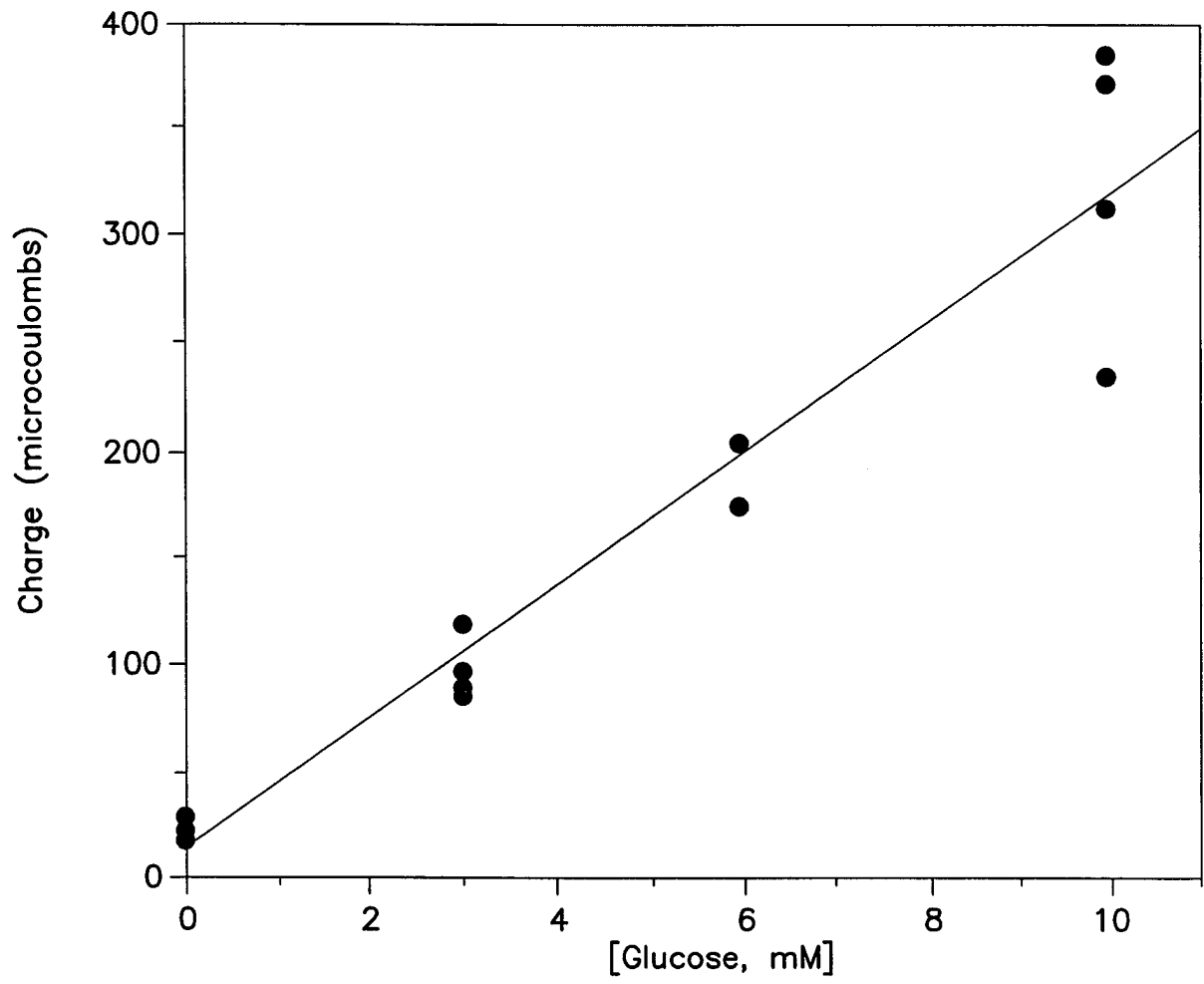

FIG. 10

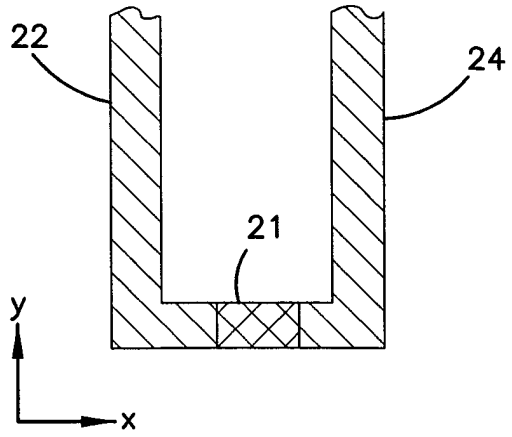

FIG. 11A

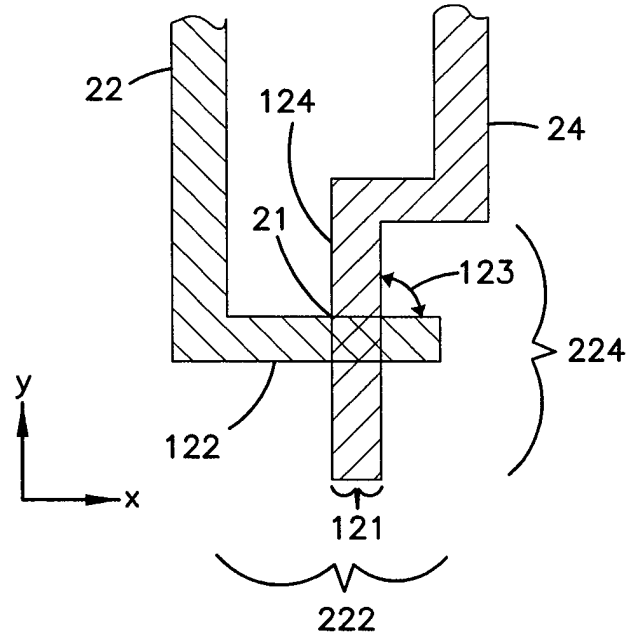

FIG. 11B

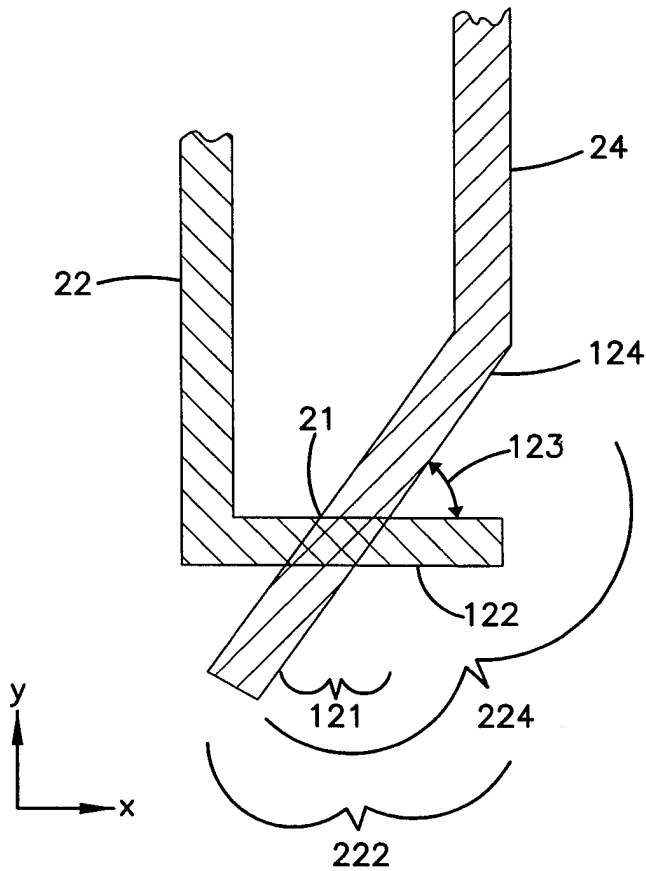

FIG. 11C

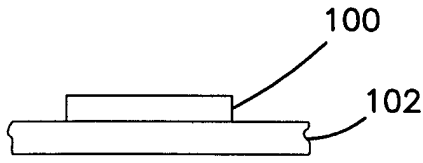

FIG. 12A

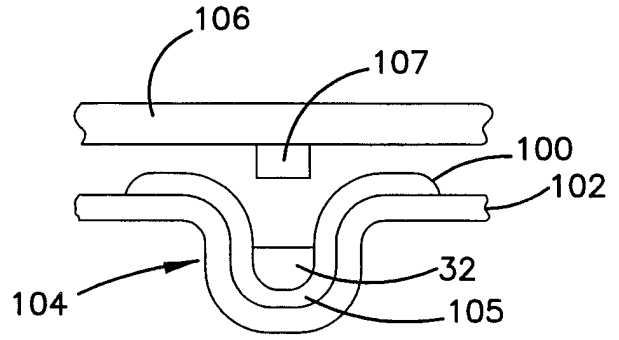

FIG. 12B

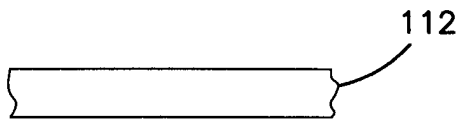

FIG. 13A

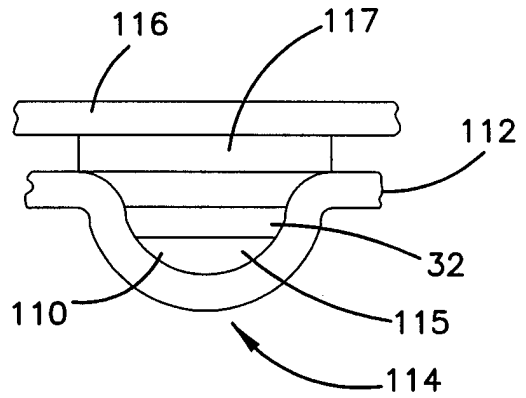

FIG. 13B

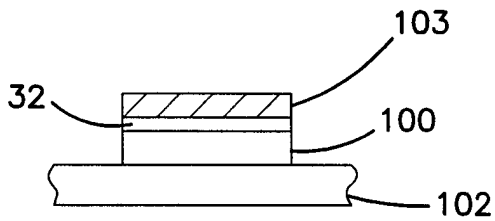

FIG. 14A

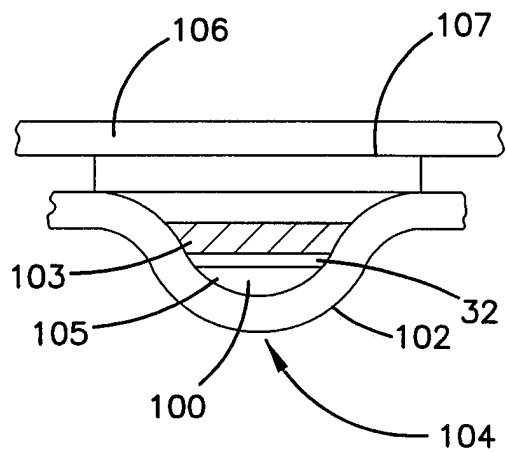

FIG. 14B

INTERNATIONAL SEARCH REPORT

International Application No

PCT/US 98/02652

A. CLASSIFICATION OF SUBJECT MATTER
 IPC 6 G01N27/327 C12Q1/00

According to International Patent Classification (IPC) or to both national classification and IPC

B. FIELDS SEARCHED

Minimum documentation searched (classification system followed by classification symbols)
 IPC 6 C12Q G01N

Documentation searched other than minimum documentation to the extent that such documents are included in the fields searched

Electronic data base consulted during the international search (name of data base and, where practical, search terms used)

C. DOCUMENTS CONSIDERED TO BE RELEVANT

Category	Citation of document, with indication, where appropriate, of the relevant passages	Relevant to claim No.
X	US 5 120 420 A (NANKAI SHIRO ET AL) 9 June 1992 see column 3, line 5 - column 4, line 4 --- -/--	1, 33, 51, 57, 66, 74, 77, 80, 82, 106, 116, 117, 123, 125, 127, 131, 132

Further documents are listed in the continuation of box C.

Patent family members are listed in annex.

Special categories of cited documents :

- "A" document defining the general state of the art which is not considered to be of particular relevance
- "E" earlier document but published on or after the international filing date
- "L" document which may throw doubts on priority claim(s) or which is cited to establish the publication date of another citation or other special reason (as specified)
- "O" document referring to an oral disclosure, use, exhibition or other means
- "P" document published prior to the international filing date but later than the priority date claimed

- "T" later document published after the international filing date or priority date and not in conflict with the application but cited to understand the principle or theory underlying the invention
- "X" document of particular relevance; the claimed invention cannot be considered novel or cannot be considered to involve an inventive step when the document is taken alone
- "Y" document of particular relevance; the claimed invention cannot be considered to involve an inventive step when the document is combined with one or more other such documents, such combination being obvious to a person skilled in the art.
- "&" document member of the same patent family

Date of the actual completion of the international search

Date of mailing of the international search report

22 June 1998

07/07/1998

Name and mailing address of the ISA
 European Patent Office, P.B. 5818 Patentlaan 2
 NL - 2280 HV Rijswijk
 Tel. (+31-70) 340-2040, Tx. 31 651 epo nl,
 Fax: (+31-70) 340-3016

Authorized officer
 Moreno, C

INTERNATIONAL SEARCH REPORT

International Application No

PCT/US 98/02652

C.(Continuation) DOCUMENTS CONSIDERED TO BE RELEVANT

Category	Citation of document, with indication, where appropriate, of the relevant passages	Relevant to claim No.
A	WO 95 02817 A (LION LAB PLC ;CRIDDLE WILLIAM JAMES (GB); HANSEN NEILS RICHARD STE) 26 January 1995 see the whole document ---	1,33,51, 57,66, 74,77, 80,82, 106,116, 117,123, 125,127, 131,132
A	EP 0 286 084 A (UNIV RAMOT) 12 October 1988 see the whole document ---	1,33,51, 57,66, 74,77, 80,82, 106,116, 117,123, 125,127, 131,132
A	WO 95 13534 A (WALLACE & TIERNAN LTD ;BONNICK DAVID MACDONALD (GB); DENNISON STEP) 18 May 1995 see the whole document ---	1,33,51, 57,66, 74,77, 80,82, 106,116, 117,123, 125,127, 131,132
A	US 5 130 009 A (MARSONER HERMANN ET AL) 14 July 1992 see the whole document ---	1,33,51, 57,66, 74,77, 80,82, 106,116, 117,123, 125,127, 131,132
A	C. W. ANDERSON ET AL: "A small volume thin-layer spectroelectrochemical cell for the study of biological components." ANALYTICAL BIOCHEMISTRY, vol. 93, no. 2, 1979, pages 366-372, XP002068329 see the whole document -----	

INTERNATIONAL SEARCH REPORT

Information on patent family members

International Application No

PCT/US 98/02652

Patent document cited in search report	Publication date	Patent family member(s)	Publication date
US 5120420 A	09-06-1992	JP 1253648 A	09-10-1989
		JP 2502665 B	29-05-1996
		JP 2062952 A	02-03-1990
		JP 2502666 B	29-05-1996
		JP 1291153 A	22-11-1989
		JP 1932654 C	26-05-1995
		JP 6058338 B	03-08-1994
		DE 68924026 D	05-10-1995
		DE 68924026 T	21-03-1996
		EP 0359831 A	28-03-1990
		WO 8909397 A	05-10-1989
WO 9502817 A	26-01-1995	AU 684090 B	04-12-1997
		AU 7128794 A	13-02-1995
		EP 0712492 A	22-05-1996
		US 5738773 A	14-04-1998
EP 0286084 A	12-10-1988	AT 108201 T	15-07-1994
		AU 621291 B	12-03-1992
		AU 1442088 A	13-10-1988
		CA 1312650 A	12-01-1993
		DE 3850515 D	11-08-1994
		DE 3850515 T	15-12-1994
		JP 1038646 A	08-02-1989
		US 5149629 A	22-09-1992
		ZA 8802369 A	23-09-1988
WO 9513534 A	18-05-1995	AU 8111994 A	29-05-1995
		EP 0728305 A	28-08-1996
		GB 2298047 A, B	21-08-1996
US 5130009 A	14-07-1992	AT 392847 B	25-06-1991
		EP 0385964 A	05-09-1990
		JP 2060778 C	10-06-1996
		JP 2232554 A	14-09-1990
		JP 7081984 B	06-09-1995