

(No Model.)

D. P. STANTON.
PIPE WRENCH.

No. 523,691.

Patented July 31, 1894.

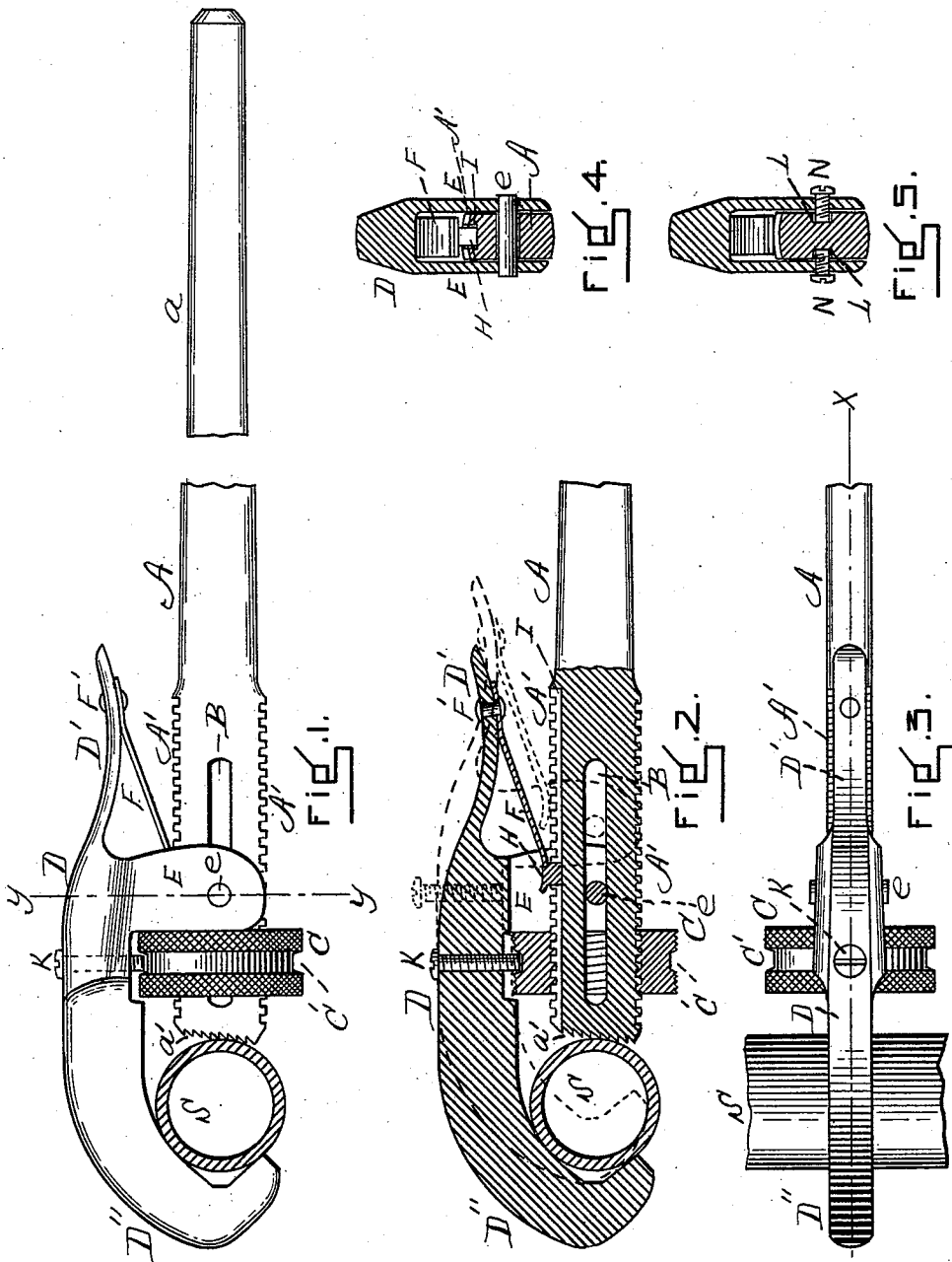

WITNESSES

E. A. Woodbury
B. M. Williams

INVENTOR

Daniel P. Stanton
By *his Atty*
Henry Williams

UNITED STATES PATENT OFFICE.

DANIEL P. STANTON, OF WARWICK, RHODE ISLAND.

PIPE-WRENCH.

SPECIFICATION forming part of Letters Patent No. 523,691, dated July 31, 1894.

Application filed June 1, 1894. Serial No. 513,173. (No model.)

To all whom it may concern:

Be it known that I, DANIEL P. STANTON, a citizen of the United States, residing at Warwick, in the county of Kent and State of Rhode Island, have invented a new and useful Improvement in Pipe-Wrenches, of which the following is a specification.

This invention has for its object to provide an improved construction for pipe-wrenches, whereby the wrench may be quickly and securely adjusted, made quick and sure in its operation, and be prevented from danger of crushing the pipe; and the nature of the invention consists in the novel construction and arrangement of parts fully described below, and illustrated in the accompanying drawings, in which—

Figure 1 represents a side elevation of my improved pipe-wrench. Fig. 2 is a longitudinal vertical section of the same, taken on line *x*, Fig. 3. Fig. 3 is a plan view. Fig. 4 is a cross section on line *y*, Fig. 1. Fig. 5 is a similar view showing a slight modification.

Similar letters of reference indicate corresponding parts.

A represents the stationary jaw provided with the usual handle *a*. This jaw is furnished with teeth *A'* on its upper and under side, and with inclined teeth *a'* on its end, and is moreover furnished with a longitudinal slot *B* as shown. The teeth *A'* are spiral, *i. e.*, cut so as to form portions of a screw, and on this jaw, by means of the screw-teeth *A'*, an internally screw-threaded ring or nut *C* moves, said ring being preferably serrated on its periphery.

D is the movable jaw provided with the handle or tail-piece *D'* and hook-shaped at its outer end *D''*, substantially as shown, although the exact shape illustrated of this hook may not be strictly adhered to. Integral ears *E* extend down from this jaw on both sides of the stationary jaw and a pivot or pin *e* extends from these ears through the slot *B*.

A spring *F* has its rear end secured at *F'* to the handle *D'* of the jaw *D*, while its free end has forged to it a block *H* which lies in a longitudinal groove *I* formed in the upper

side of the jaw *A* across the spiral teeth *A'*. The spring is at its free end preferably made broader than the said groove and may or may not rest on the teeth *A'*.

The ring or nut *C* is provided with an annular groove *C'* into which extends an adjustable screw *K* in the movable jaw *D*.

A piece of pipe is shown at *S*.

The movable jaw is opened by pressure on the end *D'* and may be readily moved longitudinally along the stationary jaw, the block *H* sliding in the groove *I* and being kept therein by the spring *F* and the pin *e* moving in the slot *B*. When the pipe has been grasped, the movable jaw is slid back and the ring *C* turned back on the screw-thread *A'* as shown in Fig. 1, and the grip on the pipe is secure.

The screw *K* may be used or not as desired. If it is used, it is screwed down into the annular groove *C'* in the ring *C* and serves as an adjustable step to prevent the pressure exerted on the pipe from being so great as to crush it, by taking some of said pressure on its end which lies in the groove.

In the modification shown in Fig. 5, grooves *L* on the sides of the jaw *A* take the place of the slot *B*, and screws are substituted for the pivot *e*.

Having thus fully described my invention, what I claim, and desire to secure by Letters Patent, is—

1. In a pipe-wrench, the combination of the stationary jaw *A* provided with the longitudinal slot *B* and screw-teeth *A'*, the ring or nut *C* on said screw-teeth, the movable jaw *D* provided with the ears *E* and sliding pivot *e* extending from said ears into said slot, and the spring *F* extending from the movable jaw and bearing on the upper side of the stationary jaw, substantially as set forth.

2. In a pipe-wrench, the combination of the stationary jaw *A* provided with the longitudinal slot *B*, screw-teeth *A'* and longitudinal groove *I* intersecting said screw-teeth, the ring or nut *C* on said screw-teeth, the movable jaw *D* provided with the sliding pivot *e* extending into said slot, and the spring *F* secured to the movable jaw and provided with the

block H sliding in said groove, substantially as described.

3. In a pipe-wrench, the combination of the stationary jaw A provided with the screw-teeth A', the movable jaw D secured to said
5 stationary jaw by a sliding pivot, the ring C moving on said screw-teeth and provided with

the annular groove C', and the screw K extending from said movable jaw into said groove, substantially as described.

DANIEL P. STANTON.

Witnesses:

EAGEN P. STANTON,
THOMAS J. TILLEY.