

(19)



(11)

EP 4 327 685 B1

(12)

EUROPEAN PATENT SPECIFICATION

(45) Date of publication and mention of the grant of the patent:

23.04.2025 Bulletin 2025/17

(21) Application number: **23189815.6**

(22) Date of filing: **04.08.2023**

(51) International Patent Classification (IPC):
A41D 13/018^(2006.01)

(52) Cooperative Patent Classification (CPC):
A41D 13/018

(54) **WEARABLE PROTECTION DEVICE**

TRAGBARES SCHUTZGERÄT

DISPOSITIF DE PROTECTION PORTABLE

(84) Designated Contracting States:

**AL AT BE BG CH CY CZ DE DK EE ES FI FR GB
GR HR HU IE IS IT LI LT LU LV MC ME MK MT NL
NO PL PT RO RS SE SI SK SM TR**

(30) Priority: **22.08.2022 IT 202200017448**

(43) Date of publication of application:
28.02.2024 Bulletin 2024/09

(73) Proprietor: **Dainese S.p.A.
36064 Colceresa (Vicenza) (IT)**

(72) Inventors:

- **AZZOLIN, Andrea
36064 Colceresa (Vicenza) (IT)**
- **ZORZIN, Giovanni
36064 Colceresa (Vicenza) (IT)**
- **Xausa, Simone
36064 Colceresa (Vicenza) (IT)**

(74) Representative: **Manfrin, Marta et al
Società Italiana Brevetti S.p.A.
Stradone San Fermo 21 sc. B
37121 Verona (VR) (IT)**

(56) References cited:

IT-A1- RM20 080 657 KR-A- 20120 102 434

EP 4 327 685 B1

Note: Within nine months of the publication of the mention of the grant of the European patent in the European Patent Bulletin, any person may give notice to the European Patent Office of opposition to that patent, in accordance with the Implementing Regulations. Notice of opposition shall not be deemed to have been filed until the opposition fee has been paid. (Art. 99(1) European Patent Convention).

Description

[0001] The present disclosure relates generally to the sector of providing protection by means of an airbag, so as to protect a user from impacts due to falling or sliding, when travelling on a means of transport, such as a vehicle, preferably a two-wheeled vehicle, or any other means of transport, such as a horse or other animal, sports equipment, such as a pair of skis or a bobsleigh, or similar means of transport. More particularly, the present disclosure relates to a wearable protection device including at least one inflatable element for protecting a user in the event of falls and/or impacts of various types.

[0002] In the sector relating to the protection of user it is in fact known to use a wearable protection device including an inflatable element which has a form such as to cover the torso of a user, both in a chest zone and in a back zone.

[0003] The inflatable element is inflated in the event of an impact by an inflation device which is placed in fluid communication with the said inflatable element. Generally, said inflation device includes a fluid source, such as a compressed gas cylinder, which is generally referred to as a gas generator. The gas generator is generally associated with a back portion of the wearable protection device or of a garment which incorporates said wearable protection device.

[0004] The arrangement of the gas generator on the back is facilitated by the fact that the back may be provided with a back protector which may support the gas generator. A plate-shaped support body which, when placed on the back, does not hinder the movements of the user may also be used instead of the back protector.

[0005] Basically, the wearable protection device includes a rigid protector or other support device for the back, which, in addition to the wearable protection function, performs a support function for the gas generator. In order to connect the gas generator to the inflatable element, a portion of the inflatable element connected to the gas generator is inserted inside the back protector or in the support device.

[0006] It has also been proposed inserting the gas generator in this portion of the inflatable element and including the combined assembly of the gas generator and the inflatable element in the back protector.

[0007] It should be pointed out that the position of the gas generator in the back area of a user makes the wearable protection device safer, preventing the gas generator from being able to interfere with the vital organs situated in the front part of the user, in the event of a fall.

[0008] The present disclosure is based on the recognition by the inventor of the present disclosure that a wearable protection device such as that made available by the prior art, while being advantageous from many points of view, has the drawback that it cannot be easily adapted in the case where the gas generator must be replaced after a first inflation of the inflatable element.

[0009] The document KR20120102434A discloses a

wearable protection device according to the preamble of claim 1.

[0010] In fact, if the gas generator is located inside the back protector, the latter must be disassembled in order to allow access to the gas generator. Disassembly for access to the gas generator may result in the risk of displacing also the inflatable element from its seat or, in any case, may require expert action on the wearable garment in order to change the gas generator and re-assemble the entire safety protection device.

[0011] It has therefore been proposed positioning the gas generator outside of the back protector on an external support which may be positioned on a surface of the back protector so that the gas generator is easily accessible without disassembly of the back protector. However, this solution results in an increase in the overall dimensions of the wearable protection device since a part of the wearable protection device is located outside the back protector.

[0012] Further solutions involve arranging the gas generator on one side of the back protector on the outside thereof, but this results in the wearable protection device being generally less comfortable.

[0013] The starting point of the present disclosure is the technical problem of providing a wearable protection device which is able to satisfy the aforementioned need with reference to the prior art for easy access to the gas generator, while maintaining compact dimensions of the entire wearable protection device and/or achieving further advantages and characteristic features.

[0014] This is obtained by means of a wearable protection device, a method for assembling an inflation device of the wearable protection device, and a garment according to the respective independent claims. Secondary characteristic features forming the subject of the present disclosure are defined in the corresponding dependent claims.

[0015] The wearable protection device, according to the present disclosure, comprises at least one inflatable element, a gas generator and a coupling device for coupling the gas generator to the inflatable element, the coupling device including a coupling element associated with the gas generator and a coupling counter-element associated with the inflatable element.

[0016] The expression "support device" is generally understood as meaning a body or assembly, which may be plate-shaped and/or closed in the manner of a box/casing able to support the components of the device and in particular the gas generator. The support device may be particularly suitable for arrangement on the back of a user and/or also have the configuration of a back protector.

[0017] According to one aspect of the present disclosure, the inflatable element includes a primary portion of the inflatable element and a secondary portion of the inflatable element. The secondary portion of the inflatable element is connected as one piece with the primary portion and is provided with said coupling counter-ele-

ment, wherein the support device is at least partially superimposed on the primary portion of the inflatable element so as to form a multilayer structure therewith, and said secondary portion protrudes with respect to said support device and is in the folded or overturned condition, or a folding or overturning condition, said folding or overturning condition corresponding to a housing condition of said coupling counter-element in said receiving seat of the support device.

[0018] Preferably, the folded or overturned condition is understood as being a condition in which the secondary portion is folded or overturned onto itself, namely protrudes from the primary portion and is folded back from the primary portion.

[0019] In this condition, the inflatable element may be connected with the gas generator and allows inflation of the inflatable element.

[0020] This solution offers numerous advantages. The first advantage consists in the fact that a primary portion consisting of the inflatable element with a protective function may be placed underneath the wearable protection device, on the user side, and is configured so that the coupling counter-element protrudes with respect to the support device, by means of the secondary portion. The secondary portion, being in the folded or overturned condition, may allow the coupling counter-element to be inserted inside the receiving seat with significant control of the overall dimensions. In this way, the support device may be superimposed on the inflatable element and allow the wearable protection device to offer double protection both on the side of the support device and on the side of the inflatable element and at the same time provide a minimal small-size connection between the gas generator and the inflatable element.

[0021] Preferably, the overturning or folding condition is a condition in which the secondary portion is folded 180° about itself and/or with respect to the primary portion, namely it consists of a full fold which results in an overlapping arrangement of two secondary portion parts and/or at least one part of the secondary portion with respect to the primary portion.

[0022] In this condition the secondary portion may be arranged substantially squashed and flat without substantially additional volume in the deflated condition.

[0023] Preferably, the support device has a through-opening configured to allow access to said receiving seat and is designed to receive a secondary portion part of the inflatable element which carries the coupling counter-element or also only the coupling counter-element so as to allow stable coupling between the inflatable element and the gas generator arranged inside the receiving seat.

[0024] Preferably, the wearable protection device has a user-side area, namely an area or portion intended to face the body of a user. In other words, when the wearable protection device is worn, it defines an area for receiving the user's body. In this condition, when the wearable protection device is worn by said user, the primary portion of the inflatable element is arranged

underneath the support device, namely on the side of said user-side area with respect to the support device. Consequently, as a result of the aforementioned layout of the aforementioned parts, the secondary portion protrudes from the support device and is folded outwards, preferably through 180°, towards the support device so as to reach the receiving seat.

[0025] Preferably, said through-opening is arranged on the side of said user-side area and is therefore preferably hidden from view. In this condition, the secondary portion of the inflatable element is folded so as to be arranged between the support device and the primary portion of the support element and is therefore only marginally visible. In other words, the connection between the inflatable element and the gas generator may therefore be not only compact in size, but also hidden from view.

[0026] Preferably, the secondary portion of the inflatable element is a peripheral appendage which does not have a wearable protection function but only serves to provide the connection between the primary portion and the gas generator receiving seat.

[0027] Even more preferably, the wearable protection device is configured and organized so that the coupling counter-element is permanently received inside the receiving seat and the gas generator is connected if necessary by means of the respective coupling element to the coupling counter-element. The connection may be of the removable type, so that, once inflation of the inflatable element is performed, it is necessary merely to remove and replace the gas generator. The receiving seat may be configured to include elastic coupling elements, for example of the clip type, so as to allow a stable form-fit and at the same time rapid removal of the gas generator in/from the coupling seat.

[0028] Preferably, the support device comprises a bottom or base structure which includes said seat for receiving the gas generator, and a wearable protective cover for the gas generator, said wearable protective cover being removable from said bottom or base structure.

[0029] It is to be understood that the support device may be made of a soft material or a material which is not necessarily rigid.

[0030] Preferably, the bottom or base structure is arranged on the user side and the wearable protection cover faces the opposite side, namely an outer side. In this way, a user may access the gas generator from the outside. The support device is configured to support also further functional elements for the wearable protection device, such as a control unit and sensors for detecting a danger situation.

[0031] As mentioned above, the wearable protection device may also have a back protector or generally wearable protection function for the back. More generally, preferably, the primary portion of the inflatable element is a portion providing wearable protection for the back of a user, and the support device is superimposed on said primary portion on the back so as to have mini-

mum dimensions and a minimum impact for a user. The inflatable element therefore extends over the back as far as a neck zone. The secondary portion is a peripheral portion with respect to the primary portion and preferably is a portion which projects in the manner of an appendage or an extension extending in a neck zone of the inflatable element, and is in a condition folded or bent back towards the back.

[0032] The position of the support device on the back allows or does not hinder flexing and twisting movements of the user's back.

[0033] Preferably, the inflatable element overall is a structure which protects the main portions of a user's torso and comprises inflatable element portions on the back and chest, leaving free a central cavity where the user's head is inserted. In these conditions, the inflatable element is cut to size to define said cavity and therefore there are normally inflatable element waste portions which are not used. The secondary portion is formed preferably precisely in said regions which would be waste regions, safeguarding therefore inflatable element portions which otherwise would be eliminated and without therefore using additional portions of the inflatable element.

[0034] Further advantages, characteristic features and modes of use forming the subject of the present disclosure will become clear from the following detailed description of a number of preferred examples of embodiment thereof, provided by way of a nonlimiting example.

[0035] It is nevertheless evident that each embodiment may have one or more of the advantages listed above; in any case it is nevertheless not necessary that each embodiment should have simultaneously all the advantages listed.

[0036] Reference will be made to the figures of the attached drawings in which:

- Figure 1 shows a view, from the rear, of a wearable protection device according to an embodiment of the present disclosure;
- Figure 2 shows another view of a wearable protection device according to an embodiment of the present disclosure, in a condition resting on a surface;
- Figures 3 and 4 show corresponding views of the wearable protection device of Figures 1 and 2 during the assembly steps;
- Figure 5 shows a cross-sectional view of the wearable protection device according to Figure 2;
- Figure 4 shows a view of a garment which includes a personal protection device according to Figures 1 and 2.

[0037] With reference to the attached figures, the reference number 10 indicates a wearable protection device according to the present disclosure.

[0038] "Wearable protection device" is understood as meaning a device which may be worn, namely placed on a user's body with a protective function, or which can be

associated with or is designed to be associated with a garment or an undergarment, such as a motorcycling suit, a jacket, a vest or a pair of trousers. Since it is a device which can be preferably worn, in the context of the present disclosure reference will be made for greater clarity to parts of the body which said wearable protection device is intended to protect, and in general to spatial references such as above, below, inner and outer and similar references which are to be understood in a non-limiting manner as though the device were being worn.

[0039] The wearable protection device 10 according to the present disclosure comprises at least one inflatable element 12, a gas generator 14 and a coupling device 16 for coupling the gas generator 14 to the inflatable element 12 (Figure 5).

[0040] The coupling device 16 includes a coupling element 18 associated with the gas generator 14 and a coupling counter-element 20 associated with the inflatable element 12. It should be noted that in Figure 4 the coupling counter-element 20 is detached from the inflatable element since it consists of an assembly stage. However, once the entire wearable protection device 10 is assembled, the coupling counter-element 20 is associated preferably permanently with the inflatable element 12. The coupling counter-element 20 may be preferably a bush-like body associated with the inflatable element 12.

[0041] The gas generator 14 may be a structure which is for example canister-shaped, namely has a substantially cylindrical structure. The gas generator 14 is to be understood as being a source of inflation fluid and may be a gas generator of the pyrotechnic or hybrid type or other types known according to the state of the art.

[0042] The wearable protection device 10 further comprises a support device 30 defining a receiving seat 32 for receiving the gas generator 14 and the coupling device 16 and allowing coupling together of the inflatable element 12 and the gas generator 14 inside said receiving seat 32.

[0043] According to one aspect of the present disclosure, the inflatable element 12 includes a primary portion 22 of the inflatable element 12 and a secondary portion 24 of the inflatable element 12 connected as one piece with the primary portion 22.

[0044] The secondary portion 24 is provided with, or supports, said coupling counter-element 20.

[0045] The support device 30 is at least partially superimposed on the primary portion 22 of the inflatable element 12 so as to form a multilayer structure. The secondary portion 24 protrudes with respect to said support portion 30.

[0046] Furthermore, advantageously, the secondary portion 24 of the inflatable element 12 is in the folded or overturned condition, or folding or overturning condition, towards the support device 30. The folding or overturning condition corresponds to a housing condition of the coupling counter-element 20 in said receiving seat 32. In particular, in said folding or overturning condition,

the coupling counter-element 20 is in said receiving seat 32 of the support device 30 and already connected to the secondary portion 24 of the inflatable element 12.

[0047] In this condition, the inflatable element 12 may be connected with the gas generator 14 and allows inflation of the inflatable element 12. In other words the secondary portion 24 supports the coupling counter-element 20 and may be folded towards the support device 30 to allow housing of the coupling counter-element 20 inside the receiving seat 32 with consequent significant control of the overall dimensions. The secondary portion 24 may also be partly housed inside the receiving seat 32 or may be arranged outside such that the only the coupling counter-element 20 is inside the receiving seat 32. In fact, said part of the secondary portion is arranged so as to project or only face into the receiving seat 32 so that the coupling counter-element 20 may be then fixed inside the receiving seat 32.

[0048] In this way the support device 30 may be superimposed on the primary portion 22 of the inflatable element 12 and double protection provided both by the support device and by the inflatable element 12 while ensuring a minimum small-size connection with the inflatable element 12.

[0049] The secondary portion 24 of the inflatable element may not have any protective function and act only as a connecting element between the primary portion and the gas generator 14. It is pointed out that the inflatable element 12 may be cut to size so that the secondary portion 24 may be, or correspond to, a cut-out or waste portion of the inflatable element 12, for example, as explained below, in the neck region.

[0050] Furthermore, preferably, the overturning or folding condition is a condition in which the secondary portion 24 is folded 180° about itself and/or with respect to the primary portion, namely it consists of a full fold which results in the overlapping arrangement of a secondary portion 24 with respect to the primary portion 22. In other words, the secondary portion 24 is a portion without a protective function which acts only as a connection and may be obtained from a perimetral zone of the inflatable element (which otherwise would be cut off) and folded backwards 180° preferably above, or below, the primary portion, so as to reach the receiving seat.

[0051] In this condition the secondary portion 24 may be arranged substantially squashed and flat onto the primary portion 22 without substantially additional volume in the deflated condition.

[0052] In the embodiment shown, the inflatable element 12 is intended to protect at least partially a torso area of the user. More precisely, in the embodiment shown, the inflatable element 12 includes a first part 121 intended to be placed in the neck region, chest parts 122, 123 each intended to be placed along a right-hand and a left-hand region of the chest, respectively, and a spinal or back portion 126 intended to be placed along a back region which is centred on the backbone of the user. The aforementioned primary portion 22 of the inflatable

element 12 may be understood as being part of the spinal portion 126 of the embodiment shown, underlying the support device 30.

[0053] The parts 121 122 123, 126 of the inflatable element 12 are pneumatically connected together to form a single inflatable chamber. Preferably, in the embodiment shown in the drawings, the support device covers an outer side, namely a side opposite to the user, part of the spinal portion 126 and, together with the spinal portion 126 of the inflatable element 12, is intended to protect the backbone of the user. It may be understood how the support device 30 may also have other forms, and the form shown is not to be regarded as limiting for the purposes of the present disclosure.

[0054] As a result, preferably, as regards the layout of the parts described above, the wearable protection device 10 has a user-side area 38, namely an area or portion intended to face the user's body when the wearable protection device 10 is worn by said user, and the inflatable element portion is arranged on said user-side area 38 with respect to the support device 30. The secondary portion 24 protrudes from the support device 30 and is in a condition folded backwards or on the outside, preferably through 180°, towards the support device 30 so as to create said connection with the receiving seat 32.

[0055] Preferably, from a constructional point of view, the support device has a through-opening 40, which is preferably arranged in said user-side area 38, and wherein said through-opening 40 is an opening configured to allow access to said receiving seat 32 and is designed to receive the coupling counter-element 20 associated with the inflatable element 12 so as to ensure a stable connection between the inflatable element 12 and the gas generator 14 arranged in said receiving seat 32. In other words, when the wearable protection device 10 is worn, it defines an area for receiving the user's body. In this condition, the support device 30 has a side 38 facing the user's body, and this through-opening 40 is arranged on this side 38 facing the user's body so that the secondary portion 24 of the inflatable element 12 may be inserted between the support device 30 and the primary portion 12 on side which is hidden from view.

[0056] Preferably, as mentioned, the secondary portion 24 of the inflatable element is a peripheral appendage which does not have a protective function but only serves to provide the connection between the primary portion 22 and the receiving seat 32 for housing the gas generator 24.

[0057] Even more preferably, in the embodiment shown, the secondary portion 24 is an appendage which extends into the cavity which is intended to receive the user's neck and is in a condition folded backwards, namely outwards, so as to be inserted underneath the support device 30 and reach the through-slot 40. This zone is usually a waste zone and therefore the appendage is a part of the inflatable element which does not require additional production costs, since it merely in-

volves a cut with a different design.

[0058] It may be stated that, once it faces the end part of the secondary portion 24 inside the through-slot 40, the coupling counter-element 20 may be permanently fixed to the end of the secondary portion 24 and therefore the coupling counter-element 20 may remain permanently seated inside the receiving seat 12, and the gas generator 14 connected by means of the respective coupling element 18 to the coupling counter-element 20. The connection may be of a mechanical connection of the removable type, so that, once inflation of the inflatable element 12 is performed, it is required to remove and replace only the gas generator 14. The receiving seat 32 preferably includes elastic coupling elements, for example of the clip type, so as to allow a stable form-fit and also rapid removal of the gas generator 14 in/from the coupling seat 32. The coupling device 16 may be of any type according to the prior art.

[0059] Preferably, the support device 30 comprises a bottom or base structure 50 which includes said receiving seat 32 for the gas generator 14, and a protective cover 52 for protecting the gas generator 14. The protective cover 52 is removably associated with said bottom or base structure by means of a mechanical connection of the known type.

[0060] Preferably, from a constructional point of view, the bottom or base structure 50 is arranged on the user side 38 and the protective cover 52 faces the opposite side, namely an outer side. The support device 30 is configured to support also further functional elements for the wearable protection device, such as a control unit and sensors for detecting a danger situation. These further elements are generally indicated by the reference number 53 in the figures.

[0061] It may be pointed out that, owing to the present disclosure, the primary portion of the inflatable element may perform its function and be connected to the gas generator while occupying a minimum volume, owing to the secondary portion which protrudes from the volume of the support device and which, once folded back towards the support device 30, defines a kind of double layer because of the fold. This double layer of the secondary portion advantageously and preferably has an overall thickness which is much less than the thickness of the support device 30.

[0062] With regard to the inflatable element 12, it is pointed out that it may be a single bag and made using the technology described in the patent application PCT/IB2009/055512 and in the patent application PCT/IT2009/000547. This inflatable element 12 has a small thickness also in the inflated condition and therefore the aforementioned double layer does not occupy extra space even in the inflated condition.

[0063] The wearable protection device 10 according to the present disclosure may be worn on its own as a separate garment, optionally lined with a fabric aesthetically pleasing for the user, or made of a comfortable and practical fabric, or may be incorporated in suitable pock-

ets inside a garment, such as a motorcyclist's suit or jacket.

[0064] With reference to Figure 6, the present disclosure in fact also relates to a protective garment 100 comprising a wearable protection device 10 such as that described above and including an inflatable element 12 and the support device 30. In this embodiment, the parts which perform the same function have the same reference number.

[0065] In particular, the support device 30 may be arranged on top of an outer layer 101 and the inflatable element 12 may be arranged below the outer layer 101 of the garment, so that it is hidden from view. The respective secondary portion 24 may be inserted inside a seat passing through the outer layer 101 and arranged below the support device 30 so as to reach the seat 32.

[0066] It is however possible for the inflatable element 12 to be shaped directly as a garment and for the inflatable element to be provided with laces, hooks, ribbons or other means known to the person skilled in the art, in order to ensure suitable wearability. In other words, it is to be understood that the wearable protection device 10 according to the present disclosure may be worn on its own as a separate garment, optionally lined with a fabric aesthetically pleasing for the user, or made of a comfortable and practical fabric, or may be incorporated in suitable pockets inside a garment, such as a motorcyclist's suit or jacket.

[0067] Even if the wearable protection device 10 were shaped as a garment, the secondary portion 24 may have a minimum visual impact for the user from the outside or may be covered by a cover.

[0068] Alternatively again, owing to the minimum dimensions, the wearable protection device 10 may be included inside a lining of a garment in a removable manner. In particular a user may fix and connect, as required, an inflatable element 12 to the respective garment 100 and then wear the garment 100 already equipped with said wearable protection device 10. As a result, a user may use the same wearable protection device 10 with different garments 100 and change the wearable protection device 10 depending on the garment 100 chosen and the activity to be performed.

[0069] With regard to inflation, in order to perform inflation of the inflatable element 12, in the event of a fall and/or sliding and/or sudden impact involving a user or a vehicle being ridden/driven, the wearable protection device 10 is adapted to cooperate with special activation means (not shown) which are operationally connected to the pressurised gas generator 14 and associated with the components 53 indicated above. Opening of the shut-off valve of the gas generator 14 is preferably controlled by the control and management unit depending on detection of the user state; for example said control unit (which forms part of said activation means 53) may implement a system for predicting the fall which allows early identification of the fall event and a reliable prediction of this by accelerometer sensor means fixed to the vehicle/ski (or

rider/skier) and a unit for processing the signals produced by the said sensors.

[0070] Alternatively, the device according to the present disclosure may also be applied using an activation cable connected to a vehicle ridden/driven by a user, which cable activates inflation of the inflatable element following the movement of the user away from the vehicle, for example following a fall or a sudden impact.

[0071] In any case the aforementioned activation and inflation means 53 may be integrated in the wearable protection device according to the present invention or located on the outside thereof.

[0072] It should also be noted that the activation modes, although being an aspect of particular importance for effective operation of the device, will not be further described in greater detail since they are methods which are essentially already known to a person skilled in the art of protection of a person from sudden impacts. The subject of the present disclosure has been described hitherto with reference to preferred embodiments.

Claims

1. Wearable protection device (10) comprising at least one inflatable element (12), a gas generator (14) and a coupling device (16) for coupling the gas generator (14) to the inflatable element (12), wherein the coupling device (16) includes a coupling element (18) associated with the gas generator (14) and a coupling counter-element (20) associated with the inflatable member (12), wherein the wearable protection device (10) comprises a support device (30) defining a receiving seat (32) for receiving the gas generator (14) with respective coupling element (18), and the inflatable element (12) includes at least one primary portion (22) of the inflatable element (12) and a secondary portion (24) of the inflatable element (12) connected as one piece with the primary portion (22), the secondary portion (24) of the inflatable element (12) being provided with said coupling counter-element (20), the wearable protection device being **characterized in that**, the support device (30) is at least partially superimposed on the primary portion (22) of the inflatable element (12) to form a multilayer structure and the secondary portion (24) protrudes with respect to said support device (30), said secondary portion (24) of the inflatable element (12) being in a folded or overturned condition, or a folding or overturning condition, towards the support device (30), the folding or overturning condition corresponding to a housing condition of said coupling counter-element (20) in said receiving seat (32).
2. Wearable protection device (10) according to claim 1, wherein the secondary portion (24) of the inflatable element (12) acts as a connection between the

primary portion (22) of the inflatable element (12) and the gas generator (14) .

3. Wearable protection device (10) according to claim 1 or 2, wherein the secondary portion (24) of the inflatable element (12) is an edge portion of the primary portion (22) of the inflatable element (12).
4. Wearable protection device (10) according to claim 1 or 2, wherein the secondary portion (24) of the inflatable element (12) defines a single chamber with said primary portion (22) of the inflatable element (12).
5. Wearable protection device (10) according to any one of the preceding claims, wherein the secondary portion (24) of the inflatable element (12) is, or corresponds to, a cut-out or a waste portion of the inflatable element (12).
6. Wearable protection device (10) according to any one of the preceding claims, wherein the overturning or folding condition is a condition in which the secondary portion is folded or overturned onto itself, namely protrudes from the primary portion and is folded back from the primary portion.
7. Wearable protection device (10) according to any one of the preceding claims, wherein the overturned or folded condition is a condition in which a part of the secondary portion (24) of the inflatable element (12) is folded 180° with respect to another part of the secondary portion (24) of the inflatable element (12), and/or wherein the secondary portion (24) of the inflatable element (12) is folded 180° with respect to the primary portion (22) of the inflatable element (12).
8. Wearable protection device (10) according to any one of the preceding claims, wherein the inflatable element (12) includes a neck part (121) intended to be placed opposite the neck region of a user, and said secondary portion (24) of the inflatable element (12) is an appendage protruding from said neck part (121).
9. Wearable protection device (10) according to the preceding claim, wherein the inflatable element (12) has a spinal or back portion (126) intended to be placed along a back region, and wherein said primary portion (22) of the inflatable element (12) is a part of the spinal portion (126) underlying the support device (30).
10. Wearable protection device (10) according to any one of the preceding claims, wherein the wearable protection device (10) defines a user-side area (38), and said primary portion (22) of the inflatable ele-

ment (12) is arranged on the side of said user-side area (38) with respect to the support device (30) and a part of said secondary portion in the folded or overturned condition is inserted between said support device (30) and the primary portion (22).

11. Wearable protection device (10) according to the preceding claim, wherein said secondary portion (24) of the inflatable element (12) protrudes with respect to the support device (30) towards a neck area.

12. Wearable protection device (10) according to any one of the preceding claims, wherein the support device (30) has a through-opening (40) configured to allow access to said receiving seat (32) and is adapted to receive a part of the secondary portion (24) carrying the coupling counter-element (20) or only the coupling counter-element (20).

13. Wearable protection device (10) according to claims 10 and 12, or 11 and 12, wherein the through-opening (40) is arranged in said user-side area (38), and the secondary portion (24) of the inflatable element (12) is partially arranged between the support device (30) and the primary portion (22) of the inflatable element (12).

14. Wearable protection device (10) according to claims 10 and 12, or 11 and 12, or according to claim 13, wherein the receiving seat (32) is accessible for a user from the outer side opposite the user-side area (38).

15. Wearable protection device (10) according to any one of the preceding claims, wherein the support device (30) is configured to further support a control unit for controlling inflation of the inflatable element (12).

16. Wearable article (100), such as a garment, comprising a wearable protection device (10) according to any one of the preceding claims.

17. Assembly method for assembling a wearable protection device (10) according to any one of claims 1-15 comprising at least one inflatable element (12) and a gas generator (14); the method comprising the steps of:

- equipping the gas generator (14) with a coupling element (18);
- placing the gas generator (14) in a receiving seat (32) of a support device (30) and placing the support device (30) on a primary portion (22) of the inflatable element (12), so that a secondary portion (24) of the inflatable element (12) protrudes from the support device (30);

- folding the secondary portion (24) of the inflatable element (12) towards the support device (30) so that at least a part of said secondary portion (24) of the inflatable element (12) protrudes or faces into the receiving seat (32) and providing said part of said secondary portion (24) of the inflatable element (12) with a coupling counter-element (20);

- coupling the coupling counter-element (20) with the coupling element (18) associated with the gas generator (14).

18. Assembly method according to claim 17, wherein the part of said secondary portion (24) of the inflatable element (12) is folded and passed between support device (30) and primary portion (22) of the inflatable element (12) so as to reach said receiving seat (32).

19. Assembly method according to claim 17 or 18, wherein, after inflation of the inflatable element (12), the gas generator (14) is replaced by keeping the part of said secondary portion (24) of the inflatable element (12) fixed inside the receiving seat (32) with said coupling counter-element (20).

Patentansprüche

1. Am Körper tragbare Schutzvorrichtung (10), umfassend mindestens ein aufblasbares Element (12), einen Gasgenerator (14) und eine Kopplungsvorrichtung (16) zum Koppeln des Gasgenerators (14) mit dem aufblasbaren Element (12), wobei die Kopplungsvorrichtung (16) ein Kopplungselement (18), das dem Gasgenerator (14) zugeordnet ist, und ein Kopplungsgegenelement (20), das dem aufblasbaren Element (12) zugeordnet ist, einschließt, wobei die am Körper tragbare Schutzvorrichtung (10) eine Stützevorrichtung (30) umfasst, die einen Aufnahmesitz (32) zum Aufnehmen des Gasgenerators (14) mit einem jeweiligen Kopplungselement (18) definiert, und das aufblasbare Element (12) mindestens einen primären Abschnitt (22) des aufblasbaren Elements (12) und einen sekundären Abschnitt (24) des aufblasbaren Elements (12) einschließt, der einstückig mit dem primären Abschnitt (22) verbunden ist, wobei der sekundäre Abschnitt (24) des aufblasbaren Elements (12) mit dem Kopplungsgegenelement (20) versehen ist, wobei die am Körper tragbare Schutzvorrichtung **dadurch gekennzeichnet ist, dass** die Stützevorrichtung (30) mindestens teilweise dem primären Abschnitt (22) des aufblasbaren Elements (12) überlagert ist, um eine mehrschichtige Struktur zu bilden, und der sekundäre Abschnitt (24) in Bezug auf die Stützevorrichtung (30) hervorragt, wobei sich der sekundäre Abschnitt (24) des aufblasbaren Elements (12) in einem gefalteten oder umgeschlagenen Zustand

- oder einem falt- oder Umschlagzustand in Richtung der Stützvorrichtung (30) befindet, wobei der falt- oder Umschlagzustand einem Unterbringungszustand des Kopplungsgegenelements (20) in dem Aufnahmesitz (32) entspricht.
2. Am Körper tragbare Schutzvorrichtung (10) nach Anspruch 1, wobei der sekundäre Abschnitt (24) des aufblasbaren Elements (12) als eine Verbindung zwischen dem primären Abschnitt (22) des aufblasbaren Elements (12) und dem Gasgenerator (14) fungiert.
 3. Am Körper tragbare Schutzvorrichtung (10) nach Anspruch 1 oder 2, wobei der sekundäre Abschnitt (24) des aufblasbaren Elements (12) ein Randabschnitt des primären Abschnitts (22) des aufblasbaren Elements (12) ist.
 4. Am Körper tragbare Schutzvorrichtung (10) nach Anspruch 1 oder 2, wobei der sekundäre Abschnitt (24) des aufblasbaren Elements (12) mit dem primären Abschnitt (22) des aufblasbaren Elements (12) eine einzelne Kammer definiert.
 5. Am Körper tragbare Schutzvorrichtung (10) nach einem der vorstehenden Ansprüche, wobei der sekundäre Abschnitt (24) des aufblasbaren Elements (12) ein Ausschnitt oder ein Abfallabschnitt des aufblasbaren Elements (12) ist oder einem solchen entspricht.
 6. Am Körper tragbare Schutzvorrichtung (10) nach einem der vorstehenden Ansprüche, wobei der Umschlag- oder faltzustand ein Zustand ist, in dem der sekundäre Abschnitt auf sich selbst gefaltet oder umgeschlagen ist, nämlich aus dem primären Abschnitt hervorragt und von dem primären Abschnitt zurückgefaltet ist.
 7. Am Körper tragbare Schutzvorrichtung (10) nach einem der vorstehenden Ansprüche, wobei der umgeschlagene oder gefaltete Zustand ein Zustand ist, in dem ein Teil des sekundären Abschnitts (24) des aufblasbaren Elements (12) in Bezug auf einen anderen Teil des sekundären Abschnitts (24) des aufblasbaren Elements (12) um 180° gefaltet ist, und/oder wobei der sekundäre Abschnitt (24) des aufblasbaren Elements (12) in Bezug auf den primären Abschnitt (22) des aufblasbaren Elements (12) um 180° gefaltet ist.
 8. Am Körper tragbare Schutzvorrichtung (10) nach einem der vorstehenden Ansprüche, wobei das aufblasbare Element (12) einen Halsteil (121) einschließt, der dazu vorgesehen ist, gegenüber dem Halsbereich eines Benutzers platziert zu werden, und der sekundäre Abschnitt (24) des aufblasbaren Elements (12) ein Anhängsel ist, das von dem Halsteil (121) hervorragt.
 9. Am Körper tragbare Schutzvorrichtung (10) nach dem vorstehenden Anspruch, wobei das aufblasbare Element (12) einen Wirbelsäulen- oder Rückenabschnitt (126) aufweist, der dazu vorgesehen ist, entlang eines Rückenbereichs platziert zu werden, und wobei der primäre Abschnitt (22) des aufblasbaren Elements (12) ein Teil des Wirbelsäulenabschnitts (126) ist, der unter der Stützvorrichtung (30) liegt.
 10. Am Körper tragbare Schutzvorrichtung (10) nach einem der vorstehenden Ansprüche, wobei die am Körper tragbare Schutzvorrichtung (10) einen benutzerseitigen Bereich (38) definiert und der primäre Abschnitt (22) des aufblasbaren Elements (12) in Bezug auf die Stützvorrichtung (30) auf der Seite des benutzerseitigen Bereichs (38) angeordnet ist und ein Teil des sekundären Abschnitts im gefalteten oder umgeschlagenen Zustand zwischen der Stützvorrichtung (30) und dem primären Abschnitt (22) eingefügt ist.
 11. Am Körper tragbare Schutzvorrichtung (10) nach dem vorstehenden Anspruch, wobei der sekundäre Abschnitt (24) des aufblasbaren Elements (12) in Bezug auf die Stützvorrichtung (30) in Richtung eines Halsbereichs hervorragt.
 12. Am Körper tragbare Schutzvorrichtung (10) nach einem der vorstehenden Ansprüche, wobei die Stützvorrichtung (30) eine Durchgangsöffnung (40) aufweist, die konfiguriert ist, um Zugang zu dem Aufnahmesitz (32) zu ermöglichen, und dazu geeignet ist, einen Teil des sekundären Abschnitts (24), der das Kopplungsgegenelement (20) trägt, oder nur das Kopplungsgegenelement (20) aufzunehmen.
 13. Am Körper tragbare Schutzvorrichtung (10) nach den Ansprüchen 10 und 12 oder 11 und 12, wobei die Durchgangsöffnung (40) in dem benutzerseitigen Bereich (38) angeordnet ist und der sekundäre Abschnitt (24) des aufblasbaren Elements (12) teilweise zwischen der Stützvorrichtung (30) und dem primären Abschnitt (22) des aufblasbaren Elements (12) angeordnet ist.
 14. Am Körper tragbare Schutzvorrichtung (10) nach den Ansprüchen 10 und 12 oder 11 und 12 oder nach Anspruch 13, wobei der Aufnahmesitz (32) für einen Benutzer von der dem benutzerseitigen Bereich (38) gegenüberliegenden Außenseite her zugänglich ist.
 15. Am Körper tragbare Schutzvorrichtung (10) nach

einem der vorstehenden Ansprüche, wobei die Stützvorrichtung (30) konfiguriert ist, um ferner eine Steuereinheit zum Steuern des Aufblasens des aufblasbaren Elements (12) zu unterstützen.

16. Am Körper tragbarer Artikel (100), wie ein Kleidungsstück, umfassend eine am Körper tragbare Schutzvorrichtung (10) nach einem der vorstehenden Ansprüche.

17. Montageverfahren zum Montieren einer am Körper tragbaren Schutzvorrichtung (10) nach einem der Ansprüche 1 bis 15, umfassend mindestens ein aufblasbares Element (12) und einen Gasgenerator (14); wobei das Verfahren die Schritte umfasst:

- Ausstatten des Gasgenerators (14) mit einem Kopplungselement (18);

- Platzieren des Gasgenerators (14) in einem Aufnahmesitz (32) einer Stützvorrichtung (30) und Platzieren der Stützvorrichtung (30) an einem primären Abschnitt (22) des aufblasbaren Elements (12), sodass ein sekundärer Abschnitt (24) des aufblasbaren Elements (12) aus der Stützvorrichtung (30) herausragt;

- Falten des sekundären Abschnitts (24) des aufblasbaren Elements (12) in Richtung der Stützvorrichtung (30), sodass mindestens ein Teil des sekundären Abschnitts (24) des aufblasbaren Elements (12) in den Aufnahmesitz (32) hineinragt oder in diesen zeigt, und Versehen des Teils des sekundären Abschnitts (24) des aufblasbaren Elements (12) mit eines Kopplungsgegenelement (20);

- Koppeln des Kopplungsgegenelements (20) mit dem Kopplungselement (18), das dem Gasgenerator (14) zugeordnet ist.

18. Montageverfahren nach Anspruch 17, wobei der Teil des sekundären Abschnitts (24) des aufblasbaren Elements (12) gefaltet und zwischen der Stützvorrichtung (30) und dem primären Abschnitt (22) des aufblasbaren Elements (12) hindurchgeführt wird, um den Aufnahmesitz (32) zu erreichen.

19. Montageverfahren nach Anspruch 17 oder 18, wobei nach dem Aufblasen des aufblasbaren Elements (12) der Gasgenerator (14) ersetzt wird, indem der Teil des sekundären Abschnitts (24) des aufblasbaren Elements (12) mit dem Kopplungsgegenelement (20) in dem Aufnahmesitz (32) fixiert gehalten wird.

Revendications

1. Dispositif de protection portable (10) comprenant au moins un élément gonflable (12), un générateur de gaz (14) et un dispositif d'accouplement (16) pour

accoupler le générateur de gaz (14) à l'élément gonflable (12), dans lequel le dispositif d'accouplement (16) comporte un élément d'accouplement (18) associé au générateur de gaz (14) et un contre-élément d'accouplement (20) associé à l'élément gonflable (12), dans lequel le dispositif de protection portable (10) comprend un dispositif de support (30) définissant un siège de réception (32) pour recevoir le générateur de gaz (14) avec l'élément d'accouplement (18) respectif, et l'élément gonflable (12) comporte au moins une partie primaire (22) de l'élément gonflable (12) et une partie secondaire (24) de l'élément gonflable (12) reliée d'une seule pièce à la partie primaire (22), la partie secondaire (24) de l'élément gonflable (12) étant pourvue dudit contre-élément d'accouplement (20), le dispositif de protection portable étant **caractérisé en ce que**, le dispositif de support (30) est au moins partiellement superposé à la partie primaire (22) de l'élément gonflable (12) pour former une structure multicouche et la partie secondaire (24) fait saillie par rapport audit dispositif de support (30), ladite partie secondaire (24) de l'élément gonflable (12) étant dans un état plié ou renversé, ou dans un état de pliage ou de renversement, vers le dispositif de support (30), l'état de pliage ou de renversement correspondant à un état de logement dudit contre-élément d'accouplement (20) dans ledit siège de réception (32).

2. Dispositif de protection portable (10) selon la revendication 1, dans lequel la partie secondaire (24) de l'élément gonflable (12) sert de liaison entre la partie primaire (22) de l'élément gonflable (12) et le générateur de gaz (14).

3. Dispositif de protection portable (10) selon la revendication 1 ou 2, dans lequel la partie secondaire (24) de l'élément gonflable (12) est une partie de bord de la partie primaire (22) de l'élément gonflable (12).

4. Dispositif de protection portable (10) selon la revendication 1 ou 2, dans lequel la partie secondaire (24) de l'élément gonflable (12) définit une chambre unique avec ladite partie primaire (22) de l'élément gonflable (12).

5. Dispositif de protection portable (10) selon l'une quelconque des revendications précédentes, dans lequel la partie secondaire (24) de l'élément gonflable (12) est, ou correspond à, une découpe ou une partie résiduelle de l'élément gonflable (12).

6. Dispositif de protection portable (10) selon l'une quelconque des revendications précédentes, dans lequel l'état de renversement ou de pliage est un état dans lequel la partie secondaire est pliée ou renversée sur elle-même, c'est-à-dire qu'elle fait saillie de la partie primaire et est repliée par rapport à la partie

- primaire.
7. Dispositif de protection portable (10) selon l'une quelconque des revendications précédentes, dans lequel l'état renversé ou plié est un état dans lequel une part de la partie secondaire (24) de l'élément gonflable (12) est pliée à 180° par rapport à une autre part de la partie secondaire (24) de l'élément gonflable (12), et/ou dans lequel la partie secondaire (24) de l'élément gonflable (12) est pliée à 180° par rapport à la partie primaire (22) de l'élément gonflable (12).
8. Dispositif de protection portable (10) selon l'une quelconque des revendications précédentes, dans lequel l'élément gonflable (12) comporte une part de cou (121) destinée à être placée en regard de la région de cou d'un utilisateur, et ladite partie secondaire (24) de l'élément gonflable (12) est un appendice faisant saillie de ladite part de cou (121).
9. Dispositif de protection portable (10) selon la revendication précédente, dans lequel l'élément gonflable (12) présente une partie rachidienne ou dorsale (126) destinée à être placée le long d'une région dorsale, et dans lequel ladite partie primaire (22) de l'élément gonflable (12) fait partie de la partie rachidienne (126) sous-jacente au dispositif de support (30).
10. Dispositif de protection portable (10) selon l'une quelconque des revendications précédentes, dans lequel le dispositif de protection portable (10) définit une zone côté utilisateur (38), et ladite partie primaire (22) de l'élément gonflable (12) est disposée du côté de ladite zone côté utilisateur (38) par rapport au dispositif de support (30) et une part de ladite partie secondaire à l'état plié ou renversé est insérée entre ledit dispositif de support (30) et la partie primaire (22).
11. Dispositif de protection portable (10) selon la revendication précédente, dans lequel ladite partie secondaire (24) de l'élément gonflable (12) fait saillie par rapport au dispositif de support (30) vers une zone de cou.
12. Dispositif de protection portable (10) selon l'une quelconque des revendications précédentes, dans lequel le dispositif de support (30) présente une ouverture traversante (40) conçue pour permettre l'accès audit siège de réception (32) et est adapté pour recevoir une part de la partie secondaire (24) portant le contre-élément d'accouplement (20) ou uniquement le contre-élément d'accouplement (20).
13. Dispositif de protection portable (10) selon les revendications 10 et 12, ou 11 et 12, dans lequel l'ouverture traversante (40) est disposée dans ladite zone côté utilisateur (38), et la partie secondaire (24) de l'élément gonflable (12) est partiellement disposée entre le dispositif de support (30) et la partie primaire (22) de l'élément gonflable (12).
14. Dispositif de protection portable (10) selon les revendications 10 et 12, ou 11 et 12, ou selon la revendication 13, dans lequel le siège de réception (32) est accessible à un utilisateur depuis le côté extérieur opposé à la zone côté utilisateur (38).
15. Dispositif de protection portable (10) selon l'une quelconque des revendications précédentes, dans lequel le dispositif de support (30) est conçu pour supporter en outre une unité de commande pour commander le gonflage de l'élément gonflable (12).
16. Article portable (100) tel qu'un vêtement, comprenant un dispositif de protection portable (10) selon l'une quelconque des revendications précédentes.
17. Procédé d'assemblage permettant d'assembler un dispositif de protection portable (10) selon l'une quelconque des revendications 1 à 15, comprenant au moins un élément gonflable (12) et un générateur de gaz (14) ; le procédé comprenant les étapes consistant à :
- équiper le générateur de gaz (14) d'un élément d'accouplement (18) ;
 - placer le générateur de gaz (14) dans un siège de réception (32) d'un dispositif de support (30) et placer le dispositif de support (30) sur une partie primaire (22) de l'élément gonflable (12), de sorte qu'une partie secondaire (24) de l'élément gonflable (12) fait saillie du dispositif de support (30) ;
 - plier la partie secondaire (24) de l'élément gonflable (12) vers le dispositif de support (30) de sorte qu'au moins une partie de ladite partie secondaire (24) de l'élément gonflable (12) fait saillie du siège de réception (32) ou fait face à celui-ci et fournir ladite part de ladite partie secondaire (24) de l'élément gonflable (12) avec un contre-élément d'accouplement (20) ;
 - accoupler le contre-élément d'accouplement (20) avec l'élément d'accouplement (18) associé au générateur de gaz (14).
18. Procédé d'assemblage selon la revendication 17, dans lequel la part de ladite partie secondaire (24) de l'élément gonflable (12) est pliée et passée entre le dispositif de support (30) et la partie primaire (22) de l'élément gonflable (12) de manière à atteindre ledit siège de réception (32).
19. Procédé d'assemblage selon la revendication 17 ou

18, dans lequel, après le gonflage de l'élément gonflable (12), le générateur de gaz (14) est remplacé en maintenant la part de ladite partie secondaire (24) de l'élément gonflable (12) fixée à l'intérieur du siège de réception (32) avec ledit contre-élément d'accouplement (20). 5

10

15

20

25

30

35

40

45

50

55

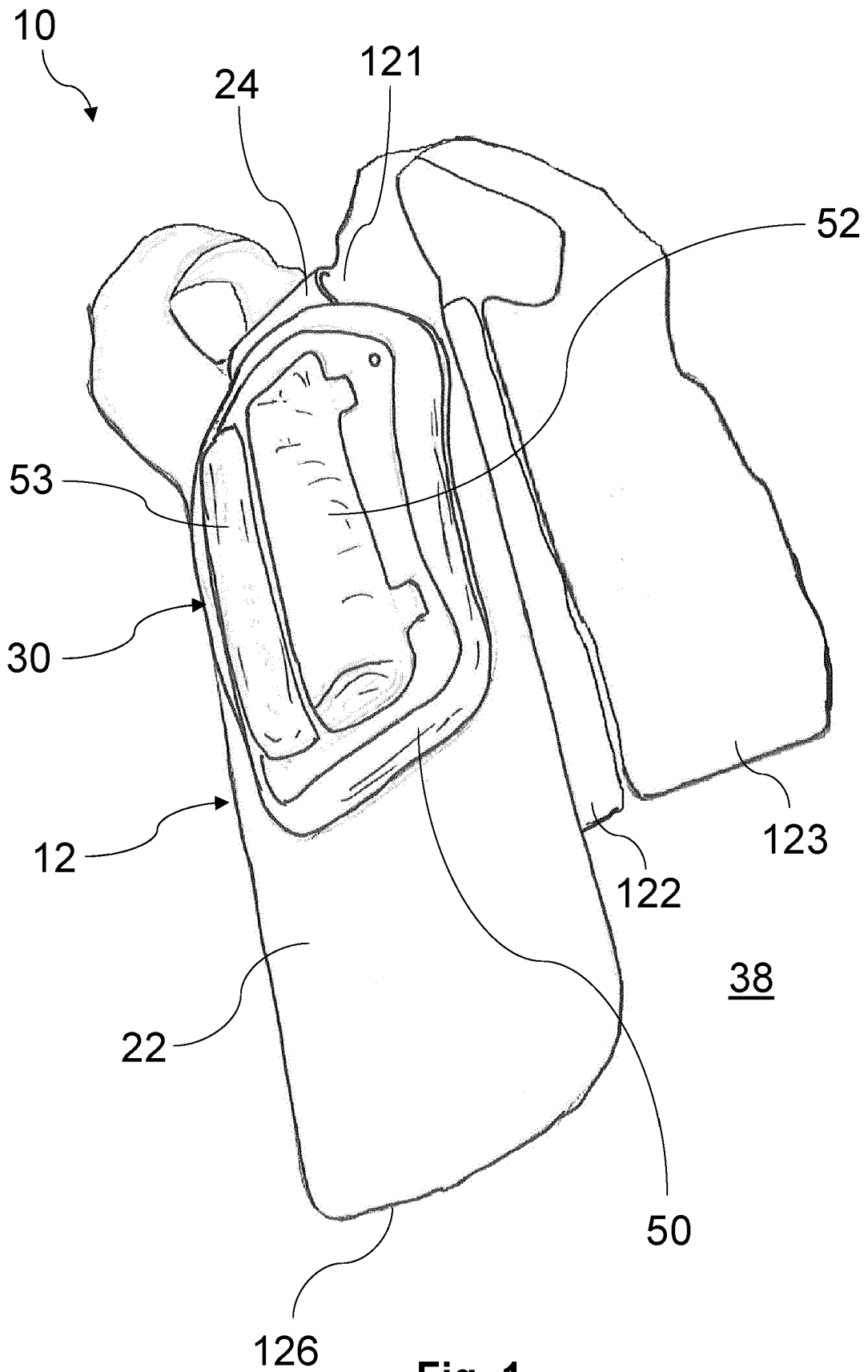

Fig. 1

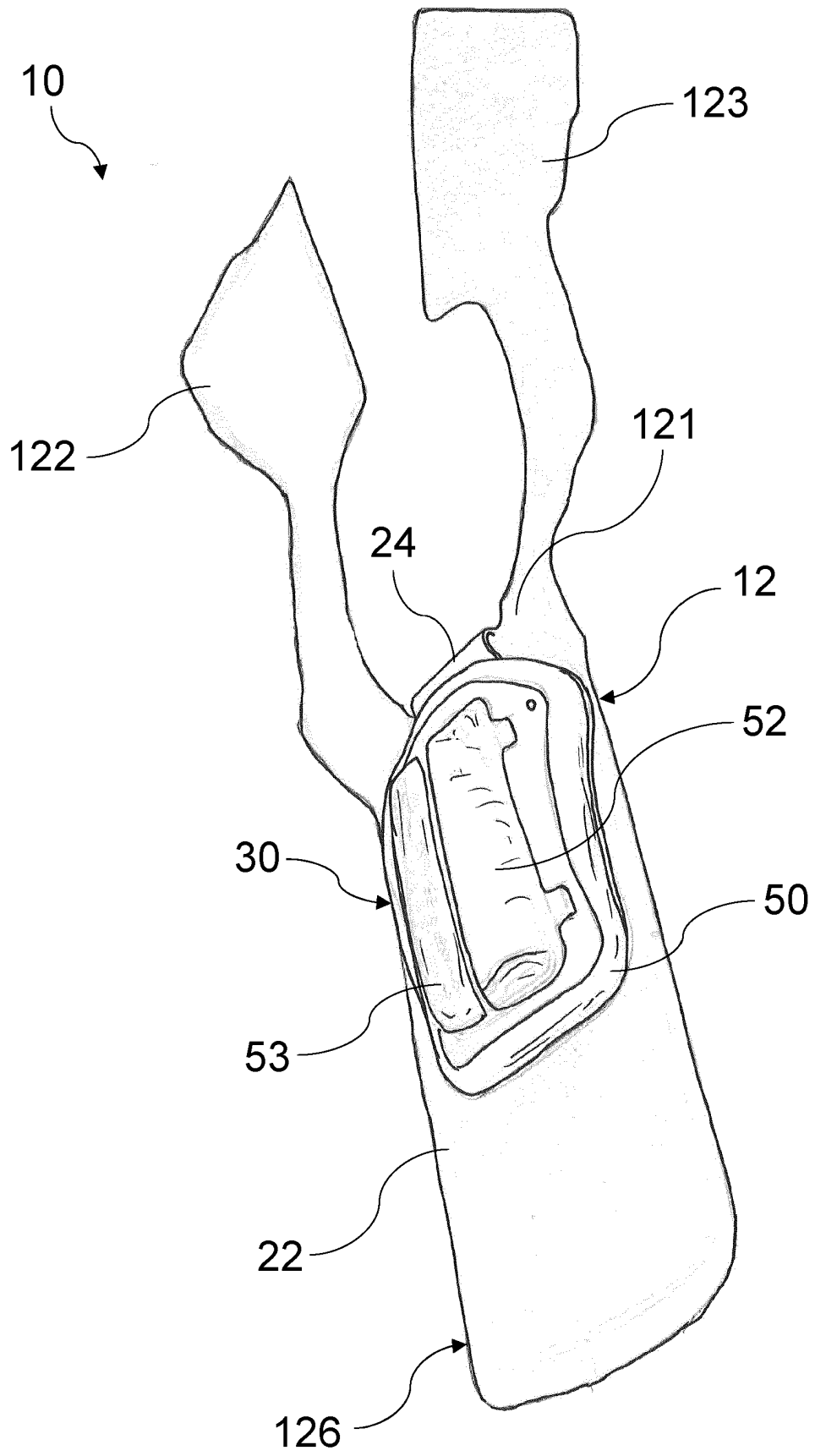

Fig. 2

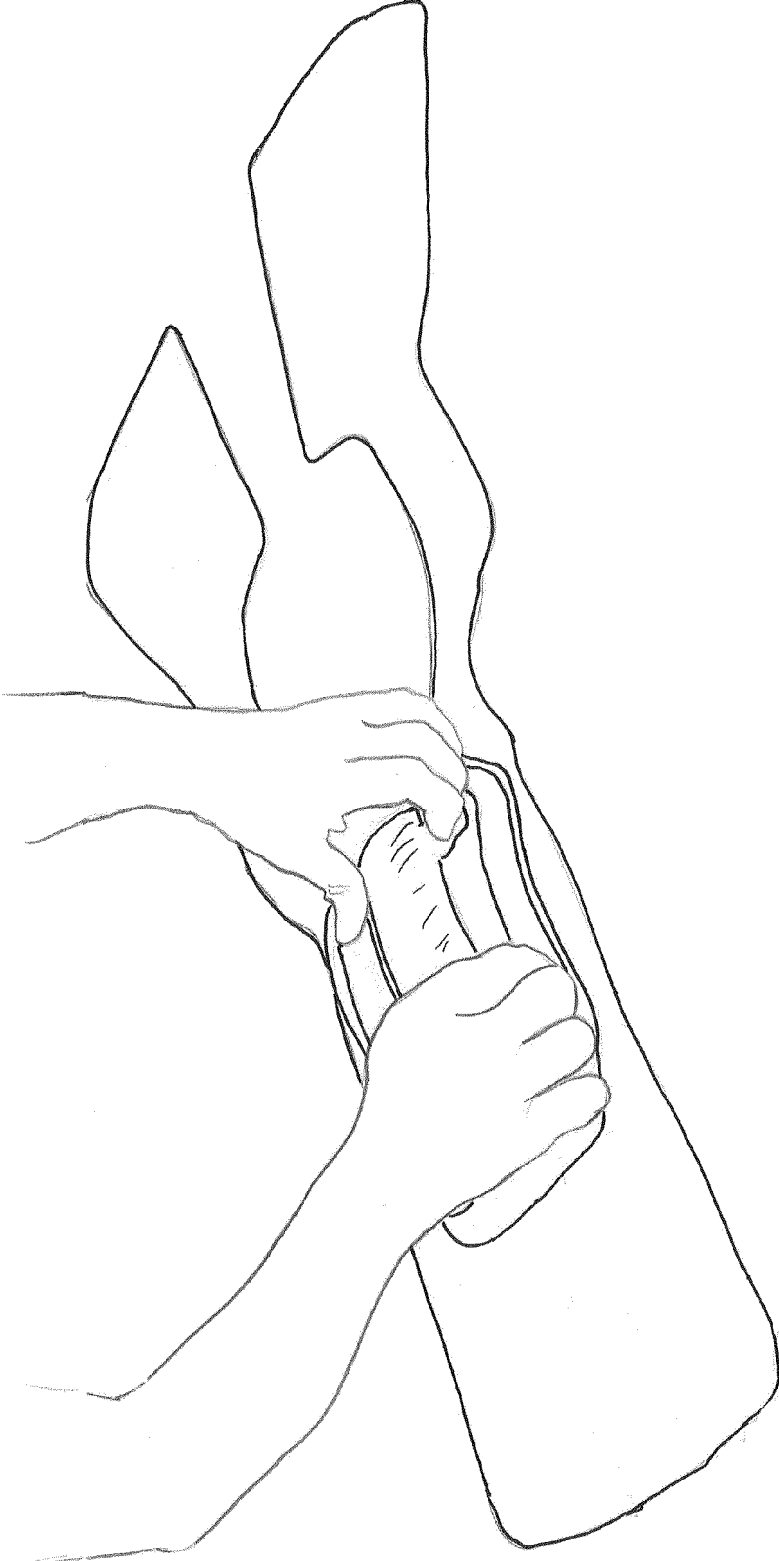

Fig. 3

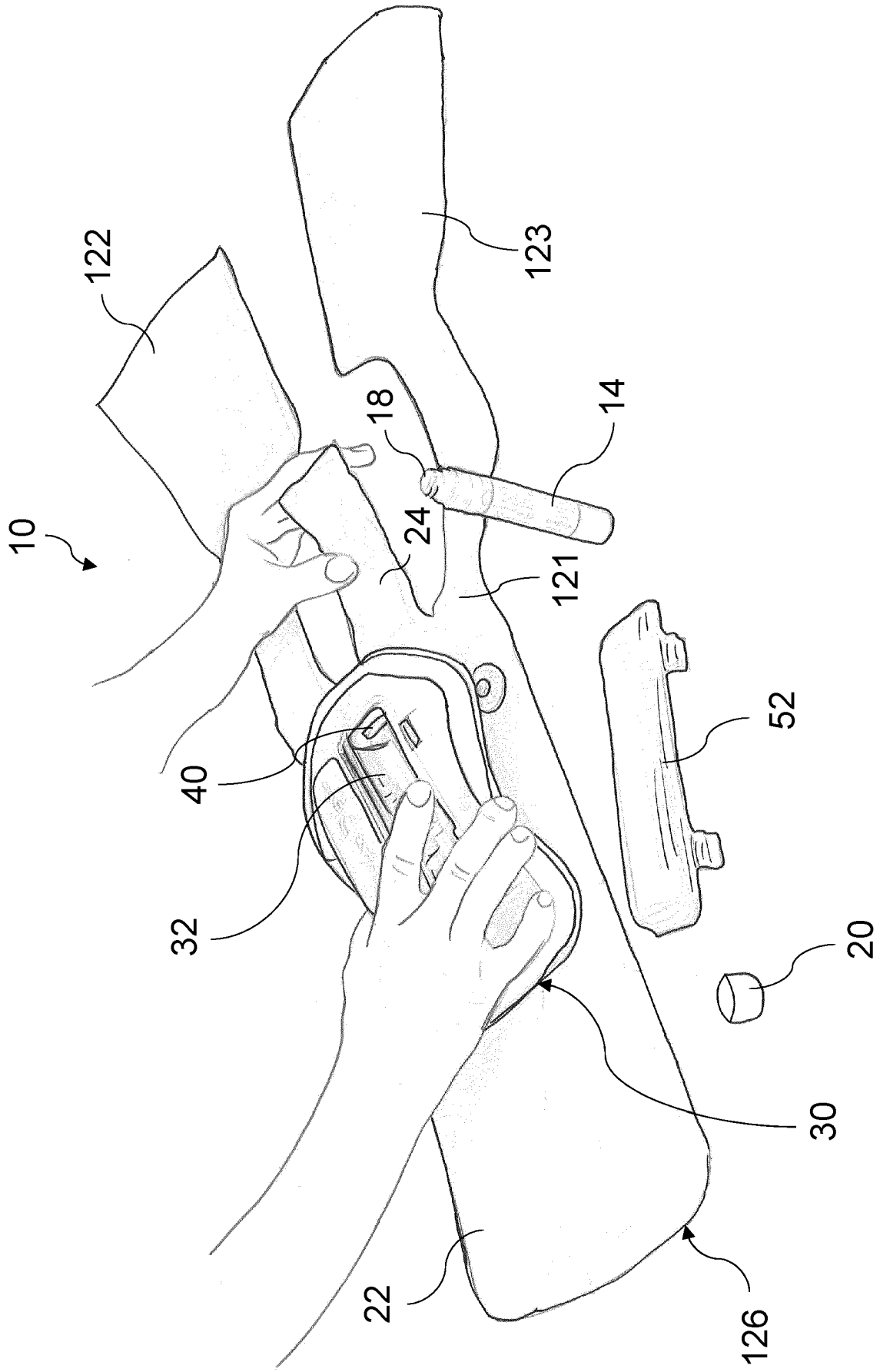

Fig. 4

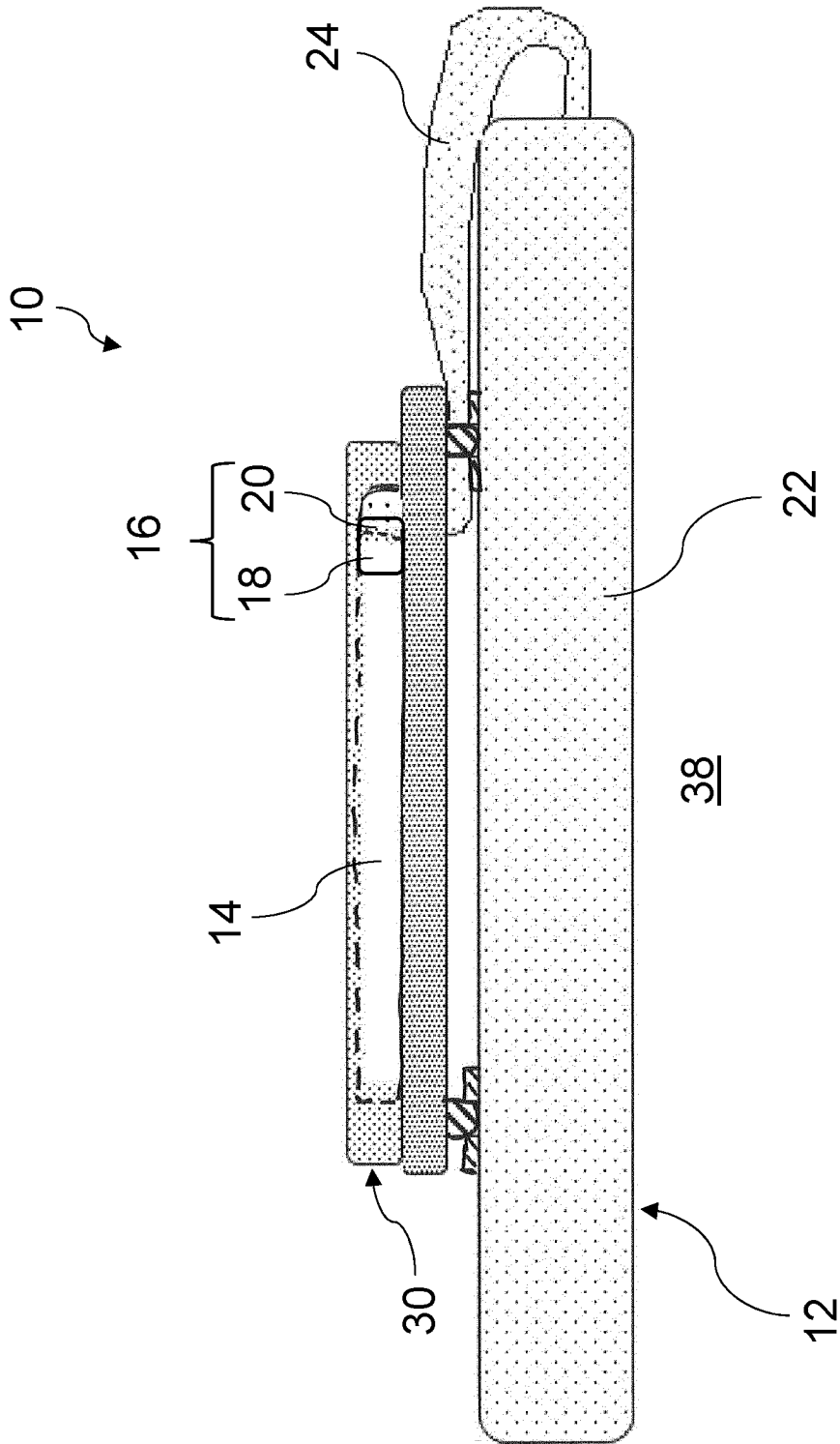

Fig.5

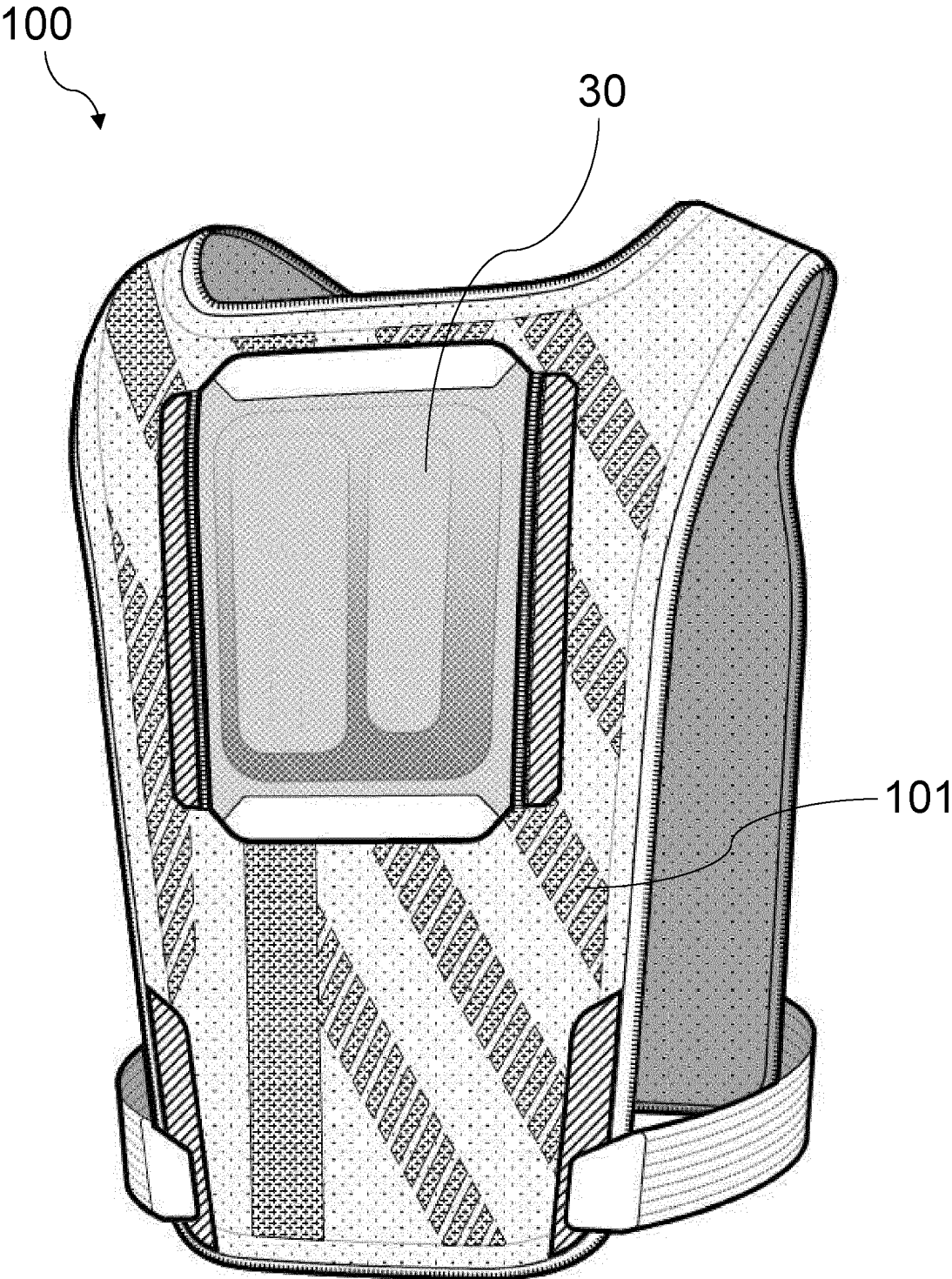

Fig. 6

REFERENCES CITED IN THE DESCRIPTION

This list of references cited by the applicant is for the reader's convenience only. It does not form part of the European patent document. Even though great care has been taken in compiling the references, errors or omissions cannot be excluded and the EPO disclaims all liability in this regard.

Patent documents cited in the description

- KR 20120102434 A [0009]
- WO IB2009055512 A [0062]
- IT 2009000547 W [0062]