



- (51) **International Patent Classification:**
E06B 9/06 (2006.01)
- (21) **International Application Number:**
PCT/RO2019/000032
- (22) **International Filing Date:**
26 December 2019 (26.12.2019)
- (25) **Filing Language:** English
- (26) **Publication Language:** English
- (30) **Priority Data:**
a 2018 01146 28 December 2018 (28.12.2018) RO
- (72) **Inventor; and**
(71) **Applicant: MAURER, Simon-Andreas** [RO/RO]; Str. Albatrosului nr. 11, bl. 11, ap. 23, Jud. Braşov, Braşov (RO).
- (74) **Agent: FÂNTÂNĂ RAUL SORIN & ASOC. SRL;** Str. 9Mai nr., bloc 4, sc. D, apt. 3, cod 500209, Braşov, Jud. Braşov (RO).
- (81) **Designated States** (*unless otherwise indicated, for every kind of national protection available*): AE, AG, AL, AM, AO, AT, AU, AZ, BA, BB, BG, BH, BN, BR, BW, BY, BZ, CA, CH, CL, CN, CO, CR, CU, CZ, DE, DJ, DK, DM, DO, DZ, EC, EE, EG, ES, FI, GB, GD, GE, GH, GM, GT, HN, HR, HU, ID, IL, IN, IR, IS, JO, JP, KE, KG, KH, KN, KP, KR, KW, KZ, LA, LC, LK, LR, LS, LU, LY, MA, MD, ME, MG, MK, MN, MW, MX, MY, MZ, NA, NG, NI, NO, NZ, OM, PA, PE, PG, PH, PL, PT, QA, RO, RS, RU, RW, SA, SC, SD, SE, SG, SK, SL, SM, ST, SV, SY, TH, TJ, TM, TN, TR, TT, TZ, UA, UG, US, UZ, VC, VN, ZA, ZM, ZW.
- (84) **Designated States** (*unless otherwise indicated, for every kind of regional protection available*): ARIPO (BW, GH, GM, KE, LR, LS, MW, MZ, NA, RW, SD, SL, ST, SZ, TZ,

(54) **Title:** RETRACTABLE PARTITION WALL

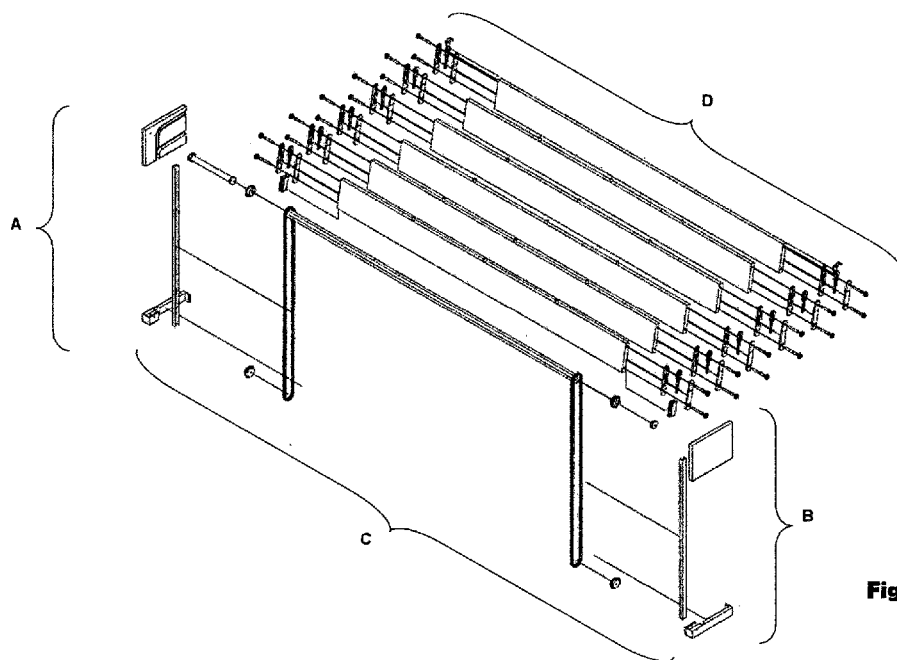

Fig.1

(57) **Abstract:** The invention refers to a retractable modular partition wall that may be used to partition residential spaces, or it may operate as a garage door that is mounted on two parallel walls of a premises and consists (Fig. 1.1) of an *assembled left-side runway*, A, that is fastened with the aid of the some known fastening elements, such as dowels and screws, on the conventionally left wall of the premises, an *assembled right-side runway*, B, mirroring the left-side runway, A, and which is fastened with some known fastening elements, such as dowels and screws, on the conventionally right-side wall of the premises, a *drive mechanism*, C, and several assembled movable panels, D. The *retractable modular partition wall* is conceived so that: i) when used inside or outside a building, in retracted state, it looks like a horizontal beam, whereas in expanded state it operates as a wall; ii) when used outside a building, in retracted state it looks like a horizontal beam, whereas in expanded state, it operates as a garage door; iii) it is operated through electronic command and, in case of power failure, it can be driven manually; iv) when used in a premises, whether inside or outside a



UG, ZM, ZW), Eurasian (AM, AZ, BY, KG, KZ, RU, TJ, TM), European (AL, AT, BE, BG, CH, CY, CZ, DE, DK, EE, ES, FI, FR, GB, GR, HR, HU, IE, IS, IT, LT, LU, LV, MC, MK, MT, NL, NO, PL, PT, RO, RS, SE, SI, SK, SM, TR), OAPI (BF, BJ, CF, CG, CI, CM, GA, GN, GQ, GW, KM, ML, MR, NE, SN, TD, TG).

Published:

- *with international search report (Art. 21(3))*
- *with amended claims (Art. 19(1))*

(88) Date of publication of the international search report:

12 November 2020 (12.11.2020)

Date of publication of the amended claims:

30 December 2020 (30.12.2020)

(15) Information about Correction:

see Notice of 24 September 2020 (24.09.2020)

Previous Correction:

see Notice of 20 August 2020 (20.08.2020)

RETRACTABLE PARTITION WALL

The field of this invention is a retractable wall that is used both for the partition of residential spaces and as a garage door.

A solution of partition of the rooms in residential apartments through glass partition walls already exists. It is an inner wall built of glass panels mounted on a wooden or metal framework. It has the **disadvantage** that, when open, it takes some of the useful space; moreover, it does not provide intimacy, as it does not offer soundproofing.

Another system of movable / removable partitioning walls is **known**, which is field of patent **US2008209827** and is used to partition a room, including a wall component and some spaced-apart pressure feet – at the top of the wall – for pressing against a track positioned between the top of the wall and the ceiling and some additional spaced-apart pressure feet at the bottom of the wall for pressing against a track positioned between the bottom of the wall and the floor. This wall is positioned temporarily, securely and rigidly at a selected location in a room and, subsequently, it may be removed without substantial damage to the ceiling, floor or walls. There are **some disadvantages** of this wall system: i) it can only be used indoor; ii) installation and removal requires considerable time length; iii) additional storage space is needed after the components are folded and iv) it is not a soundproofing system.

Another horizontal garage door system is **also known**, which makes the scope of patent **US2017328105**. It consists of several panels that are connected pivotally to the adjacent side edges; the multiple panels are suspended on a top rail that includes a first straight portion, then a curved portion and a second straight portion. An electromotor is positioned at the first end of the first straight portion, a tensioning mechanism is positioned on a first panel and a gear mechanism is positioned at the second end of the first straight portion. A connecting band connects the electromotor, the gear mechanism and the tensioning mechanism to form a loop along the length of the top rail. The motor drives the connecting band so that the multiple panels move between a closed position, in which the panels are received substantially in the first straight portion, and an open position, in which the panels

are received substantially in the second straight portion. **The disadvantages** of this system are the following: i) the garage opens by practically moving the panels that the door system is made of into a wall that is parallel to the wall of the space of the second straight portion, ii) the system does not offer soundproofing or thermal insulation.

Another garage door system **is known** that is made of horizontal panels that glide into two parallel guides through a system of springs and counterweights driven manually or electrically, the guides going forth on the ceiling of the garage, so that, when the panels are lifted, they glide on the ceiling of the garage. **The disadvantages** of this solution are the following: i) the guides are visible permanently, both on the vertical walls and on the ceiling and additional unaesthetic storage space is required when the panels are retracted to the ceiling, ii) this solution cannot be adapted for indoor premises and iii) the system is not soundproof.

The technical problems that this invention solves:

- i) The setting-up of a retractable partition wall that can be used inside or outside a building so that, when retracted, it looks like a horizontal beam stuck on the ceiling and, when expanded, it operates as a wall.
- ii) The setting-up of a retractable partition wall that is conceived so that, when used inside a building and retracted, it looks like a horizontal beam stuck on the ceiling, and when expanded, it operates as a wall or as a garage door;
- iii) The setting up of a retractable partition wall that is conceived in such a manner as to be operated by electronic control and, in case of power failure, to be operated by manual drive.

The advantages of this invention are the following: whether it is used as an indoor wall, as an outdoor wall, or as a garage door, after installation, no additional storage space is required after the components are stacked; this is a soundproofing and thermal insulating system; after installation, it can either be operated by electronic control, or driven manually, its retracting or expanding only requiring minimal or no effort at all; in certain situations, when expanded, it may be used as a projection screen, or as an advertising surface.

Next, an example of execution of this invention is given also with reference to the following figures that represent:

- **fig.1.1** – a perspective exploded view of the movable retractable wall
- **fig.1.2** – a perspective isometric view of construction of the assembled retractable partition wall
- **fig.1.3** – a W presentation detail of the manner of stacking of the panels of the
- **fig.1a'** – an exploded isometric view of the conventionally right end of the driving unit
- **fig.1a''** – an assembled isometric view of the conventionally right end of the driving mechanism
- **fig.1b'** – an exploded isometric view of the conventionally left end of the driving unit
- **fig.1b''** – an assembled isometric view of the conventionally left end of the driving unit
- **fig.2a** – a front view of the assembled left-side runway
- **fig.2b** - a front view of the assembled right-side runway
- **fig.2a'** - an isometric view of the bridle of the assembled left-side runway
- **fig.2b'** - an isometric view of the bridle of the assembled right-side runway
- **fig.3.1** – a front view of the left-side storage panel
- **fig.3.2** – a X view of the left-side storage panel
- **fig.3.3** – an isometric view of the left-side storage panel to highlight the shape of the slots
- **fig.4.1** – a front view of the right-side storage panel
- **fig.4.2** – a Y view of the right-side storage panel
- **fig.4.3** – an isometric view of the right-side storage panel to highlight the shape of the slots
- **fig.5** – a view and details of the assembled intermediary panel
- **fig.6, fig.6', fig.6''** - an isometric view of the assembled intermediary distance module
- **fig.7** - an isometric view of the assembled bottom distance module
- **fig.8** - an isometric view of the assembled top distance module
- **fig. 9.1, fig. 9.1', fig. 9.2, fig. 9.2', fig. 9.3, fig. 9.3', fig. 9.3'', fig. 9.4, fig. 9.5, fig. 9.6, fig. 9.6', fig. 9.7, fig. 9.7', fig. 9.7''** – stages and details of the assembling
- **fig.10** – isometric detail of the modular panel when lifted completely
- **fig.11** – isometric detail of the manually driven mechanism

- **fig.12** – isometric detail of the upper part of the retractable wall when expanded to highlight the **alpha > 0** installation condition

According to the invention, the vertical movable retractable wall system is mounted on two parallel walls of the premises and it consists (**fig.1.1, fig.1.2, fig.1.3**) of an assembled left-side runway, A, that is fastened with the aid of the some known fastening elements, such as dowels and screws, on the conventionally left wall of the premises, an assembled right-side runway, B, mirroring the left-side runway, A, and which is fastened with some known fastening elements, such as dowels and screws, on the conventionally right-side wall of the premises, a drive mechanism, C, and several assembled movable panels, D; the assembled left-side runway, A, consists of (**fig. 2a, fig. 2a'**) a left bridle, 1, fastened at the base of the conventionally left-side wall, a vertical runway, 2, of **hc** height, **lc** width and **gc** thickness, with a slot, **a**, of **a1 < gc** of depth, a vertical runway, 2, that lies on top of and is stuck to the left bridle, 1, and a left-side storage panel, 3, (**fig.3.1, fig.3.2, fig.3.3**), of **hp** height, **lp** width and **gp=gc** thickness, stuck to the ceiling of the premises, on top of and going onward from the runway, 2, in which an F-shaped slot is made that, vertically and going forth from the bottom branch of the letter „F”, continues the slot, **a**, of the vertical runway, 2, at the same depth, **a1**; the continuation of the vertical of the slot, **a**, and the top branch of the letter “F” is a slot, **as**, of the same width, **gp**, but having a **a2 < a1** depth;

The two slots that form the horizontal branches of the letter “F” connect to the vertical slot with a **rc** radius and continue under a slope of **β** angle, also called “gravitational fall angle”; the vertical distance between the two slots is **p**;

we note with **e** the distance between the bottom edge of the left-side storage panel, 3, and the peak, **b**, between the upper part of the lower slot of the letter “F”, of **a1** depth, and the left side of the slot that continues with the **a2** depth;

in the left bridle, 1, of **hb** height, the **a** slot of the vertical runway, 2, of **a1** depth, continuing with the **ab ≤ hb** depth; the anterior end of the left bridle, 1, has a milled slot, **c**, and a hole, **d**, in which a sprocket wheel, 5, for Gall chain can be assembled on an axle, 4.

in the left-side storage panel, 3, on the vertical line lifted from the axis of the hole, **d**, in the left bridle, 1, a square orifice, **m**, has been made at the **md** distance from the lower side of the left-side storage panel, 3;

the assembled right-side runway, B, (fig. 2b, fig. 2b') mirroring the assembled left-side runway, A, is made of a right-side bridle, 1', fastened on the conventionally right-side wall, a vertical runway, 2', of h_c height, l_c width and g_c thickness, with a slot, a' , of $a_1 < g_c$ depth, a vertical runway, 2', that lies on top of and is stuck to the left bridle, 1, and a left-side storage panel, 3', (fig. 4.1, fig. 4.2, fig. 3.3), of h_p height, l_p width and $g_p = g_c$ thickness, stuck to the ceiling of the premises, on top of and going onward from the runway, 2', in which a "reversed F-shaped" slot is made that, vertically and going forth from the bottom branch of the letter „F", continues the slot, a' , of the vertical runway, 2', at the same depth, a_1 ; the continuation of the vertical of the slot, a' , and the top branch of the "reversed letter F" is a slot, as' , of the same width, g_p , but having a $a_2 < a_1$ depth;

The two slots that form the horizontal branches of the "reversed letter F" connect to the vertical slot with a r_c radius and continue under a slope of β angle, also called "gravitational fall angle"; the vertical distance between the two slots is p ;

we note with e the distance between the bottom edge of the right-side storage panel, 3', and the peak, b' , between the upper part of the lower slot of the "reversed letter F", of a_1 depth, and the left side of the slot, as' , that continues with the a_2 depth;

in the right bridle, 1', of h_b height, the a' slot, of a_1 depth of the vertical runway, 2', continuing with the $ab \leq h_b$ depth; the anterior end of the left bridle, 1', has a milled slot, c' , and there is a hole, d' , in which a sprocket wheel, 5', for Gall chain, identical to the sprocket wheel 5, can be assembled on an axle, 4'.

in the right-side storage panel, 3', on the vertical line lifted from the axis of the hole, d' , in the right bridle, 1', a square orifice, m' , has been made at the md distance from the lower side of the right-side storage panel, 3';

The driving unit, C (Fig. 1a', Fig. 1a'', Fig. 1b', Fig. 1b'', Fig. 2a', Fig. 2b', Fig.5) consists of a polygonal tube, 6, for example an octagonal one, in which,

- Through the conventionally left end, a special motor, 7, is inserted, that, at the right end, has a polygonal-headed axle, for example an octagonal one, 8, that slides into the tube, 6, as far as a limiting impression, u , made on the tube; after the motor, 7, is inserted, at the conventionally left end of the tube, 6, a distance piece, 9, is glided in, which, on the outside, has the section of the tube, 6, and on the inside, has the exterior diameter of the motor, with a little clearance; a sprocket wheel for Gall chain, 10, is assembled on the distance piece, 9; a head, bb , of the same section as that of

the square orifice, m , is placed axially on the encasing at the left end of the motor, 7;
the orifice, m , is processed in the left-side storage panel, 3;

- at the conventionally right end of the tube, 6, a distance piece, 9, is glided in, which, on the outside, has the section of the tube, and, at the free end, axially, has a cylindrical head, cc , of the same section as that of the cylindrical orifice, m' , processed in the right-side storage panel, 3'; on the distance piece, 9', a sprocket wheel for Gall chain, 11, is assembled;
- on the sprocket wheel for Gall chain, 10, and the sprocket wheel for Gall chain, 5, an endless Gall chain, 12, is assembled; on the side facing the runway, 2, the Gall chain, 12, has an upper work driving arm, 13, and a lower work driving arm, 23, both placed at an lb distance;
- on the sprocket wheel of the Gall chain, 11, and the sprocket wheel of the Gall chain, 5', an endless Gall chain, 12', is assembled; on the side facing the runway, 2', the Gall chain, 12', has an upper work driving arm, 13', and a lower work driving arm, 23', both placed at an lb distance;
- in the assembly, the Y-Y axis of the upper work driving arm, 13, is the same as the axis of the upper work driving arm, 13' (Fig. 1c')
- in the assembly, the Z-Z axis of the lower work driving arm, 23, is the same as the axis of the lower work driving arm, 23'

The assembled movable panels, D (Fig. 2a, Fig. 2b), consist of an assembled lower panel, E, several assembled intermediary panels, F, and an assembled upper panel, G;

The assembled intermediary panel, F, (Fig. 5, Fig. 6, Fig. 6', Fig. 6'') consists of a panel, 14, of lp length, hp height and gp thickness, which, both in the upper and the lower part, both at a t distance from both edges and in the middle, has an unfair hole, o , of ao depth; it is only in the orifices on the upper part of the panel that some orientation bolts, 15, can be assembled, which are made so that some of them may be bound in the orifices on the upper part of the panel, 15, whereas on the free side of hp height, with the help of an orientation bevel, to , some may be guided and slide into the unfair holes, o , of $ag > bh$ depth, on the lower part of the next panel, when such a panel exists; laterally, on either side of each panel, F, at the x distance (Fig. 5) from the edges on the hp height, there are two orifices, or , in which some bolts, 16 and 17, of an assembled intermediary distance piece, M, are inserted without any clearance; when assembled, the assembled intermediary panel, E, with the

assembled intermediary modules, M_E , to the left and to the right of the panel, 14, may slide on the bearings, 21, on the short bolts, 16, along the as and as' slots, of a_2 depth, and respectively with the bearings, 21, on the long bolts, 17, along the a and a' slots, of a_1 depth;

The assembled lower panel, E, differs from the assembled intermediary panel only in that it has an assembled lower distance piece M_E (Fig. 7) at its ends;

The assembled upper panel, G, differs from the assembled intermediary panel only in that it has an assembled lower distance piece M_G (Fig. 8) at its ends;

The assembled intermediary distance piece (M_F) (Fig.6, Fig.6', Fig.6'') consists of two symmetrical lateral elements (18 and 18'') of L_{md} length, $L_{md} > gp$ width, a compression spring (19), which, when uncompressed, has the l_{arc} length, and, when compressed, has the l_{comp} length, a slide block (20), a short bolt (16), on which a bearing (21) is fastened, and a long bolt (17) on which another bearing (21) is fastened; each of the symmetrical elements (18 and 18'') have some orifices (ot), a gliding slot (cu), that ends at a shoulder (um); the slide block (20) has a longitudinal slot (cln) of l_{can} length and of a width equal to the diameter of the short bolt (16) and an extension (pre) that is worked in such manner that, during assembly, the glide block (20) glides into the gliding slot (cu) under the action of the spring (19); the assembled lateral symmetrical elements (18 and 18''), compression spring (19) and glide block (20) are fastened with some screws (22); the bolts (16 and 17) are assembled through the orifices (ot) and, on these bolts, the bearings (21) are assembled without any clearance;

The assembled lower distance piece (M_E) (Fig. 7) differs from the assembled intermediary distance piece (M_F) in that has two identical and mirroring small face plates (24 and 24') assembled between the bolts (16 and 17), with the screws (22), both plates having a drive slot in them (cm, respectively cm');

The assembled upper distance piece (M_G) (Fig. 8) differs from the assembled intermediary distance piece (M_F) in that a coupler jaw (26) is assembled on the sliding block (20) with a screw bolt (25);

In a second version, the driving unit, C, is completed by a manual driving mechanism, H, (fig. 11) that would be necessary in case the motor, 7, stops working due to a power failure; the manual driving mechanism, H, is mounted, for example, on one of the storage panels, 3 or 3', and it consists of a box, 27, in which a Gall chain sprocket wheel, 28, is engaged together with the Gall chain, 12 or 12', and

laterally with a conveyer worm, 29, fastened on the box, 27, and driven by a lever, 30. The manual drive mechanism, H, is disengaged as long as the motor drive, 7, operates; when the manual drive, H, is preferred, the motor, 7, has to be disengaged.

In a third version, the driving unit, C, is only actuated by the manual driving mechanism, H.

Manner of assembly (Fig. 9.1, Fig. 9.1', Fig. 9.2, Fig. 9.2', Fig. 9.3, Fig. 9.3', Fig. 9.3'', Fig. 9.4, Fig. 9.5, Fig. 9.6, Fig. 9.6', Fig. 9.7, Fig. 9.7', Fig. 9.7''):

- In the initial stage, the assembled left-side runway, A, the assembled right-side runway, B and the driving unit, C, are mounted in the premises – on the walls, columns etc.; the special engine, 7, not being on load, the polygonal-headed axle rotates freely; the Gall chains, 12 and 12', are assembled on the wheels, 10 and 5, respectively 11 and 5', so that the lower work driving arms, 23 and 23', are in the proximity of the Gall chain sprocket wheels, 10 and respectively 11, on the side facing the 2 and respectively 2' runways;
- In the second stage, simultaneously, through the two slots that make the horizontal branches of the letter "F" in the storage panels 3 and 3', the assembled lower panel, E, is inserted: both on the left-side storage panel, 3, and the right-side storage panel, 3', the bearings, 21, on the long bolt, 17, are first inserted in the slot a, then the bearings, 21, on the short bolt, 16, are inserted in the slot as; owing to the fact that $Dis > p$ (Fig. 6'', Fig. 3.1, Fig. 4.1), the assembled lower panel, E, will have an oblique position; owing to the β gravitational fall angle of the runways in the two storage panels, 3 and 3', the assembled lower panel, E, will slide along the slots and will fix the lower work driving arms, 23 respectively 23', in the drive slots, cm, respectively cm', of the small face plates, 24 and 24', which will glide freely in the slots, cm and respectively cm'; the assembled intermediary panels, F, are inserted one by one, in the same manner and, at the end, the assembled upper panel, G, is inserted (Fig. 2a, Fig. 2b);
- In the third stage, by letting the assembled lower panel, E, glide freely, through its own weight, in the vertical runways, 2 and respectively 2', as soon as the downward movement of the assembled lower panel, E, allows it, the first assembled intermediary panel, F, positions itself by gliding with the two assembled intermediary distance pieces, M_F, at the ends, on the sliding blocks, 20, of the assembled lower

panel, E; owing to the springs, 19, the sliding blocks, 20, keep the assembled intermediary panel, F, away from the orientation bolts, 15, that are assembled in the upper part of the assembled lower panel, E, (Fig. 5 and Fig. 6'') at the $Lmd + dep > hp + hb$ distance;

- as soon as the downward movement of the first assembled intermediary panel, F, allows it, the next, assembled intermediary panel, F, positions itself, by gliding with the two assembled intermediary distance pieces, MF, at the ends, on the sliding blocks, 20, of the assembled lower panel, E; owing to the weight of the two previous panels, the first assembled intermediary panel, E, enters, with the unfair holes, o, in the orientation bolts, 15, that are assembled on the upper part of the previous panel; but, owing to the springs, 19, of the previous assembled distance piece, the sliding blocks, 20, keep the next assembled intermediary panel, F, away from the orientation bolts, 15, that are assembled in the upper part of the previous assembled panel, at the same $Lmd + dep > hp + hb$ distance;
- when the assembled upper panel, G, gets in vertical position, the special motor, 7, starts and, through the assembly of pieces of the driving unit, C, actuates the Gall chains, 12 and 12', and the upper work driving arms, 13 and respectively 13', thus coming into contact with and pushing down, on the F direction (Fig. 12.1), the coupler jaws, 26, of the assembled upper distance piece, MG, to the point where the springs, 20, of this last distance piece are completely compressed, to ensure i) the orientation of the assembled upper panel, G, in the orientation bolts, 15, of the one before last panel and ii) the tightening of the entire retractable wall, while complying with the $\alpha > 0$ (at least 2-3 cm) condition (Fig.12), so that the last bearing does not come out from the vertical part of the slot, as and as', in the storage panels, 3 and 3', in other words the vertical part of e size of the slot, a and a'; in this position, between the work driving arms, 23 and respectively 23', and the shoulder of the cm and respectively cm' slots of the small face plates, 24 and 24', a clearance of a few centimetres remains, and the motor, 7, stops through electronic command;
- for the retracting of the modular wall, the engine, 7, is turned on, the Gall chains, 12 and 12', are actuated simultaneously, the upper work driving arms, 13 and 13', stop pushing onto the coupler jaws, 26, of the assembled upper distance piece, MG, releasing the springs, 19, and thus allowing the sliding block, 20, to move the assembled upper panel, F, which goes out of the orientation bolts, 15; the lower

driving arms, **23** and **23'**, get to the shoulders of the drive slots, **cm** and **cm'**, and then drive all the above panels in an upward movement;

- when the assembled upper panel, **G**, enters the left-side storage panel, **3**, and right-side storage panel, **3'**, the next assembled intermediary panel, **F**, in its turn, comes out of the orientation bolts, **15**, of the intermediary panel underneath it, thus being able to enter the left-side, **3**, and right-side, **3'**, storage panels;
- the upward retracting of all the panels in the upper part of the wall ends when the bearings, **21**, on the long bolts, **17**, of the assembled lower panel, **E**, reach the $d_{fin} > 0$ distance from the peak, **b**, between the upper part of the lower slot of the letter "F" of the left-side storage panels, **3**, and right-side storage panels, **3'**, (Fig. 1.1, fig.1.2, Fig. 1.3, Fig. 10).

Bibliography

- patent US2017328105
- patent US2008209827
- patent JP2004278060

AMENDED CLAIMS

received by the International Bureau on 28 October 2020 (28.10.2020)

1. Retractable partition wall conceived to be used inside or outside a building, for closing access openings or openings in general of residential and industrial buildings, with function of separation of environments, mobile walls, darkening, advertising, design, verandas, as well as for furnishing of interiors, etc., basically comprising a removable shutter constituted by a plurality of rigid slats or modular frames (E, F, G) designed to slide along lateral guides (2, 2') using a motor (7), which, when retracted, it has the aspect of a horizontal beam stuck on the ceiling, whereas when expended it operates as a wall, said retractable partition wall being **characterised in that** it consists of an assembled left-side runway (A), that is fastened with the aid of the some known fastening elements, such as dowels and screws, on the conventionally left wall of the premises, an assembled right-side runway (B), mirroring the left-side runway (A) and which is fastened with some known fastening elements, such as dowels and screws, on the conventionally right-side wall of the premises, a drive mechanism (C) and several assembled movable panels (D); the assembled left-side runway (A) consisting (**fig. 2a, fig. 2a'**) of a left bridle (1), fastened at the base of the conventionally left-side wall, a vertical runway (2) of **hc** height, **lc** width and **gc** thickness, with a slot (**a**) of **a1 < gc** of depth a vertical runway (2), that lies on top of and is stuck to the left bridle (1), and a left-side storage panel (3) (fig.3.1, fig.3.2, fig.3.3), of **hp** height, **lp** width and **gp = gc** thickness, stuck to the ceiling of the premises, on top of and going onward from the runway (2); in the left bridle (1), of **hb** height, the (**a**) slot, of **a1** depth of the vertical runway (2) continuing on the **ab ≤ hb** depth; the anterior end of the left bridle (1) has a milled slot (**c**) and a hole (**d**) in which a sprocket wheel (5) for Gall chain can be assembled on an axle (4) ; the leftside storage panel having an "F-shaped" slot, which, vertically and going forth from the bottom branch of the letter „F", continues the slot (**a**) of the vertical runway (2), at the same depth (**a1**); the continuation of the vertical of the slot (**a**) and the top branch of the letter "F" is a slot (**as**) of the same width (**gp**) but having a **a2 < a1** depth; the two slots that form the horizontal branches of

the letter "F" connect to the vertical slot with a **rc** radius and continue under a **β angle**, also called "gravitational fall angle"; the vertical distance between the two slots is **p**; we note with **e** the distance between the bottom edge of the left-side storage panel (**3**), and the peak (**b**) between the upper part of the lower slot of the letter "F", of **a1** depth, and the left side of the slot that continues with the **a2** depth ; in the left-side storage panel (**3**), on the vertical line lifted from the axis of the hole (**d**) in the left bridle (**1**) a square orifice (**m**) has been made at the **md** distance from the lower side of the left-side storage panel (**3**); the assembled right-side runway (**B**), while mirroring the assembled left-side runway (**A**), is made of a right-side bridle (**1'**), fastened on the conventionally rightside wall, a vertical runway (**2'**), of **hc** height, **lc** width and **gc** thickness, with a slot (**a'**) of **a1 < gc** depth, a vertical runway (**2'**), that lies on top of and is stuck to the right bridle (**1'**) and a right-side storage panel (**3'**) (**fig. 4.1, fig. 4.2, fig. 4.3**) of **hp** height, **lp** width and **gp=gc** thickness, stuck to the ceiling of the premises, on top of and going onward from the runway (**2'**), in the right bridle (**1'**) of **hb** height, the slot (**a'**) of **a1** depth of the vertical runway (**2'**) continuing on the **ab ≤ hb** depth; the anterior end of the right bridle (**1'**) has been subjected to a milling process (**c'**) and there is a hole (**d'**) in which a sprocket wheel (**5'**) for Gall chain, identical to the sprocket wheel (**5**) can be assembled on an axle (**4'**) ; in the right-side storage panel (**3'**), on the vertical line lifted from the axis of the hole (**d'**) in the right bridle (**1'**), a square orifice (**m'**) has been made at the **md** distance from the lower side of the right-side storage panel (**3'**); the right-side storage panel has a "reversed F-shaped" slot that, vertically and going forth from the bottom branch of the "reversed letter F" continues the slot (**a'**) of the vertical runway (**2'**) at the same depth (**a1**); the continuation of the vertical of the slot and the top branch of the "reversed letter F" is a slot (**as'**) of the same width, **gp**, but having a **a2 < a1** depth; the two slots that form the horizontal branches of the "reversed letter F" connect to the vertical slot with a **rc** radius and continue under a **β angle**, also called "**gravitational fall angle**"; the vertical distance between the two slots is **p** ; we note with **e** the distance between the bottom edge of the right-side storage panel (**3'**) and the peak (**b'**) between the upper part of the lower slot

of the “reversed letter F” of **a1** depth and the left side of the slot (**as'**) that continues with the **a2** depth ; the driving unit, C, consisting of a polygonal tube (**6**), that in our example is an octagonal one, in which, through the conventionally left end, a special motor (**7**) is inserted, that, at the right end, has a polygonal-headed axle (**8**) that slides into the tube (**6**) as far as a limiting concavity (**u**) (**Fig. 1a'**) made on the tube; after the motor (**7**) is inserted, at the conventionally left end of the tube (**6**), a distance piece (**9**) is glided in, which, on the outside, has the section of the tube (**6**) and on the inside, has the exterior diameter of the motor, with a little clearance; a sprocket wheel for Gall chain (**10**) is assembled on the distance piece (**9**); a head (**bb**) of the same section as that of the square orifice (**m**) is placed axially on the encasing at the left end of the motor (**7**) ; the orifice (**m**) is processed in the left-side storage panel (**3**) ; at the conventionally right end of the tube (**6**), a distance piece (**9**) is glided in, which, on the outside, has the section of the tube, and, at the free end, axially, has a cylindrical head (**cc**) of the same section as that of the cylindrical orifice (**m'**) processed in the right-side storage panel (**3'**) ; on the distance piece (**9'**) a sprocket wheel for Gall chain (**11**) is assembled; on the sprocket wheel for Gall chain (**10**) and the sprocket wheel for Gall chain (**5**), an endless Gall chain (**12**) is assembled; on the side facing the runway (**2**), the Gall chain (**12**) has an upper work driving arm (**13**) and a lower work driving arm (**23**); on the sprocket wheel of the Gall chain (**11**) and the sprocket wheel of the Gall chain (**5'**), an endless Gall chain (**12'**) is assembled; on the side facing the runway (**2'**), the Gall chain (**12'**) has an upper work driving arm (**13'**) and a lower work driving arm (**23'**); in the assembly, the B axis of the upper work driving arm (**13**) is the same as the axis of the upper work driving arm (**13'**) (**Fig. 1c'**); in the assembly, the Z-Z axis of the lower work driving arm (**23**) is the same as the axis of the lower work driving arm (**23'**); the assembled movable panels (D) consisting of an assembled lower panel (**E**) de care, lateral, pe ambele parti, sunt asamblate cate un assembled lower distance piece (**bME**) (**Fig. 7**); several assembled intermediary panels (**F**) de care, lateral, pe ambele parti, sunt asamblate cate un assembled intermediary panel (**F**) and an assembled upper panel (**G**)_de care, lateral, pe ambele

parti, sunt asamblate cate un assembled upper distance piece (**M_g**); the mode of operation / assembly follows the stages as shown below: In the initial stage, the assembled left-side runway (A), the assembled right-side runway (B) and the driving unit (C) are mounted in the premises – on the walls, columns, etc.; the motor (7) being turned off, the polygonal-headed axle rotates freely; the Gall chains, (**12 and 12'**) are assembled on the wheels (**10 and 5**, respectively **11 and 5'**) so that the lower work driving arms (**23 and 23'**) are in the proximity of the Gall chain sprocket wheels (**10 and respectively 11**) on the side facing the runways (**2 and respectively 2'**); In the second stage, simultaneously, through the two slots that make the horizontal branches of the letter “F” in the storage panels (**3 and 3'**), the assembled lower panel (E) is inserted: both on the left-side storage panel (**3**) and the right-side storage panel (**3'**), the bearings (**21**) on the long bolt (**17**) are first inserted in the slot (**a**), then the bearings (**21**) on the short bolt (**16**) are inserted in the slot (**as**); owing to the fact that **Dis > p** (**Fig. 6''**, **Fig. 3.1**, **Fig. 4.1**), the assembled lower panel, E, will have an oblique position; owing to the β gravitational fall angle of the runways in the two storage panels (**3 and 3'**) the assembled lower panel, E, will slide along the slots and will capture the lower work driving arms (**23 respectively 23**) in the drive slots (**cm**, respectively **cm'**) of the small face plates (**24 and 24'**), which will glide freely in the slots (**cm** and respectively **cm'**); the assembled intermediary panels (F), are inserted one by one, in the same manner and, at the end, the assembled upper panel (G) is inserted (**Fig. 2a**, **Fig. 2b**); In the third stage, by letting the assembled lower panel (E) glide freely, through its own weight, in the vertical runways (**2 and respectively 2'**), as soon as the downward movement of the assembled lower panel (E), allows it, the first assembled intermediary panel (F) positions itself by gliding with the two assembled intermediary distance pieces (M_F), at the ends, on the sliding blocks (**20**) of the assembled lower panel (E); owing to the springs (**19**), the sliding blocks (**20**) keep the assembled intermediary panel (F) away from the orientation bolts (**15**) that are assembled in the upper part of the assembled lower panel (E) (**Fig. 5 and Fig. 6''**) at the **Lmd + dep > hpan+hb** distance; as soon as the downward movement of the first

assembled intermediary panel (F) allows it, the next, assembled intermediary panel (F) positions itself, by gliding with the two assembled intermediary distance pieces (M_F) at the ends, on the sliding blocks (20) of the assembled lower panel (E); owing to the weight of the two previous panels, the first assembled intermediary panel (E) enters, with the unfair holes (o) in the orientation bolts (15) that are assembled on the upper part of the previous panel; but, owing to the springs (19) of the previous assembled distance piece, the sliding blocks (20) keep the next assembled intermediary panel (F) away from the orientation bolts (15) that are assembled in the upper part of the previous assembled panel at the same $L_{md} + dep > h_{pan} + hb$ distance; when the assembled upper panel, (G) gets in vertical position, the special motor (7) starts and, through the assembly of pieces of the driving unit (C), actuates the Gall chains (12 and 12') and the upper work driving arms (13 and respectively 13'), thus coming into contact with and pushing down, on the F direction (Fig. 12.1), the coupler jaws (26) of the assembled upper distance piece (M_G) to the point where the springs (20) of this last distance piece are completely compressed to ensure i) the orientation of the assembled upper panel (G) in the orientation bolts (15) of the one before last panel and ii) the tightening of the entire retractable wall, while complying with the $\alpha > 0$ (at least 2-3 cm) condition (Fig.12), so that the last bearing does not come out from the vertical part of the slot (as and as') in the storage panels (3 and 3'), in other words the vertical part of e size of the slot (a and a'); in this position, between the work driving arms (23 and respectively 23') and the shoulder of the (cm and respectively cm') slots of the small face plates (24 and 24') a clearance of a few centimetres remains, and the motor (7) stops through electronic command; for the retracting of the modular wall, the engine (7) is turned on, the Gall chains (12 and 12') are actuated simultaneously, the upper work driving arms (13 and 13') stop pushing onto the coupler jaws (26) of the assembled upper distance piece (M_G), releasing the springs (19), and thus allowing the sliding block (20) to move the assembled upper panel (F), which goes out of the orientation bolts (15); the lower driving arms (23 and 23') get to the shoulders of the drive slots (cm and respectively cm')

and then drive all the above panels in an upward movement; when the assembled upper panel (**G**), enters the left-side storage panel (**3**) and right-side storage panel (**3'**), the next assembled intermediary panel (**F**), in its turn, comes out of the orientation bolts (**15**) of the intermediary panel underneath it, thus being able to enter the left-side (**3**) and right-side (**3'**) storage panels; the retracting of all the panels in the upper part of the retractable wall ends when the bearings (**21**) on the long bolts (**17**) of the assembled lower panel (**E**) reach the $dfin > 0$ distance from the peak (**b**) between the upper part of the lower slot of the letter "F" of the left-side storage panels (**3**) and right-side storage panels (**3'**).

2. Assembled intermediary panel (**F**) according to claim 1, **characterized in that** it consists of a panel (**14**) of **lpan** length, **hpan** height and **gpan** thickness, which, both in the upper and the lower part, both at a **t** distance from both edges and in the middle, has an unfair hole (**o**), of **ao** depth; it is only in orifices on the upper part of the panel that some orientation bolts (**15**) can be assembled, which are made so that some of them may be bound in the orifices on the upper part of the panel (**14**) whereas on the free side of **hp** height, with the help of an orientation bevel (**to**), some may be guided and slide into the unfair holes (**o**), of $ao > bh$ depth, on the lower part of the next panel, when such a panel exists; laterally, on either side of each panel (**F**) at the **x** distance (**Fig. 5**) from the edges on the **hpan** height, there are two orifices (**or**) in which the bolts (**16 and 17**) of an assembled intermediary distance piece (**M_F**) are inserted without any clearance; when assembled, the assembled intermediary panel (**E**), with the assembled intermediary modules (**M_E**) to the left and to the right of the panel (**14**) may slide on the bearings (**21**) on the short bolts (**16**) along the (**as and as'**) slots, of **a2** depth, and respectively with the bearings (**21**) on the long bolts (**17**), along the (**a and a'**) slots of **a1** depth; the assembled intermediary distance piece (**M_F**) consisting of two symmetrical lateral elements (**18 and 18'**) of **Lmd** length, $lmd > gpan$ width, a compression spring (**19**), which, when uncompressed, has the **larc** length, and, when compressed, has the **lcomp** length, a slide block (**20**), a short bolt (**16**), on which a bearing (**21**)

is fastened, and a long bolt (17) on which another bearing (21) is fastened; each of the symmetrical elements (18 and 18') have some orifices (ot), a gliding slot (cu), that ends at a shoulder (um); the slide block (20) has a longitudinal slot (cln) of lcan length and of a width equal to the diameter of the short bolt (16) and an extension (pre) that is worked in such manner that, during assembly, the glide block (20) glides into the gliding slot (cu) under the action of the spring (19); the assembled lateral symmetrical elements (18 and 18'), compression spring (19) and glide block (20) are fastened with some screws (22); the bolts (16 and 17) are assembled through the orifices (ot) and, on them, the bearings (21) are assembled without any clearance ;

3. *Assembled lower panel* (E) according to claim 1 and claim 2, **characterized in that** differs from the assembled intermediary panel in that it has, at its both ends, an assembled lower distance piece (ME); the assembled lower distance piece (ME) differs from the assembled intermediary distance piece (MF) in that it has two identical and mirroring small face plates (24 and 24') assembled between the bolts (16 and 17) with the screws (22), both plates having a drive slot in them (cm, respectively cm') ;
4. *Assembled upper panel* (G) according to claim 1 and claim 2, **characterized in that** differs from the assembled intermediary panel in that it has, at its both ends, an assembled upper distance piece (MG); the assembled upper distance piece (MG) as compared to the assembled intermediary distance piece (MF), it has a coupler jaw (26) that is assembled on the sliding block (20) with a screw bolt (25);

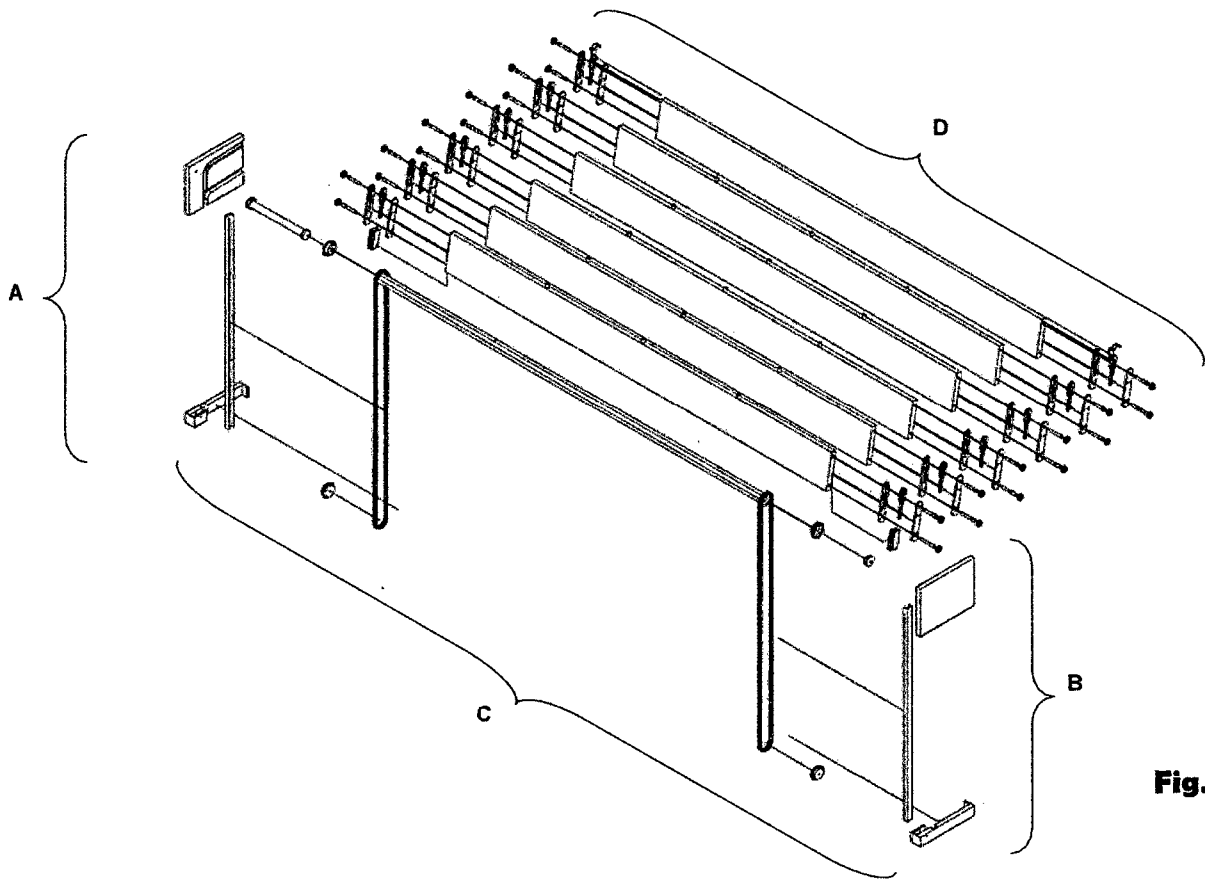
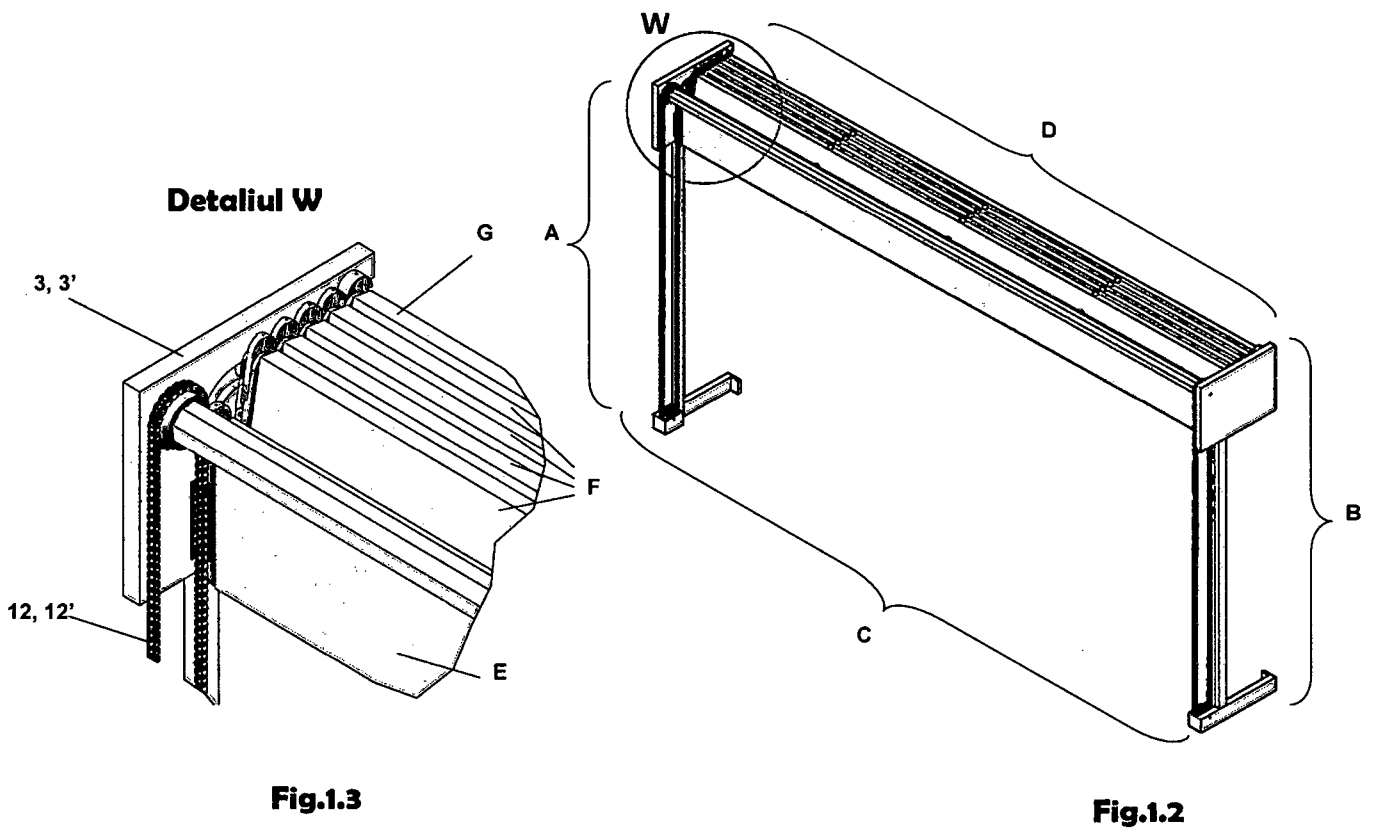
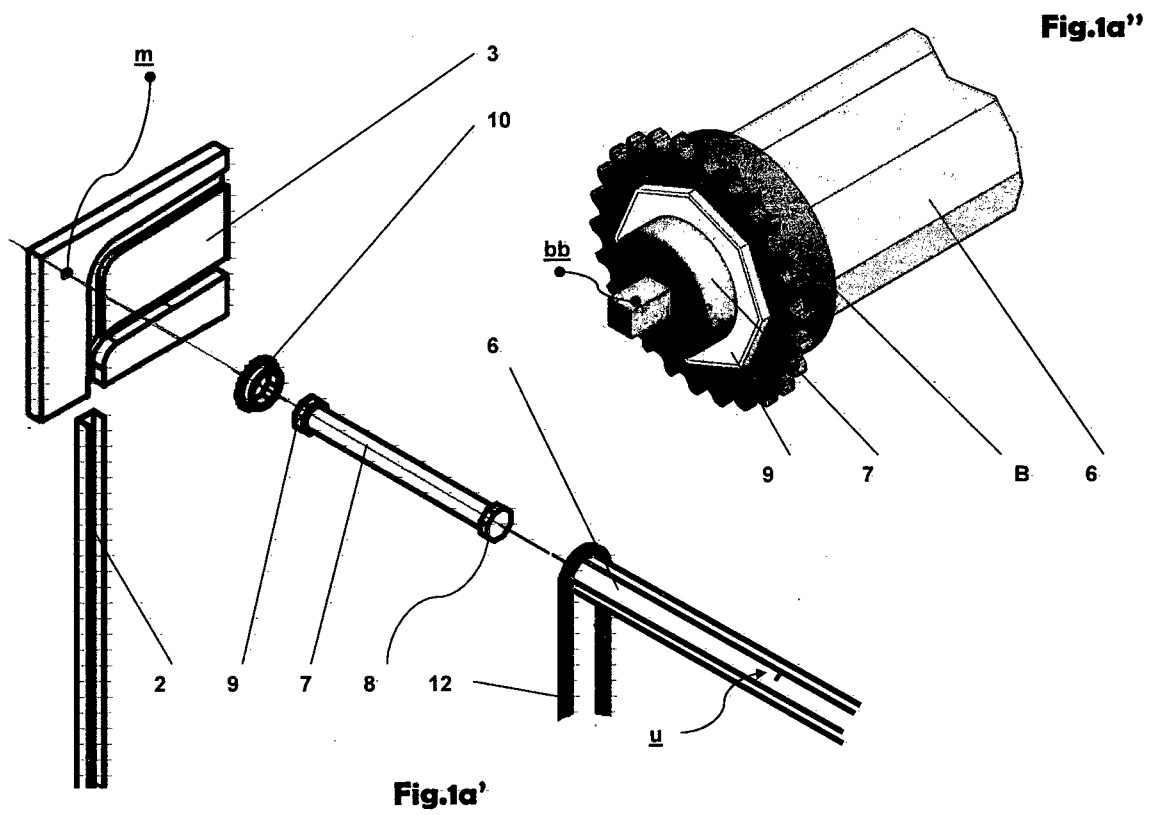

Fig.1





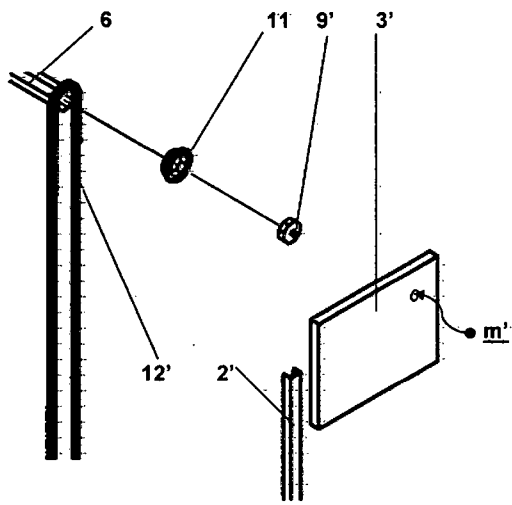

Fig.1b'

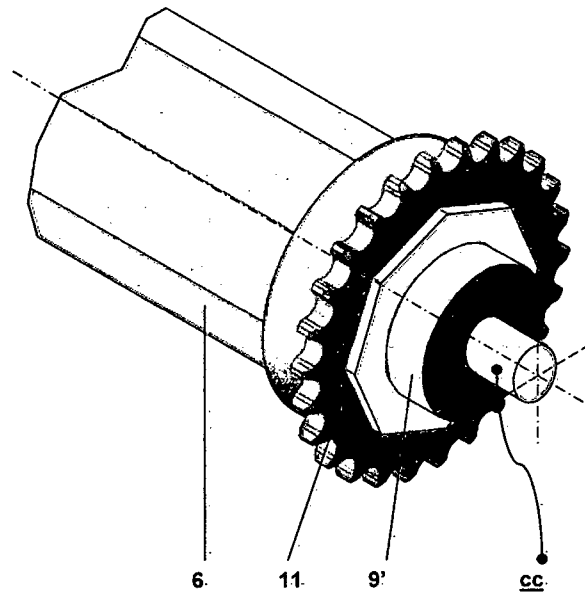

Fig.1b''

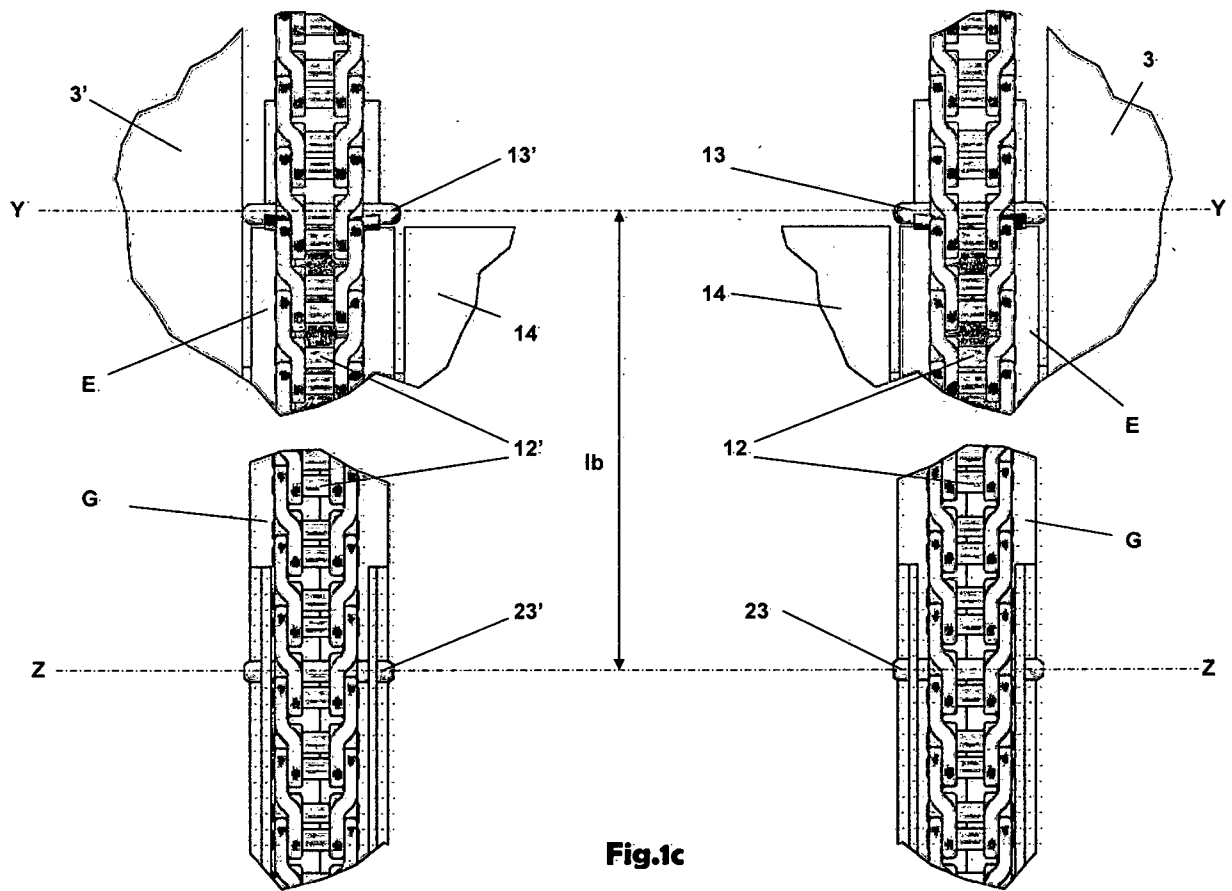

Fig.1c

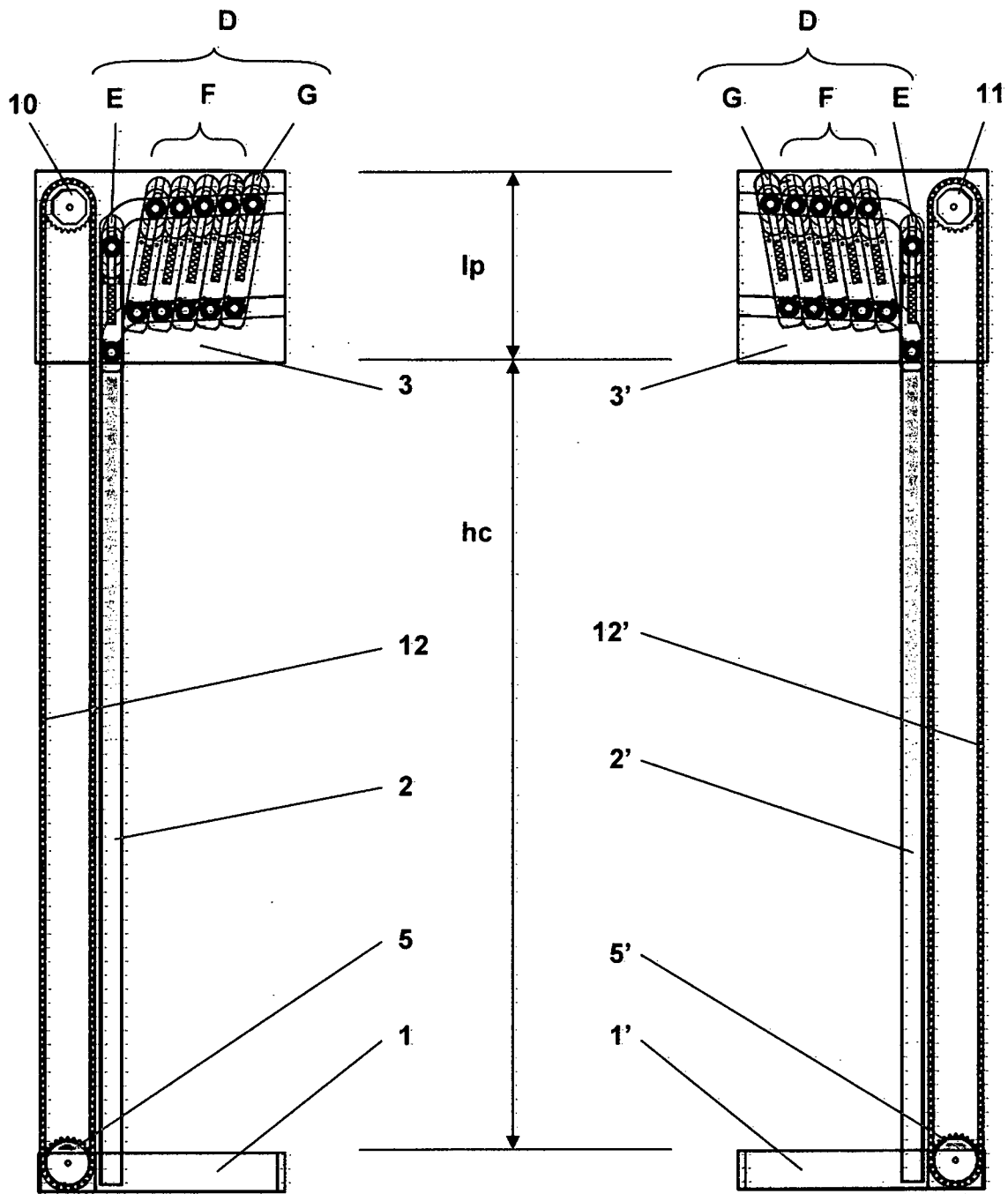

Fig.2a

Fig.2b

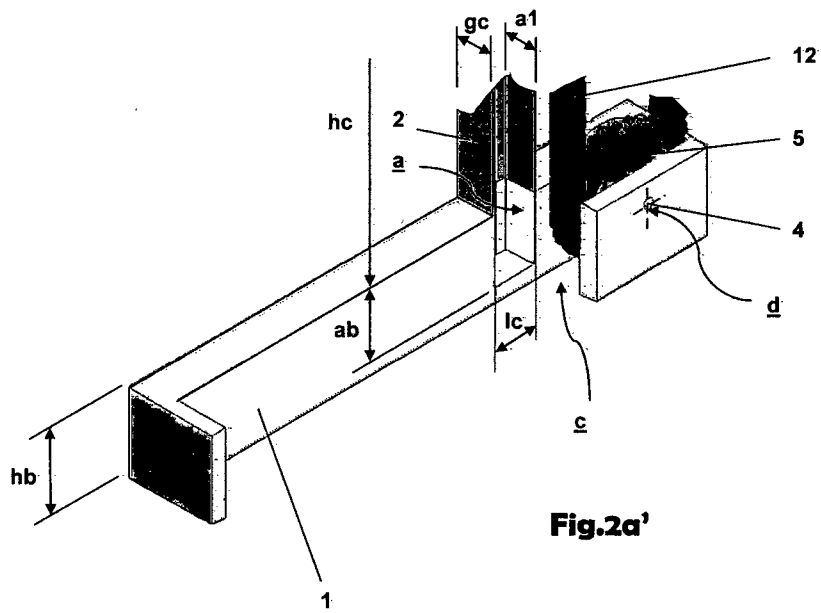
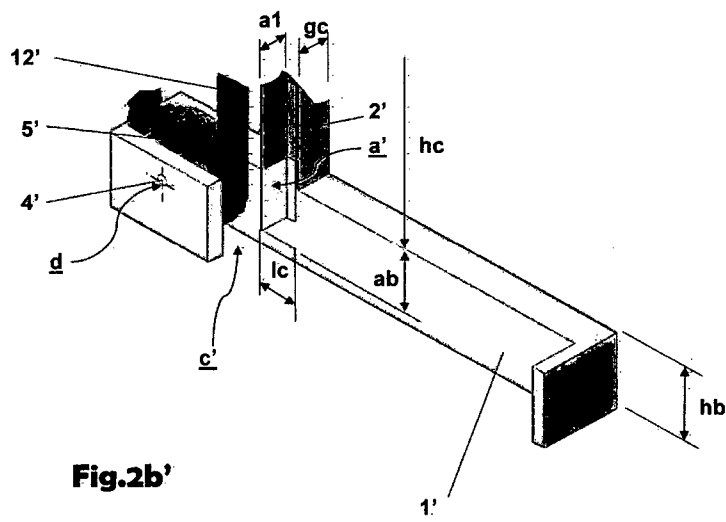

Fig.2a'



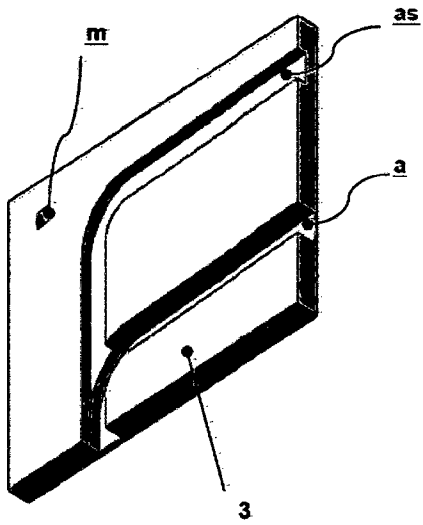

Fig.3.3

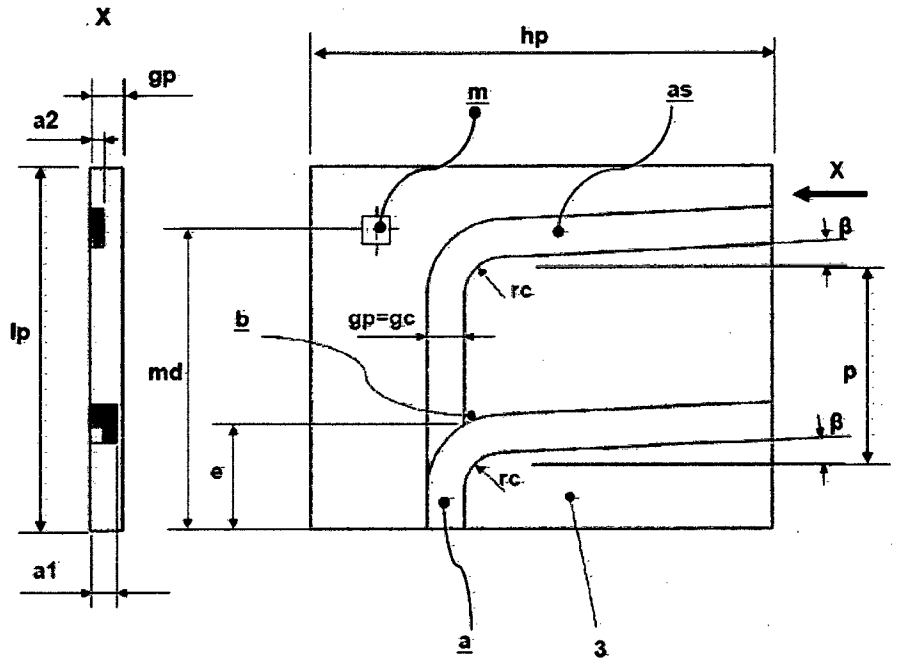

Fig.3.2

Fig.3.1

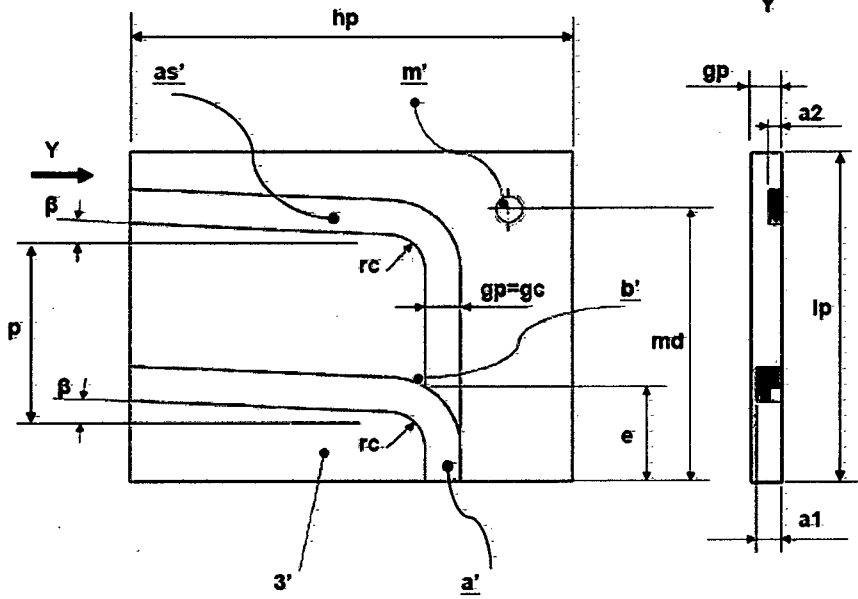

Fig.4.1

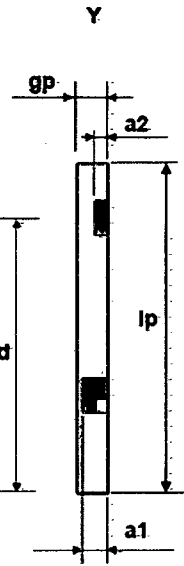

Fig.4.2

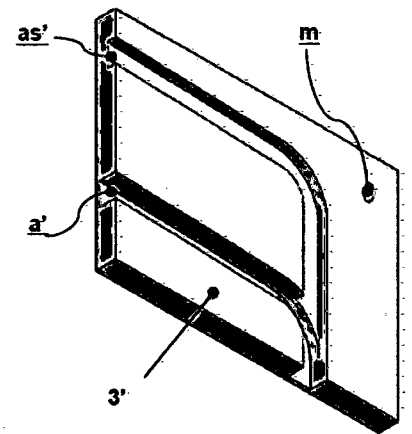

Fig.4.3

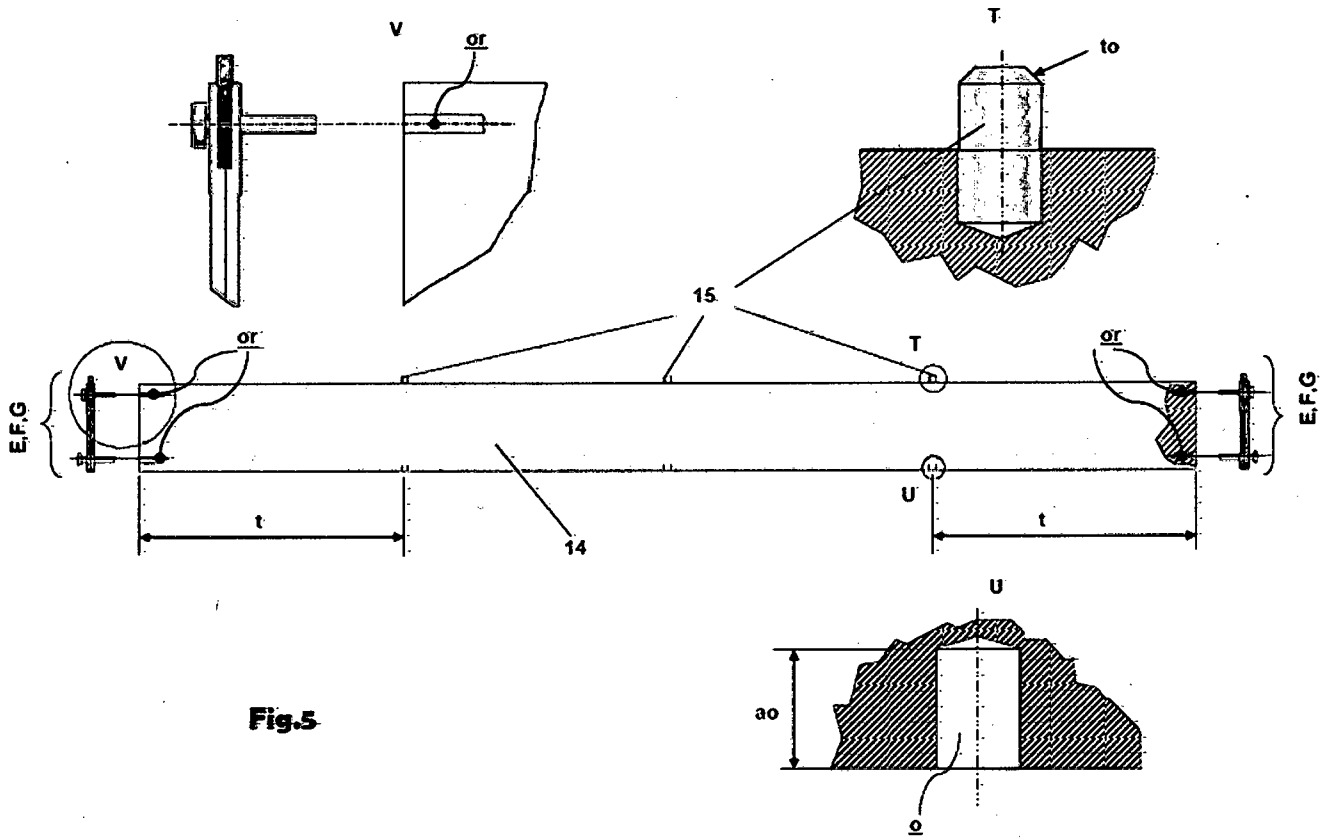

Fig.5

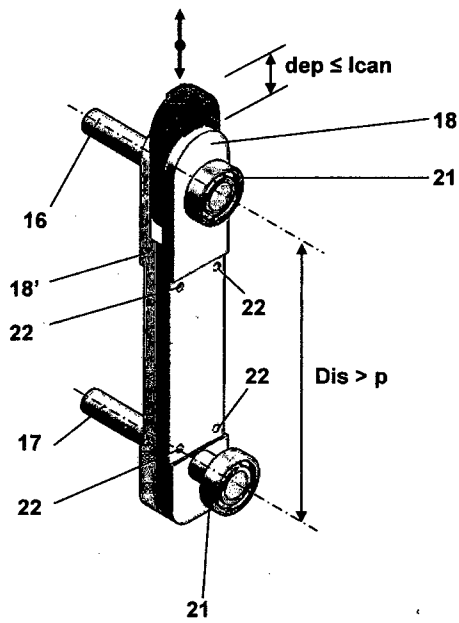

Fig.6

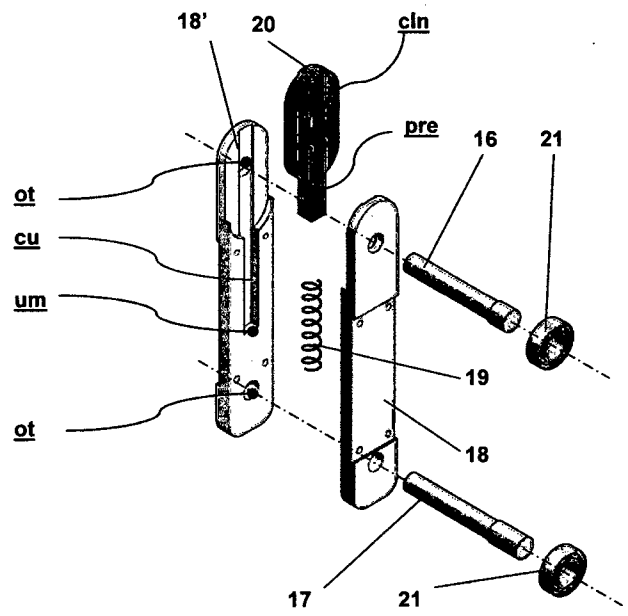

Fig.6'

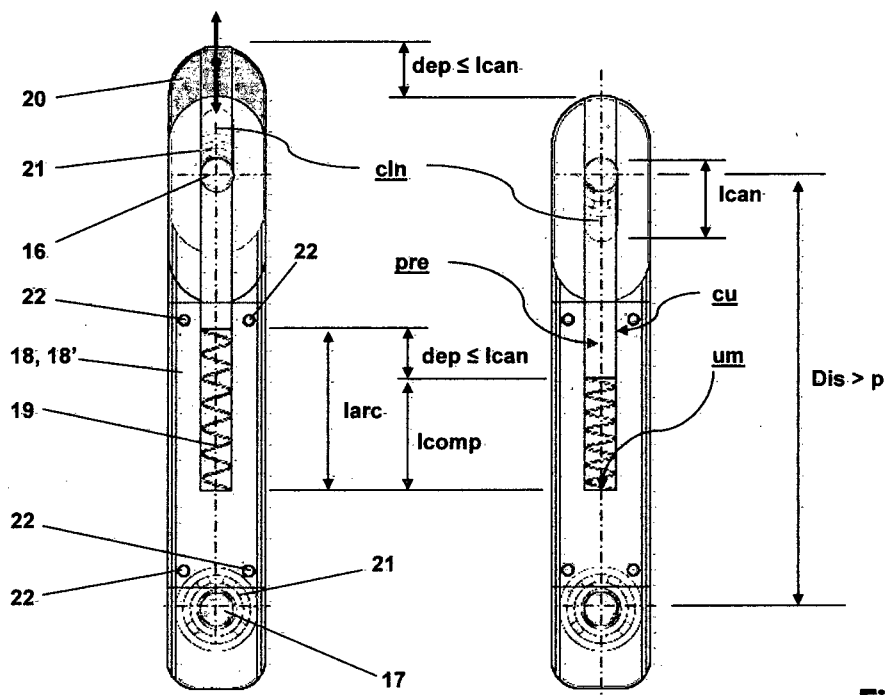

Fig.6''

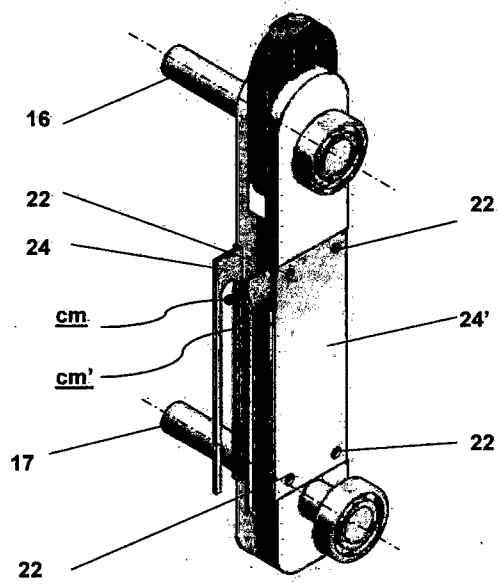

Fig.7

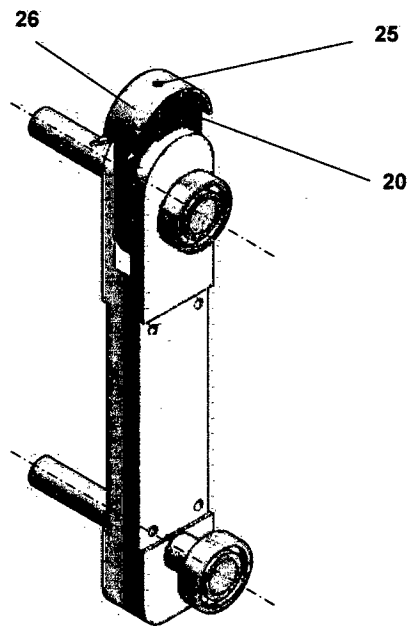

Fig.8

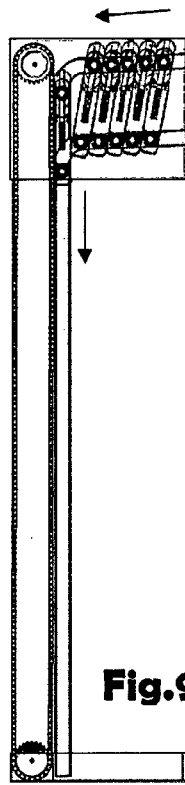

Fig.9.1

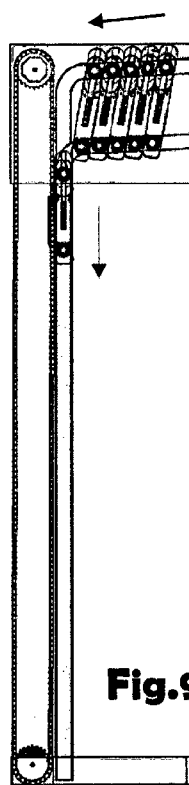

Fig.9.2

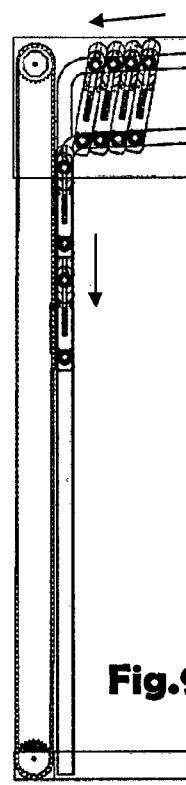

Fig.9.3

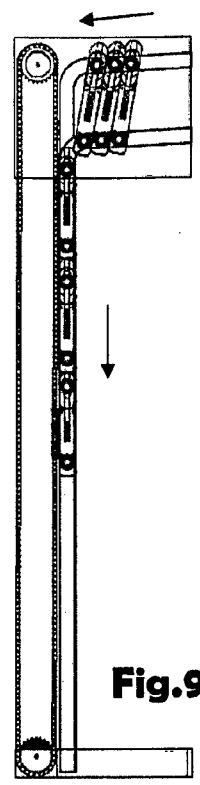

Fig.9.4

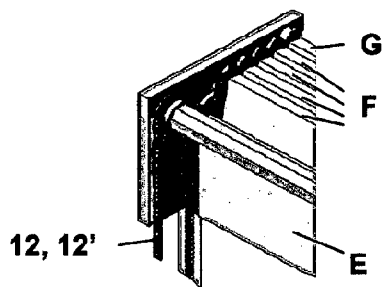

Fig.9.1'

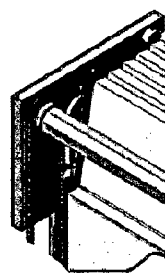

Fig.9.2

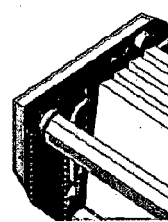

Fig.9.3'

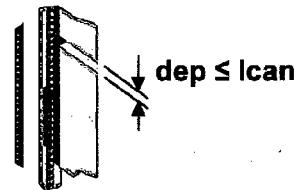

Fig.9.3'

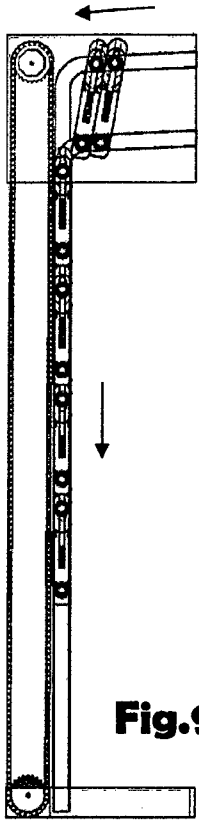

Fig.9.5

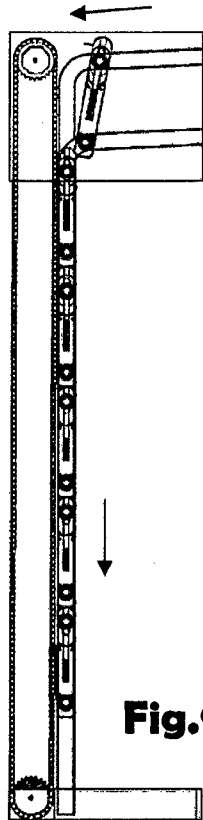

Fig.9.6

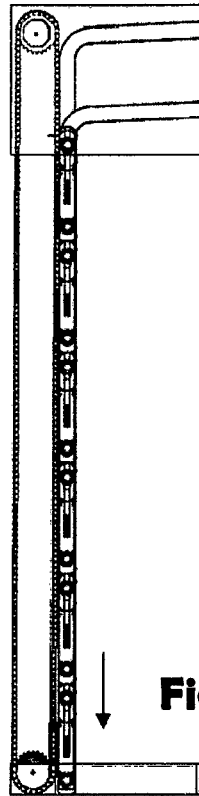

Fig.9.7

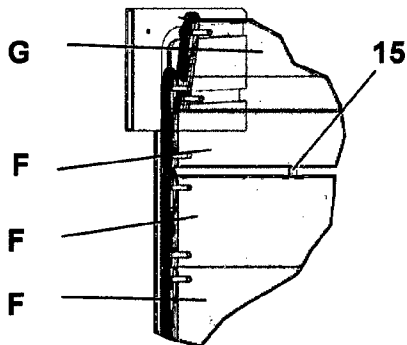

Fig.9.6'

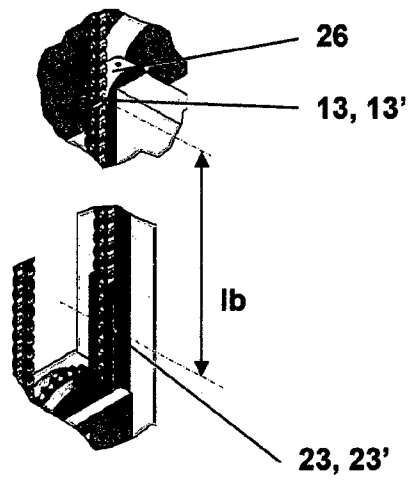

Fig.9.7'

Fig.9.7''

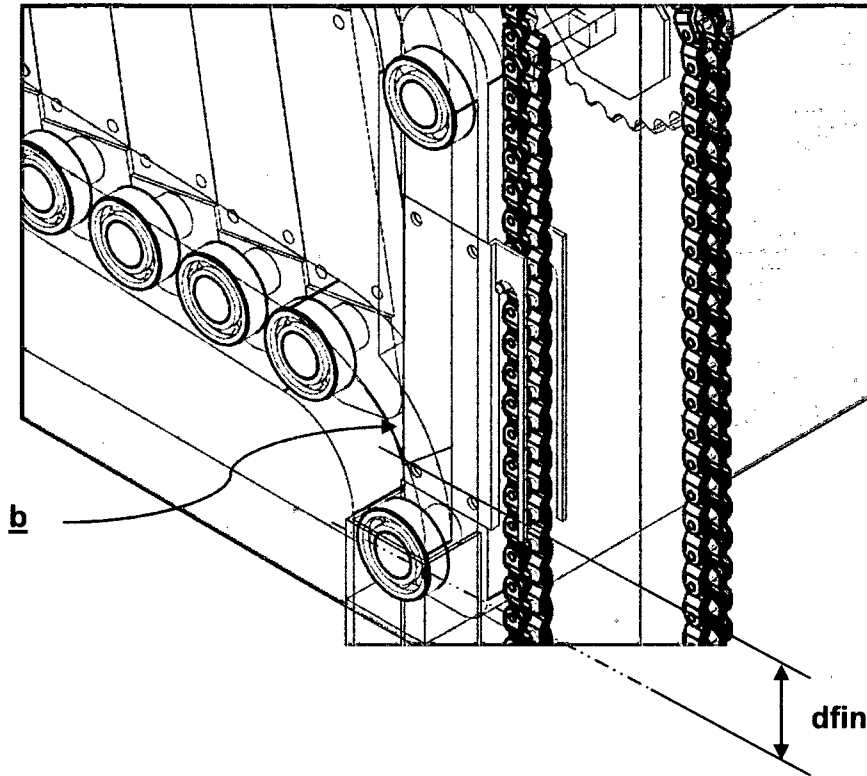

Fig.10

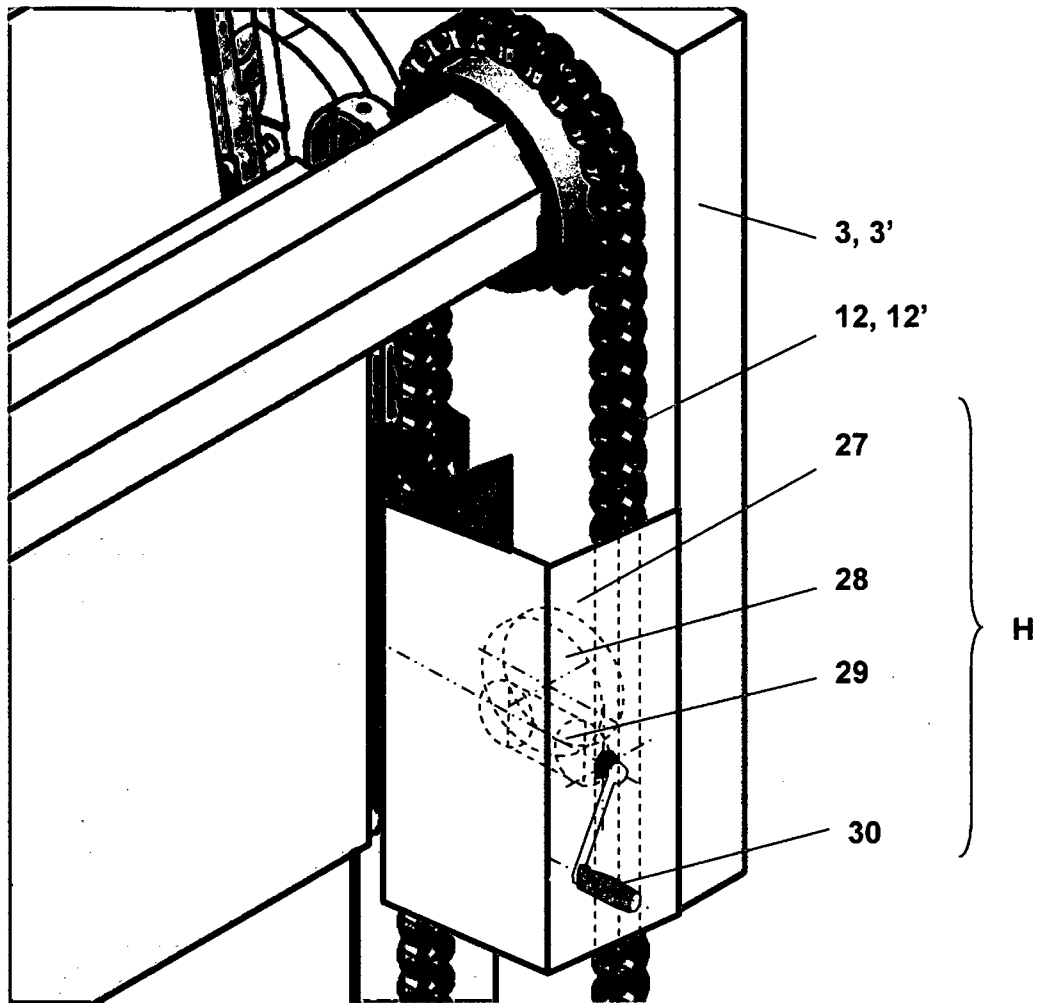

Fig.11

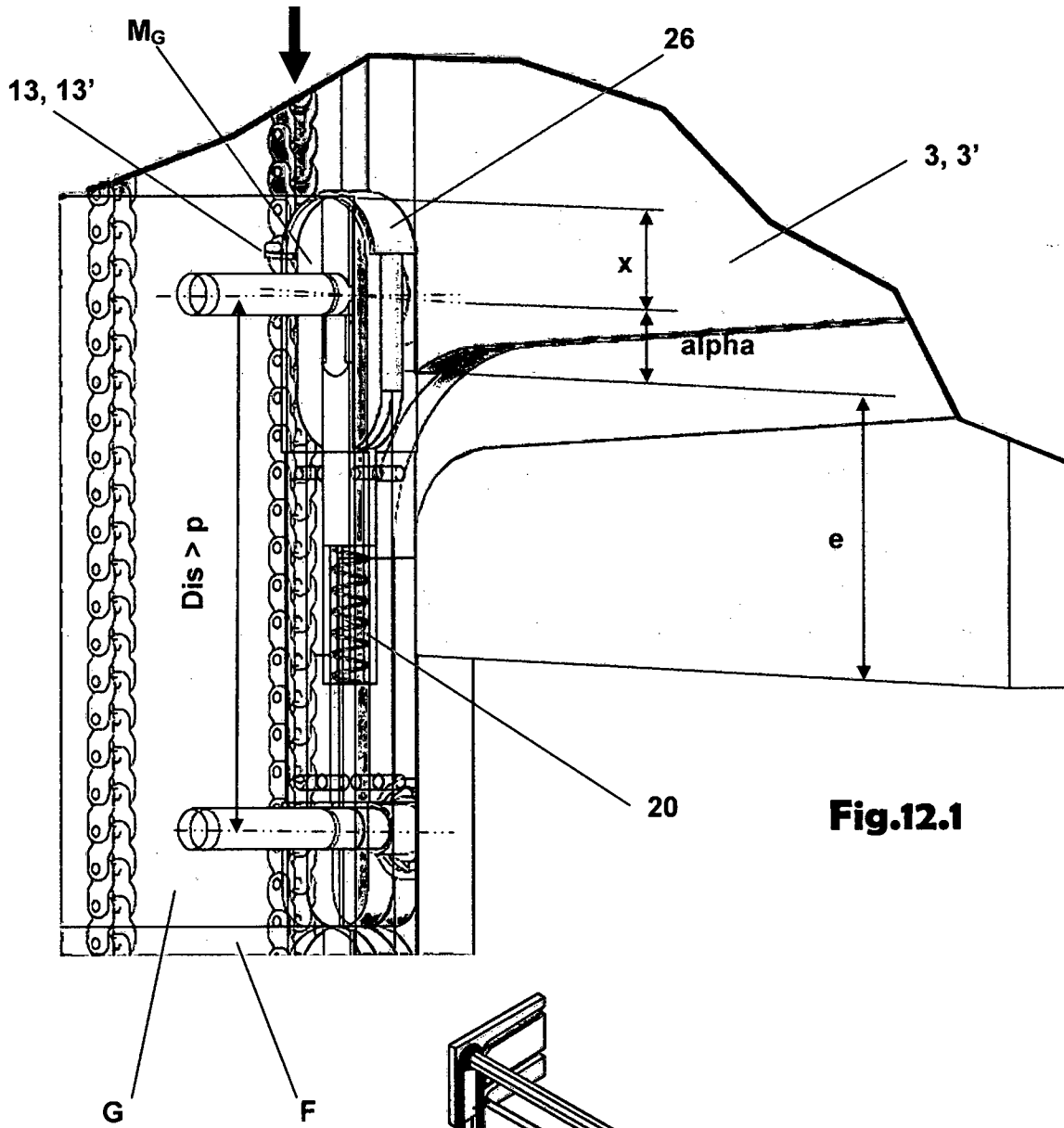

Fig.12.2

