



US 20080237395A1

(19) **United States**

(12) **Patent Application Publication**
Tanabe et al.

(10) **Pub. No.: US 2008/0237395 A1**

(43) **Pub. Date: Oct. 2, 2008**

(54) **BVI NOISE REDUCTION METHOD AND APPARATUS FOR HELICOPTER**

Publication Classification

(76) Inventors: **Yasutada Tanabe**, Tokyo (JP);
Takeshi Akasaka, Tokyo (JP);
Shigeru Saito, Tokyo (JP); **Noboru Kobiki**, Tokyo (JP)

(51) **Int. Cl.**
B64C 27/43 (2006.01)
B64C 23/00 (2006.01)
B64C 11/20 (2006.01)
(52) **U.S. Cl.** **244/1 N; 416/24**
(57) **ABSTRACT**

Correspondence Address:
GREENBERG TRAURIG LLP (LA)
2450 COLORADO AVENUE, SUITE 400E,
INTELLECTUAL PROPERTY DEPARTMENT
SANTA MONICA, CA 90404 (US)

The present method is characterized by providing the rotor blade with a tab 3, which can advance and retreat with respect to rear of rotating direction of the rotor blade between a position where the tab protrudes from a trailing edge of the rotor blade and a position where the tab does not, and providing an actuator 4, which advances and retreats the tab 3, and operating the actuator 4 so that the tab advances and retreats in response to rotating timing of the rotor blade 2, when reducing the BVI noise of the rotor blade of a helicopter. Thus, the BVI noise of a helicopter can be reduced effectively.

(21) Appl. No.: **10/570,082**

(22) Filed: **Feb. 28, 2006**

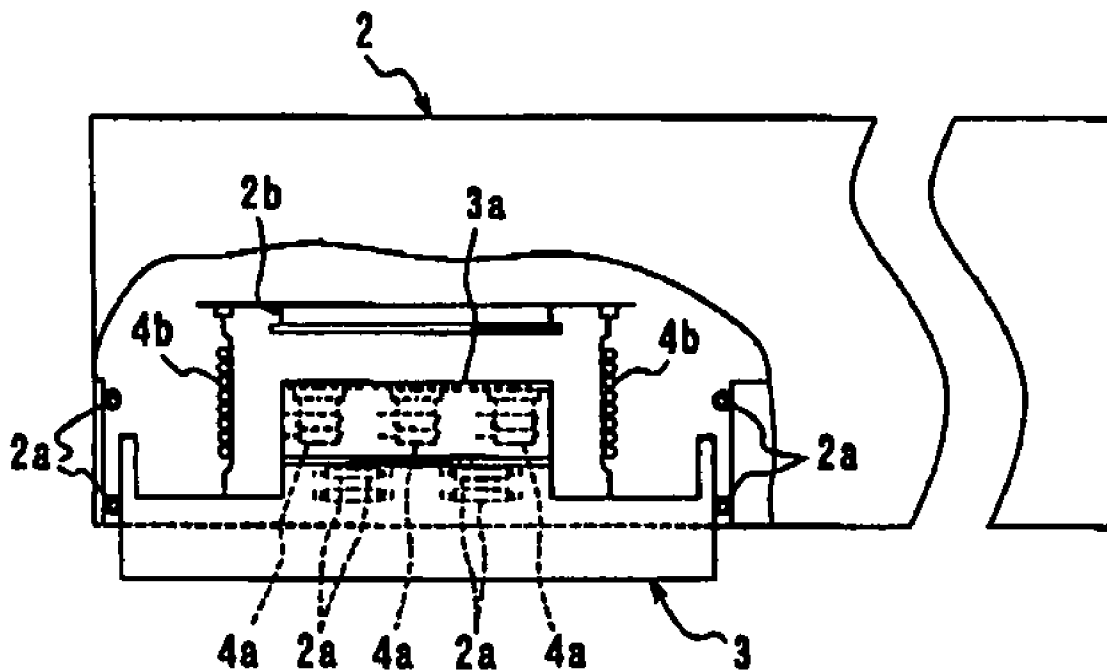

FIG. 1

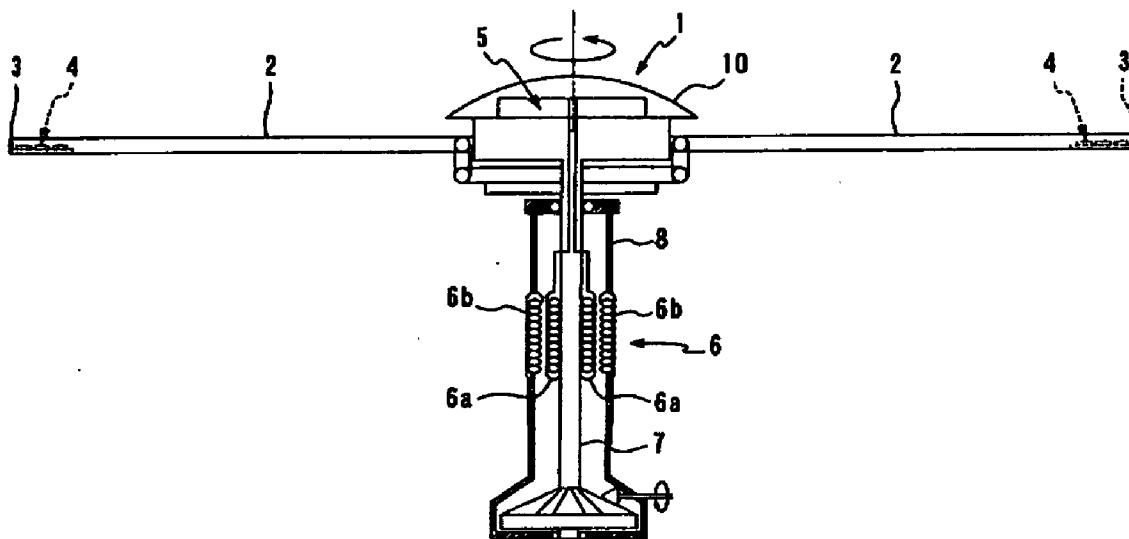

FIG. 2a

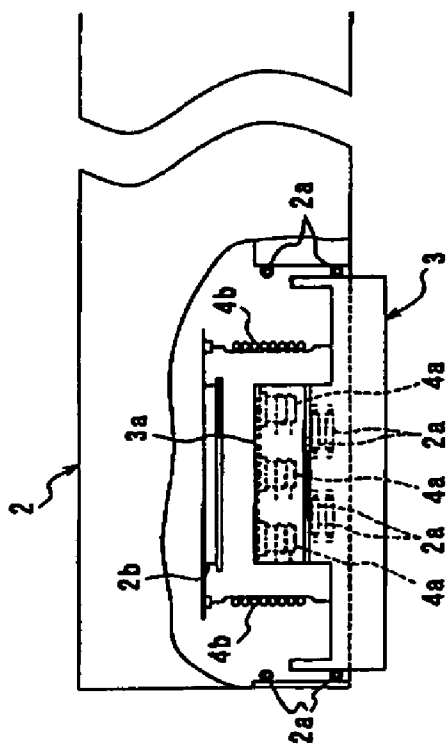

FIG. 2b

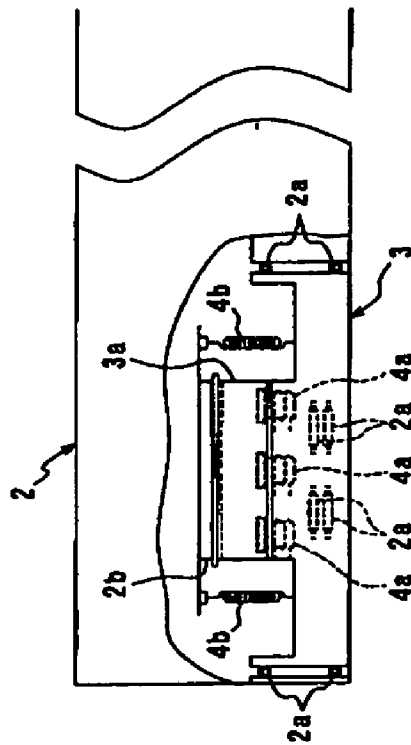

FIG. 3a

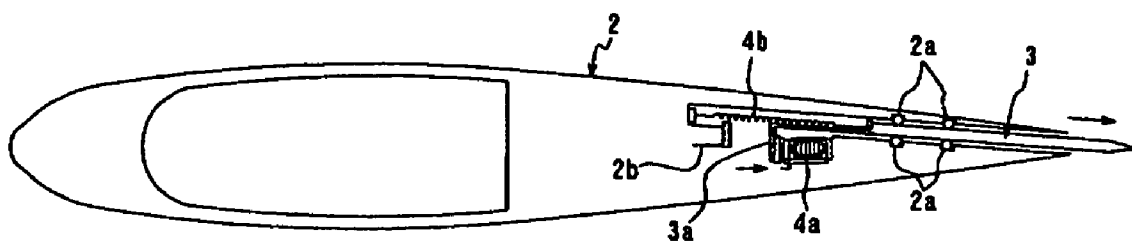

FIG. 3b

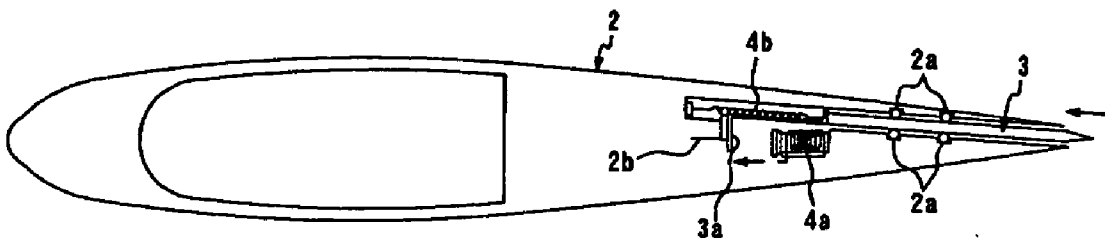
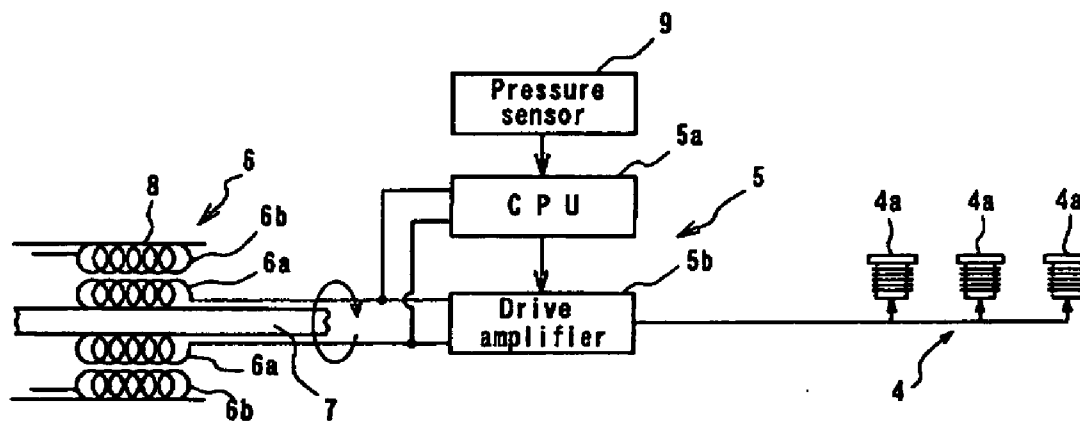

FIG. 4



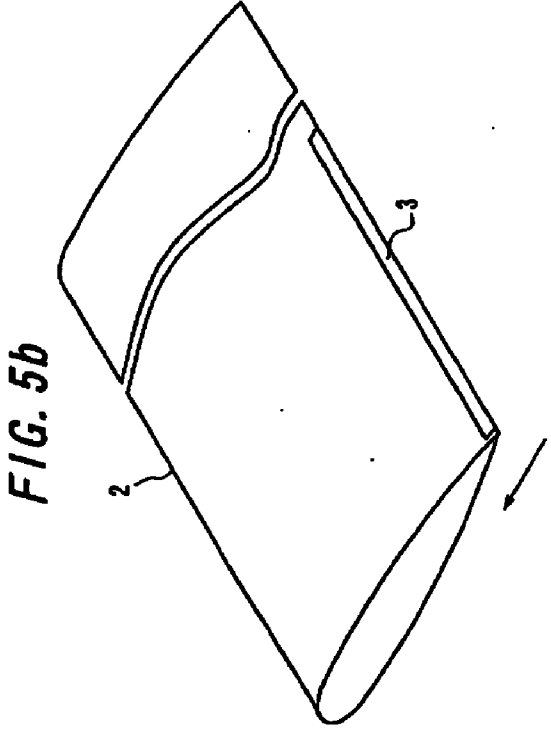
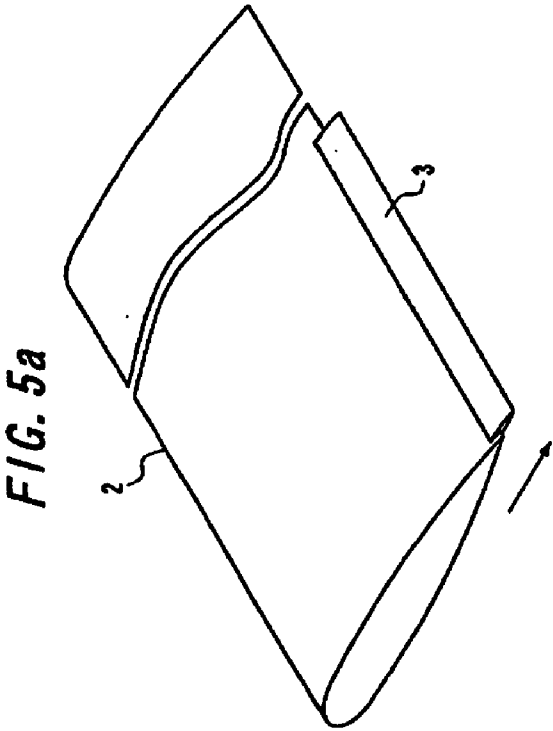

FIG. 6a

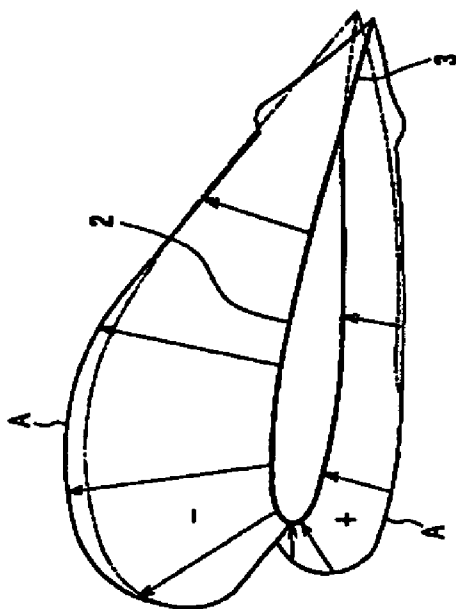

FIG. 6b

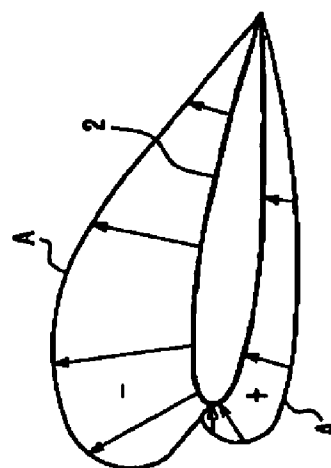

FIG. 7a

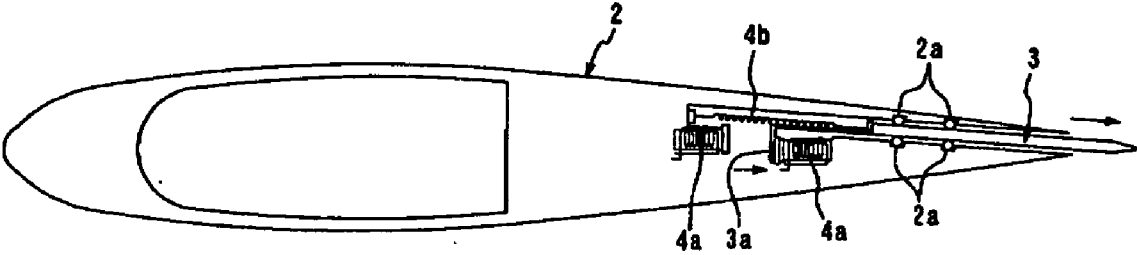

FIG. 7b

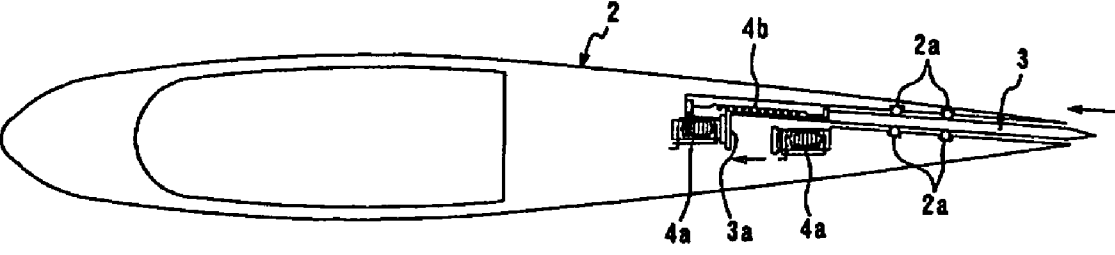

FIG. 8a

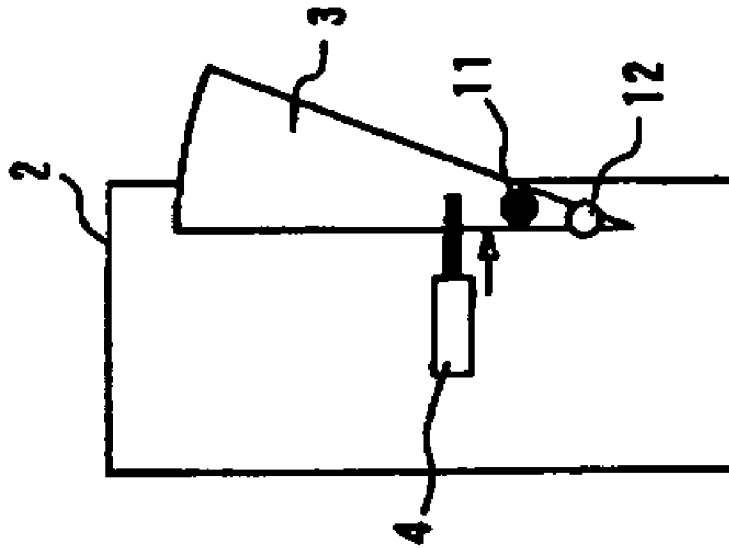

FIG. 8b

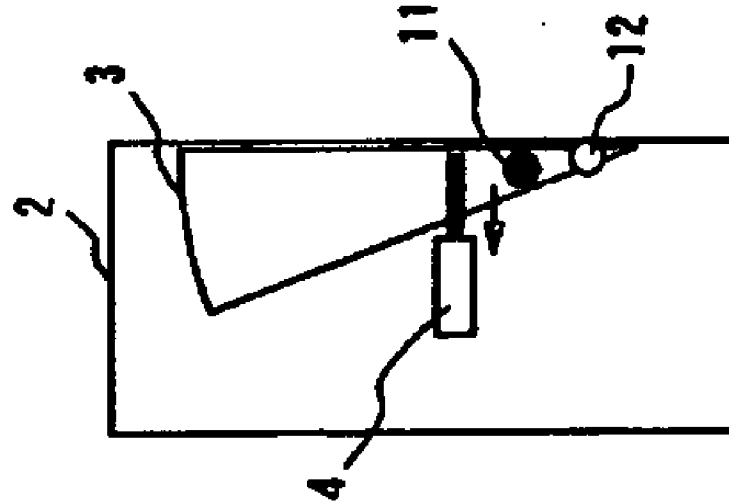

FIG. 9

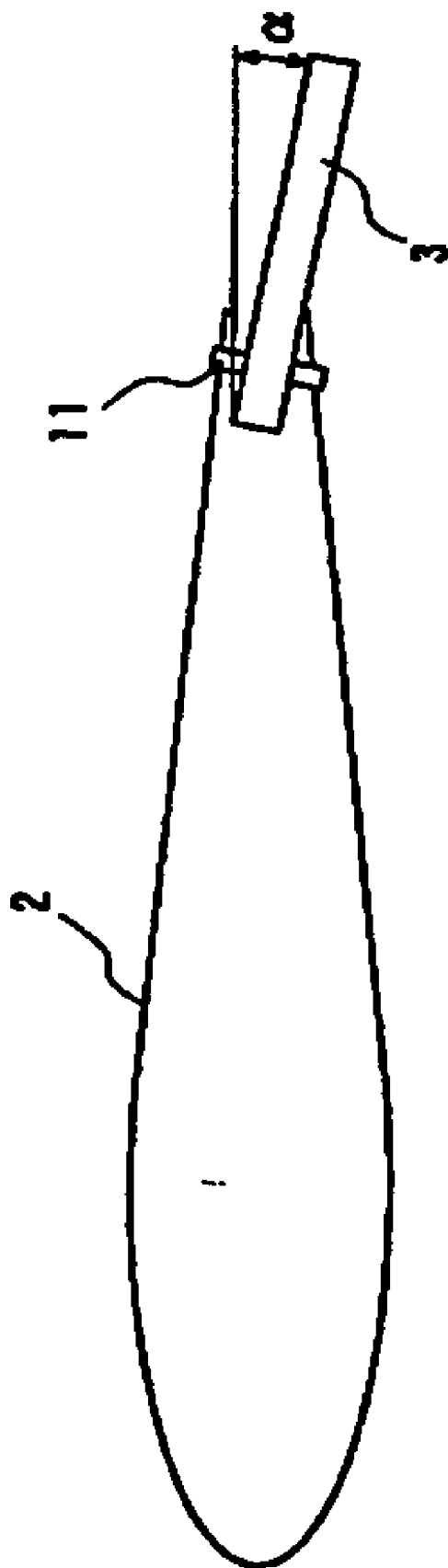

FIG. 10

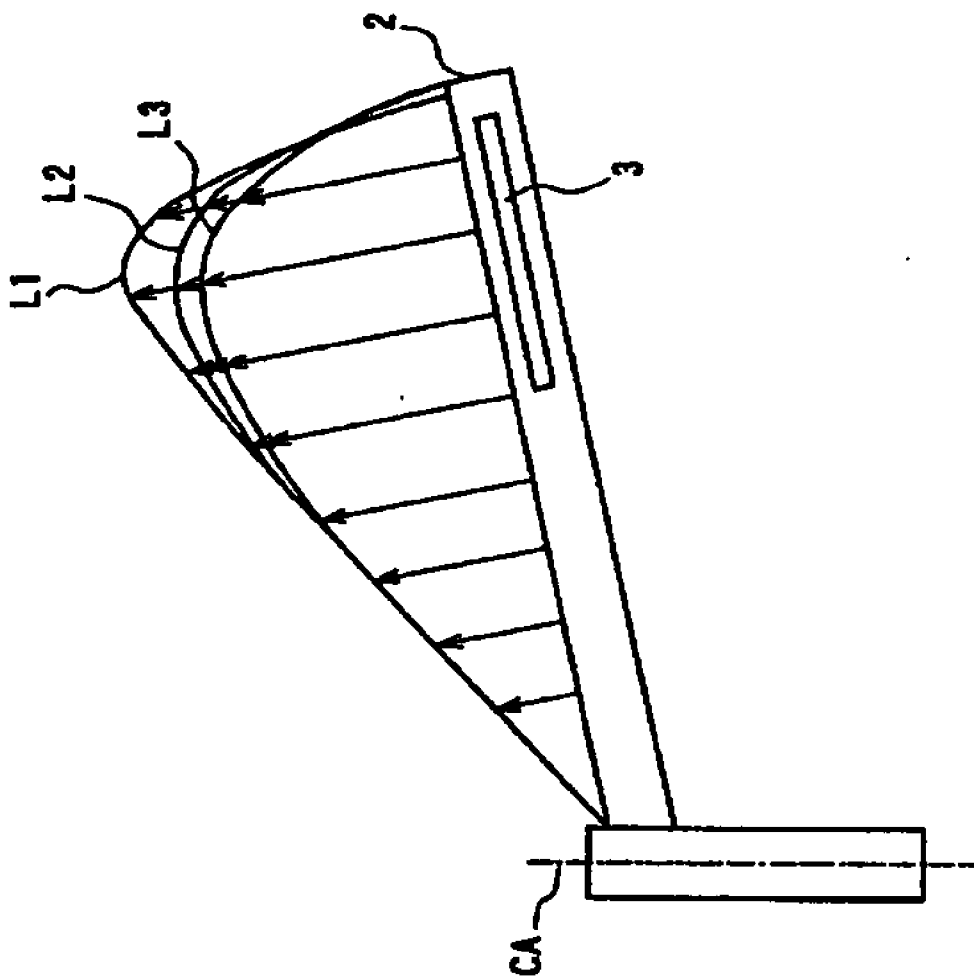

FIG. 11a

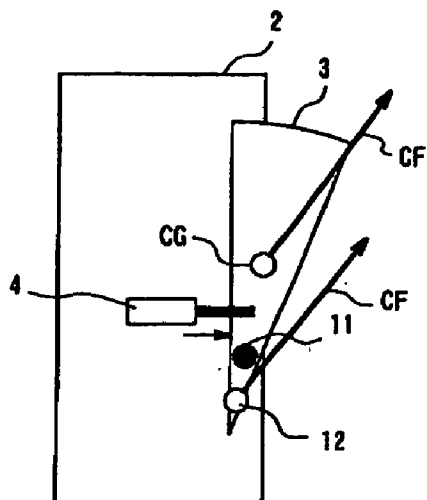

FIG. 11b

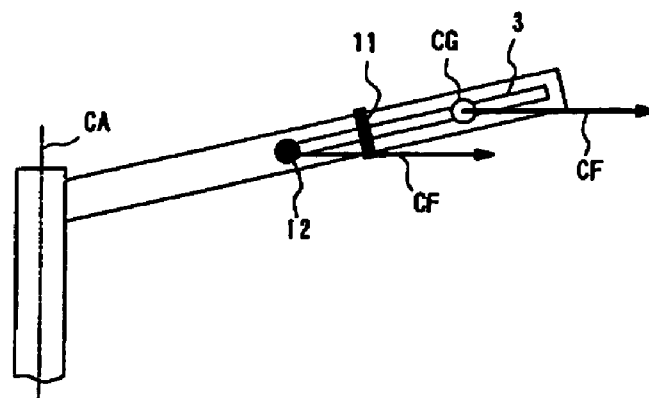

FIG. 12a

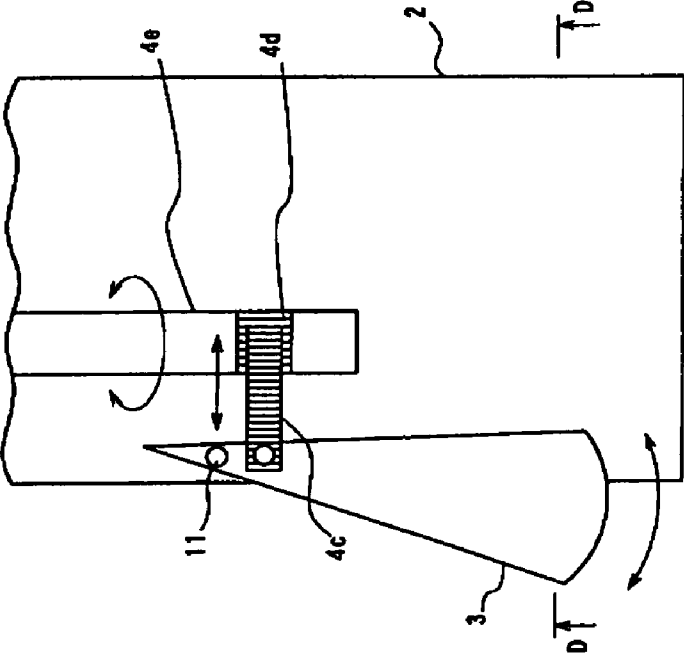

FIG. 12b

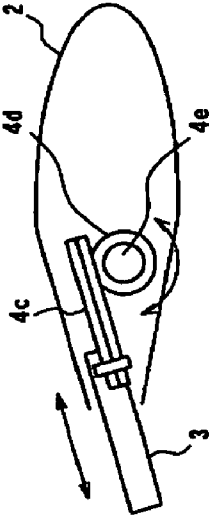

FIG. 13

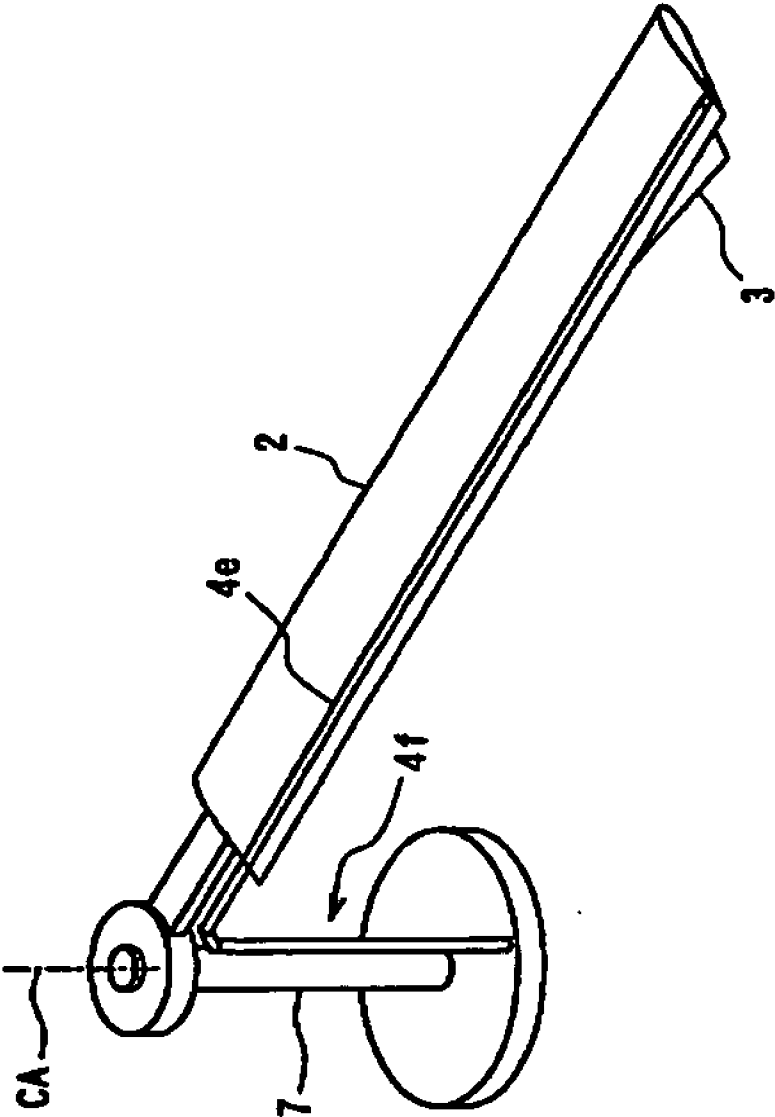

FIG. 14

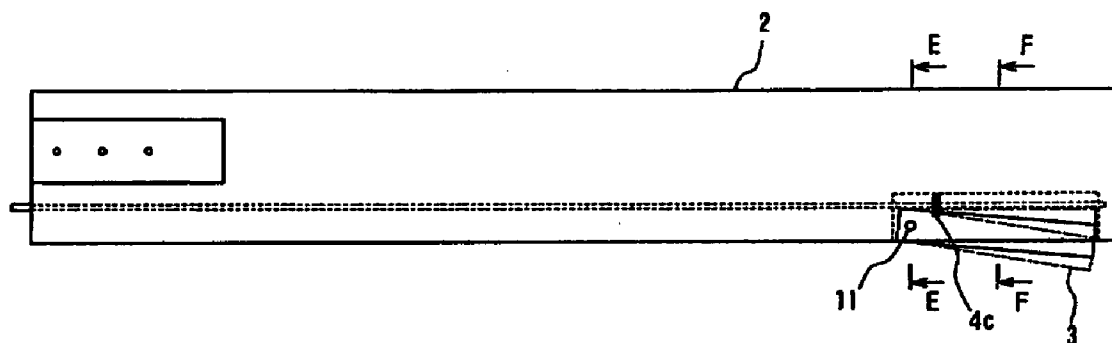

FIG. 15

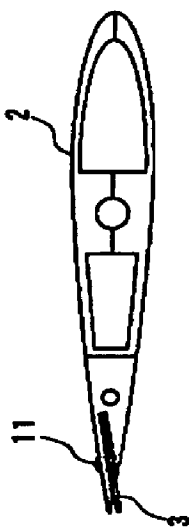

FIG. 16a

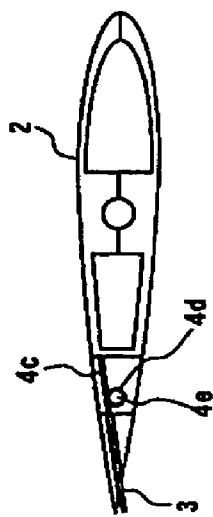

FIG. 16b

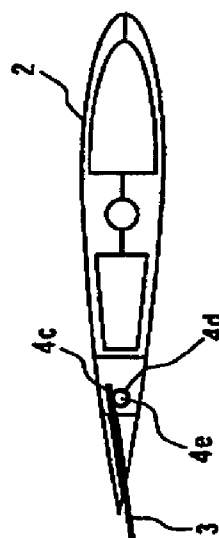

FIG. 17

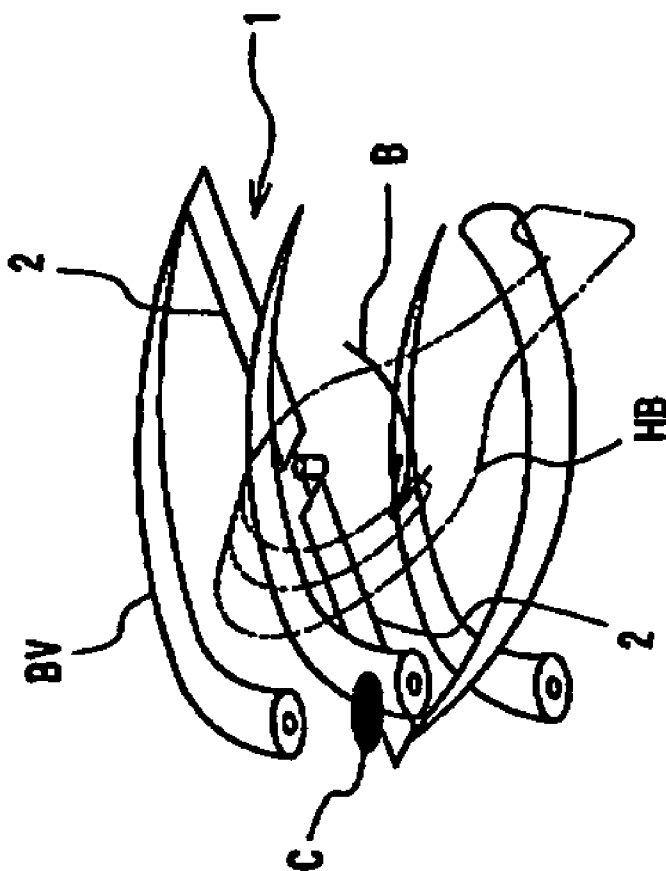

FIG. 18a

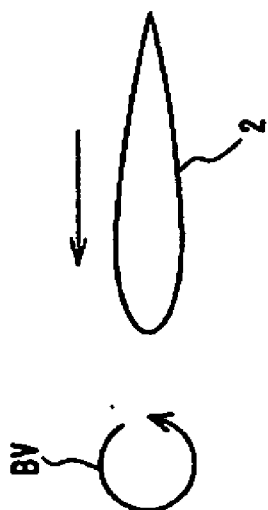

FIG. 18b

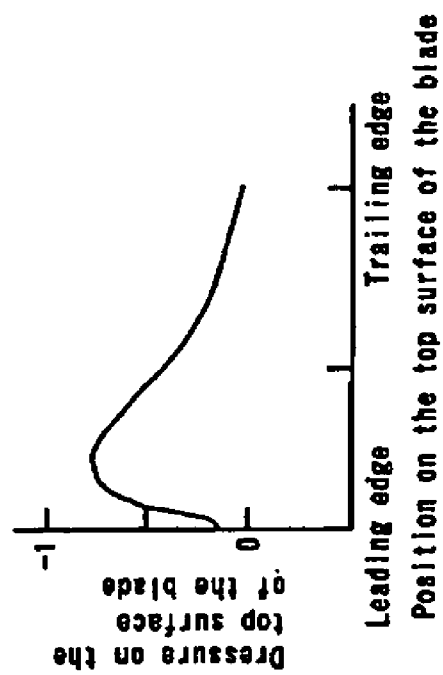

FIG. 19a

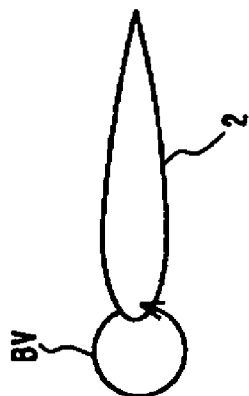
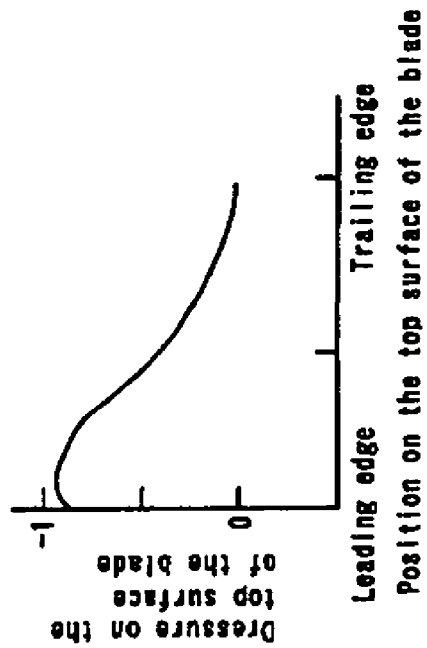

FIG. 19b



BVI NOISE REDUCTION METHOD AND APPARATUS FOR HELICOPTER

FIELD OF THE INVENTION

[0001] The present invention relates to a method and an apparatus that can be used for reducing BVI (Blade Vortex Interaction) noise generated by rotor blades of a helicopter.

BACKGROUND ART

[0002] In recent years reduction of a noise of a helicopter is expected, and a method described in Japanese Patent Laid-Open No. 10-271852 bulletin, for example, is known as a measure for the noise reduction. In the technology as described in this bulletin, in order to reduce a noise by decreasing the rotational velocity of a rotor, the aerodynamic characteristic of the rotor blades is improved by providing the trailing edge of the rotor blade with a small flap, whose tilt angle to the rotor blade is controlled precisely by the twist actuator in the rotor blade using a piezoelectric element.

[0003] However, the measure using a flap is in practice not so easy, since great control force and high response are required for changing the angle of the flap in the rapidly rotating rotor blade.

[0004] Incidentally, none of other noises of a helicopter is as loud as the BVI noise. Reduction of the BVI noise is thus very effective for reducing the whole noise of a helicopter.

[0005] The BVI noise is explained below; When lift force is generated by rotations of the rotor system **1** shown by arrow B in FIG. **17** and the helicopter body HB ascends and moves forward, the blade tip vortex BV is generated from the tip of the rotor blade **2**. After this blade tip vortex BV draws away from the tip of the rotor blade **2**, it drifts downwards and backwards with the rotor slipstream while it proceeds to the center of rotation of the rotor system **1**. When the rotor blade **2** following the preceding rotor blade **2** enters into the rotor slipstream containing the blade tip vortex BV generated from the preceding rotor blade **2** illustrated as area C, while pressure at the leading edge of the blade is not very high before entry as in FIG. **18(a)** showing positional relationship between the blade tip vortex BV and the rotor blade **2**, and FIG. **18(b)** showing pressure distribution on the top surface of the blade, pressure at the leading edge of the blade at the time of entry goes extremely low, or extremely high according to the timing of entry as in FIG. **19(a)** showing positional relationship between the blade tip vortex BV and the rotor blade **2**, and FIG. **19(b)** showing pressure distribution on the top surface of the blade, bringing about local fluctuation of pressure distribution on the top surface of the rotor blade **2**, which influences the attack angle of the rotor blade **2**. This fluctuation of pressure distribution causes an impulsive noise which stands out among other noises. This is the noise called slap noise, or BVI (Blade Vortex Interaction) noise since it is generated by interaction between the blade tip vortex and the rotor blade.

[0006] Accordingly, in efforts to reduce the BVI noise in order to reduce the whole noise of a helicopter, the inventors of the present invention reached a point where if the trailing edge section of the rotor blade is provided with a tab, which is put in and out of the trailing edge of the rotor blade, lift force of the rotor blade can be locally changed, and this change moderates interaction between the blade tip vortex and the rotor blade, by strengthening a downdraft current over the entire rotor blade and sweeping downward the blade tip vor-

tex and by locally changing height of the rotor blade, and at the same time an actuator can be configured easily and also high response can be achieved readily since not so big control force is required for advance or retreat of the tab.

DESCRIPTION OF THE INVENTION

[0007] The present invention provides a BVI noise reduction method and apparatus that has solved a prior-art problem in view of the information described above and the BVI noise reduction method for a helicopter according to the present invention is characterized by, when reducing the BVI noise of the rotor blade of a helicopter, providing the rotor blade with a tab which can advance or retreat with respect to rear of rotating direction between a position where the tab protrudes from a trailing edge of the rotor blade and a position where the tab does not, and also by providing the rotor system including the rotor blade which rotates with respect to a body of the helicopter with an actuator which advances and retreats the tab and operating the actuator so that the tab can advance and retreat in response to the rotating timing of the rotor blade.

[0008] In this way, the BVI noise can be reduced by locally changing lift force of the rotor blade and with this change moderating interaction between the blade tip vortex and the rotor blade by means of strengthening a downdraft current over the entire rotor blade and sweeping downward the blade tip vortex and also locally changing height of the rotor blade, because it is possible to advance and retreat the tab provided in the rotor blade, which can advance and retreat with respect to rear of rotating direction between a position where the tab protrudes from a trailing edge of the rotor blade and a position where the tab does not, in response to rotating timing of the rotor blade, by operating the actuator in the rotor system including the rotor blade, and thus increasing lift force by advancing the tab to the position where the tab protrudes from the trailing edge of the rotor blade, and also decreasing lift force to the former condition by retreating the tab to the position where the tab does not protrude from the trailing edge of the rotor blade.

[0009] Moreover, since not so big control force is required for such advance and retreat of the tab with respect to rear of rotating direction from the trailing edge of the rotor blade, the actuator which activates the tab can be configured to be small enough to be set in the rotor system, and at the same time high response of the tab can be achieved easily.

[0010] In addition, in an embodiment of the method according to the present invention, a drive shaft included in the rotor system which rotates the rotor blade may be provided with a coil of a generator so that electricity generated from the generator by rotating the drive shaft can be supplied from the coil to the actuator. Thus, it may become unnecessary to provide a mast supporting the drive shaft of the rotor system with a collector ring for power supply to the actuator, and the rotor system may be equipped with an independent noise reduction device. Thus, potential cause for the noise reduction apparatus to break down may be reduced, its reliability increased, and its maintenance check simplified.

[0011] Also, in another embodiment of the method according to the present invention, the actuator may be operated to make the tab advance and retreat so that the rotor blade following the preceding rotor blade avoids the blade tip vortex generated from the preceding rotor blade, based on the rotating timing with which the rotor blade following the preceding rotor blade approaches the blade tip vortex generated from the preceding rotor blade and which is detected from a

phase of the electric power generated from the generator. Thus, by utilizing the generator for power supply to the actuator, lift force of the rotor blade may be changed locally and interaction between the blade tip vortex and the rotor blade may be moderated inexpensively and easily.

[0012] Furthermore, in another embodiment of the method according to the present invention, excrescence quantity of the tab may be controlled based on an output signal from a pressure sensor provided in a leading edge of the rotor blade. Thus, because it may become possible to detect whether the blade tip vortex can actually be avoided or not by the output signal from the pressure sensor, interaction between the blade tip vortex and the rotor blade may be moderated more reliably.

[0013] And, in another embodiment of the method according to the present invention, the rotor blade may be provided with the tab so that the tab can swing around a specified axis between a position where the tab protrudes from the trailing edge of the rotor blade and a position where the tab does not and can advance and retreat with respect to rear of rotating direction of the rotor blade. Thus, it may become possible to make a support structure of the tab a simple swinging type and by doing so restrain weight of the rotor blade and increase of the cost.

[0014] Now, a BVI noise reduction apparatus for a helicopter according to the present invention is an apparatus to reduce the BVI noise of the rotor blade of a helicopter characterized by including a tab provided in the rotor blade, which can advance and retreat with respect to rear of rotating direction of the rotor blade between a position where the tab protrudes from a trailing edge of the rotor blade and a position where the tab does not, and an actuator which is provided in a rotor system which includes the rotor blade and rotates with respect to a body of the helicopter and which advances and retreats the tab, and a control device which is provided in the rotor system and operates the actuator so that the tab advances and retreats in response to rotating timing of the rotor blade.

[0015] In the apparatus according to the present invention, the actuator provided in the rotor system including the rotor blade, advances and retreats the tab provided in the rotor blade, with respect to rear of rotating direction of the rotor blade, between a position where the tab protrudes from the trailing edge of the rotor blade and a position where the tab does not, and the control device, which is also provided in the rotor system, operates the actuator so that the tab advances and retreats in response to rotating timing of the rotor blade.

[0016] Thus, in the apparatus according to the present invention, lift force of the rotor blade can be increased by the tab advancing to a position where the tab protrudes from a trailing edge of the rotor blade and can be decreased to the former condition by the tab retreating to a position where the tab does not protrude from the trailing edge of the rotor blade. Therefore, when the rotor blade reaches the position of the blade tip vortex, lift force of the rotor blade is changed locally, and at the same time pressure in the vicinity of a leading edge of the rotor blade is changed instantly, moderating interaction between the blade tip vortex and the rotor blade, and thus successfully reducing the BVI noise.

[0017] In addition, because not so big control force is required for such advance and retreat of the tab with respect to rear of rotating direction from a trailing edge of the rotor blade, the actuator, which activates the tab, can be configured easily to be small enough to be set in the rotor system, readily making high response of the tab possible.

[0018] Moreover, an embodiment of the apparatus according to the present invention may include a generator which has a coil provided in a drive shaft which is included in the

rotor system and rotates the rotor blade, and which supplies electric power generated by the rotating drive shaft, from the coil to the actuator. Such configuration enables to equip the rotor system with an independent noise reduction device and enables to make it unnecessary to provide the mast supporting the drive shaft of the rotor system with a collector ring for supplying electricity to the actuator, and thus potential cause for the noise reduction apparatus to break down may be reduced, its reliability increased, and its maintenance check simplified.

[0019] In addition, in another embodiment of the apparatus according to the present invention, the actuator may advance and retreat the tab with an electromagnet for pushing out the tab and a spring for pulling back the tab. Such configuration enables to secure maneuverability of a typical helicopter, for even if electric power supply to the actuator or the electromagnet for pushing out the tab is stopped, the spring for pulling back the tab pulls back the tab to a position where the tab does not protrude from a trailing edge of the rotor blade. Furthermore, in another embodiment of the apparatus according to the present invention, the tab may be positioned at a leading edge of the rotor blade. With such configuration even a slightest advance or retreat of the tab can make the rotor blade go up and down, and a lighter and smaller actuator can be used, since the tab is positioned at the highest part of the circumferential direction velocity of the rotor blade.

[0020] Further, in another embodiment of the apparatus according to the present invention, the tab may be provided in the rotor blade so that it will swing around a specified axis between a position where the tab protrudes from a trailing edge of the rotor blade and a position where the tab does not and is able to advance and retreat with respect to rear of rotating direction of the rotor blade. Such configuration enables to make the support structure of the tab a simple swinging type and by doing so restrain weight of the rotor blade and increase of the cost.

[0021] In another embodiment of the apparatus according to the present invention, the tab may be fan-shaped, and may be positioned at the rotor blade in such direction that the tab becomes wider as the tab gets closer to a tip of the rotor blade, and also a narrower part in the vicinity of the pivot part of the fan-shaped tab may be secured to the rotor blade with an axis. With such configuration the rotating direction velocity, in other words circumferential velocity, becomes higher as it gets closer to the tip of the rotor blade, and the tab can be exposed to air current at higher rotating direction velocity to obtain more air force, and eventually the BVI noise can be reduced effectively.

[0022] In another embodiment of the apparatus according to the present invention, the actuator may add driving force for the tab to advance and retreat at the vicinity of the pivot part. Such configuration, since it adds driving force for the tab to advance and retreat at the vicinity of the pivot part of the tab, enables to make operation stroke of the actuator small and make the actuator more compact, and also enables to reduce load on the actuator, since the actuator is further away from the tip of the rotor blade and can be operated at a position where centrifugal force is smaller.

[0023] Further, in another embodiment of the apparatus according to the present invention, the tab may be provided with a counterweight at the part where the tab is narrower than at the pivot part. Such configuration enables to moderate or offset an element of centrifugal force on the tab around the axis supporting the tab resulting from the rotating rotor blade, by an element of centrifugal force on the counterweight around the axis supporting the tab, and enables to reduce

stiffness of the tab support structure and of the movable part of the actuator, and thus enables to reduce load on the actuator.

[0024] Furthermore, in another embodiment of the apparatus according to the present invention, the tab may be pivoted to the rotor blade so that the tab can swing around the supporting axis, which slants such way that the supporting axis gets closer to the rear of the rotor blade as the supporting axis gets more upward or downward in the up-and-down direction of the rotor blade. Such configuration enables to give the tab a projecting angle other than 0 degree off the horizontal direction of the rotor blade, and more air force can be obtained with the camber effect, and consequently can reduce the BVI noise effectively.

[0025] And, in an embodiment of the apparatus according to the present invention, the actuator may have a rack coupled with the tab; a transmission shaft which includes a pinion engaged into the rack, and which extends from a base to a tip of the rotor blade and is supported by the rotor blade pivotably; and a linkage which is provided in the rotor system and functions as the control device, and in conjunction with, for example, a swash plate, rotates the transmission shaft so that the tab advances and retreats in response to rotating timing of the rotor blade. Such configuration enables to make it unnecessary to have an electrical system in the control device and thus enables to make the configuration of the BVI noise reduction apparatus extremely simple.

BRIEF DESCRIPTION OF THE DRAWINGS

[0026] FIG. 1 is a schematic diagram showing configuration of one embodiment of the BVI noise reduction apparatus for helicopters according to the present invention, as shown in a side view of the rotor system.

[0027] FIG. 2 (a) and FIG. 2 (b) are illustrations showing the state in which the tab of the BVI noise reduction apparatus of the embodiment described above advances and the state in which the tab retreats, respectively, as viewed in a plane view with a part of the top surface of the rotor blade lacking.

[0028] FIG. 3 (a) and FIG. 3 (b) are illustrations showing the state in which the tab of the BVI noise reduction apparatus of the embodiment described above advances and the state in which the tab retreats, respectively, as shown in a cross-sectional view of the rotor blade.

[0029] FIG. 4 is a constituent drawing showing the generator and the control device of the BVI noise reduction apparatus of the embodiment described above, with the actuator.

[0030] FIG. 5 (a) and FIG. 5 (b) are illustrations showing the state in which the tab of the BVI noise reduction apparatus of the embodiment described above advances and the state in which the tab retreats, respectively, as shown in a perspective view of the rotor blade.

[0031] FIG. 6 (a) and FIG. 6 (b) are illustrations showing pressure distribution around the rotor blade in the state in which the tab of the BVI noise reduction apparatus of the embodiment described above advances and the state in which the tab retreats, respectively.

[0032] FIG. 7 (a) and FIG. 7 (b) are illustrations showing the state in which the tab of the BVI noise reduction apparatus of one variation of the embodiment described above advances and the state in which the tab retreats, respectively, as shown in a cross-sectional view of the rotor blade.

[0033] FIG. 8 (a) and FIG. 8 (b) are schematic illustrations showing the states in which the tab of the BVI noise reduction

apparatus of another embodiment advances and retreats, respectively, as shown in the top view of the rotor blade.

[0034] FIG. 9 is an illustration showing the tab of the BVI noise reduction apparatus of the embodiment described above, as shown in a cross-sectional view of the rotor blade.

[0035] FIG. 10 is an illustration showing pressure distribution around the rotor blade in the state in which the tab of the BVI noise reduction apparatus of the embodiment described above is advanced, compared with the case of the tab of the former embodiment and with the case where there is no such tab.

[0036] FIG. 11 (a) and FIG. 11 (b) is an illustration showing effect of centrifugal force in the state in which the tab of the BVI noise reduction apparatus of the embodiment described above is advanced.

[0037] FIG. 12 (a) is a schematic illustration showing the state in which the tab of the BVI noise reduction apparatus of one variation of the embodiment described above advances, as shown in the top view of the rotor blade, and FIG. 12 (b) is a cross-sectional view of the rotor blade taken along line D-D of FIG. 12 (a).

[0038] FIG. 13 is a perspective view of configuration of the actuator of yet another embodiment of the BVI noise reduction apparatus according to the present invention.

[0039] FIG. 14 is a plane view showing configuration of the BVI noise reduction apparatus of the embodiment described above.

[0040] FIG. 15 is a cross-sectional view of the rotor blade taken along line E-E of FIG. 14.

[0041] FIG. 16 (a) is a cross-sectional view of the rotor blade taken along line F-F of FIG. 14 in the state in which the tab retreats the most, and FIG. 16 (b) is a cross-sectional view of the rotor blade taken along line F-F of FIG. 14 in the state in which the tab advances the most.

[0042] FIG. 17 is an illustration showing the condition in which the Blade Vortex Interaction (BVI) noise is generated.

[0043] FIG. 18 (a) is an illustration showing the positional relationship between the blade tip vortex and the rotor blade before the rotor blade enters the blade tip vortex, and FIG. 18 (b) is an illustration showing pressure distribution on the top surface of the blade in the positional relationship described in FIG. 18 (a).

[0044] FIG. 19 (a) is an illustration showing the positional relationship between the blade tip vortex and the rotor blade when the rotor blade enters the blade tip vortex, and FIG. 19 (b) is an illustration showing pressure distribution on the top surface of the blade in the positional relationship described in FIG. 19 (a).

BEST MODE FOR CARRYING OUT THE INVENTION

[0045] The present invention will be further described with reference to preferred embodiments shown in the accompanying drawings. Now, FIG. 1 is a schematic diagram showing configuration of one embodiment of the BVI noise reduction apparatus for helicopters according to the present invention, as shown in a side view of the rotor system. FIG. 2 (a) and FIG. 2 (b) are illustrations showing the state in which the tab of the BVI noise reduction apparatus of the embodiment advances and the state in which the tab retreats, respectively, as viewed in a plane view with a part of the top surface of the rotor blade lacking. FIG. 3 (a) and FIG. 3 (b) are illustrations showing the state in which the tab of the BVI noise reduction apparatus of the embodiment advances and the state in which

the tab retreats, respectively, as shown in a cross-sectional view of the rotor blade. FIG. 4 is a constituent drawing showing the generator and the control device of the BVI noise reduction apparatus of the embodiment, with the actuator. FIG. 5 (a) and FIG. 5 (b) are illustrations showing the state in which the tab of the BVI noise reduction apparatus of the embodiment advances and the state in which the tab retreats, respectively, as shown in a perspective view of the rotor blade. FIG. 6 (a) and FIG. 6 (b) are illustrations showing pressure distribution around the rotor blade in the state in which the tab of the BVI noise reduction apparatus of the embodiment described above advances and the state in which the tab retreats, respectively.

[0046] As shown in FIG. 1 to FIG. 3, the BVI noise reduction apparatus of this embodiment includes a small tabular tab 3, which is disposed at each of trailing edges of the rotor blades 2 included in the rotor system 1 rotating with respect to a not-illustrated body of the helicopter. The tab is generally parallel to the top surface of a trailing edge of the rotor blade 2 and also in longitudinal direction of the rotor blade 2, slightly backward slanting from a traverse plane through a leading edge and a trailing edge of the rotor blade 2 dividing the rotor blade into top and bottom sections, so that the tab extends the trailing edge of the rotor blade 2 to the rear. The tab 3 is fastened by rollers 2a from top and bottom and from right and left, the tab 3 can advance and retreat between a position where the tab protrudes from the trailing edge of the rotor blade 2 as shown in FIG. 2 (a) and FIG. 3(a) and a position where the tab does not protrude from the trailing edge as shown in FIG. 2 (b) and FIG. 3 (b), with respect to rear of rotating direction of the rotor blade 2.

[0047] In addition, the BVI noise reduction apparatus of this embodiment is disposed in each of the rotor blades 2, and includes an actuator 4, which advances and retreats the tab 3 between a position where the tab protrudes from the trailing edge of the rotor blade 2 as shown in FIG. 2 (a) and in FIG. 3 (a) and a position where the tab does not protrude from the trailing edge of the rotor blade 2 as shown in FIG. 2(b) and in FIG. 3 (b), with respect to rear of rotating direction of the rotor blade 2.

[0048] As shown in FIG. 2 and FIG. 3, the actuator 4, which is disposed in the rotor blade 2, comprises the electromagnets 4a for pushing out the tab, each of which is pivoted to a trailing edge section of the tab 3 (a left edge section in FIG. 3) and by electromagnetism sorbs a steel plate 3a with its tip folded downward and springs 4b for pulling back the tab 3, which are also disposed in the rotor blade 2 and which continuously bias the tab toward a leading edge of the rotor blade 2 by pulling the trailing edge section of the tab 3. When all the electromagnets 4a for pushing out the tab are supplied with power, the actuator 4 advances the tab 3 to a position where the tab protrudes from the trailing edge of the rotor blade 2, as shown in FIG. 2 (a), FIG. 3 (a), and FIG. 5 (a), by those electromagnets 4a for pushing out the tab sorbing the steel plate 3a by electromagnetism, opposing the springs 4b for pulling back the tab. Also, when power supply to all the electromagnets 4a for pushing out the tab is stopped, the springs 4b for pulling back the tab, by their elasticity, retreat the tab 3 to a position where the tab does not protrude from the trailing edge of the rotor blade 2, as shown in FIG. 2 (b), FIG. 3 (b), and FIG. 5 (b). In addition, 2b in the figures indicates a stopper which is adjacent to the steel plate 3a and determines

the position where the tab retreats the most, which is a position where the tab does not protrude from the trailing edge of the rotor blade 2.

[0049] Furthermore, the BVI noise reduction apparatus of this embodiment, as shown in FIG. 4, includes a control device 5 which operates the actuator 4 so that the tab advances and retreats in response to rotating timing of the rotor blade 2 and a generator 6 which supplies power to the control device 5 and the actuator 4. The generator 6 has rotor coils 6a disposed in a drive shaft 7 which is included in the rotor system 1 and rotates the rotor blade 2 and stator coils 6b disposed in a mast 8 supporting the drive shaft rotatably, and supplies from the rotor coils 6a to the control device 5 electricity generated from energization to the stator coils 6b and from rotation of the rotor coils 6a accompanied by rotation of the drive shaft 7.

[0050] In addition, the BVI noise reduction apparatus of this embodiment includes a pressure sensor 9 (see FIG. 4) built in a position in longitudinal direction corresponding to the position of the tab 3 in a leading edge of each of the rotor blades 2 (a left end edge in FIG. 3). In addition, in this embodiment, the tab 3 and the pressure sensor 9 are disposed at a tip of the rotor blade 2 in longitudinal direction, which is at the highest part of the circumferential direction velocity of the rotor blade 2.

[0051] Further, the control device 5, as shown in FIG. 1, is disposed in a fairing 10 which is dome-shaped and secured to the upper end section of the drive shaft 7, and also as shown in FIG. 4, has a CPU (Central Processing Unit) 5a, a drive amplifier 5b and a not-illustrated memory which controls the operation of the CPU 5a. The CPU 5a is supplied power from the rotor coils 6a of the generator 6 to operate, detects the rotating position of each of the rotor blades 2 from the phase of electric power from the rotor coils 6a to a body of the helicopter, inputs a signal output by the pressure sensor 9 detecting pressure around the leading edge of the rotor blade 2, outputs a drive signal to moderate interaction between the blade tip vortex and the rotor blade by changing locally lift force of each of the rotor blades 2, exactly when each of the rotor blades 2 reaches the rotating position where it interacts with the blade tip vortex of another rotor blade 2 in front of the rotating direction. The drive amplifier 5b is supplied power from the rotor coils 6a of the generator 6 to operate and supplies drive power which is amplified from drive signals from the CPU 5a, to the electromagnets 4a of the actuator 4. In addition, the control device 5 has a not-illustrated battery for backup in the fairing 10 in order to keep data in the memory even when the drive shaft is not rotating.

[0052] In one embodiment of this BVI noise reduction apparatus, the actuator 4 built in the rotor blade 2 constituting the rotor system 1 advances and retreats the tab 3 set in the trailing edge section of the rotor blade 2, between a position where the tab protrudes from the trailing edge of the rotor blade 2 and a position where the tab does not protrude, generally parallel to the top surface of the rotor blade 2. And the control device 5 in the fairing 10 secured to the upper end section of the drive shaft 7 constituting the rotor system 1 operates each of the actuators 4 so that each of the tabs 3 advances and retreats in response to the rotating timing of each of the rotor blades 2.

[0053] Therefore, the BVI noise reduction method and apparatus of this embodiment, advances each of the tabs 3 from a trailing edge of the rotor blade 2 to the rear exactly when each of the rotor blades 2 reaches the rotating position

where it interacts with the blade tip vortex of another rotor blade 2 in front of the rotating direction and by doing so locally increases lift force of the rotor blade 2 compared to when the tab 3 in FIG. 6 (b) has retreated, as Line A in FIG. 6(a) shows pressure distribution with + as positive pressure and - as negative pressure, and changes instantly pressure around a leading edge of the rotor blade 2. The increased lift force and changed pressure cause such torsion on the rotor blade that the attack angle increases along the entire rotor blade. This strengthens a downdraft current (down wash) over the entire rotor blade, sweeps downward the blade tip vortex and also locally changes height of the rotor blade. Thus, interaction between the blade tip vortex and the rotor blade 2 can be moderated and the BVI noise can be reduced.

[0054] In addition, because not so much control force is required for such advance and retreat of the tab 3 from a trailing edge of the rotor blade 2 with respect to rear of rotating direction, the actuator 4 to operate the tab 3 can be easily configured to be small enough to be set in the rotor system, especially in the rotor blade 2, and also high response of the tab 3 can be achieved readily.

[0055] Furthermore, the BVI noise reduction method and apparatus of this embodiment includes the generator 6 which has the rotor coils 6a provided in the drive shaft 7 which is included in the rotor system 1 and rotates the rotor blade 2 and which supplies electric power generated from the rotating drive shaft 7 from the rotor coils 6a to the actuator 4. Therefore, it is unnecessary to provide the mast 8 supporting the drive shaft 7 with a collector ring for supplying electricity to the actuator 4, and the rotor system can be equipped with an independent noise reduction device. Thus, potential cause for the noise reduction apparatus to break down may be reduced, its reliability increased, and its maintenance check simplified.

[0056] In addition, in the BVI noise reduction method and apparatus of this embodiment, the tab 3 can automatically spring back to the neutral position with elasticity of the springs 4b. Thus, maneuverability of a typical helicopter can be secured.

[0057] Additionally, in the BVI noise reduction method and apparatus of this embodiment, the tab 3 disposed at the tip of the rotor blade 2 in longitudinal direction is placed at the highest part of the circumferential direction velocity of the rotor blade 2. Therefore, even a slightest advance or retreat of the tab can make the rotor blade go up and down, the actuator 4 can be lighter and smaller.

[0058] Further, according to the BVI noise reduction method and apparatus of this embodiment, the tab 3 provided in a trailing edge section of the rotor blade 3 advances and retreats between a position where the tab protrudes from the trailing edge and a position where the tab does not, generally parallel to the top surface of the rotor blade 2, with respect to rear of rotating direction of the rotor blade 2. Therefore, as pressure distribution is shown in FIG. 6 (a) by solid line, bigger lift force can be achieved, compared to the case (as shown by phantom line in the figure) in which the tab protrudes parallel to a traverse plane through the leading edge and the trailing edge of the rotor blade 2 dividing the rotor blade into top and bottom sections.

[0059] In addition, according to the BVI noise reduction method and apparatus of this embodiment, lift force can be controlled with more appropriate timing, because undesired adverse lift force of the initial stage operation (lift force which is generated until the vortex by a spoiler reaches a trailing edge of the rotor blade) is not generated, compared to the case in which lift force of the rotor blade is controlled by a spoiler protruding from top and bottom surfaces of the rotor blade, for example.

[0060] FIG. 7 illustrates one variation of the BVI noise reduction apparatus of the embodiment described above. In this embodiment, the actuator 4 also has the electromagnets 4a for pulling back the tab 3. According to such variation, the tab 3 can be operated more rapidly, and high response of the tab 3 can be achieved more easily.

[0061] FIG. 8 (a) and FIG. 8 (b) are schematic illustrations showing the states in which the tab of the BVI noise reduction apparatus of another embodiment advances and retreats, respectively, as shown in the top view of the rotor blade. FIG. 9 is an illustration showing the tab of the BVI noise reduction apparatus of the embodiment described above, as shown in a cross-sectional view of the rotor blade. The same parts of the embodiment above are referred to as the same signs.

[0062] Thus, according to the BVI noise reduction apparatus of this embodiment, the tab 3 is provided in the rotor blade 2 to swing around the central axis of the supporting axis 11 between the position shown in FIG. 8 (a) where the tab protrudes from a trailing edge of the rotor blade 2 and the position shown in FIG. 8 (b) where the tab does not, and advances and retreats with respect to rear of rotating direction. The tab 3 is fan-shaped and is positioned at the rotor blade 2 in such direction that the tab becomes wider as the tab gets closer to a tip of the rotor blade 2 (the upper end in FIG. 8), and also a narrower part in the vicinity of the pivot of the fan is secured to the rotor blade 2 by the supporting axis 11.

[0063] In addition, according to the BVI noise reduction apparatus of this embodiment, a counterweight 12 is provided in the part of the tab 3 which is narrower than the supporting axis 11. The actuator 4, which is made from electromagnetic solenoid with an electromagnet, for example, as well as in the other embodiments above, is disposed to add driving force for the tab 3 to advance and retreat at the vicinity of the supporting axis 11.

[0064] Further, the BVI noise reduction apparatus of this embodiment, as shown in FIG. 9, the supporting axis 11 slants such way that the supporting axis gets closer to the rear of the rotor blade as the supporting axis gets more upward or downward in up-and-down direction of the rotor blade. The tab 3 is pivoted to the rotor blade 2 to swing around the supporting axis 11. In points other than these the apparatus is configured to be the same as the other embodiments described above.

[0065] According to such configuration of these embodiments, as well as the other embodiments described above, the BVI noise can be reduced, the support structure of the tab 3 can be a simple swinging type, and also weight of the rotor blade and increase of the cost can be restrained. Also, because the tab 3 is fan-shaped and positioned at the rotor blade 2 in such direction that the tab becomes wider as the tab gets closer to the tip of the rotor blade 2, and a narrower part in the vicinity of the pivot of the fan is pivoted to the rotor blade 2, the rotating direction velocity, in other words circumferential velocity, becomes higher as it gets closer to the tip of the rotor blade, and the tab is exposed to air current at higher rotating direction velocity to obtain more air force, and eventually the BVI noise can be reduced more effectively.

[0066] Now, FIG. 10 is an illustration showing pressure distribution around the rotor blade L1 in the state in which the tab of the BVI noise reduction apparatus of the embodiment described above is advanced, compared with pressure distribution L2 in the case of the tab of the former embodiment and with pressure distribution in the case where there is no such tab. It is clear from this figure too that the BVI noise reduction apparatus of this embodiment can more effectively reduce the BVI noise.

[0067] However, because a blade tip vortex is generated in the descending current around a tip, an attack angle of the

rotor blade is relatively small. Therefore, a position where lift force can be obtained effectively is a position which is a little closer to the base than the tip, as seen in the pressure distribution of FIG. 10.

[0068] Further, according to the apparatus of this embodiment, the actuator 4 adds driving force for the tab 3 to advance and retreat at the vicinity of the supporting axis of the tab 3. So, operation stroke of the actuator 4 can be small and the actuator 4 can be more compact. Also, since it is further away from a tip of the rotor blade 2, the actuator 4 can be operated at a position where centrifugal force is smaller, and load on the actuator 4 can be reduced.

[0069] Further, according to the apparatus of this embodiment, the tab 3 is pivoted to the rotor blade 2 to swing around the supporting axis 11 which slants such way that the supporting axis gets closer to the rear of the rotor blade as the supporting axis gets more upward in up-and-down direction of the rotor blade. So, the tab 3 can have a projecting angle other than 0 degree off the horizontal direction of the rotor blade, and more air force can be obtained with the camber effect, and consequently the BVI noise can be reduced effectively.

[0070] Furthermore, according to the apparatus of this embodiment, a counterweight is provided at the part of the tab 3 where the tab is narrower than at the part pivoted by the supporting axis 11. So, as seen in FIG. 11, an element of centrifugal force CF given to the counterweight 12 around the central axis of the supporting axis 11 can moderate or offset an element of centrifugal force CF given by the rotating rotor blade 2 to the centroid CG of the tab 3 around the supporting axis 11. Also, stiffness of the supporting axis 11 and of the structure around it and of the movable part of the actuator can be reduced and load on the actuator also can be reduced.

[0071] FIG. 12 (a) is a schematic illustration showing the state in which the tab of the BVI noise reduction apparatus of one variation of the embodiment described above is advanced, as shown in the top view of the rotor blade. FIG. 12 (b) is a cross-sectional view of the rotor blade taken along D-D of FIG. 12 (a). According to the BVI noise reduction apparatus of this variation, the actuator 4 has a rack 4c coupled into the tab 3 by a pin to swing and a transmission shaft 4e which includes a pinion 4d engaged into the rack 4c and also which extends in longitudinal direction of the rotor blade 2 and which is pivoted by the rotor blade and also has, for example, a motor which turns the transmission shaft 4e. The apparatus of this embodiment is different from the other embodiments in these respects, and configured to be the same as the others in other respects.

[0072] According to the BVI noise reduction apparatus of this variation, a motor, for example, which turns the transmission shaft 4e of the actuator 4, can be operated at a position where centrifugal force is smaller and load on the actuator 4 can be reduced, because it is further away from the tip of the rotor blade 2.

[0073] FIG. 13 is a perspective view of configuration of the actuator of yet another embodiment of the BVI noise reduction apparatus according to the present invention. FIG. 14 is a plane view showing configuration of the BVI noise reduction apparatus of the embodiment described above. FIG. 15 is a cross-sectional view of the rotor blade taken along line E-E of FIG. 14. FIG. 16 (a) is a cross-sectional view of the rotor blade taken along line F-F of FIG. 14 in the state in which the tab is retreated the most, and FIG. 16 (b) is a cross-sectional view of the rotor blade taken along line F-F of FIG. 14 in the state in which the tab is advanced the most. The BVI noise reduction apparatus of this embodiment, unlike the embodi-

ment shown in FIG. 8, the tab 3, which is not fan-shaped but rectangular, is pivoted to the rotor blade 2 by the supporting axis 11 to swing.

[0074] In addition, according to the BVI noise reduction apparatus of this embodiment, like the variation described above, the actuator 4 has a rack 4c coupled into the tab 3 by a pin and a transmission shaft 4e which has a pinion 4d engaged into the rack 4c and which extends from the base to the tip in longitudinal direction of the rotor blade 2 and which is pivoted to the rotor blade 2 and a linkage 4f which is in conjunction with, for example, a swash plate and set around the drive shaft 7 and works as a control device and rotates the transmission shaft 4e so that the tab advances and retreats in response to rotating timing of the rotor blade.

[0075] According to the BVI noise reduction apparatus of another embodiment, the linkage 4f works in conjunction with a swash plate, rotates the transmission shaft 4e, for example, by moving a lever at the end of the transmission shaft 4e, in response to rotating timing of the rotor blade 2, and advances and retreats the tab 4 in response to rotating timing of the rotor blade 2. Therefore, electric system is unnecessary for the control device, so the configuration of the BVI noise reduction apparatus can be extremely simplified.

[0076] The present invention is not to be limited to the embodiments described and illustrated above. For instance, according to the present invention, the pressure sensor 9 and CPU 5a may be omitted and the generator 6 may work also as a control device. Also, electric power may be supplied directly from the rotor coils 6a to the actuator 4, or through a drive amplifier, and the actuator may be advanced and retreated by phase change of output electricity of the coils 6a.

[0077] In addition, according to the present invention, the tab 3 may advance and retreat from a trailing edge of the rotor blade 2 to the rear, diagonally outward with respect to the radial direction of the rotating center of the rotor blade 2. Thus, pressing force given to the rollers 2a from the tab 3 with centrifugal force of the rotating rotor blade 2 when the tab 3 advances and retreats can be reduced, guiding force of the tab 3 can be reduced.

[0078] Further, according to the present invention, the tab 3 may be placed at a position where the tab protrudes from a trailing edge of the rotor blade 2, with the tab 3 and the trailing edge of the rotor blade 2 apart from one another. Thus, with lift force increasing, the tab 3 may be lighter, its inertia force reduced, driving force of the actuator 4 smaller, and the actuator lighter and more compact.

[0079] Furthermore, according to the present invention, for example, lift force of the rotor blade 2 may be fine-adjusted by shortening the protruding length of the tab 3, for example, by energizing some of the electromagnets 4a or by stop energizing some of them. Also, instead of using the electromagnets 4a and the steel plate 3a, an electromagnetic solenoid may be used, and the core loosely inserted into the coil may be advanced and retreated.

[0080] In addition, the tab of the present invention can not only reduce the BVI noise but also adjust lift force of each of the rotor blades instead of a flap provided in each of the rotor blades and can restrain the vibration of the rotor system. Also, it can longer prevent air current from breaking away from each of the rotor blades and enhance operation efficiency of the rotor system.

INDUSTRIAL APPLICABILITY

[0081] According to this BVI noise reduction method and apparatus for a helicopter, an actuator provided in the rotor system including the rotor blade is operated to increase lift force of the rotor blade by advancing a tab to a position where

the tab protrudes from a trailing edge of the rotor blade and to decrease lift force back to the former condition by retreating the tab to a position where the tab does not protrude from the trailing edge of the rotor blade. Thus, interaction between the blade tip vortex and the rotor blade can be moderated by locally changing height of the rotor blade, and the BVI noise can be reduced.

[0082] In addition, not so much control force is required for advance and retreat of the tab from the trailing edge of the rotor blade with respect to rear of rotating direction, the actuator to operate the tab can be configured to be small enough to be set in the rotor system, and high response of the tab can be easily achieved.

1. A BVI noise reduction method for a helicopter providing:

- a tab which can advance and retreat with respect to rear of rotating direction of a rotor blade between a position where said tab protrudes from a trailing edge of said rotor blade and a position where said tab does not;
- an actuator to advance and retreat said tab in a rotor system including said rotor blade rotating with respect to a body of the helicopter;
- wherein said actuator is operated to advance and retreat said tab in response to rotating timing of said rotor blade, when reducing the BVI noise of said rotor blade of a helicopter.

2. The BVI noise reduction method for a helicopter according to claim 1, providing a coil for a generator in a drive shaft which is included in the rotor system and rotates said rotor blade; wherein electric power generated by said generator by rotating said drive shaft is supplied from said coil to said actuator.

3. The BVI noise reduction method for a helicopter according to claim 2, wherein said actuator is operated to advance and retreat said tab, so that said rotor blade following the preceding rotor blade avoids a blade tip vortex generated from said preceding rotor blade, based on the rotating timing with which said rotor blade following the preceding rotor blade approaches the blade tip vortex generated from said preceding rotor blade and which is detected from a phase of the electric power generated from said generator.

4. The BVI noise reduction method for a helicopter according to any one of claim 1 to claim 3, wherein excrecence quantity of said tab is controlled, based on an output signal from a pressure sensor provided in a leading edge of said rotor blade.

5. The BVI noise reduction method for a helicopter according to any one of claim 1 to claim 4, wherein said tab is provided in said rotor blade so that it can swing around a specified axis between a position where said tab protrudes from a trailing edge of said rotor blade and a position where said tab does not and can advance and retreat with respect to rear of rotating direction of said rotor blade.

6. A BVI noise reduction apparatus for a helicopter to reduce the BVI noise of a rotor blade (2) of a helicopter comprising:

- a tab (3) which is provided in said rotor blade and can advance and retreat with respect to rear of rotating direction of said rotor blade between a position where said tab protrudes from a trailing edge of said rotor blade and a position where said tab does not;

an actuator (4) which is provided in a rotor system (1) which includes said rotor blade and rotates with respect to a body of the helicopter and which advances and retreats said tab; and

a control device (S) which is provided in said rotor system and operates said actuator so that said tab advances and retreats in response to rotating timing of said rotor blade.

7. The BVI noise reduction apparatus for a helicopter according to claim 6, including a generator (7) which has a coil (6a) provided in a drive shaft (7) which is included in said rotor system and rotates said rotor blade, and which supplies electric power generated by rotation of said drive shaft, from said coil to said actuator.

8. The BVI noise reduction apparatus for a helicopter according to claim 5 or claim 7, said actuator advances and retreats said tab by an electromagnet (4a) for pushing out said tab and a spring (4b) for pulling back said tab.

9. The BVI noise reduction apparatus for a helicopter according to any one of claim 5 to claim 8, wherein said tab (3) is disposed at a tip of said rotor blade (2).

10. The BVI noise reduction apparatus for a helicopter according to any one of claim 5 to claim 9, wherein said tab (3) is provided in said rotor blade (2) so that said tab can swing around a specified axis between a position where said tab protrudes from a trailing edge of said rotor blade and a position where said tab does not, and can advance and retreat with respect to rear of rotating direction of said rotor blade.

11. The BVI noise reduction apparatus for a helicopter according to claim 10, wherein said tab (3) is fan-shaped and is positioned at said rotor blade (2) in such direction that said tab becomes wider as said tab gets closer to a tip of said rotor blade, and a narrower part in the vicinity of a linchpin of said fan is pivoted to said rotor blade.

12. The BVI noise reduction apparatus for a helicopter according to any one of claim 5 to claim 11, wherein said actuator (4) gives driving force for advance and retreat at the vicinity of said pivoted part of said tab (3).

13. The BVI noise reduction apparatus for a helicopter according to claim 11 or claim 12, wherein said tab (3) is provided with a counterweight (12) at a position where said tab is narrower than at said pivoted part.

14. The BVI noise reduction apparatus for a helicopter according to claim 10, wherein said tab (3) is pivoted to said rotor blade (2) to be swingable around said supporting axis (11) which slants such way that said supporting axis gets closer to rear of said rotor blade (2) as said supporting axis gets more upward in up-and-down direction of said rotor blade.

15. The BVI noise reduction apparatus for a helicopter according to any one of claim 5 to claim 14, wherein said actuator (4) comprises;

- a rack (4c) coupled with said tab (3);
- a transmission shaft (4e) which has a pinion (4d) engaged into said rack and which extends from a base to a tip of said rotor blade (2) and which is supported by said rotor blade 2 pivotably; and
- a linkage (4f) which is provided in said rotor system (1) and functions also as said control device, and rotates said transmission shaft so that said tab advances and retreats in response to rotating timing of said rotor blade.

* * * * *