

(19) World Intellectual Property Organization
International Bureau



(43) International Publication Date
24 July 2003 (24.07.2003)

PCT

(10) International Publication Number
WO 03/059152 A2

- (51) International Patent Classification⁷: A61B
- (21) International Application Number: PCT/US03/01050
- (22) International Filing Date: 14 January 2003 (14.01.2003)
- (25) Filing Language: English
- (26) Publication Language: English
- (30) Priority Data:
60/347,336 14 January 2002 (14.01.2002) US
- (71) Applicant: NMT MEDICAL, INC. [US/US]; 27 Wormwood Street, Boston, MA 02210 (US).

(81) Designated States (national): AE, AG, AL, AM, AT, AU, AZ, BA, BB, BG, BR, BY, BZ, CA, CH, CN, CO, CR, CU, CZ, DE, DK, DM, DZ, EC, EE, ES, FI, GB, GD, GE, GH, GM, HR, HU, ID, IL, IN, IS, JP, KE, KG, KP, KR, KZ, LC, LK, LR, LS, LT, LU, LV, MA, MD, MG, MK, MN, MW, MX, MZ, NO, NZ, OM, PH, PL, PT, RO, RU, SC, SD, SE, SG, SK, SL, TJ, TM, TN, TR, TT, TZ, UA, UG, UZ, VC, VN, YU, ZA, ZM, ZW.

(84) Designated States (regional): ARIPO patent (GH, GM, KE, LS, MW, MZ, SD, SL, SZ, TZ, UG, ZM, ZW), Eurasian patent (AM, AZ, BY, KG, KZ, MD, RU, TJ, TM), European patent (AT, BE, BG, CH, CY, CZ, DE, DK, EE, ES, FI, FR, GB, GR, HU, IE, IT, LU, MC, NL, PT, SE, SI, SK, TR), OAPI patent (BF, BJ, CF, CG, CI, CM, GA, GN, GQ, GW, ML, MR, NE, SN, TD, TG).

(72) Inventors: CHANDUSZKO, Andrzej, J.; 50 Woodward Street, South Boston, MA 02127 (US). OPOLSKI, Steven, W.; 330 Fiske Street, Carlisle, MA 01741 (US). RYAN, Carol, A.; 64 South Main Street, Topsfield, MA 01983 (US).

Published:
— without international search report and to be republished upon receipt of that report

(74) Agents: DIENER, Michael, A. et al.; Hale and Dorr LLP, 60 State Street, Boston, MA 02109 (US).

For two-letter codes and other abbreviations, refer to the "Guidance Notes on Codes and Abbreviations" appearing at the beginning of each regular issue of the PCT Gazette.

(54) Title: PATENT FORAMEN OVALE (PFO) CLOSURE METHOD AND DEVICE

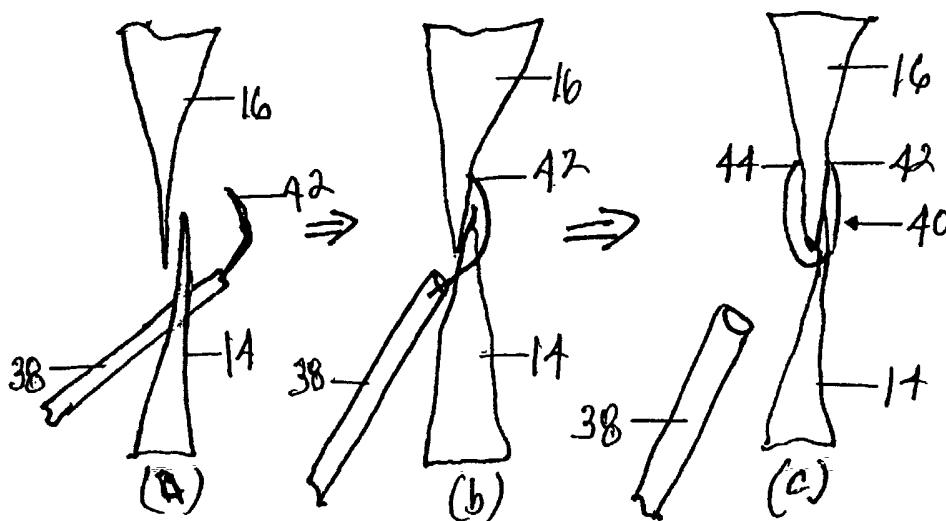

(57) Abstract: The present invention provides methods and devices for closing two overlapping layers of tissue in a mammalian heart, for example a patent foramen ovale (PFO). The closure devices may take a number of different forms and may be retrievable. In some embodiments, the closure devices may be delivered with a catheter capable of puncturing mammalian tissue.



WO 03/059152 A2

PATENT FORAMEN OVALE (PFO) CLOSURE METHOD AND DEVICE

Background of the Invention

[0001] A patent foramen ovale (PFO) as shown in Figure 1, is a persistent, one-way, usually flap-like opening in the wall between the right atrium **10** and left atrium **12** of the heart. Since left atrial (LA) pressure is normally higher than right atrial (RA) pressure, the flap typically stays closed. Under certain conditions, however, RA pressure can exceed LA pressure creating the possibility for right to left shunting that can allow blood clots to enter the systemic circulation. In utero, the foramen ovale serves as a physiologic conduit for right-to-left shunting. After birth, with the establishment of pulmonary circulation, the increased left atrial blood flow and pressure results in functional closure of the foramen ovale. This functional closure is subsequently followed by anatomical closure of the two over-lapping layers of tissue: septum primum **14** and septum secundum **16**. However, a PFO has been shown to persist in a number of adults.

[0002] The cause of ischemic stroke remains cryptogenic (of unknown origin) in approximately 40% of cases. Especially in young patients, paradoxical embolism via a PFO is considered in the diagnosis. While there is currently no proof for a cause-effect relationship, many studies have confirmed a strong association between the presence of a PFO and the risk for paradoxical embolism or stroke. In addition, there is good evidence that patients with PFO and paradoxical embolism are at increased risk for future, recurrent cerebrovascular events.

[0003] The presence of a PFO has no therapeutic consequence in otherwise healthy adults. In contrast, patients suffering a stroke or transient ischemic attack (TIA) in the presence of a PFO and without another cause of ischemic stroke are considered for prophylactic medical therapy to reduce the risk of a recurrent embolic event. These patients are commonly treated with oral anticoagulants, which have the potential for adverse side effects, such as hemorrhaging, hematoma, and interactions with a variety of other drugs.

[0004] In certain cases, such as when anticoagulation is contraindicated, surgery may be used to close the PFO. To suture a PFO closed requires attachment of septum secundum to septum primum with either an interrupted or a continuous stitch, which is the common way a surgeon shuts the PFO under direct visualization.

[0005] Nonsurgical closure of PFOs has become possible with the advent of umbrella devices and a variety of other similar mechanical closure designs, developed initially for percutaneous closure of atrial septal defects (ASD). These devices allow patients to avoid the potential side effects often associated with anticoagulation therapies.

[0006] Currently available designs of septal closure devices, however, present such drawbacks as technical complexity of implantation procedure, high complication rates (thrombus, fractures, conduction system disturbances, perforations, residual leaks), high septal profile, large masses of foreign material, and lack of anatomic conformability especially to the PFO flap-like anatomy, as most were originally designed to close ASD's, which are true holes. Additionally, some septal closure devices are complex to manufacture, which can result in lack of consistency in product performance.

Summary of the Invention

[0007] In one aspect, the present invention provides a method of closing two overlapping layers of tissue in a mammalian heart, *e.g.*, a patent foramen ovale (PFO), using a closure device that applies a compressive force to at least one of the layers of tissue. The closure device may be retrievable, such that it may be removed after a period of time sufficient to allow the overlapping layers of tissue to fuse together. If necessary to sufficiently close the length of the layers of tissue, multiple closure devices may be administered. The closure devices may be delivered with a catheter capable of puncturing mammalian tissue in at least one location.

[0008] The closure device of the present invention may take a number of different forms. For example, the closure device may have first and second ends, both of which may be capable of puncturing mammalian tissue. The device may be a structure such as a ring with a gap, a folded ring, at least one grappling hook member joined to at least one curved arm by a joiner member, opposed grappling hook members joined by a central connecting member, a grappling hook member and a central connecting member, or a closure device anchor joined to a structure of sufficient diameter to hold the device in place against the overlapping layers of tissue. In some embodiments of the present invention, the closure device is sized and shaped such that it extends from septum secundum in the left atrium, into the left atrium, through septum

primum, into the right atrium, and to septum secundum in the right atrium. Some retrievable devices include elongate tethers to facilitate their removal. Each of these devices has certain advantages, and one skilled in the art will be capable of selecting the device appropriate for a given application.

[0009] The ends of the closure device may also take a number of different forms. For example, at least one end may form a disc or a closure device anchor, such as a coil, hook, or corkscrew. These end structures help to maintain the device in place. One of the ends, for example the second end, may take the form of a knot or a structure similarly capable of holding the device in place and applying a sufficient compressive force to the overlapping layers of tissue. In some embodiments, the end structure may be adjusted to alter the compressive force applied to the overlapping layers of tissue. As previously mentioned, either or both of the first and second ends may be capable of puncturing mammalian tissue. In some embodiments, the first end of the device is a septal puncture needle.

[0010] The closure device may be formed of any of several materials, such as flexible polymer materials, bioabsorbable materials, shape memory materials, metals, noble metals, or swellable foams. In particular embodiments, the device includes nitinol. Some of the devices are formed from a single piece of material, while others are formed from multiple pieces of material joined together.

[0011] Some closure devices according to the present invention are intended to puncture septum primum upon insertion into the heart. For example, such a device may be inserted into the right atrium of the heart and puncture septum primum to enter the left atrium of the heart. At this point, the first end of the device may simply be deployed into the left atrium, or the first end of the device may be deployed into the left atrium and at least partially puncture septum secundum. In those embodiments where the first end of the device at least partially punctures septum secundum, the first end may be embedded in septum secundum or may completely puncture septum secundum such that the first end extends into the right atrium. The second end of the device may then be positioned against septum secundum in the right atrium, thereby providing a compressive force to the septal tissues. In other embodiments, the second end is also positioned in the left atrium while another portion of the device, such as a fold, is positioned in the right atrium, thereby compressing the septal tissues between the device.

[0012] Alternatively, some closure devices according to the present invention are intended to be inserted between the overlapping layers of tissue, *e.g.* through the PFO tunnel, to enter the left atrium. In these embodiments, the first end of the device is then deployed in the left atrium and the second end of the device is deployed in the right atrium, thereby providing a compressive force to the septal tissue. As discussed above, at least one of the ends of the device may partially puncture septum secundum.

[0013] These and other features will become readily apparent from the following detailed description wherein embodiments of the invention are shown and described by way of illustration.

Brief Description of the Drawings

[0014] Figure 1 is a diagrammatic sectional view of a Patent Foramen Ovale (PFO);

[0015] Figure 2 is a view in side elevation of the PFO closure device with mechanical anchors of the present invention;

[0016] Figures 3a, 3b and 3c illustrate the steps in the deployment of the PFO closure device of Figure 2;

[0017] Figure 4 is a view in side elevation of a second embodiment of the PFO closure device with mechanical anchors of the present invention;

[0018] Figures 5a, 5b and 5c illustrate the steps in the deployment of the PFO closure device of Figure 4;

[0019] Figure 6 is a view in side elevation of a catheter and septal puncture needle used to pierce septum primum;

[0020] Figure 7 is a view in side elevation of a needle anchor for PFO closure;

[0021] Figure 8 is a view in side elevation of a suture and anchor used for PFO closure;

[0022] Figure 9 is a diagram of multiple anchor placement for PFO closure;

[0023] Figures 10a, 10b and 10c illustrate the steps in the deployment of a rivet and suture type of PFO closure device;

[0024] Figures 11a, 11b, 11c and 11d illustrate the steps in the deployment of a removable PFO closure device;

[0025] Figures 12a, 12b and 12c illustrate the steps in the deployment of a multiple hook PFO closure device;

[0026] Figure 13 is a view in side elevation of an alternative structure of the second embodiment of the PFO closure device with mechanical anchors of the present invention;

[0027] Figure 14 is a view in side elevation of an alternative structure of the second embodiment of the PFO closure device with mechanical anchors of the present invention; and

[0028] Figures 15a, 15b, and 15c are an end face view from the right atrium, an end face view from the left atrium, and a side elevation view, respectively, of the deployed alternative structure of the second embodiment of the PFO closure device with mechanical anchors of the present invention.

Description of the Preferred Embodiments

[0029] Referring to Figures 2 and 3, a PFO closure device with mechanical anchors indicated generally at **18** includes opposed grappling hook members **20** and **22** connected by a central connecting member **24**. When the PFO closure device **18** is deployed, the grappling hook members **20** and **22** each include two or more curved hooks. In Figures 2 and 3, three curved hooks **26**, **28** and **30** form the grappling hook member **20** and three curved hooks **32**, **34** and **36** form the grappling hook member **22**. As shown in Figure 2, the grappling hooks **26**, **28**, **30**, **32**, **34**, and **36** extend radially from the central connecting member **24**. The grappling hooks of grappling hook members **20** and **22** have the same geometry but are rotated such that each grappling hook of grappling hook member **20** is situated precisely between two opposed grappling hooks of grappling hook member **22**. The angle between any two grappling hooks of grappling hook members **20** and **22** may be determined by the formula $360^\circ/(\text{number of hooks per grappling hook member})$. To fit within a catheter, these hooks may all be straightened outwardly and compressed to lie along the longitudinal axis of the central connecting member **24**. In this form, the PFO closure device extends longitudinally within a catheter **38**.

[0030] To deploy the PFO closure device **18**, the catheter **38** is inserted from the right atrium **10** through the PFO tunnel, *i.e.* between septum primum **14** and septum secundum **16**, into the left atrium **12**. As shown in Figure 3a, the grappling hook member **20** is deployed into the left atrium. Next, as shown in Figure 3b, the catheter **38** is drawn back into the right atrium and the grappling hooks **26**, **28** and **30** are drawn back and embedded in the left sides of septum primum and septum secundum. The central connecting member **24** extends at an angle through the PFO tunnel permitting septum primum and septum secundum to be drawn to the closed position and secured by the grappling hooks **26**, **28** and **30**. Finally, as shown in Figure 3c, the catheter **38** is drawn back to permit the grappling hook member **22** to deploy, and grappling hooks **32**, **34** and **36** pierce the right side of septum primum and septum secundum.

[0031] The grappling hook members **20** and **22** may be formed of flexible, spring-like, bioabsorbable polymer material so as to permit movement from the compressed straight shape to the curved hook shapes following deployment from the catheter **38**. The central connecting member **24** may also be formed of bioabsorbable material, such as an absorbable suture material, so the device will ultimately leave no foreign substance in either atrium. Alternatively, the grappling hook members **20** and **22** may be formed of spring metal or of a shape memory material, such as nitinol. When the PFO closure device is not formed of bioabsorbable material, it is possible to form the device with only the grappling hook member **20** and a central connecting member **24** so that the device is repositionable and retrievable. When the device is made of a bioabsorbable material or is not intended to be retrievable, the ends of grappling hooks **26**, **28**, **30**, **32**, **34** and **36** may further include a barb to maintain the device in the septal tissue. In some embodiments, the grappling hook members **20** and **22** serve as tissue scaffolds, and are covered with a vascular material, such as polyester, biological tissue, bioresorbable polymer, or spongy polymeric material.

[0032] As shown in Figure 3, the closure device will conform, at least to some extent, to the septal tissue that it compresses. The extent of this conformance depends upon the material from which the device was formed: a device formed of a spring metal or shape memory material will conform to the surrounding septal tissue to a lesser extent than one formed of a flexible, bioabsorbable polymer material.

[0033] Figure 4 shows a second embodiment of a PFO closure device with mechanical anchors indicated generally at **40**. This device, when deployed, forms a ring

hook design that terminates in two opposed, pointed ends **42** and **44**. The device may be straightened to pass through a catheter **38**. To deploy the device as shown in Figures 5a, 5b and 5c, the catheter is caused to pierce septum primum **14** and enter the left atrium where the pointed end **42** is deployed. Then, as shown in Figure 5b, the catheter is drawn back through septum primum to draw the device through septum primum and embed the pointed end **42** in the left side of septum secundum. Finally, as shown in Figure 5c, the catheter is withdrawn to fully deploy the PFO closure device and the pointed end **44** is embedded in the right side of septum secundum to compress septum primum and septum secundum together. As shown in Figures 4 and 5, the ring PFO closure device **40**, when deployed, may include a gap that is slightly smaller than the thickness of septum secundum into which it is embedded. In some embodiments, the opposed ends **42** and **44** of the deployed PFO closure device **40** contact each other or overlap.

[0034] As shown in Figures 13 and 14, closure device **40** may take alternative forms. For example, closure devices **90** and **100** are formed as partial rings terminating in two pointed ends **92** and **94** or **102** and **104** and having at least one fold therebetween. Closure devices **90** and **100** are deployed in a manner similar to that described above and shown in Figure 5. When deployed, the pointed ends **92** and **94** or **102** and **104** puncture the surface of septum secundum exposed in the left atrium and at least one of the folds contacts the surface of septum secundum exposed in the right atrium (Figures 15a and 15b). Septum primum and septum secundum are thus compressed between the pointed ends and at least one of the folds of the device (Figure 15c).

[0035] Multiple PFO closure devices **40**, **90** or **100** can be inserted until the physician is satisfied with the resultant PFO closure. Again, the PFO closure devices may be formed of flexible, bioabsorbable polymer material, spring metal, other spring-like non-bioabsorbable material, or shape memory material. The choice of material will affect the degree to which the device conforms to the surrounding septal tissue. As shown in Figures 4, 13, and 14, the PFO closure device may be a monolithic structure.

[0036] A PFO may also be closed with one or more sutures. As used in the art and indicated in the Figures, "suture" refers to a single connection used to hold two pieces of material or tissue together and need not be a continuous stitch. However, to suture a PFO closed has conventionally required the attachment of septum secundum to septum primum with a continuous stitch. This need for a continuous stitch can be

eliminated by implanting sutures across the PFO using implantable suture anchors. As shown in Figures 6 and 7, a catheter **46** is used to puncture septum primum and then septum secundum. In the case of septum primum, the puncture creates a hole through which the catheter can pass; in the case of septum secundum, the puncture may be a depression that does not pass through septum secundum. A single puncture may be made in septum secundum as shown in Figures 6-8, or, as subsequently described and shown in Figure 9, multiple punctures may be made. These punctures are made using a sharp pointed needle tip **48**. Following puncture to a desired depth, the catheter **46** surrounding the needle **48** is withdrawn and the needle component returns (most likely via shape memory) to its predetermined anchor-shape.

[0037] The anchors are most likely fabricated from a shape memory alloy, such as nitinol, although they could be made from a flexible, bioabsorbable polymer or a noble metal, each having their own advantage - no long term implant issues with bioabsorbable anchors and excellent radiopacity with anchors fabricated from a noble metal, such as platinum-iridium. The remainder of the suture may be formed of any suitable material, including wire, polymeric materials, and bioabsorbable materials.

[0038] The suturing method includes using a standard septal puncture technique to locate and puncture septum primum. Following this, several approaches exist. One would be that the septal puncture needle would be withdrawn from the catheter and the suturing system then delivered through the catheter (the septal needle catheter would maintain position across septum primum during the exchange). Alternatively, a wire could be placed through the septal needle catheter to maintain position and the suture system could be delivered over the wire, or the septal puncture needle could become part of the suture system. Following delivery of the suture system, the proximal end of the suture may then be tied off so as to secure the system in place and keep the PFO closed. As described below for the rivet design suture system and shown in Figure 10c, the proximal end of the suture may be formed into a knot, *i.e.* the end of the suture may be formed into a structure having a diameter larger than that of the catheter used to puncture septum primum so as to ensure that the suture system remains in place. Other suitable structures for the proximal end of the suture include, but are not limited to, coils, spirals, and other adjustable mechanisms. This structure should apply sufficient compression to hold septum primum and septum secundum together. The structure may

be adjustable, such that the level of compression may be altered as necessary. Multiple sutures may be inserted until the physician is satisfied with the PFO closure.

[0039] In Figure 8, a suture **50** is delivered through the septal needle catheter following the removal of the needle. A suture catheter **52** enters the left atrium through the septal needle catheter, is pulled back against septum secundum, setting the needle tip(s) **54** deep within it or through it, if it is thin enough. The tip could be either radiopaque, echogenic, or both, to be visible by x-ray (fluoroscopy) and/or cardiac echo. Once proper position is determined, the constricting system (a hypotube or a series of con-axial hypotubes in the embodiment where multiple needles are simultaneously delivered) is withdrawn, allowing the suture anchor **56** to form into a pre-determined shape tissue anchor, most likely via shape memory properties. The anchor **56** on the end of the suture **50** has been embedded in septum secundum and expands to anchor the suture, which passes through septum primum once the suture catheter is removed. The anchor shape can be one of many different options, including but not limited to a coil, hook, corkscrew, or grappling hook.

[0040] In those cases where a true puncture through septum secundum can be made, an anchor can be placed entirely in the right atrium, leaving nothing but suture in the left atrium. These anchors may be short strips or cylindrical rods made from a metallic or polymeric material that is biostable or bioabsorbable, or a piece of swellable foam, such as Ivalon.

[0041] In another embodiment, the septal needle catheter crosses septum secundum in multiple locations simultaneously. In this embodiment, the final result, as seen from the left atrium in an end face view of septum primum and septum secundum, would be as shown in Figure 9, where a plurality of spaced anchors **58** engage septum secundum.

[0042] A rivet design suture system **60** is shown in Figures 10a, 10b and 10c. Here a suture **62** and anchor **64** are contained within a catheter **66**, which pierces both septum secundum and septum primum. The anchor **64**, which is formed of a firm material, such as a metal disc, a small hook (such as the shape memory hooks previously described), or a piece of bio-absorbable polymer, is then deployed into the left atrium, and the suture **62** and catheter **66** are then pulled back as shown in Figure 10b to compress the two septa together. The suture **62** can then be knotted with knot **68**, as

shown in Figure 10c, to secure the system **60** in place to keep the PFO closed, *i.e.* the end of the suture may be formed into a structure having a diameter larger than that of the catheter used to puncture septum primum so as to ensure that the suture system remains in place. Other suitable structures for the second end of the suture include, but are not limited to, coils, spirals, other adjustable mechanisms. As shown in Figure 10c, this structure should apply sufficient compression to hold septum primum and septum secundum together. The structure may be adjustable, such that the level of compression may be altered as necessary. Multiple rivet systems can be inserted until a physician is satisfied with the PFO closure.

[0043] The PFO closure device of the present invention may be formed in a manner to facilitate removal once septum primum and septum secundum are fused. An exemplary removable PFO closure device **70** is deployed in the manner illustrated by Figures 11a - 11d. The PFO closure device **70** may be delivered by a delivery catheter or sheath **72** and includes a grappling hook member **74** joined to a curved arm **76** by an enlarged tip joiner member **78**. At least one of the grappling hook member and curved arm of the PFO closure device may be curved relative to the other. An elongate tether **80** is connected to the tip joiner member **78** and extends back through the catheter **72**. The tether **80** can be coated to minimize trauma to the veins.

[0044] To deploy the removable PFO closure device **70** according to one embodiment of the invention, the grappling hook member **74** is passed through septum primum **14** (Figure 11b), and the grappling hook, when free of the catheter, curves in a manner convex relative to the surface of septum secundum and penetrates septum secundum **16** (Figure 11c). Then, the grappling hook is drawn back toward the catheter by the tether **80** to apply tension to the tissue causing septum secundum to be drawn into contact with septum primum. Then the curved arm **76** is deployed (Figure 11d) and curves in a manner concave relative to septum secundum so as to engage septum secundum as the catheter is drawn back. The compressive force applied by the grappling hook and the curved arm hold septum primum and septum secundum tightly together. The grappling hook **74** and curved arm **76** are preferably formed of shape memory material, such as nitinol, so that they respond to body temperature when deployed from the catheter **72** to form the shape shown in Figure 11d.

[0045] Once the PFO closure device **70** is in place, the catheter **72** is withdrawn and the free end of the tether **80** is attached to a button subcutaneously and allowed to

remain in place for a period of time sufficient to allow the two septa to fuse together. Then the device is pulled through septum primum and into a recovery sheath by means of the tether **80** and removed.

[0046] The PFO closure device **70** can be deployed as shown in Figure 11 without the tether **80** to provide a free standing device with the grappling hook **74** and arm **76** being formed to press the two septa **14** and **16** together. The device may later be removed by a removal device, which grabs the joinder member **78** and draws the device through septum primum **14** and into a removal sheath.

[0047] Instead of a single opposed grappling hook **74** and curved arm **76**, the PFO closure device can include a plurality of opposed grappling hooks and curved arms radially extending in a spaced relationship from the joinder member **78**. Such a device **82** is shown in Figure 12. Here, the PFO closure device includes a plurality of grappling hooks **84** and a plurality of opposed curved arms **86** which are enclosed in a delivery catheter **72**. A small hole **88** is created in septum primum **14** to permit insertion of the catheter into the left atrium and the grappling hooks **84** are deployed as shown in Figure 12a. Then, the delivery catheter is drawn back to engage the hooks with both septum secundum and septum primum as shown in Figure 12b. Next, as shown in Figure 12c, the catheter is drawn away to release the curved arms **86**, which engage the two septa in opposed relationship to the grappling hooks **84**. The device may have many, *e.g.* eight, opposed grappling hooks and curved arms. As in the case of the PFO closure device **70**, the device **82** may be removed by grasping the tip joinder member **78**.

[0048] The device **82** may be permanently deployed by inserting the catheter through the PFO channel between septum secundum and septum primum into the left atrium to deploy the grappling hooks **84**. Then, the catheter is withdrawn back through the PFO channel to release the curved arms **86**.

[0049] Having described embodiments of the present invention, it should be apparent that the invention is capable of other and different embodiments and may be modified in various respects, all without departing from the scope of the invention as defined by the appended claims. Accordingly, the foregoing drawings and description are to be regarded as illustrative in nature and not in a restrictive or limiting sense.

[0050] What is claimed is:

1. A method of closing septum primum and septum secundum in a mammalian heart, comprising:
 - (a) inserting a closure device into a right atrium of said heart, said device including first and second ends;
 - (b) puncturing septum primum and passing a portion of said closure device through septum primum into a left atrium of said heart;
 - (c) puncturing septum secundum at said first end of said closure device after said closure device has passed through septum primum; and
 - (d) positioning said second end of said closure device against septum secundum in the right atrium such that said closure device provides a compressive force to compress at least one of septum primum and septum secundum therebetween.
2. The method of claim 1, wherein said closure device is delivered with a catheter that includes a septal puncture needle capable of puncturing mammalian tissue.
3. The method of claim 2, wherein puncturing septum secundum includes puncturing so that said first end is embedded in and does not extend through septum secundum.
4. The method of claim 3, wherein said puncturing includes the septal needle catheter puncturing septum secundum in multiple locations simultaneously, the method further comprising embedding a plurality of pieces of the closure device in septum secundum.
5. The method of claim 2, wherein puncturing septum secundum includes completely puncturing septum secundum so that said first end extends into the right atrium.
6. The method of claim 5, wherein said puncturing includes the septal needle catheter puncturing septum secundum in multiple locations simultaneously, the method further comprising deploying a plurality of pieces of the closure device into the right atrium.
7. The method of claim 1, wherein said puncturing septum primum and passing a portion of said closure device through septum primum constitutes one step.
8. The method of claim 1, wherein said puncturing septum primum and passing a portion of said closure device through septum primum constitutes two steps.
9. The method of claim 1, wherein said first end of said closure device includes a shape memory material.
10. The method of claim 9, wherein said shape memory material includes nitinol.

11. The method of claim 1, wherein said closure device is formed of a material selected from the group consisting of bioresorbable materials, noble metals, shape memory materials, metals, polymeric materials, or swellable foams.
12. The method of claim 1, wherein said first end is formed into a coil, hook, corkscrew, or other anchor.
13. The method of claim 1, wherein said second end is formed into a knot, coil, spiral, or other adjustable mechanism sufficient to hold said closure device in place.
14. The method of claim 1, wherein said second end of said closure device has a structure that is adjustable to alter the compressive force applied to septum primum and septum secundum.
15. The method of claim 1, wherein steps (a) through (d) are repeated at least once for multiple closure devices.
16. The method of claim 1, wherein said closure device is shaped as a ring with a gap, the ring being positioned so that said first end punctures and embeds into said septum secundum on the left atrium side and said second end punctures and embeds into said septum secundum on the right atrium side, said septum secundum being compressed in said gap.
17. The method of claim 16, wherein said ring consists of a single monolithic piece.
18. The method of claim 16, wherein said inserting includes providing the closure device in a catheter, said closure device being elongated so that the gap between said first and second ends is enlarged.
19. The method of claim 1, wherein said closure device is shaped as a ring with first and second ends and at least one fold therebetween, said ring being positioned so that said first and second ends puncture septum secundum on the left atrium side and said at least one fold contacts septum secundum in the right atrium, septum secundum being compressed between said first and second ends and said at least one fold.
20. The method of claim 1, wherein the device has a first piece including said first end, and a separate second piece including said second end, said first and second pieces connected together at a location in the right atrium, at least one of said pieces being curved relative to the other said piece.
21. The method of claim 20, wherein said first piece is convex relative to septum secundum and said second piece is concave relative to septum secundum.

22. The method of claim 20, further comprising retrieving and removing said closure device after it has been deployed.
23. The method of claim 1, further comprising retrieving and removing said closure device after it has been deployed.
24. The method of claim 1, wherein said closure device includes a grappling hook member joined to at least one curved arm by an enlarged-tip joiner member, which member is connected to an elongate tether, said grappling hook member including at least one grappling hook capable of being reversibly and distally elongated, wherein puncturing septum secundum includes deploying said grappling hook member such that said at least one grappling hook is embedded into the surface of septum secundum in the left atrium, applying tension to said tether such that said grappling hook draws septum secundum into contact with septum primum, and said positioning includes deploying said at least one curved arm such that said curved arm engages the surface of septum secundum exposed in the right atrium.
25. The method of claim 24, wherein said grappling hook member includes a plurality of grappling hooks and, upon deploying said grappling hook member in the left atrium, said plurality of grappling hooks are embedded in the surfaces of both septum primum and septum secundum in the left atrium.
26. The method of claim 25, wherein said closure device includes a plurality of curved arms and, upon deployment in the right atrium, said plurality of curved arms engage both the surfaces of septum primum and septum secundum exposed in the right atrium.
27. The method of claim 24, wherein said inserting includes providing the closure device in a catheter, said closure device being elongated such that said first and second ends are distally elongated relative to said joiner member.
28. The method of claim 24, further comprising retrieving said closure device after a period of time sufficient to allow septum primum and septum secundum to fuse together by grabbing said joiner member with a removal device and withdrawing said grappling hook member of said closure device through septum primum.
29. The method of claim 24, further comprising withdrawing said catheter from said heart and attaching said tether to a subcutaneous button and retrieving said closure device after a period of time sufficient to allow septum primum and

- septum secundum to fuse together by pulling said device through septum primum and into a recovery sheath by means of the tether.
30. A device for closing two overlapping layers of septum primum and septum secundum dividing a left atrium and a right atrium in a mammalian heart, said device having first and second ends, wherein said device is sized and shaped to extend from septum secundum, into the left atrium, through septum primum, and into the right atrium, said first and second ends cooperating to provide a compressive force to the overlapping layers of tissue.
 31. The device of claim 30, wherein said first end is embedded in, and does not extend through, septum secundum.
 32. The device of claim 31, wherein said first end is formed into a coil, hook, corkscrew, or other anchor.
 33. The device of claim 30, wherein said first end includes a material selected from the group consisting of bioresorbable materials, noble metals, shape memory materials, metals, polymeric materials, and swellable foams.
 34. The device of claim 33, wherein said shape memory material includes nitinol.
 35. The device of claim 30, wherein said first end includes a septal puncture needle capable of puncturing mammalian tissue.
 36. The device of claim 30, further comprising a catheter containing said device in an elongated, low-profile form, said first end being expandable to form an anchor and said second end being adjustable to alter a compressive force applied to the overlapping layers of tissue.
 37. The device of claim 30, wherein said device is sized and shaped to further extend to septum secundum in the right atrium.
 38. The device of claim 37, wherein said device includes a ring with a gap terminating in first and second opposed, pointed ends for puncturing mammalian tissue.
 39. The device of claim 38, wherein said device includes a material selected from the group consisting of flexible polymers, bioabsorbable materials, spring metals, and shape memory materials.
 40. The device of claim 39, wherein said device includes nitinol.
 41. The device of claim 38, wherein said device consists essentially of a monolithic partial ring.

42. The device of claim 38, wherein said device includes a gap slightly smaller than the thickness of the overlapping layers of tissue to which it is connected.
43. The device of claim 38, wherein said device includes a gap slightly smaller than the thickness of septum secundum.
44. The device of claim 38, wherein said first and second ends overlap each other.
45. The device of claim 30, wherein said device includes a partial ring with first and second ends and at least one fold therebetween.
46. The device of claim 45, wherein said at least one fold cooperates with said first and second ends to apply a compressive force to said overlapping layers of tissue.
47. The device of claim 45, wherein said device consists essentially of a monolithic partial ring.
48. The device of claim 30, wherein said device is sized and shaped to further contact the surfaces of septum primum exposed in both the left and right atria.
49. A method of closing two overlapping layers of tissue in a mammalian heart, comprising:
 - (a) inserting into a right atrium of said heart a closure device including a grappling hook member joined to at least two curved arms by an enlarged-tip joinder member, said grappling hook member including at least two grappling hooks capable of being reversibly and distally elongated along a lengthwise axis;
 - (b) puncturing septum primum and passing a portion of said closure device through septum primum and into a left atrium of said heart;
 - (c) deploying said grappling hook member into the left atrium such that said grappling hooks are embedded into the surfaces of septum primum and septum secundum exposed in the left atrium;
 - (d) drawing together septum primum and septum secundum; and
 - (e) deploying said curved arms such that said curved arms engage the surfaces of septum primum and septum secundum exposed in the right atrium to compress septum primum and septum secundum and close the overlapping layers of tissue.
50. The method of claim 49, wherein said grappling hook member and said curved arms include a shape memory material.
51. The method of claim 50, wherein said grappling hook member and said curved arms include nitinol.

52. A device for closing two overlapping layers of tissue in a mammalian heart, comprising a grappling hook member joined to at least one curved arm by an enlarged-tip joiner member, wherein said grappling hook member includes at least one grappling hook capable of being reversibly and distally elongated along a lengthwise axis.
53. The device of claim 52, further comprising an elongate tether connected to said joiner member.
54. The device of claim 52, wherein said grappling hook member and said at least one curved arm include a shape memory material.
55. The device of claim 54, wherein said grappling hook member and said at least one curved arm include nitinol.
56. The device of claim 52, further comprising a catheter containing said device.
57. The device of claim 52, wherein said overlapping layers of tissue constitute a patent foramen ovale (PFO).
58. A method of closing two overlapping layers of tissue in a mammalian heart, comprising:
- (a) inserting a catheter into a right atrium of said heart, said catheter containing a closure device consisting essentially of first and second opposed grappling hook members and a central connecting member, wherein each of said grappling hook members includes at least two curved grappling hooks capable of being reversibly and distally elongated so as to lie along the longitudinal axis of said connecting member;
 - (b) inserting said catheter between the overlapping layers of tissue and into a left atrium of said heart;
 - (c) deploying said first grappling hook member into the left atrium;
 - (d) retracting said catheter into the right atrium, such that said grappling hooks of said first grappling hook member are embedded into the surfaces of septum primum and septum secundum exposed in the left atrium and said connecting member extends at an angle between septum primum and septum secundum, thereby drawing together septum primum and septum secundum and closing said overlapping layers of tissue; and
 - (e) further retracting said catheter out of the right atrium, such that said second grappling hook member is deployed and said grappling hooks of said second grappling hook member are embedded into the surfaces of septum primum and septum secundum exposed in the right atrium.

59. The method of claim 58, wherein said closure device includes a material selected from the group consisting of bioabsorbable materials, spring metals, shape memory materials, and flexible polymer materials.
60. The method of claim 59, wherein said closure device includes nitinol.
61. A method for closing two overlapping layers of tissue in a mammalian heart, comprising inserting a closure device into said heart, said closure device consisting essentially of first and second opposed grappling hook members and a central connecting member, wherein said grappling hook members, when deployed, compress septum primum and septum secundum, thereby closing said overlapping layers of tissue.
62. The method of claim 61, wherein said closure device includes a material selected from the group consisting of bioresorbable materials, spring metals, shape memory materials, and flexible polymer materials.
63. The method of claim 62, wherein said closure device includes nitinol.
64. A device for closing two overlapping layers of tissue in a mammalian heart, consisting essentially of first and second opposed grappling hook members and a central connecting member, wherein each of said grappling hook members includes at least two curved grappling hooks capable of being reversibly and distally elongated so as to lie along the longitudinal axis of said connecting member.
65. The device of claim 64, wherein said device includes a material selected from the group consisting of bioabsorbable materials, spring metals, shape memory materials, and flexible polymer materials.
66. The device of claim 65, wherein said device includes nitinol.
67. The device of claim 64, wherein said overlapping layers of tissue constitute a patent foramen ovale (PFO).
68. A device for closing a patent foramen ovale (PFO) in a mammalian heart, consisting essentially of a first grappling hook member including at least two proximally-curved grappling hooks, and a central connecting member, wherein said grappling hook member is capable of being reversibly and distally elongated so as to lie along the longitudinal axis of said connecting member.
69. The device of claim 68, wherein said device includes a material selected from the group consisting of spring metals and shape memory materials.
70. The device of claim 69, wherein said device includes nitinol.

71. A method of closing two overlapping layers of tissue in a mammalian heart, comprising:

- (a) inserting a septal needle catheter into a right atrium of said heart, said catheter containing at least one closure device having first and second ends, wherein said first end of said closure device is a closure device anchor;
- (b) puncturing septum secundum and then septum primum with said septal needle catheter such that said catheter enters a left atrium of said heart,
- (c) deploying said first end of said closure device into the left atrium,
- (d) retracting said catheter through septum primum and then septum secundum, whereby said first end of said closure device is pulled against the surfaces of septum primum and septum secundum exposed in the left atrium;
- (e) further retracting said catheter out of the right atrium, such that said second end is deployed in the right atrium; and
- (f) forming said second end of said closure device into a structure having a diameter larger than that of said catheter such that said second end is maintained in the right atrium, thereby drawing septum primum and septum secundum together and closing said overlapping layers of tissue.

72. The method of claim 71, wherein said closure device anchor includes a material selected from the group consisting of bioabsorbable polymers, metals, and shape memory materials.

73. The method of claim 72, wherein said closure device anchor includes nitinol.

74. The method of claim 71, wherein said closure device anchor is of a shape selected from the group consisting of discs and hooks.

75. The method of claim 71, wherein said second end of said closure device is formed into a knot, coil, spiral, or other adjustable mechanism sufficient to hold the closure device in place.

76. The method of claim 71, wherein said second end of said closure device is formed into a structure capable of being adjusted to alter the level of compression applied to the overlapping layers of tissue.

77. The method of claim 71, wherein said catheter contains multiple closure devices and steps (a) through (f) are repeated at least once.

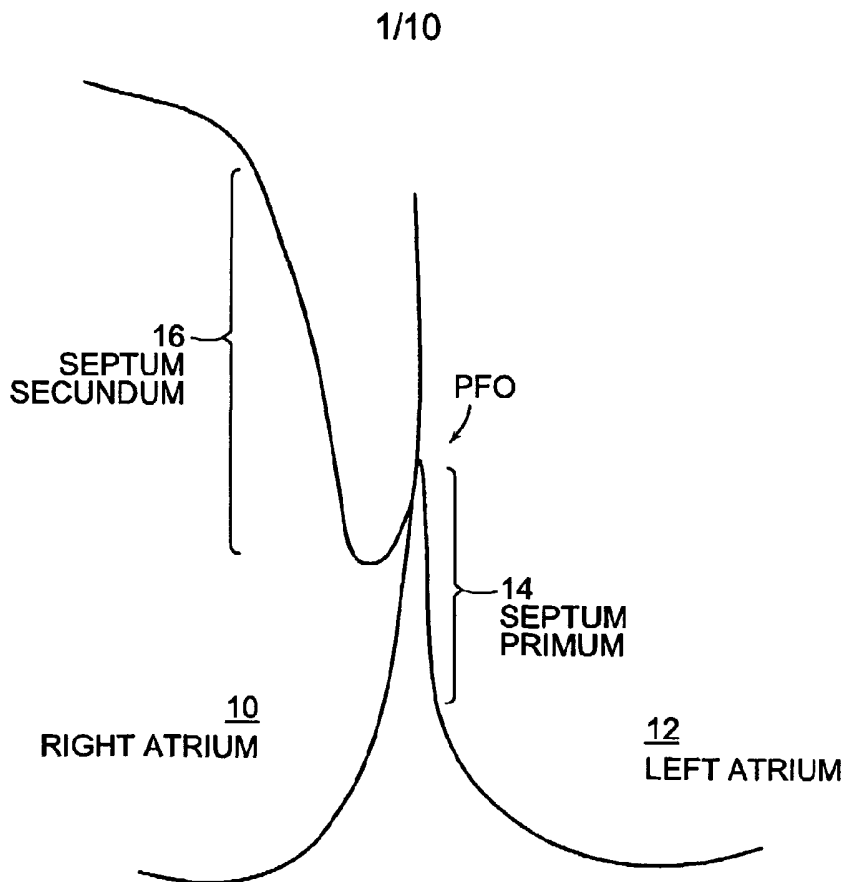

FIG. 1
PRIOR ART

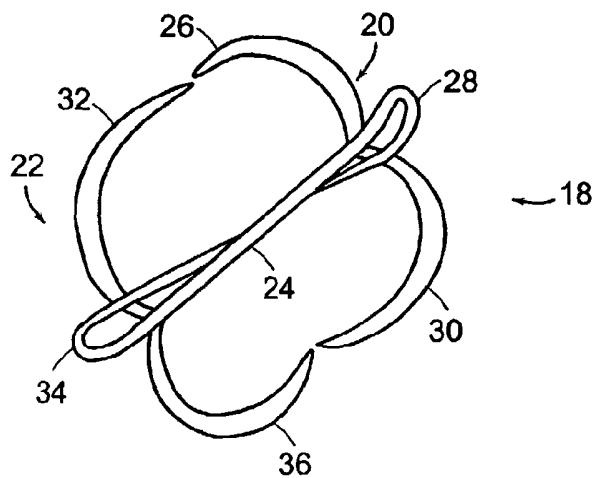

FIG. 2

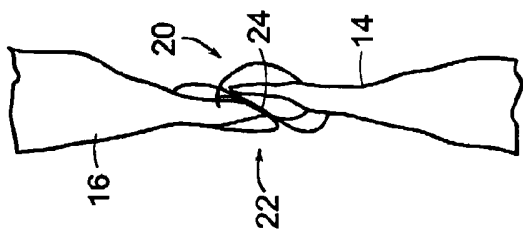

FIG. 3C

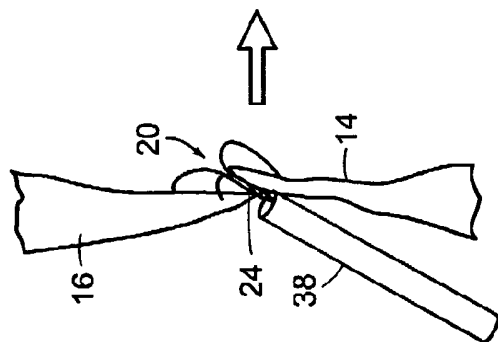

FIG. 3B

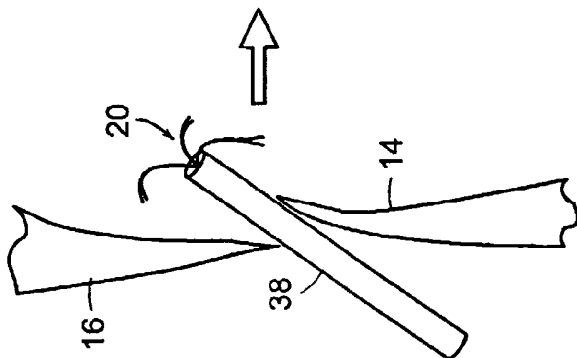

FIG. 3A

3/10

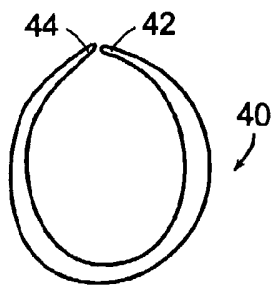

FIG. 4

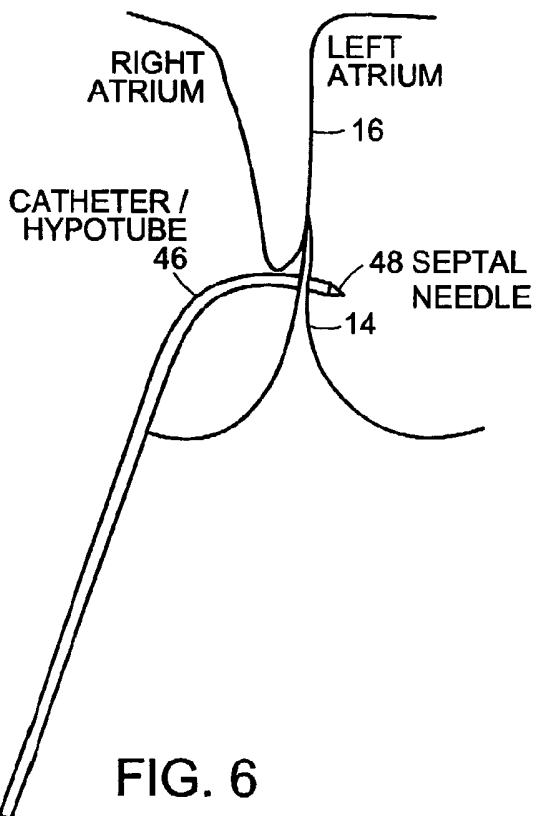

FIG. 6

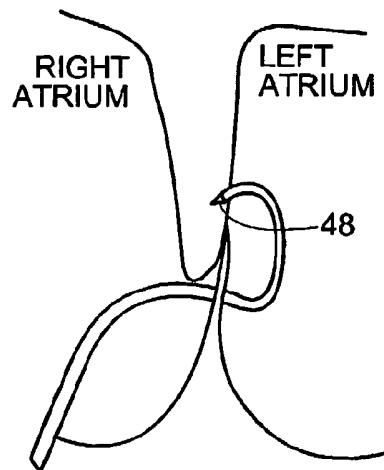

FIG. 7

4/10

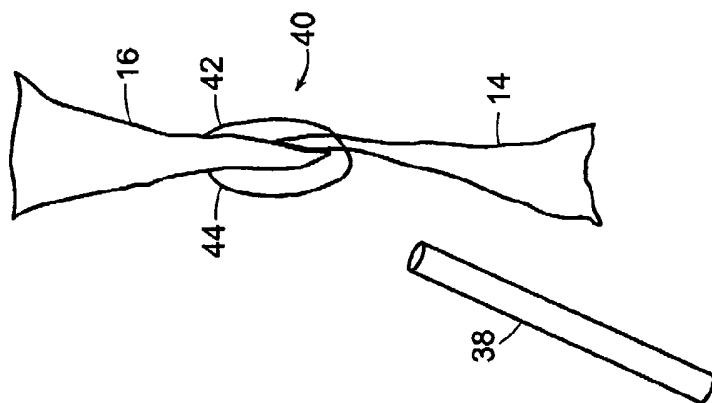

FIG. 5C

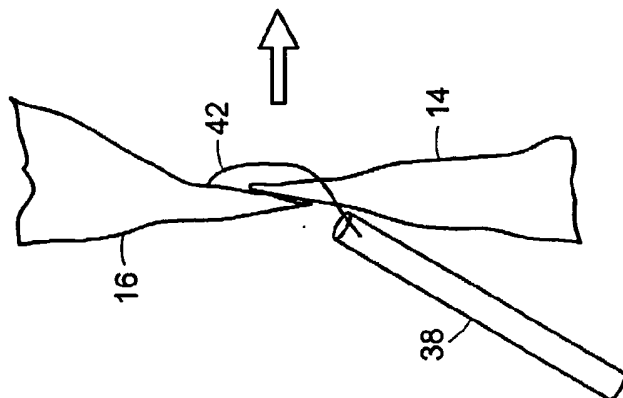

FIG. 5B

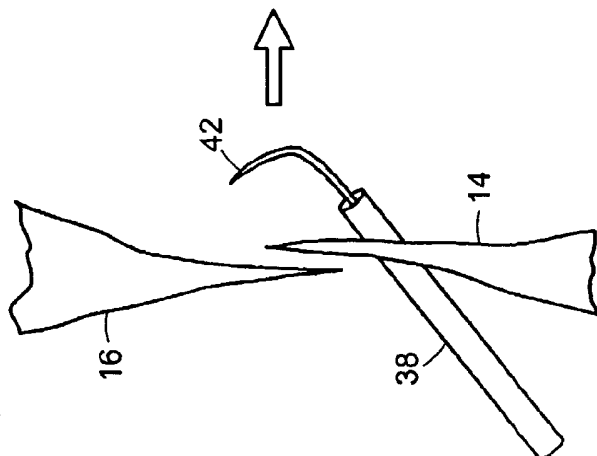

FIG. 5A

5/10

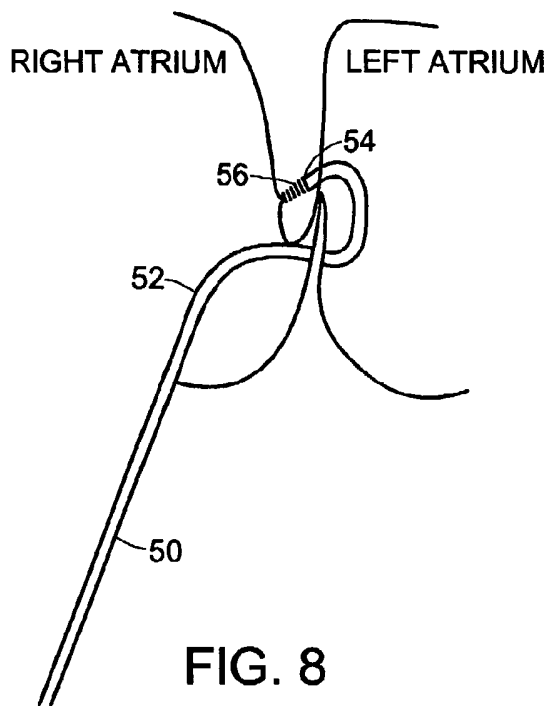

FIG. 8

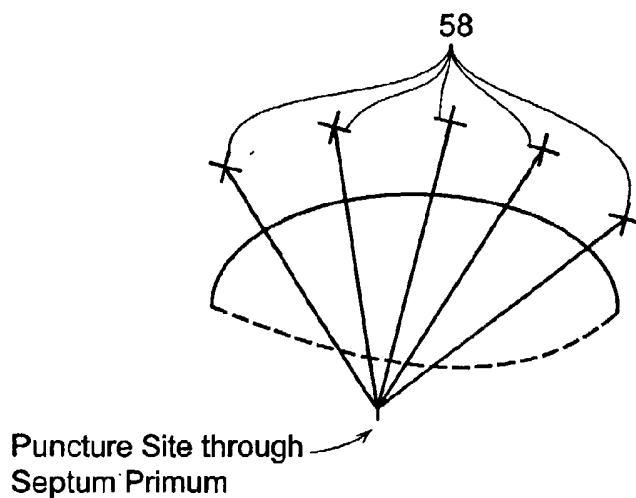

FIG. 9

6/10

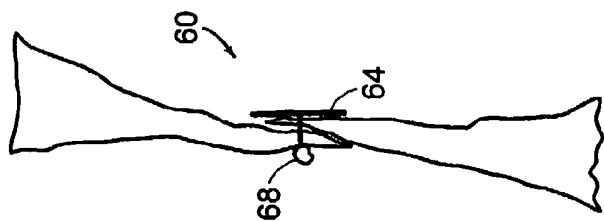

FIG. 10C

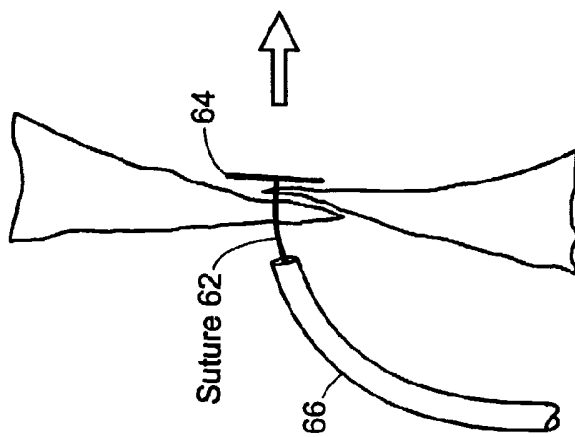

FIG. 10B

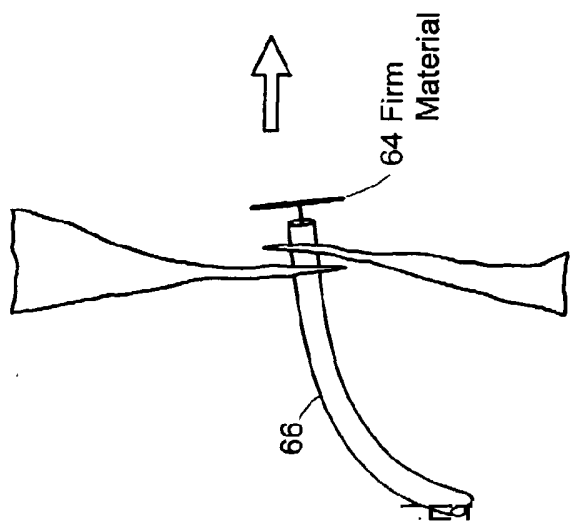

FIG. 10A

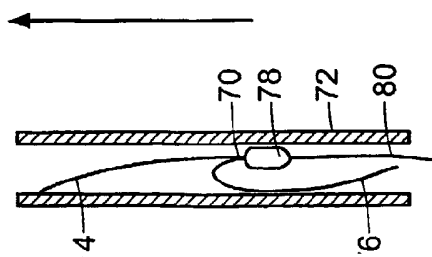

FIG. 11A

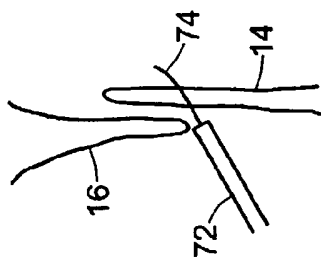

FIG. 11B

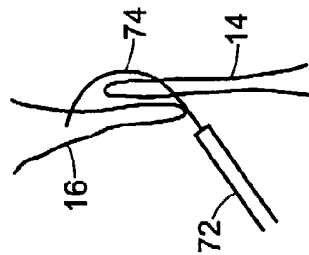

FIG. 11C

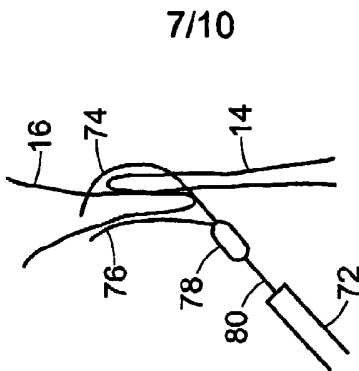

FIG. 11D

7/10

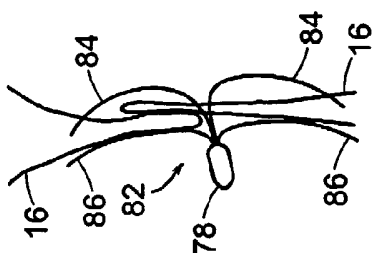

FIG. 12C

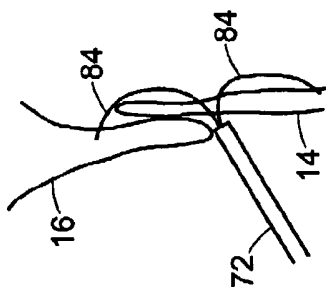

FIG. 12B

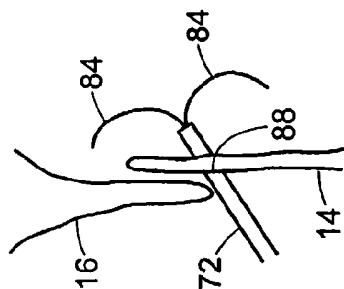

FIG. 12A

9/10

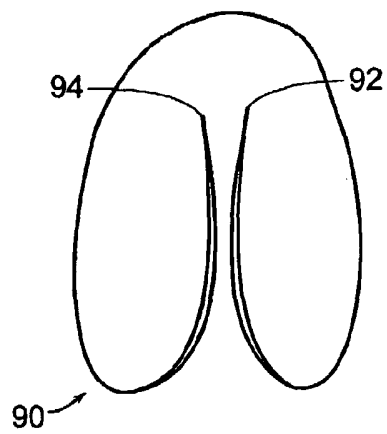

FIG. 13

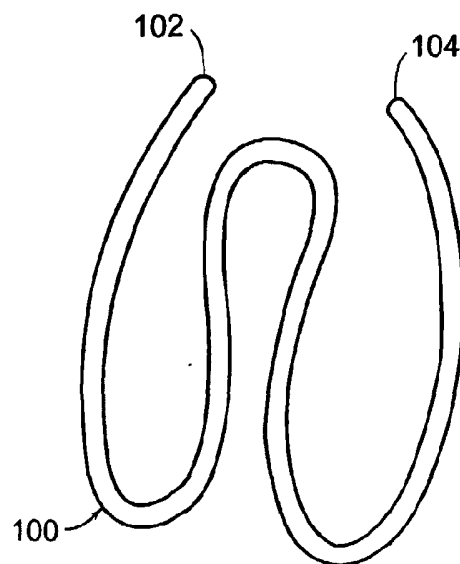

FIG. 14

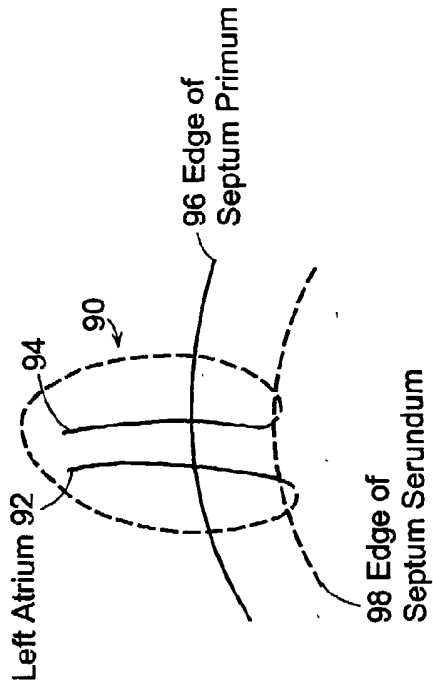

FIG. 15A

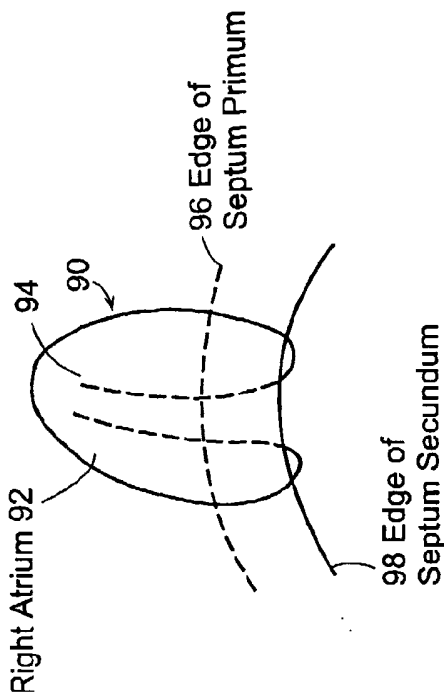

FIG. 15B

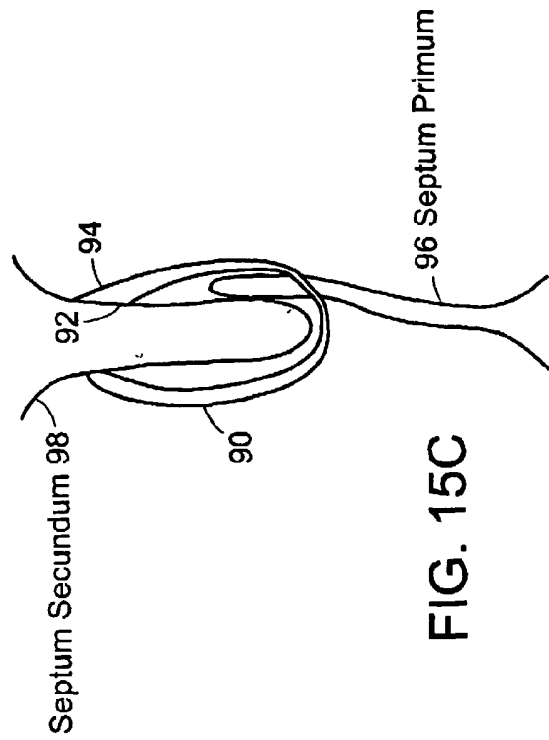

FIG. 15C