



(19) **United States**

(12) **Patent Application Publication**
Jones et al.

(10) **Pub. No.: US 2015/0283531 A1**

(43) **Pub. Date: Oct. 8, 2015**

(54) **MICROSPOTTING DEVICE**

Publication Classification

(71) Applicant: **BioFire Diagnostics, LLC**, Salt Lake City, UT (US)

(51) **Int. Cl.**
B01J 19/00 (2006.01)

(72) Inventors: **David E. Jones**, Layton, UT (US); **Kirk Max Ririe**, Salt Lake City, UT (US); **Thomas Charles Robbins**, Salt Lake City, UT (US); **Elizabeth Doman Copene**, Salt Lake City, UT (US); **Charles Benjamin Cox**, Sandy, UT (US)

(52) **U.S. Cl.**
CPC **B01J 19/0046** (2013.01); **B01J 2219/00355** (2013.01); **B01J 2219/00585** (2013.01); **B01J 2219/00385** (2013.01); **B01J 2219/00376** (2013.01); **B01J 2219/00313** (2013.01)

(57) **ABSTRACT**

Devices and methods are provided for spotting an array with fluid. Arrays produced by such methods are also provided. In one aspect of the invention, a spotter device for spotting a plurality of fluids into an array is described, the spotter device comprising a plurality of reservoirs provided in a first configuration, each reservoir holding its respective fluid, a print head having a plurality of positions provided in a second configuration, the second configuration being different from the first configuration, a plurality of tubes, each tube configured to provide fluid communication from a reservoir at a first end of the tube to a position in the print head at the second end of the tube, and a pump for pumping fluid through the tubes from the reservoir to the print head.

(21) Appl. No.: **14/395,002**

(22) PCT Filed: **Apr. 17, 2013**

(86) PCT No.: **PCT/US13/36939**

§ 371 (c)(1),

(2) Date: **Oct. 16, 2014**

Related U.S. Application Data

(60) Provisional application No. 61/625,849, filed on Apr. 18, 2012.

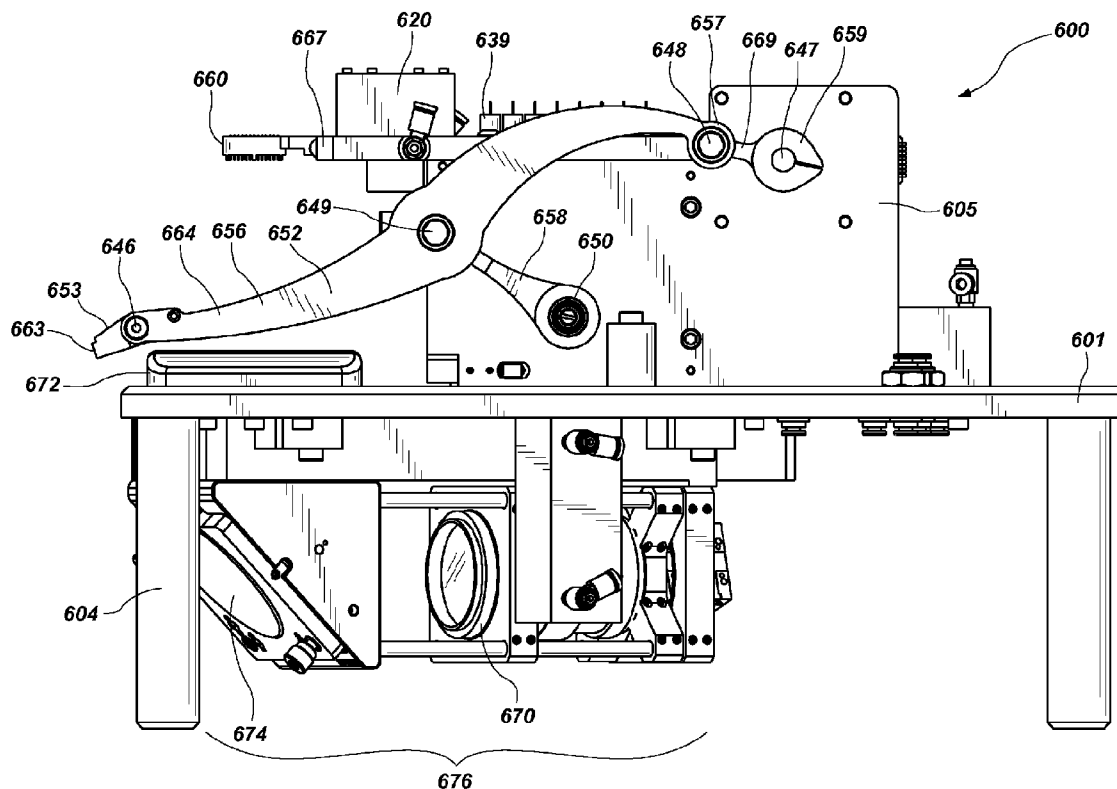

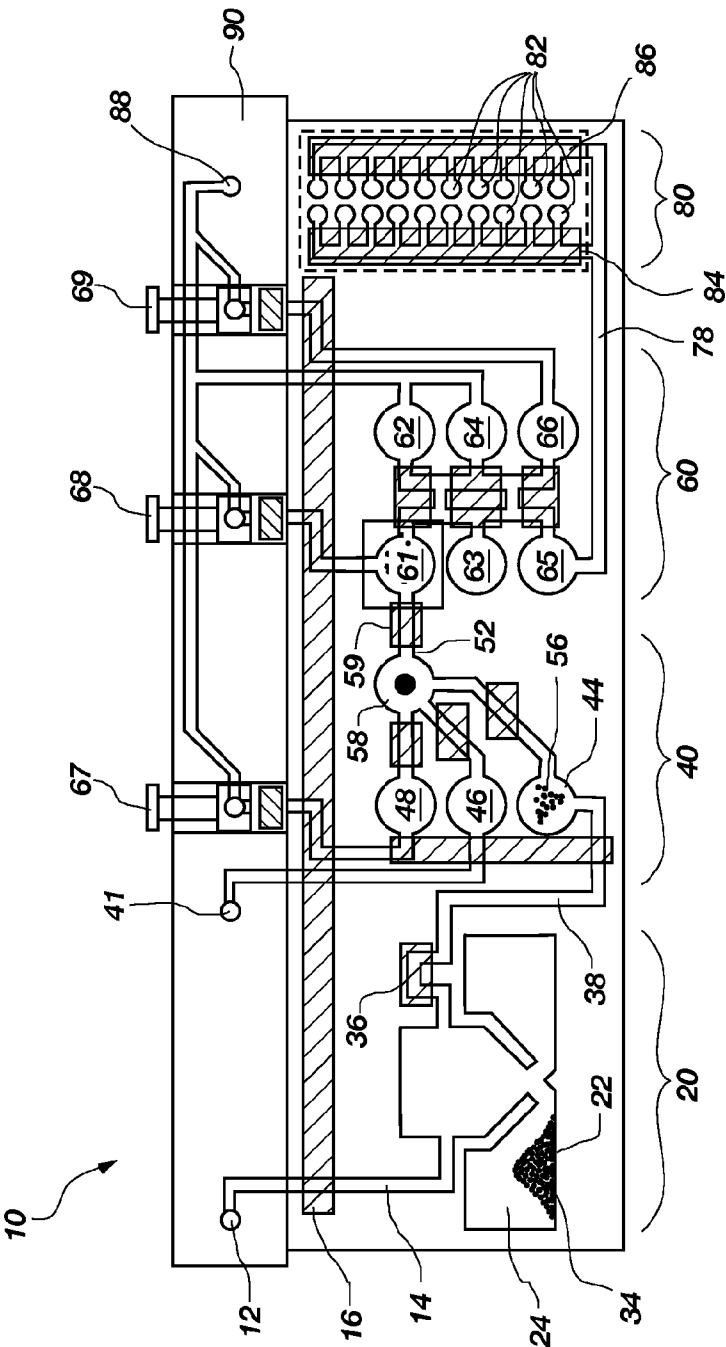

FIG. 1

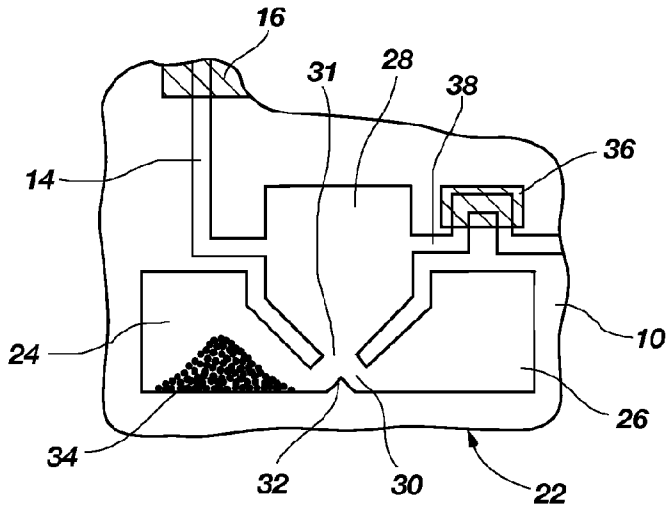

FIG. 2

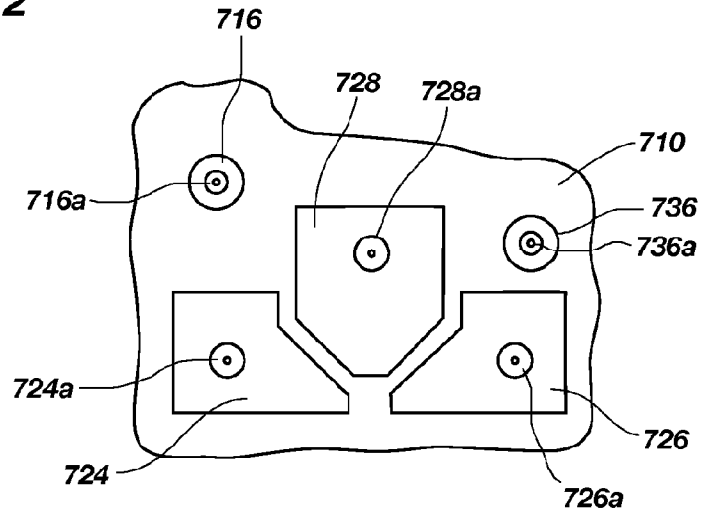

FIG. 2a

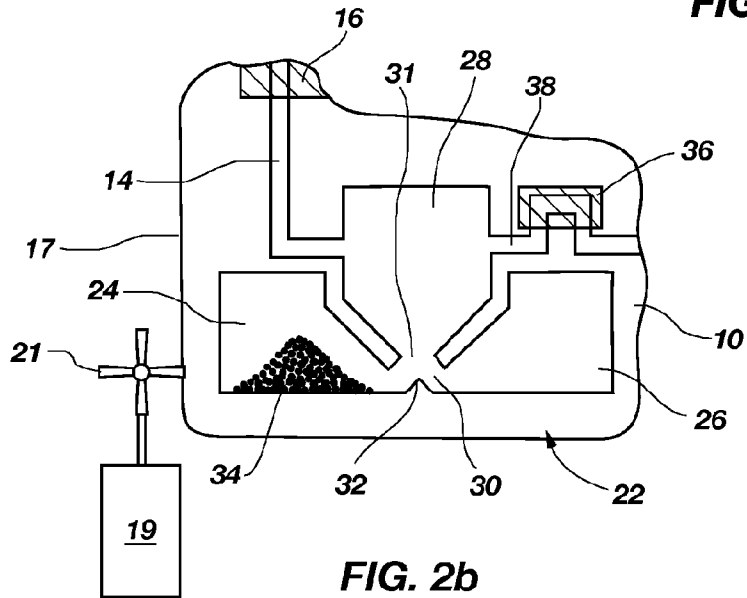

FIG. 2b

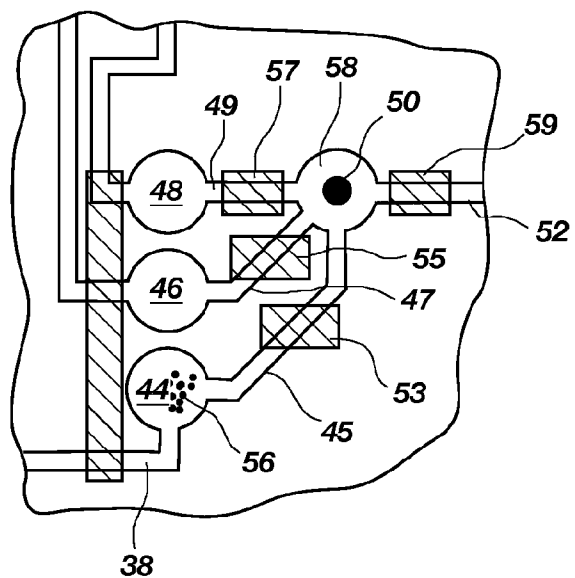

FIG. 3

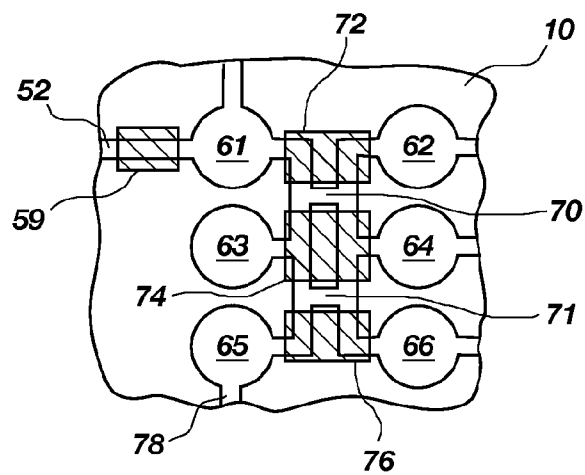

FIG. 4

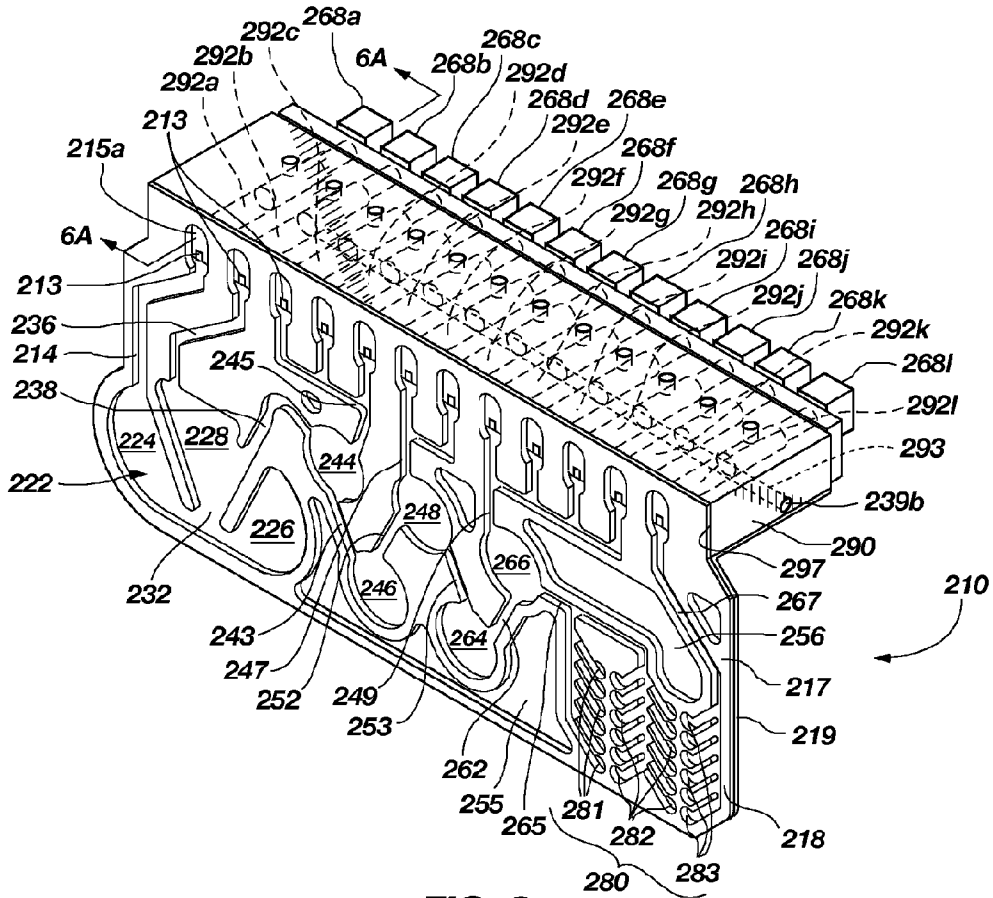

FIG. 6

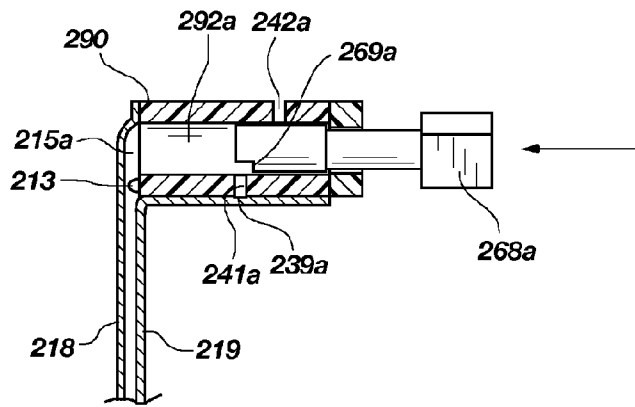

FIG. 6a

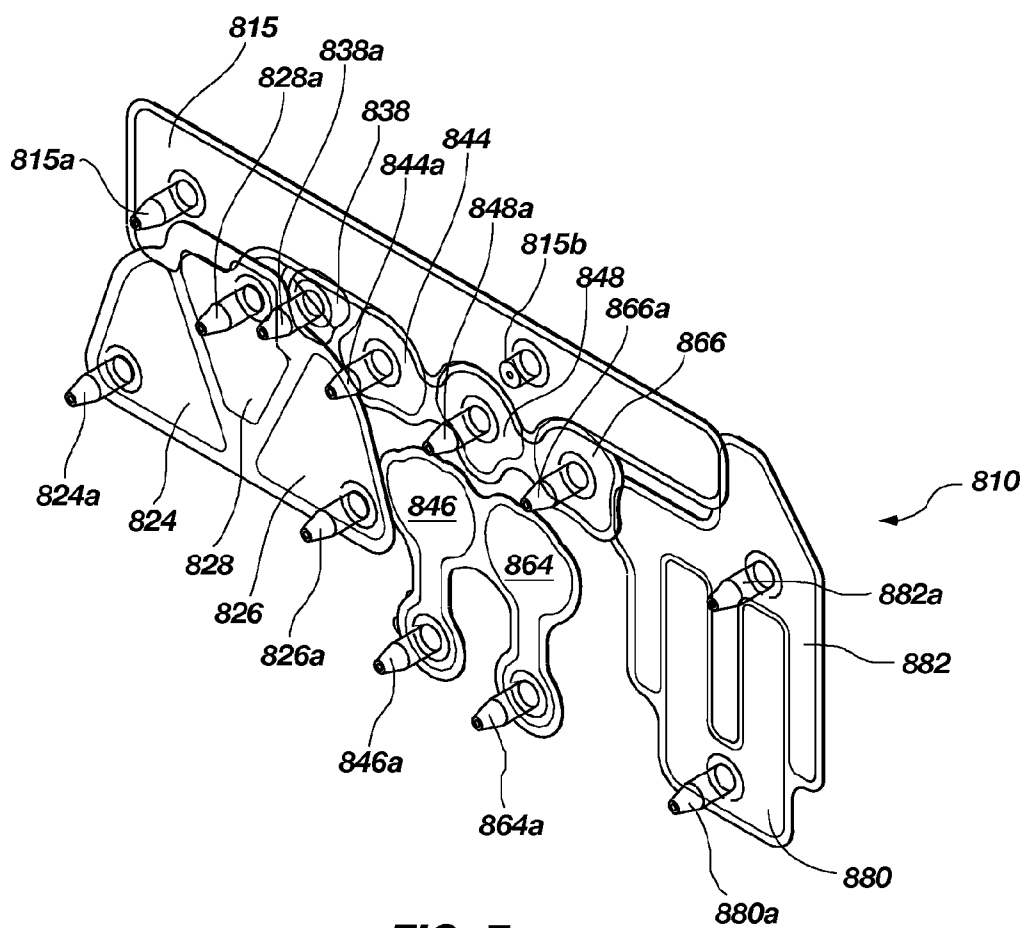

FIG. 7

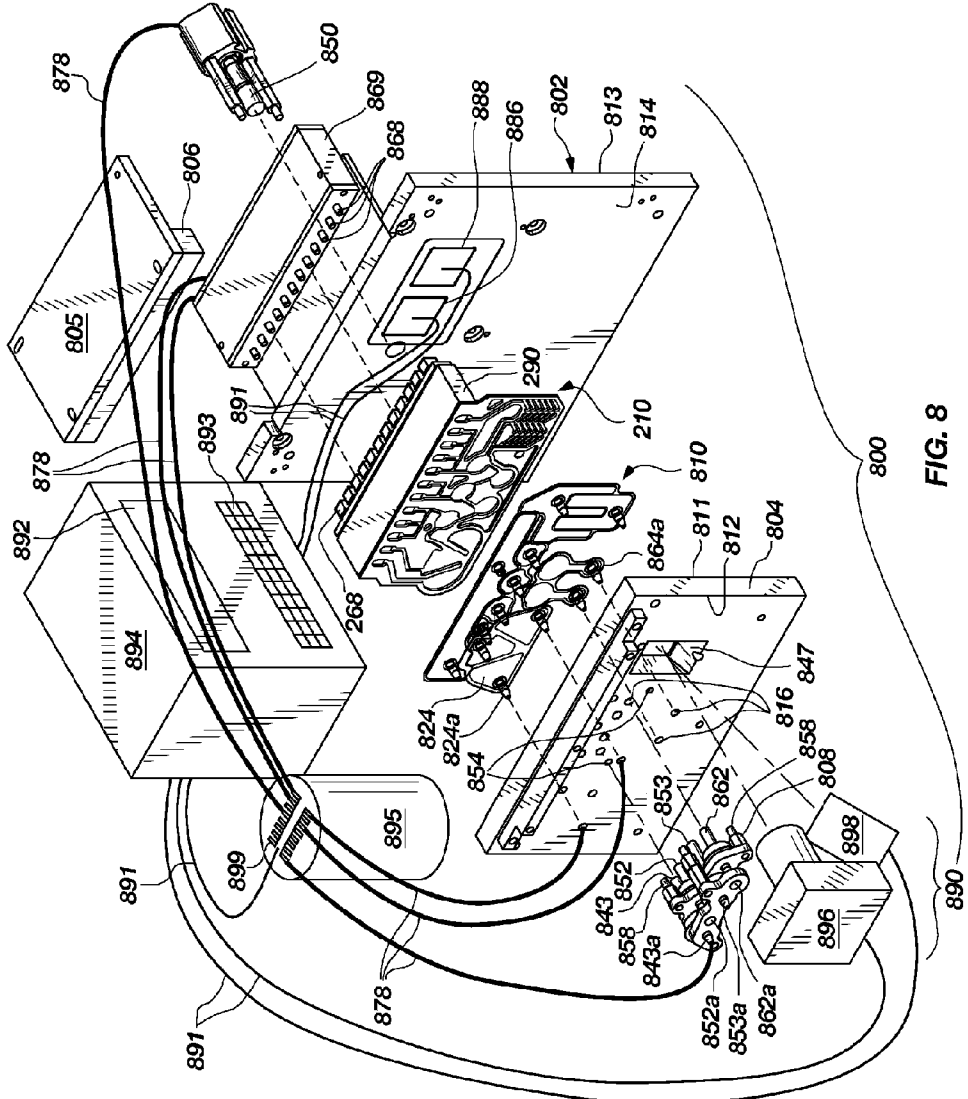

FIG. 8

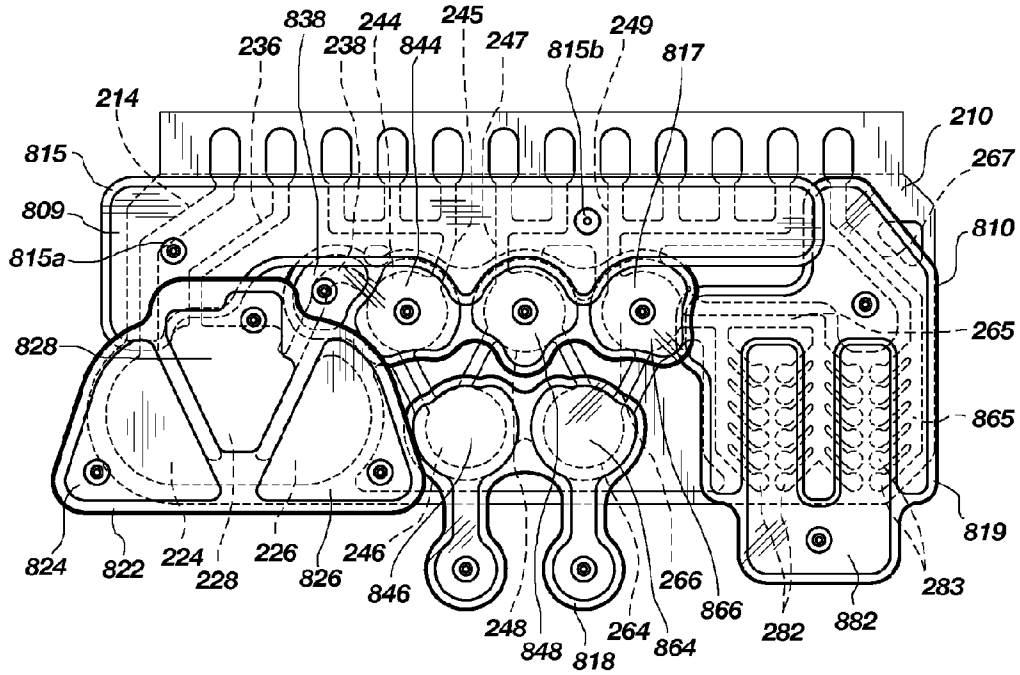

FIG. 9

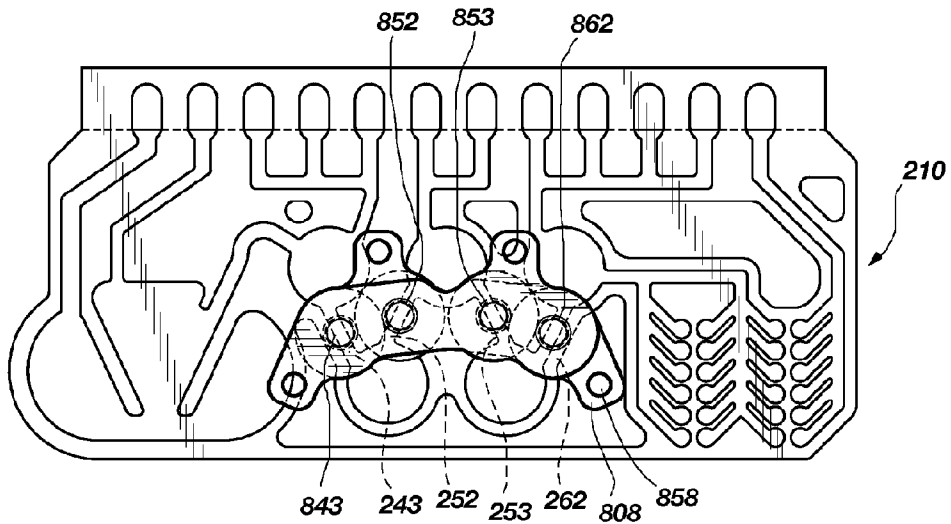

FIG. 10

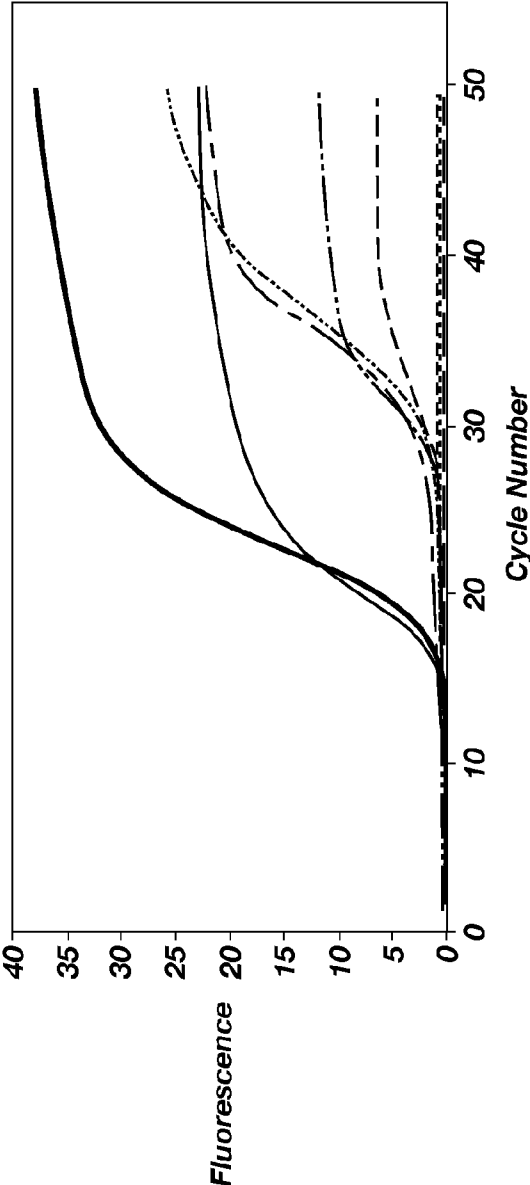

FIG. 11

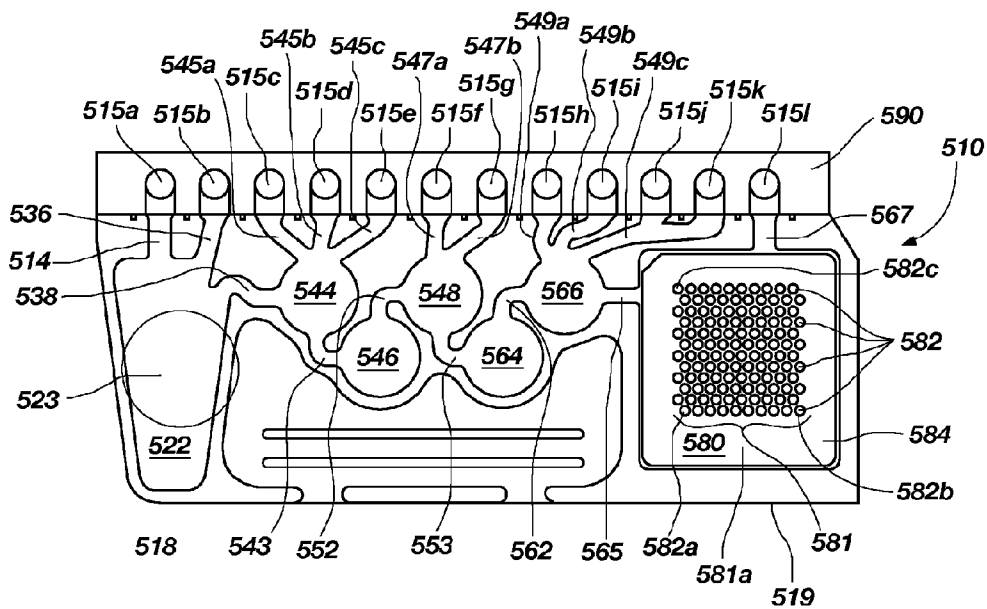

FIG. 12

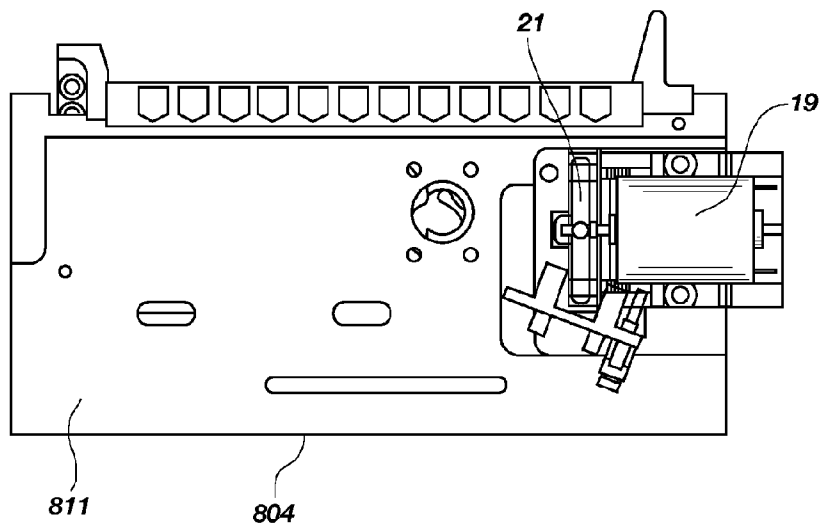

FIG. 13

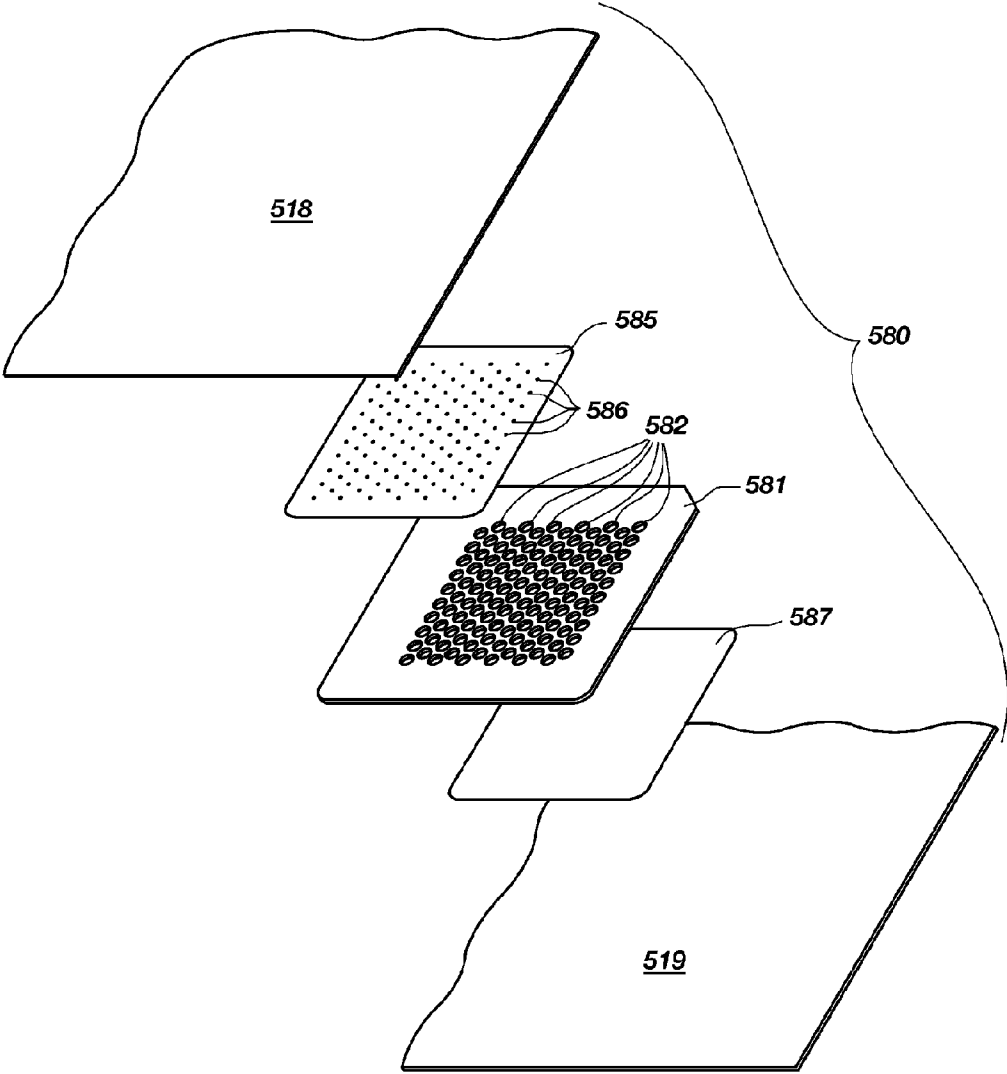

FIG. 14

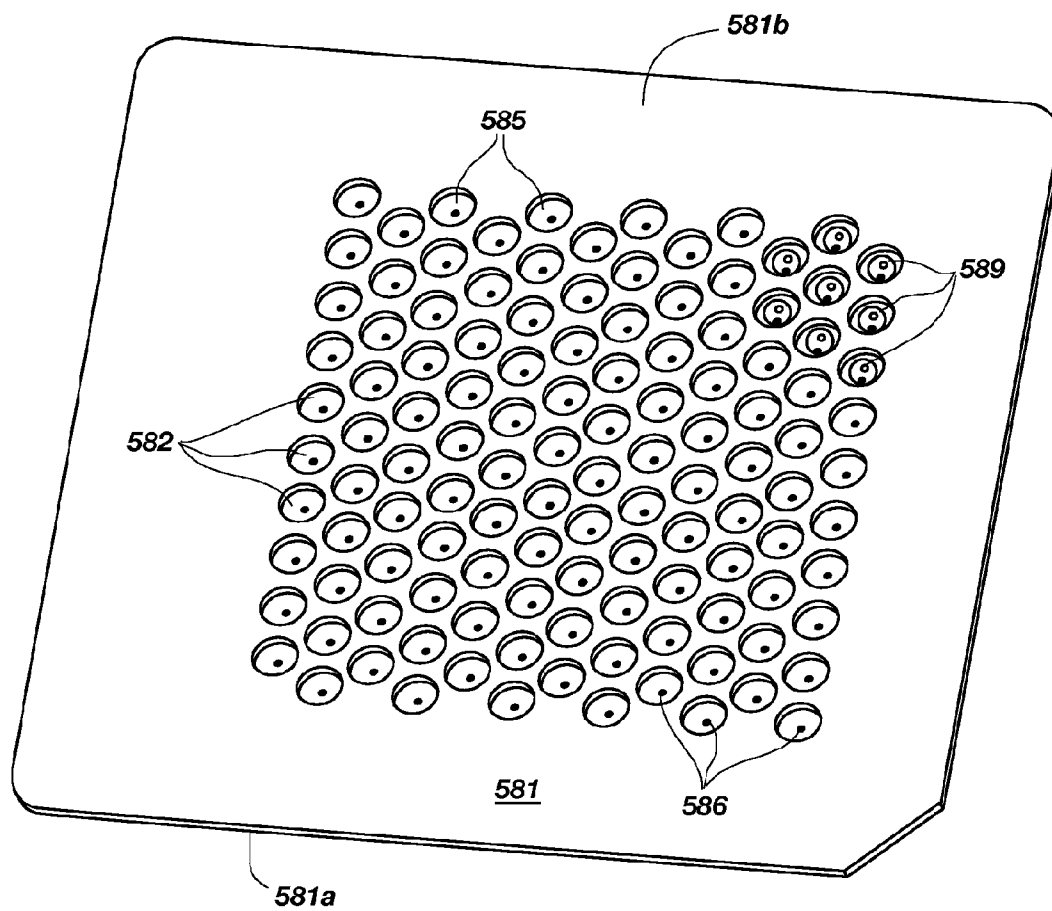

FIG. 15

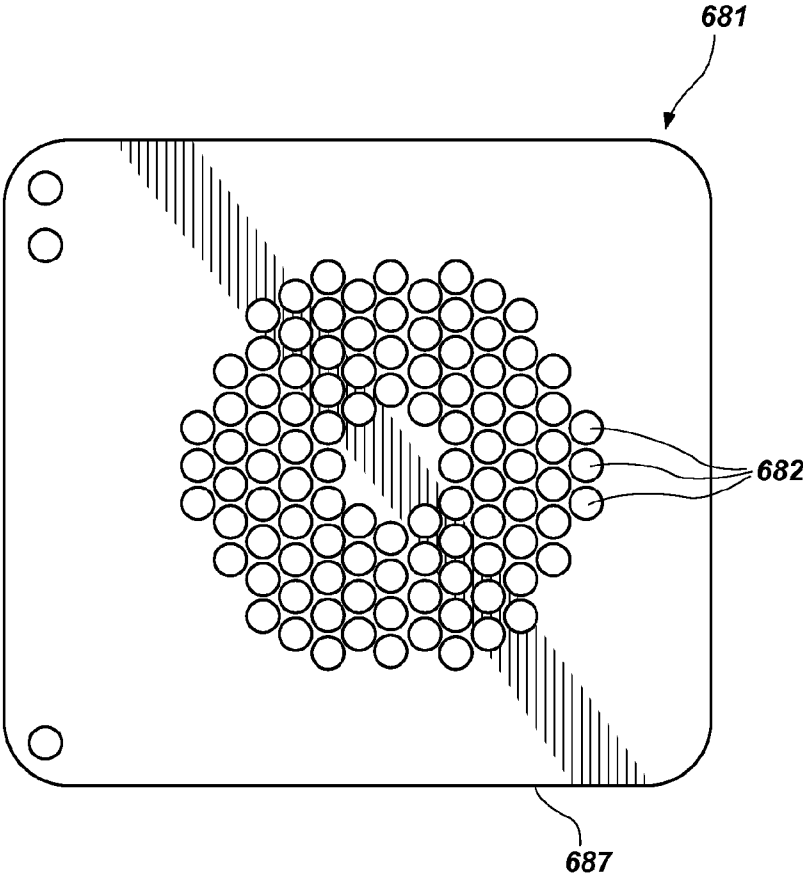

FIG. 16

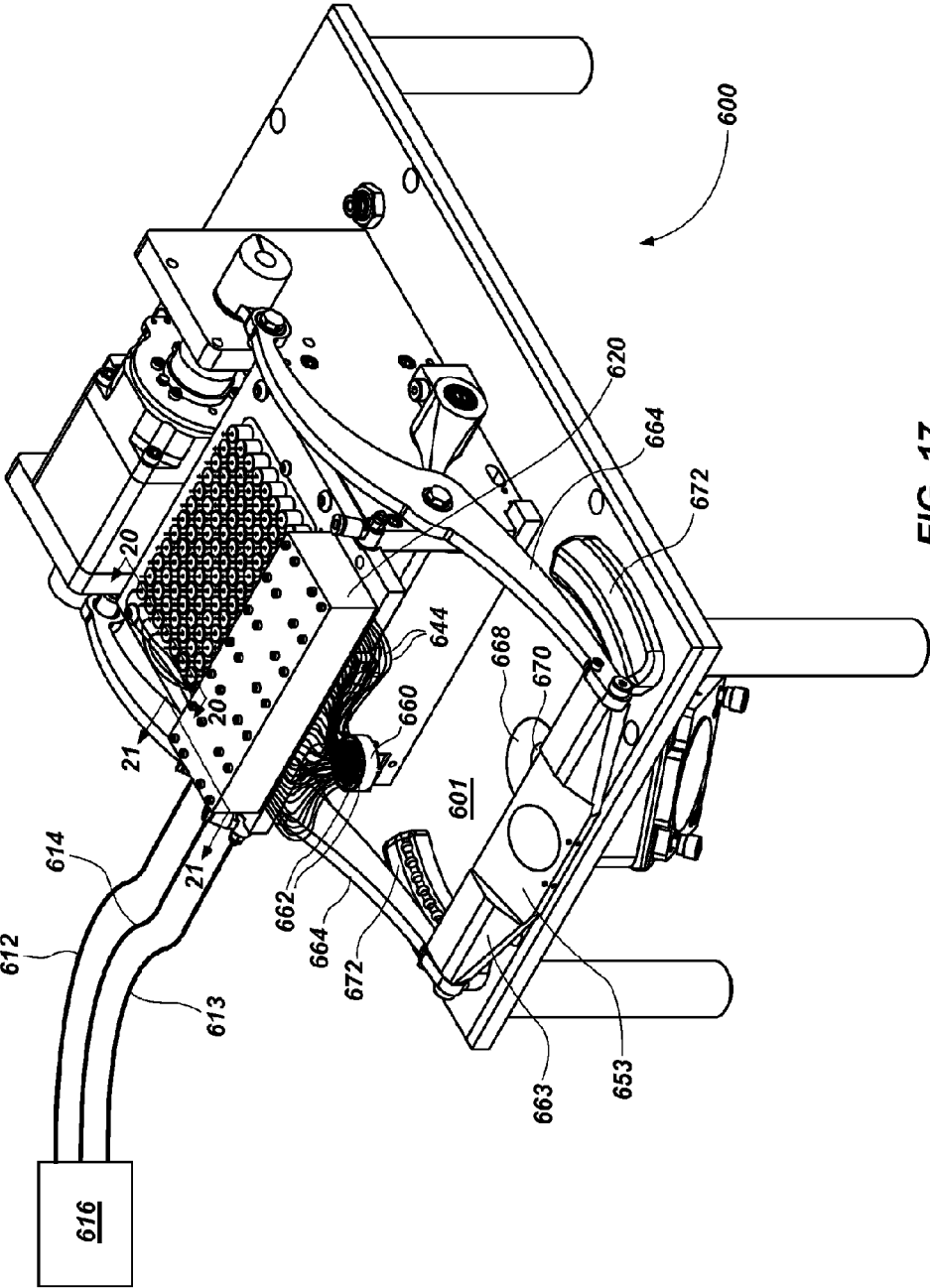

FIG. 17

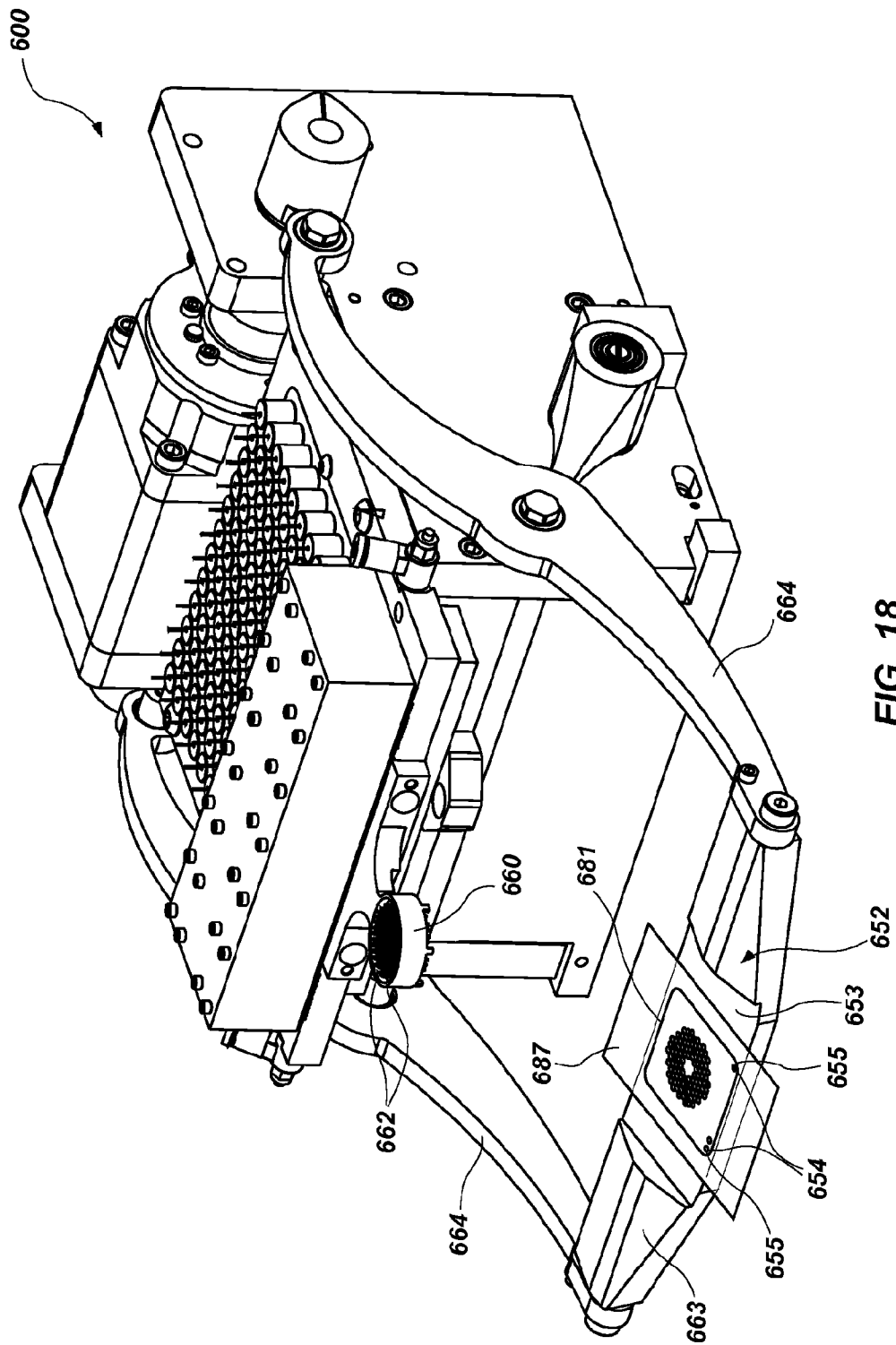

FIG. 18

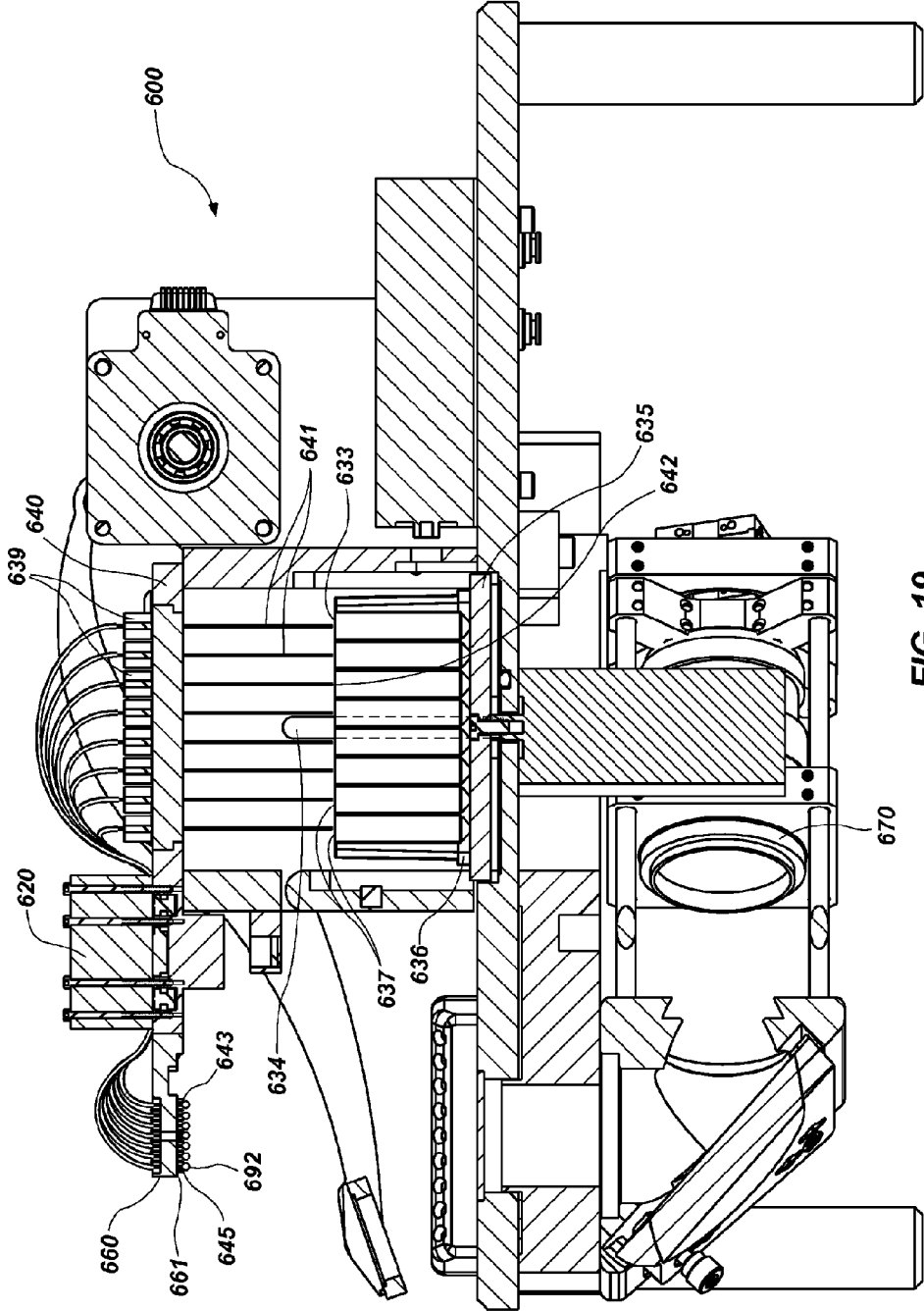

FIG. 19

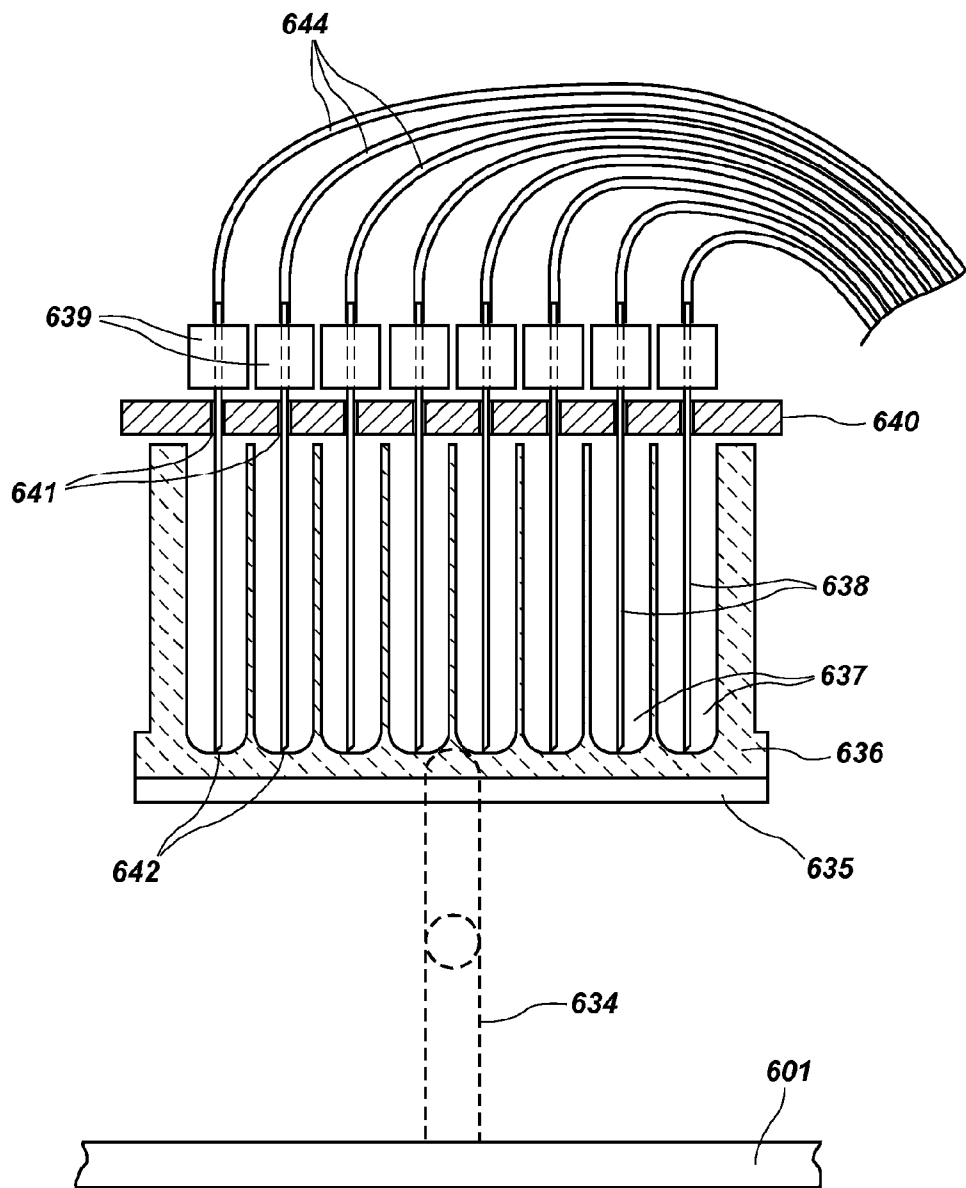

FIG. 20

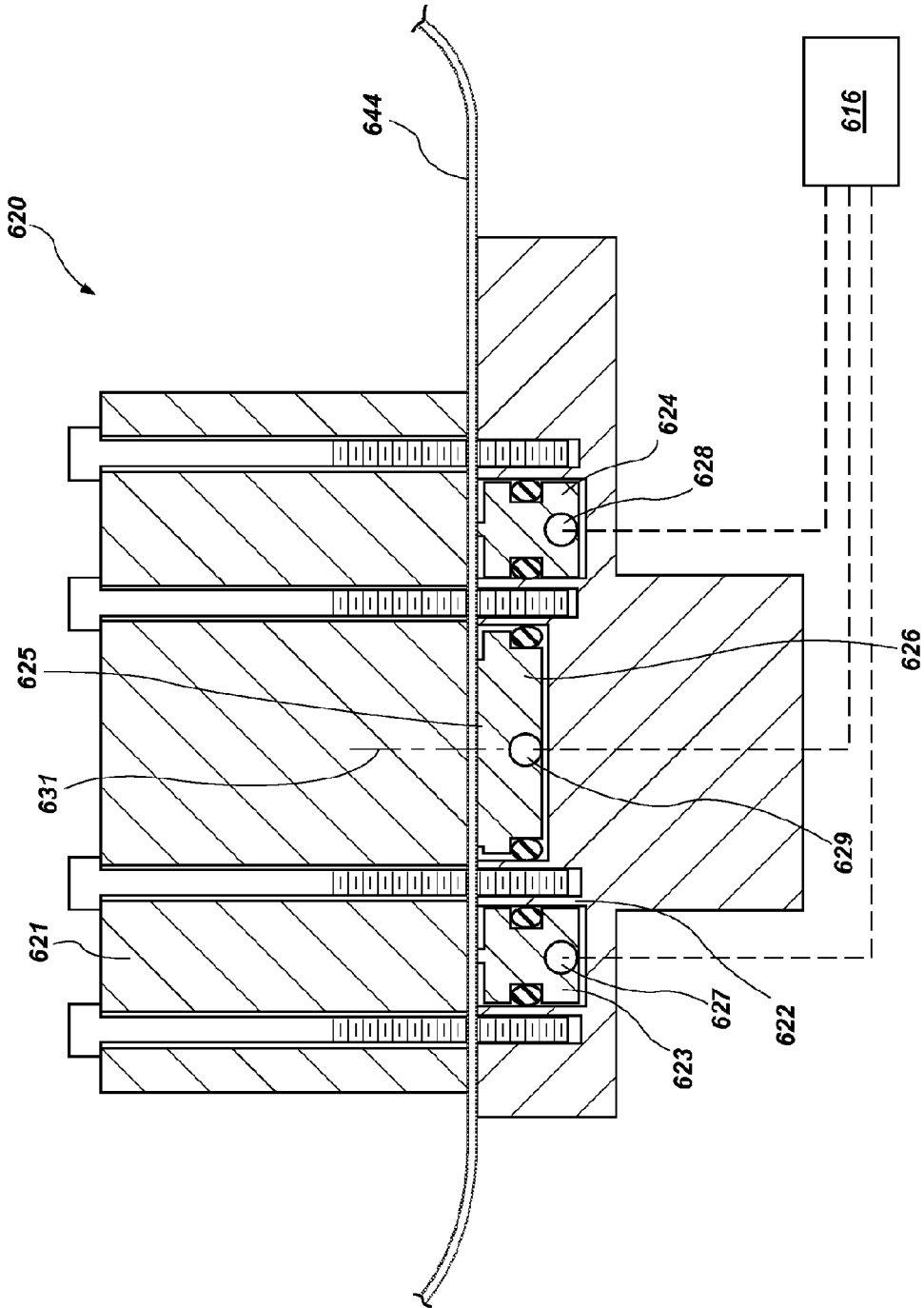

FIG. 21

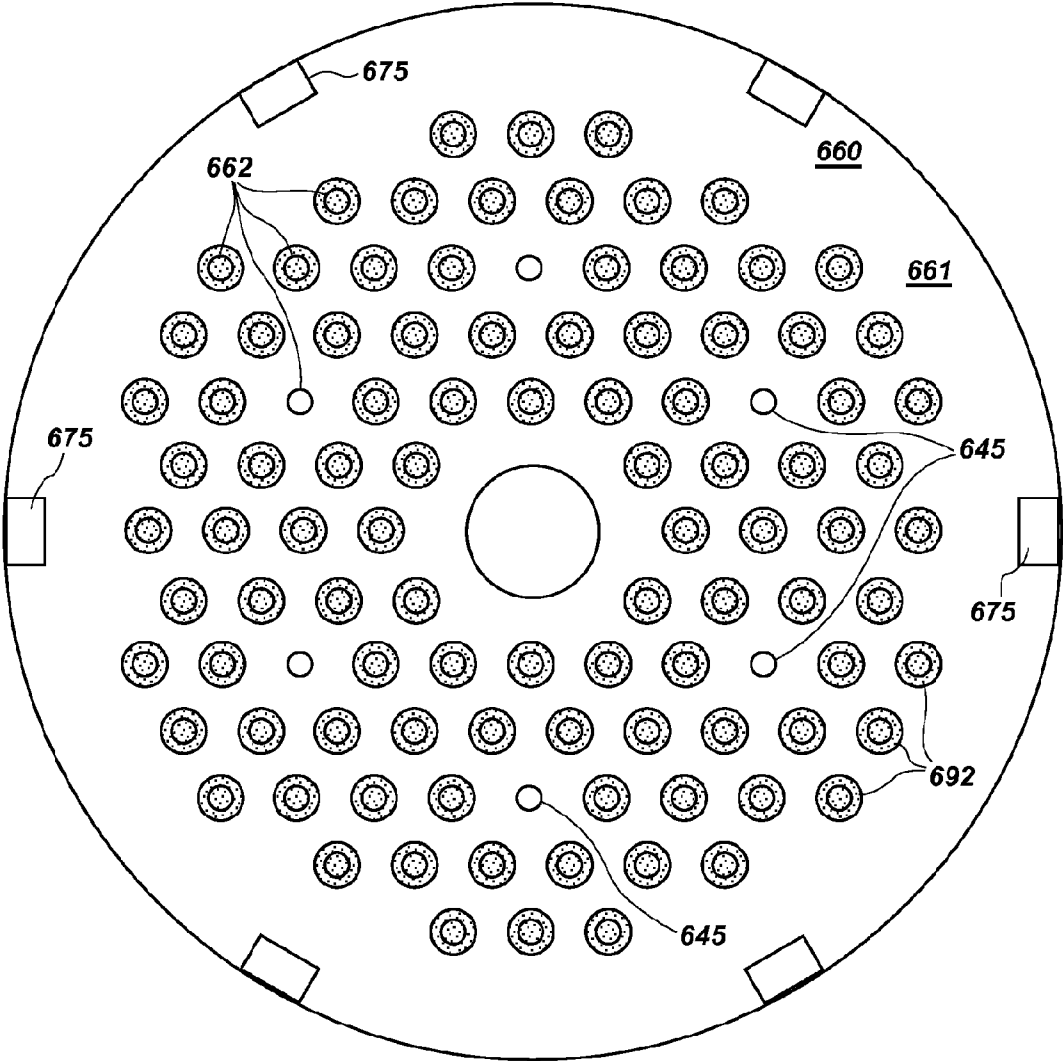

FIG. 22

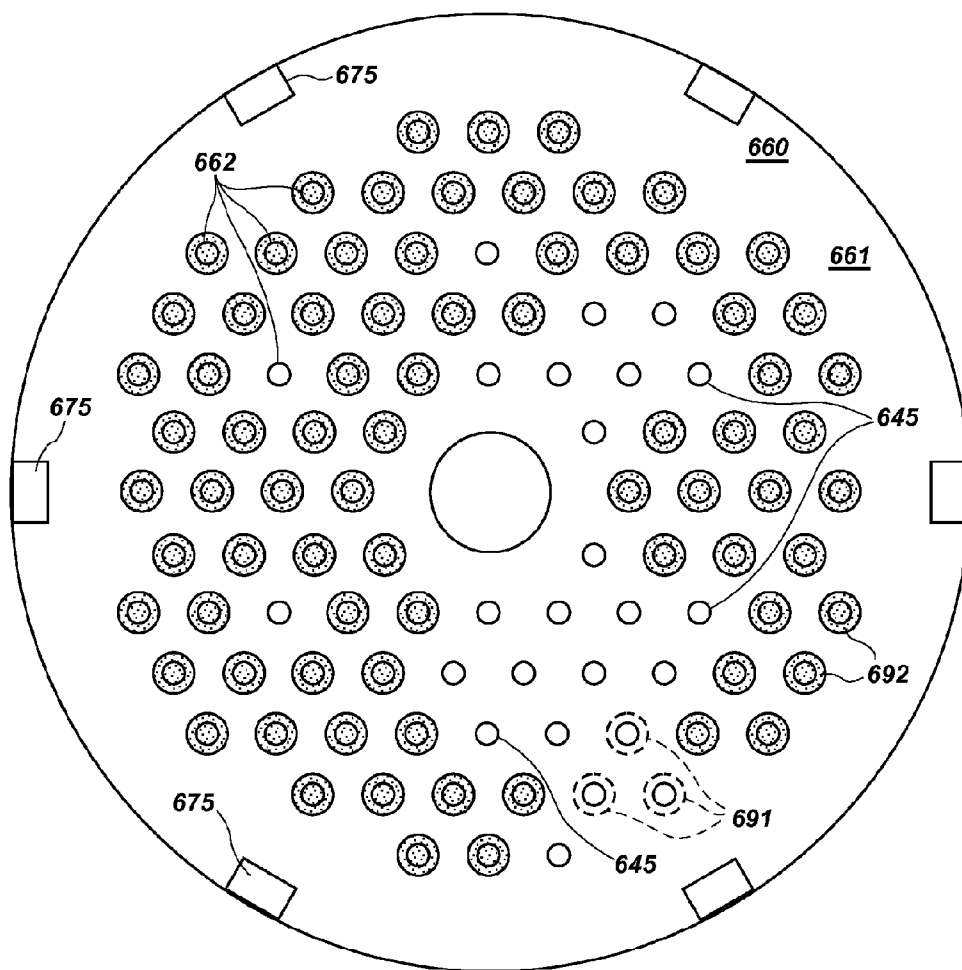

FIG. 23

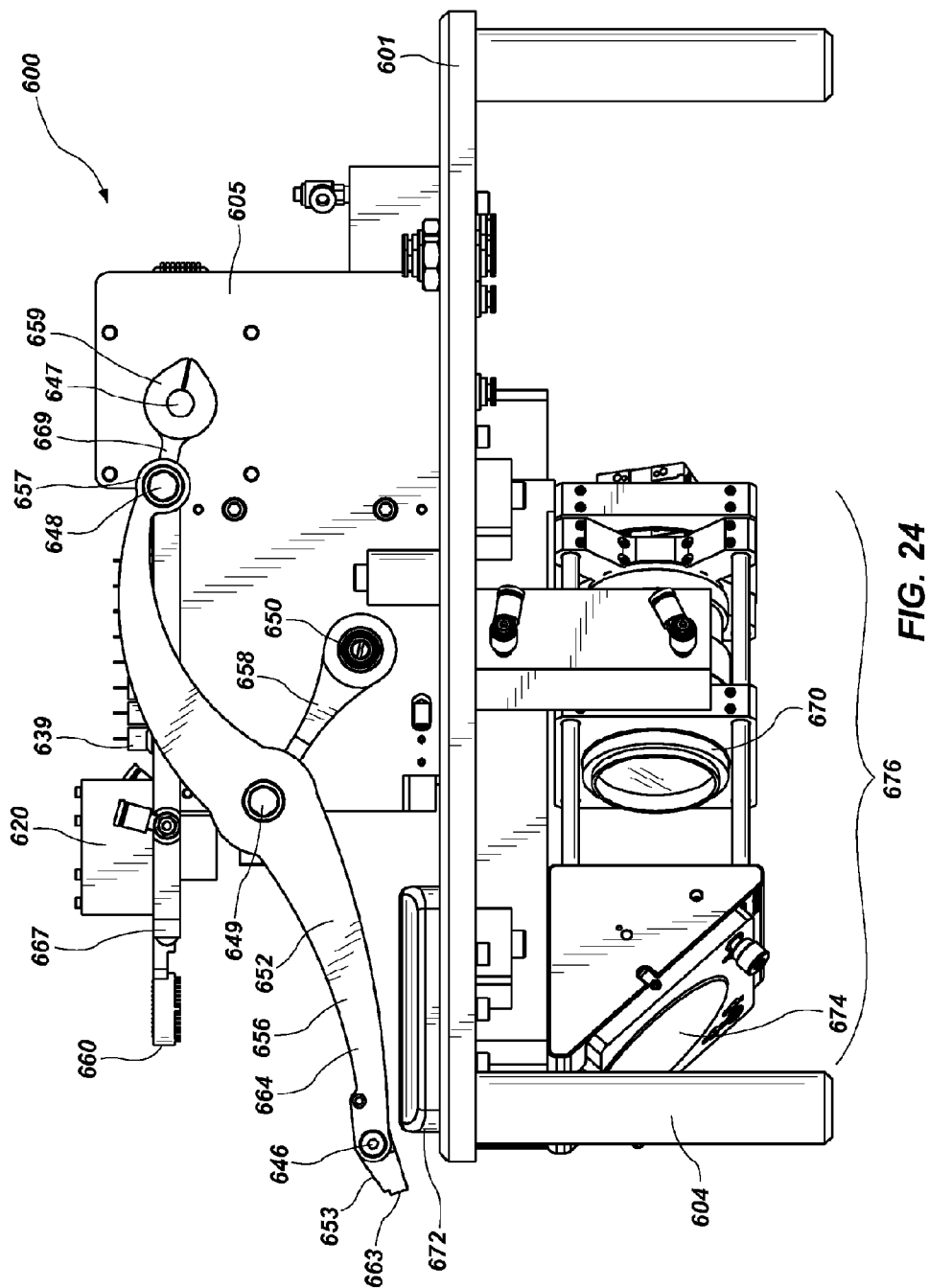

FIG. 24

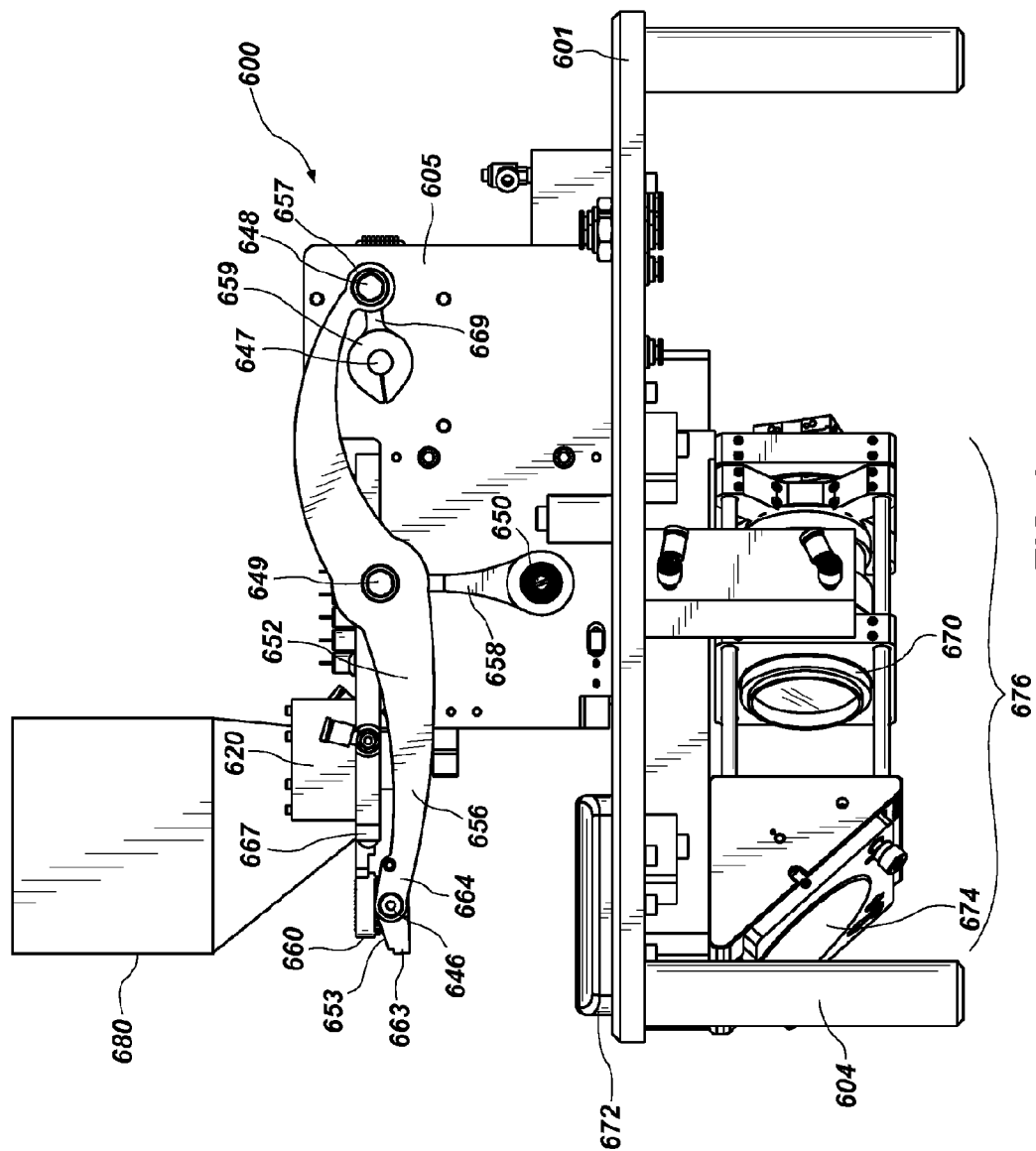

FIG. 25

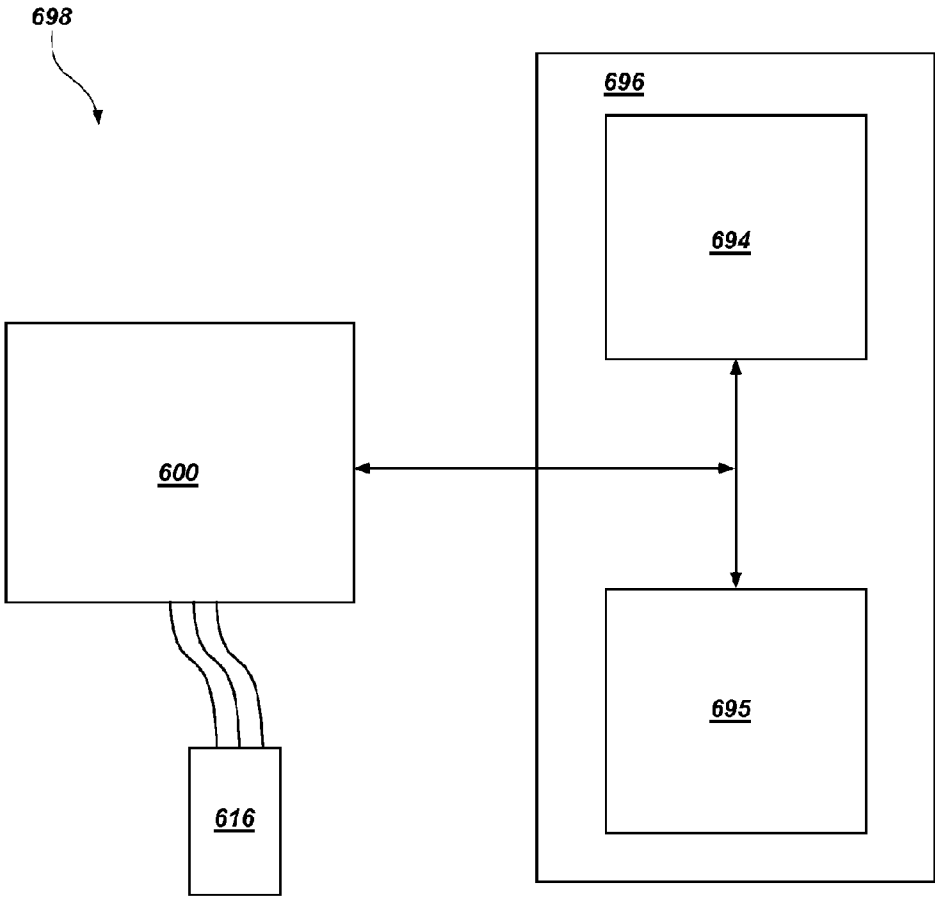

FIG. 26

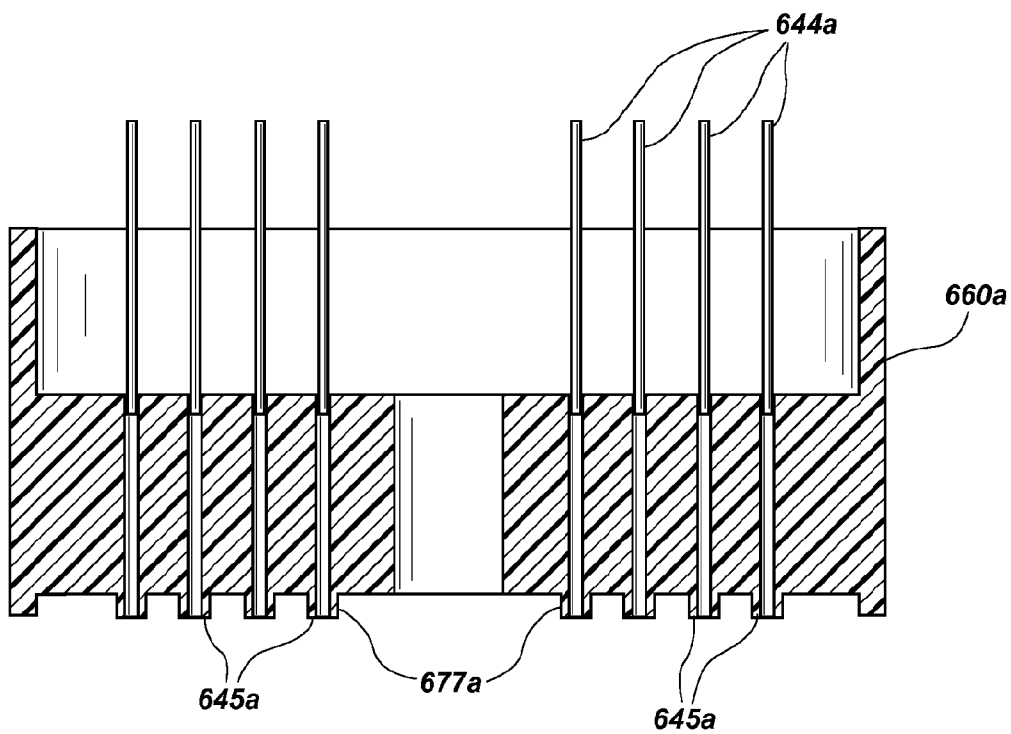

FIG. 27

MICROSPOTTING DEVICE

GOVERNMENT INTEREST

[0001] This invention was made with government support under Grant No. AI061611, awarded by National Institutes of Health. The U.S. Government has certain rights in the invention.

BACKGROUND OF THE INVENTION

[0002] In the United States, Canada, and Western Europe infectious disease accounts for approximately 7% of human mortality, while in developing regions infectious disease accounts for over 40% of human mortality. Infectious diseases lead to a variety of clinical manifestations. Among common overt manifestations are fever, pneumonia, meningitis, diarrhea, and diarrhea containing blood. While the physical manifestations suggest some pathogens and eliminate others as the etiological agent, a variety of potential causative agents remain, and clear diagnosis often requires a variety of assays be performed. Traditional microbiology techniques for diagnosing pathogens can take days or weeks, often delaying a proper course of treatment.

[0003] In recent years, the polymerase chain reaction (PCR) has become a method of choice for rapid diagnosis of infectious agents. PCR can be a rapid, sensitive, and specific tool to diagnose infectious disease. A challenge to using PCR as a primary means of diagnosis is the variety of possible causative organisms and the low levels of organism present in some pathological specimens. It is often impractical to run large panels of PCR assays, one for each possible causative organism, most of which are expected to be negative. The problem is exacerbated when pathogen nucleic acid is at low concentration and requires a large volume of sample to gather adequate reaction templates. In some cases there is inadequate sample to assay for all possible etiological agents. A solution is to run "multiplex PCR" wherein the sample is concurrently assayed for multiple targets in a single reaction. While multiplex PCR has proved to be valuable in some systems, shortcomings exist concerning robustness of high level multiplex reactions and difficulties for clear analysis of multiple products. To solve these problems, the assay may be subsequently divided into multiple secondary PCRs. Nesting secondary reactions within the primary product increases robustness. However, this further handling can be expensive and may lead to contamination or other problems.

[0004] The present invention addresses various issues of handling materials to perform biological analysis.

SUMMARY OF THE INVENTION

[0005] In one aspect of the invention, a spotter device for spotting a plurality of fluids into an array is described, the spotter device comprising a plurality of reservoirs provided in a first configuration, each reservoir holding its respective fluid, a print head having a plurality of positions provided in a second configuration, the second configuration being different from the first configuration, a plurality of tubes, each tube configured to provide fluid communication from a reservoir at a first end of the tube to a position in the print head at the second end of the tube, and a pump for pumping fluid through the tubes from the reservoir to the print head. Various features of the configuration of the spotter device, the pump, the print head, and other components are described herein.

[0006] In another aspect of the invention a method for printing an array having a plurality of wells in a configuration is provided. The method comprises simultaneously pumping fluid from a plurality of reservoirs to a plurality of positions on a print head to form a plurality of drops on the print head having the same configuration as the array, moving the array into contact with the drops, and simultaneously transferring each respective drop into its respective well. Arrays manufactured by such methods are also disclosed.

[0007] In yet another aspect, a system is provided for delivering one or more liquids into a preselected array of a plurality of wells, the system comprising a plurality of tubes, each tube having a first end in fluid communication with a reservoir, and a second end terminating in an orifice; a plurality of reservoirs, the reservoirs provided in a predetermined configuration relative to one another; a print head operable to movably hold each orifice in a predetermined position such that the position of each orifice corresponds to a well in the preselected array of wells; a plurality of straws, each straw having a hollow opening connecting a first end to a second end, the first end fluidly connected to the first end of a corresponding tube and the second end removably in contact with a bottom portion of a corresponding reservoir; and a metering device operable to urge a preselected amount of fluid from the second end of each straw through its corresponding tube, and out its corresponding orifice.

[0008] Additional features of the present invention will become apparent to those skilled in the art upon consideration of the following detailed description of preferred embodiments exemplifying the best mode of carrying out the invention as presently perceived.

BRIEF DESCRIPTION OF THE DRAWINGS

[0009] FIG. 1 shows a flexible pouch according to one embodiment of this invention.

[0010] FIG. 2 shows an embodiment of the cell lysis zone of the flexible pouch according to FIG. 1.

[0011] FIG. 2a shows an embodiment of a portion of a bladder corresponding to the cell lysis zone shown in FIG. 2.

[0012] FIG. 2b shows an embodiment of the cell lysis zone of the flexible pouch according to FIG. 1 having an alternative vortexing mechanism.

[0013] FIG. 3 shows an embodiment of the nucleic acid preparation zone of the flexible pouch according to FIG. 1.

[0014] FIG. 4 shows an embodiment of the first-stage amplification zone of the flexible pouch according to FIG. 1.

[0015] FIG. 5 is similar to FIG. 1, except showing an alternative embodiment of a pouch.

[0016] FIG. 5a is a cross-sectional view of the fitment of the pouch of FIG. 5.

[0017] FIG. 5b is an enlargement of a portion of the pouch of FIG. 5.

[0018] FIG. 6 is a perspective view of another alternative embodiment of a pouch.

[0019] FIG. 6a is a cross-sectional view of the fitment of the pouch of FIG. 6.

[0020] FIG. 7 shows illustrative bladder components for use with the pouch of FIG. 6.

[0021] FIG. 8 is an exploded perspective view of an instrument for use with the pouch of FIG. 6, including the pouch of FIG. 6.

[0022] FIG. 9 shows a partial cross-sectional view of the instrument of FIG. 8, including the bladder components of FIG. 7, with the pouch of FIG. 6 shown in shadow.

[0023] FIG. 10 shows a partial cross-sectional view of the instrument of FIG. 8, including various bladders for pinch valves and the pouch of FIG. 6.

[0024] FIG. 11 shows amplification curves from second-stage amplification of a sample that was lysed and amplified in a pouch of FIG. 5 (—positive control;—*S. cerevisiae* target 1;—*S. cerevisiae* target 2;—*S. cerevisiae* target 3;—*S. pombe* target 1;—*S. pombe* target 2;—negative controls).

[0025] FIG. 12 is similar to FIG. 6, except showing a pouch having a second-stage high density array.

[0026] FIG. 13 shows a modification of a component of the instrument of FIG. 8. A support member has been provided with a motor configured for use with the pouch of FIG. 12.

[0027] FIG. 14 is an exploded perspective view of the second-stage high density array of FIG. 12.

[0028] FIG. 15 is a bottom view of the second-stage high density array of FIG. 12, shown during construction of the second-stage high density array.

[0029] FIG. 16 shows a partially constructed high-density array similar to that shown in FIGS. 14-15, except with a different arrangement of wells.

[0030] FIG. 17 shows a perspective view of a spotter with the placement arm removed to allow detail underneath to be seen.

[0031] FIG. 18 is similar to FIG. 17, except that the placement arm is shown.

[0032] FIG. 19 is a right side view of a portion of the spotter of FIG. 18.

[0033] FIG. 20 is a cross-sectional view along line 20-20 in FIG. 17.

[0034] FIG. 21 is a cross-sectional view along line 21-21 in FIG. 17.

[0035] FIG. 22 is a bottom view of the print head of FIG. 17, showing 96 sufficient drops.

[0036] FIG. 23 is similar to FIG. 22 is similar to FIG. 22, except that only 76 drops are shown.

[0037] FIG. 24 is a right side view of the spotter of FIG. 18, showing detail of the placement arm.

[0038] FIG. 25 is similar to FIG. 24, except that the placement arm has moved the array into contact with the print head.

[0039] FIG. 26 is a schematic of a spotter system.

DETAILED DESCRIPTION

[0040] The self-contained nucleic acid analysis pouches described herein may be used to assay a sample for the presence of various biological substances, illustratively antigens and nucleic acid sequences, illustratively in a single closed system. In one embodiment, the pouch is used to assay for multiple pathogens. Illustratively, various steps may be performed in the optionally disposable pouch, including nucleic acid preparation, primary large volume multiplex PCR, dilution of primary amplification product, and secondary PCR, culminating with real-time detection and/or post-amplification analysis such as melting-curve analysis. It is understood, however, that pathogen detection is one exemplary use and the pouches may be used for other nucleic acid analysis or detection of other substances, including but not limited to peptides, toxins, and small molecules. Further, it is understood that while the various steps may be performed in pouches of the present invention, one or more of the steps may be omitted for certain uses, and the pouch configuration may be altered accordingly.

[0041] While PCR is the amplification method used in the examples herein, it is understood that any amplification

method that uses a primer may be suitable. Such suitable procedures include polymerase chain reaction (PCR); strand displacement amplification (SDA); nucleic acid sequence-based amplification (NASBA); cascade rolling circle amplification (CRCA), loop-mediated isothermal amplification of DNA (LAMP); isothermal and chimeric primer-initiated amplification of nucleic acids (ICAN); target based-helicase dependant amplification (HDA); transcription-mediated amplification (TMA), and the like. Therefore, when the term PCR is used, it should be understood to include other alternative amplification methods. It is understood that protocols may need to be adjusted accordingly.

[0042] FIG. 1 shows an illustrative self-contained nucleic acid analysis pouch 10. Pouch 10 has a cell lysis zone 20, a nucleic acid preparation zone 40, a first-stage amplification zone 60, and a second-stage amplification zone 80. A sample containing nucleic acid is introduced into the pouch 10 via sample injection port 12. Pouch 10 comprises a variety of channels and blisters of various sizes and is arranged such that the sample flows through the system. The sample passes through the various zones and is processed accordingly.

[0043] Sample processing occurs in various blisters located within pouch 10. Various channels are provided to move the sample within and between processing zones, while other channels are provided to deliver fluids and reagents to the sample or to remove such fluids and reagents from the sample. Liquid within pouch 10 illustratively is moved between blisters by pressure, illustratively pneumatic pressure, as described below, although other methods of moving material within the pouch are contemplated.

[0044] While other containers may be used, illustratively, pouch 10 is formed of two layers of a flexible plastic film or other flexible material such as polyester, polyethylene terephthalate (PET), polycarbonate, polypropylene, polymethylmethacrylate, and mixtures thereof that can be made by any process known in the art, including extrusion, plasma deposition, and lamination. Metal foils or plastics with aluminum lamination also may be used. Other barrier materials are known in the art that can be sealed together to form the blisters and channels. If plastic film is used, the layers may be bonded together, illustratively by heat sealing. Illustratively, the material has low nucleic acid binding capacity.

[0045] For embodiments employing fluorescent monitoring, plastic films that are adequately low in absorbance and auto-fluorescence at the operative wavelengths are preferred. Such material could be identified by trying different plastics, different plasticizers, and composite ratios, as well as different thicknesses of the film. For plastics with aluminum or other foil lamination, the portion of the pouch that is to be read by a fluorescence detection device can be left without the foil. For example, if fluorescence is monitored in the blisters 82 of the second stage amplification zone 80 of pouch 10, then one or both layers at blisters 82 would be left without the foil. In the example of PCR, film laminates composed of polyester (Mylar, Dupont, Wilmington Del.) of about 0.0048 inch (0.1219 mm) thick and polypropylene films of 0.001-0.003 inch (0.025-0.076 mm) thick perform well. Illustratively, pouch 10 is made of a clear material capable of transmitting approximately 80%-90% of incident light.

[0046] In the illustrative embodiment, the materials are moved between blisters by the application of pressure, illustratively pneumatic pressure, upon the blisters and channels. Accordingly, in embodiments employing pneumatic pressure, the pouch material illustratively is flexible enough to

allow the pneumatic pressure to have the desired effect. The term “flexible” is herein used to describe a physical characteristic of the material of pouch. The term “flexible” is herein defined as readily deformable by the levels of pneumatic pressure used herein without cracking, breaking, crazing, or the like. For example, thin plastic sheets, such as Saran™ wrap and Ziploc® bags, as well as thin metal foil, such as aluminum foil, are flexible. However, only certain regions of the blisters and channels need be flexible, even in embodiments employing pneumatic pressure. Further, only one side of the blisters and channels need to be flexible, as long as the blisters and channels are readily deformable. Other regions of the pouch **10** may be made of a rigid material or may be reinforced with a rigid material.

[0047] Illustratively, a plastic film is used for pouch **10**. A sheet of metal, illustratively aluminum, or other suitable material, may be milled or otherwise cut, to create a die having a pattern of raised surfaces. When fitted into a pneumatic press (illustratively A-5302-PDS, Janesville Tool Inc., Milton Wis.), illustratively regulated at an operating temperature of 195° C., the pneumatic press works like a printing press, melting the sealing surfaces of plastic film only where the die contacts the film. Various components, such as PCR primers (illustratively spotted onto the film and dried), antigen binding substrates, magnetic beads, and zirconium silicate beads may be sealed inside various blisters as the pouch **10** is formed. Reagents for sample processing can be spotted onto the film prior to sealing, either collectively or separately. In one embodiment, nucleotide tri-phosphates (NTPs) are spotted onto the film separately from polymerase and primers, essentially eliminating activity of the polymerase until the reaction is hydrated by an aqueous sample. If the aqueous sample has been heated prior to hydration, this creates the conditions for a true hot-start PCR and reduces or eliminates the need for expensive chemical hot-start components. This separate spotting is discussed further below, with respect to FIG. **5b**, but it is understood that such spotting may be used with any of the embodiments discussed herein.

[0048] When pneumatic pressure is used to move materials within pouch **10**, in one embodiment a “bladder” may be employed. The bladder assembly **710**, a portion of which is shown in FIG. **2a**, may be manufactured in a process similar to that of making the pouch, but individual blisters in the bladder assembly **710** include pneumatic fittings (illustratively fitting **724a**) allowing individual bladders within the bladder assembly **710** to be pressurized by a compressed gas source. Because the bladder assembly is subjected to compressed gas and may be used multiple times, the bladder assembly may be made from tougher or thicker material than the pouch. Alternatively, bladders may be formed from a series of plates fastened together with gaskets, seals, valves, and pistons. Other arrangements are within the scope of this invention.

[0049] When pouch **10** is placed within the instrument, the pneumatic bladder assembly **710** is pressed against one face of the pouch **10**, so that if a particular bladder is inflated, the pressure will force the liquid out of the corresponding blister in the pouch **10**. In addition to pneumatic bladders corresponding to many of the blisters of pouch **10**, the bladder assembly may have additional pneumatic actuators, such as bladders or pneumatically-driven pistons, corresponding to various channels of pouch **10**. When activated, these additional pneumatic actuators form pinch valves to pinch off and close the corresponding channels. To confine liquid within a

particular blister of pouch **10**, the pinch valve pneumatic actuators are inflated over the channels leading to and from the blister, such that the actuators function as pinch valves to pinch the channels shut. Illustratively, to mix two volumes of liquid in different blisters, the pinch valve pneumatic actuator sealing the connecting channel is depressurized, and the pneumatic bladders over the blisters are alternately pressurized, forcing the liquid back and forth through the channel connecting the blisters to mix the liquid therein. The pinch valve pneumatic actuators may be of various shapes and sizes and may be configured to pinch off more than one channel at a time. Such an illustrative pinch valve is illustrated in FIG. **1** as pinch valve **16**, which may be used to close all injection ports. While pneumatic actuators are discussed herein, it is understood that other ways of providing pressure to the pouch are contemplated, including various electromechanical actuators such as linear stepper motors, motor-driven cams, rigid paddles driven by pneumatic, hydraulic or electromagnetic forces, rollers, rocker-arms, and in some cases, cocked springs. In addition, there are a variety of methods of reversibly or irreversibly closing channels in addition to applying pressure normal to the axis of the channel. These include kinking the bag across the channel, heat-sealing, rolling an actuator, and a variety of physical valves sealed into the channel such as butterfly valves and ball valves. Additionally, small Peltier devices or other temperature regulators may be placed adjacent the channels and set at a temperature sufficient to freeze the fluid, effectively forming a seal. Also, while the design of FIG. **1** is adapted for an automated instrument featuring actuator elements positioned over each of the blisters and channels, it is also contemplated that the actuators could remain stationary, and the pouch could be transitioned in one or two dimensions such that a small number of actuators could be used for several of the processing stations including sample disruption, nucleic-acid capture, first and second-stage PCR, and other applications of the pouch such as immuno-assay and immuno-PCR. Rollers acting on channels and blisters could prove particularly useful in a configuration in which the pouch is translated between stations. Thus, while pneumatic actuators are used in the presently disclosed embodiments, when the term “pneumatic actuator” is used herein, it is understood that other actuators and other ways of providing pressure may be used, depending on the configuration of the pouch and the instrument.

[0050] With reference to FIG. **1**, an illustrative sample pouch **10** configured for nucleic acid extraction and multiplex PCR is provided. The sample enters pouch **10** via sample injection port **12** in fitment **90**. Injection port **12** may be a frangible seal, a one-way valve, or other entry port. Vacuum from inside pouch **10** may be used to draw the sample into pouch **10**, a syringe or other pressure may be used to force the sample into pouch **10**, or other means of introducing the sample into pouch **10** via injector port **12** may be used. The sample travels via channel **14** to the three-lobed blister **22** of the cell lysis zone **20**, wherein cells in the sample are lysed. Once the sample enters three-lobed blister **22**, pinch valve **16** is closed. Along with pinch valve **36**, which may have been already closed, the closure of pinch valve **16** seals the sample in three-lobed blister **22**. It is understood that cell lysis may not be necessary with every sample. For such samples, the cell lysis zone may be omitted or the sample may be moved directly to the next zone. However, with many samples, cell lysis is needed. In one embodiment, bead-milling is used to lyse the cells.

[0051] Bead-milling, by shaking or vortexing the sample in the presence of lysing particles such as zirconium silicate (ZS) beads 34, is an effective method to form a lysate. It is understood that, as used herein, terms such as “lyse,” “lysing,” and “lysate” are not limited to rupturing cells, but that such terms include disruption of non-cellular particles, such as viruses. FIG. 2 displays one embodiment of a cell lysis zone 20, where convergent flow creates high velocity bead impacts, to create lysate. Illustratively, the two lower lobes 24, 26 of three-lobed blister 22 are connected via channel 30, and the upper lobe 28 is connected to the lower lobes 24, 26 at the opposing side 31 of channel 30. FIG. 2a shows a counterpart portion of the bladder assembly 710 that would be in contact with the cell lysis zone 20 of the pouch 10. When pouch 10 is placed in an instrument, adjacent each lobe 24, 26, 28 on pouch 10 is a corresponding pneumatic bladder 724, 726, 728 in the bladder assembly 710. It is understood that the term “adjacent,” when referring to the relationship between a blister or channel in a pouch and its corresponding pneumatic actuator, refers to the relationship between the blister or channel and the corresponding pneumatic actuator when the pouch is placed into the instrument. In one embodiment, the pneumatic fittings 724a, 726a of the two lower pneumatic bladders 724, 726 adjacent lower lobes 24, 26 are plumbed together. The pneumatic fittings 724a, 726a and the pneumatic fitting 728a of upper pneumatic bladder 728 adjacent upper lobe 28 are plumbed to the opposing side of an electrically actuated valve configured to drive a double-acting pneumatic cylinder. Thus configured, pressure is alternated between the upper pneumatic bladder 728 and the two lower pneumatic bladders 724, 726. When the valve is switched back and forth, liquid in pouch 10 is driven between the lower lobes 24, 26 and the upper lobe 28 through a narrow nexus 32 in channel 30. As the two lower lobes 24, 26 are pressurized at the same time, the flow converges and shoots into the upper lobe 28. Depending on the geometry of the lobes, the collision velocity of beads 34 at the nexus 32 may be at least about 12 m/sec, providing high-impact collisions resulting in lysis. The illustrative three-lobed system allows for good cell disruption and structural robustness, while minimizing size and pneumatic gas consumption. While ZS beads are used as the lysing particles, it is understood that this choice is illustrative only, and that other materials and particles of other shapes may be used. It is also understood that other configurations for cell lysis zone 20 are within the scope of this invention.

[0052] While a three-lobed blister is used for cell lysis, it is understood that other multi-lobed configurations are within the scope of this invention. For instance, a four-lobed blister, illustratively in a cloverleaf pattern, could be used, wherein the opposite blisters are pressurized at the same time, forcing the lysing particles toward each other, and then angling off to the other two lobes, which then may be pressurized together. Such a four-lobed blister would have the advantage of having high-velocity impacts in both directions. Further, it is contemplated that single-lobed blisters may be used, wherein the lysing particles are moved rapidly from one portion of the single-lobed blister to the other. For example, pneumatic actuators may be used to close off areas of the single-lobed blister, temporarily forming a multi-lobed blister in the remaining areas. Other actuation methods may also be used such as motor, pneumatic, hydraulic, or electromagnetically-driven paddles acting on the lobes of the device. Rollers or rotary paddles can be used to drive fluid together at the nexus 32 of FIG. 2, illustratively if a recirculation means is provided

between the upper and lower lobes and the actuator provides peristaltic pumping action. Other configurations are within the scope of this invention.

[0053] It may also be possible to move the sample and lysing particles quickly enough to effect lysis within a single-lobed lysis blister without temporarily forming a multi-lobed blister. In one such alternative embodiment, as shown in FIG. 2b, vortexing may be achieved by impacting the pouch with rotating blades or paddles 21 attached to an electric motor 19. The blades 21 may impact the pouch at the lysis blister or may impact the pouch near the lysis blister, illustratively at an edge 17 adjacent the lysis blister. In such an embodiment, the lysis blister may comprise one or more blisters. FIG. 12 shows an embodiment comprising one such lysis blister 522. FIG. 13 shows a bead beating motor 19, comprising blades 21, that may be mounted on a first side 811 of second support member 804, of instrument 800 shown in FIG. 8. It is understood, however, that motor 19 may be mounted on first support member 802 or on other structure of instrument 800.

[0054] FIG. 2a also shows pneumatic bladder 716 with pneumatic fitting 716a, and pneumatic bladder 736 with pneumatic fitting 736a. When the pouch 10 is placed in contact with bladder assembly 710, bladder 716 lines up with channel 12 to complete pinch valve 16. Similarly, bladder 736 lines up with channel 38 to complete pinch valve 36. Operation of pneumatic bladders 716 and 736 allow pinch valves 16 and 36 to be opened and closed.

[0055] While only the portion of bladder assembly 710 adjacent the cell lysis zone is shown, it is understood that bladder assembly 710 would be provided with similar arrangements of pneumatic blisters to control the movement of fluids throughout the remaining zones of pouch 10.

[0056] Other prior art instruments teach PCR within a sealed flexible container. See, e.g., U.S. Pat. Nos. 6,645,758 and 6,780,617, and co-pending U.S. patent application Ser. No. 10/478,453, herein incorporated by reference. However, including the cell lysis within the sealed PCR vessel can improve ease of use and safety, particularly if the sample to be tested may contain a biohazard. In the embodiments illustrated herein, the waste from cell lysis, as well as that from all other steps, remains within the sealed pouch. However, it is understood that the pouch contents could be removed for further testing.

[0057] Once the cells are lysed, pinch valve 36 is opened and the lysate is moved through channel 38 to the nucleic acid preparation zone 40, as best seen in FIG. 3, after which, pinch valve 36 is closed, sealing the sample in nucleic acid preparation zone 40. In the embodiment illustrated in FIG. 3, purification of nucleic acids takes the bead-milled material and uses affinity binding to silica-based magnetic-beads 56, washing the beads with ethanol, and eluting the nucleic acids with water or other fluid, to purify the nucleic acid from the cell lysate. The individual components needed for nucleic acid extraction illustratively reside in blisters 44, 46, 48, which are connected by channels 45, 47, 49 to allow reagent mixing. The lysate enters blister 44 from channel 38. Blister 44 may be provided with magnetic beads 56 and a suitable binding buffer, illustratively a high-salt buffer such as that of 1-2-3™ Sample Preparation Kit (Idaho Technology, Salt Lake City, Utah) or either or both of these components may be provided subsequently through one or more channels connected to blister 44. The nucleic acids are captured on beads 56, pinch valve 53 is then opened, and the lysate and beads 56 may be mixed by gentle pressure alternately on blisters 44 and

58 and then moved to blister **58** via pneumatic pressure illustratively provided by a corresponding pneumatic bladder on bladder assembly **710**. The magnetic beads **56** are captured in blister **58** by a retractable magnet **50**, which is located in the instrument adjacent blister **58**, and waste may be moved to a waste reservoir or may be returned to blister **44** by applying pressure to blister **58**. Pinch valve **53** is then closed. The magnetic beads **56** are washed with ethanol, isopropanol, or other organic or inorganic wash solution provided from blister **46**, upon release of pinch valve **55**. Optionally, magnet **50** may be retracted allowing the beads to be washed by providing alternate pressure on blisters **46** and **58**. The beads **56** are once again captured in blister **58** by magnet **50**, and the non-nucleic acid portion of the lysate is washed from the beads **56** and may be moved back to blister **46** and secured by pinch valve **55** or may be washed away via another channel to a waste reservoir. Once the magnetic beads are washed, pinch valve **57** is opened, releasing water (illustratively buffered water) or another nucleic acid eluant from blister **48**. Once again, the magnet **50** may be retracted to allow maximum mixing of water and beads **56**, illustratively by providing alternate pressure on blisters **48** and **58**. The magnet **50** is once again deployed to collect beads **56**. Pinch valve **59** is released and the eluted nucleic acid is moved via channel **52** to first-stage amplification zone **60**. Pinch valve **59** is then closed, thus securing the sample in first-stage amplification zone **60**.

[0058] It is understood that the configuration for the nucleic acid preparation zone **40**, as shown in FIG. 3 and described above, is illustrative only, and that various other configurations are possible within the scope of the present disclosure.

[0059] The ethanol, water, and other fluids used herein may be provided to the blisters in various ways. The fluids may be stored in the blisters, the necks of which may be pinched off by various pinch valves or frangible portions that may be opened at the proper time in the sample preparation sequence. Alternatively, fluid may be stored in reservoirs in the pouch as shown pouch **110** in FIG. 5, or in the fitment as discussed with respect to pouch **210** of FIG. 6, and moved via channels, as necessary. In still another embodiment, the fluids may be introduced from an external source, as shown in FIG. 1, especially with respect to ethanol injection ports **41**, **88** and plungers **67**, **68**, **69**. Illustratively, plungers **67**, **68**, **69** may be inserted into fitment **90**, illustratively of a more rigid material, and may provide a measured volume of fluid upon activation of the plunger, as in U.S. Pat. No. 8,409,508, herein incorporated by reference. Alternatively, plunger may be a softer material and the fitment may be the more rigid material. The measured volume may be the same or different for each of the plungers. Finally, in yet another embodiment, the pouch may be provided with a measured volume of the fluid that is stored in one or more blisters, wherein the fluid is contained within the blister, illustratively provided in a small sealed pouch within the blister, effectively forming a blister within the blister. At the appropriate time, the sealed pouch may then be ruptured, illustratively by pneumatic pressure, thereby releasing the fluid into the blister of the pouch. The instrument may also be configured to provide some or all of the reagents directly through liquid contacts between the instrument and the fitment or pouch material provided that the passage of fluid is tightly regulated by a one-way valve to prevent the instrument from becoming contaminated during a run. Further, it will often be desirable for the pouch or its fitment to be sealed after operation to prohibit contaminating DNA to

escape from the pouch. Various means are known to provide reagents on demand such as syringe pumps, and to make temporary fluid contact with the fitment or pouch, such as barbed fittings or o-ring seals. It is understood that any of these methods of introducing fluids to the appropriate blister may be used with any of the embodiments of the pouch as discussed herein, as may be dictated by the needs of a particular application.

[0060] As discussed above, nested PCR involves target amplification performed in two stages. In the first-stage, targets are amplified, illustratively from genomic or reverse-transcribed template. The first-stage amplification may be terminated prior to plateau phase, if desired. In the secondary reaction, the first-stage amplicons may be diluted and a secondary amplification uses the same primers or illustratively uses nested primers hybridizing internally to the primers of the first-stage product. Advantages of nested PCR include: a) the initial reaction product forms a homogeneous and specific template assuring high fidelity in the secondary reaction, wherein even a relatively low-efficiency first-stage reaction creates adequate template to support robust second-stage reaction; b) nonspecific products from the first-stage reaction do not significantly interfere with the second stage reaction, as different nested primers are used and the original amplification template (illustratively genomic DNA or reverse-transcription product) may be diluted to a degree that eliminates its significance in the secondary amplification; and c) nested PCR enables higher-order reaction multiplexing. First-stage reactions can include primers for several unique amplification products. These products are then identified in the second-stage reactions. However, it is understood that first-stage multiplex and second-stage singleplex is illustrative only and that other configurations are possible. For example, the first-stage may amplify a variety of different related amplicons using a single pair of primers, and second-stage may be used to target differences between the amplicons, illustratively using melting curve analysis.

[0061] Turning back to FIG. 1, the nucleic acid sample enters the first-stage amplification zone **60** via channel **52** and is delivered to blister **61**. A PCR mixture, including a polymerase (illustratively a Taq polymerase), dNTPs, and primers, illustratively a plurality of pairs of primers for multiplex amplification, may be provided in blister **61** or may be introduced into blister **61** via various means, as discussed above. Alternatively, dried reagents may be spotted onto the location of blister **61** upon assembly of pouch **10**, and water or buffer may be introduced to blister **61**, illustratively via plunger **68**, as shown in FIG. 1. As best seen in FIG. 4, the sample is now secured in blister **61** by pinch valves **59** and **72**, and is thermocycled between two or more temperatures, illustratively by heat blocks or Peltier devices that are located in the instrument and configured to contact blister **61**. However, it is understood that other means of heating and cooling the sample contained within blister **61**, as are known in the art, are within the scope of this invention. Non-limiting examples of alternative heating/cooling devices for thermal cycling include having a air-cycled blister within the bladder, in which the air in the pneumatic blister adjacent blister **61** is cycled between two or more temperatures; or moving the sample to temperature zones within the blister **61**, illustratively using a plurality of pneumatic presses, as in U.S. patent application Ser. No. 10/478,453, herein incorporated by reference, or by translating pouch **10** on an axis or providing

pouch **10** with a rotary layout and spinning pouch **10** to move the contents between heat zones of fixed temperature.

[0062] Nucleic acids from pathogens are often co-isolated with considerable quantities of host nucleic acids. These host-derived nucleic acids often interact with primers, resulting in amplification of undesired products that then scavenge primers, dNTPs, and polymerase activity, potentially starving a desired product of resources. Nucleic acids from pathogenic organisms are generally of low abundance, and undesired product is a potential problem. The number of cycles in the first-stage reaction of zone **60** may be optimized to maximize specific products and minimize non-specific products. It is expected that the optimum number of cycles will be between about 10 to about 30 cycles, illustratively between about 15 to about 20 cycles, but it is understood that the number of cycles may vary depending on the particular target, host, and primer sequence.

[0063] Following the first-stage multiplex amplification, the first-stage amplification product is diluted, illustratively in incomplete PCR master mix, before fluidic transfer to secondary reaction sites.

[0064] FIG. 4 shows an illustrative embodiment for diluting the sample in three steps. In the first step, pinch valve **72** is opened and the sample undergoes a two-fold dilution by mixing the sample in blister **61** with an equal volume of water or buffer from blister **62**, which is provided to blister **62**, as well as blisters **64** and **66**, as discussed above. Squeezing the volume back and forth between blisters **61**, **62** provides thorough mixing. As above, mixing may be provided by pneumatic bladders provided in the bladder **710** and located adjacent blisters **61**, **62**. The pneumatic bladders may be alternately pressurized, forcing the liquid back and forth. During mixing, a pinch valve **74** prevents the flow of liquid into the adjacent blisters. At the conclusion of mixing, a volume of the diluted sample is captured in region **70**, and pinch valve **72** is closed, sealing the diluted sample in region **70**. Pinch valve **74** is opened and the sample is further diluted by water or buffer provided in either or both of blisters **63**, **64**. As above, squeezing the volume back and forth between blisters **63**, **64** provides mixing. Subsequently, pinch valve **74** is closed, sealing a further diluted volume of sample in region **71**. Final dilution takes place illustratively by using buffer or water provided in either or both of blisters **65**, **66**, with mixing as above. Illustratively this final dilution takes place using an incomplete PCR master mix (e.g., containing all PCR reagents except primers) as the fluid. Optional heating of the contents of blister **66** prior to second-stage amplification can provide the benefits of hot-start amplification without the need for expensive antibodies or enzymes. It is understood, however, that water or other buffer may be used for the final dilution, with additional PCR components provided in second-stage amplification zone **80**. While the illustrative embodiment uses three dilution stages, it is understood that any number of dilution stages may be used, to provide a suitable level of dilution. It is also understood that the amount of dilution can be controlled by adjusting the volume of the sample captured in regions **70** and **71**, wherein the smaller the amount of sample captured in regions **70** and **71**, the greater the amount of dilution or wherein additional aliquots captured in region **70** and/or region **71** by repeatedly opening and closing pinch valves **72** and **74** and/or pinch valves **74** and **76** may be used to decrease the amount of dilution. It is expected that about 10^{-2} to about 10^{-5} dilution would be suitable for many applications.

[0065] Success of the secondary PCR reactions is dependent upon template generated by the multiplex first-stage reaction. Typically, PCR is performed using DNA of high purity. Methods such as phenol extraction or commercial DNA extraction kits provide DNA of high purity. Samples processed through the pouch **10** may require accommodations be made to compensate for a less pure preparation. PCR may be inhibited by components of biological samples, which is a potential obstacle. Illustratively, hot-start PCR, higher concentration of taq polymerase enzyme, adjustments in $MgCl_2$ concentration, adjustments in primer concentration, and addition of adjuvants (such as DMSO, TMSO, or glycerol) optionally may be used to compensate for lower nucleic acid purity. While purity issues are likely to be more of a concern with first-stage amplification, it is understood that similar adjustments may be provided in the second-stage amplification as well.

[0066] While dilution and second-stage sample preparation are accomplished in the illustrative embodiment by retaining a small amount of amplified sample in the blisters and channels of the first-stage PCR portion of the pouch, it is understood that these processes may also be performed in other ways. In one such illustrative example, pre-amplified sample can be captured in a small cavity in a member, illustratively a translating or rotating member, able to move a fixed volume of sample from the first to the second-stage PCR reagent. A one microliter fraction of the pre-amplified sample, mixed with 100 microliters of fresh PCR reagent would yield a one-hundred-fold reduction in concentration. It is understood that this dilution is illustrative only, and that other volumes and dilution levels are possible. This approach could be accomplished by forcing the first-stage amplification product into the rigid fitment where it contacts one of the plungers **68** or **69** of FIG. 1. In such an embodiment, the plunger would be configured to carry a small fraction of the sample into contact with the adjacent dilution buffer or second-stage PCR buffer. Similarly a sliding element could be used to carry a small amount of the first-stage amplification product into contact with the second-stage reaction mix while maintaining a seal between the stages, and containing the amplified sample within the rigid fitment **90**.

[0067] Subsequent to first-stage PCR and dilution, channel **78** transfers the sample to a plurality of low volume blisters **82** for secondary nested PCR. In one illustrative embodiment, dried primers provided in the second-stage blisters are resuspended by the incoming aqueous material to complete the reaction mixture. Optionally, fluorescent dyes such as LCGreen® Plus (Idaho Technology, Salt Lake City, Utah) used for detection of double-stranded nucleic acid may be provided in each blister or may be added to the incomplete PCR master mix provided at the end of the serial dilution, although it is understood that LCGreen® Plus is illustrative only and that other dyes are available, as are known in the art. In another optional embodiment, dried fluorescently labeled oligonucleotide probes configured for each specific amplicon may be provided in each respective second-stage blister, along with the respective dried primers. Further, while pouch **10** is designed to contain all reactions and manipulations within, to reduce contamination, in some circumstances it may be desirable to remove the amplification products from each blister **82** to do further analysis. Other means for detection of the second-stage amplicon, as are known in the art, are within the scope of this invention. Once the sample is transferred to blisters **82**, pinch valves **84** and **86** are activated to

close off blisters **82**. Each blister **82** now contains all reagents needed for amplification of a particular target. Illustratively, each blister may contain a unique pair of primers, or a plurality of blisters **82** may contain the same primers to provide a number of replicate amplifications.

[0068] It is noted that the embodiments disclosed herein use blisters for the second-stage amplification, wherein the blisters are formed of the same or similar plastic film as the rest of the flexible portion. However, in many embodiments, the contents of the second-stage blisters are never removed from the second-stage blisters, and, therefore, there is no need for the second-stage reaction to take place in flexible blisters. It is understood that the second-stage reaction may take place in a plurality of rigid, semi-rigid, or flexible chambers that are fluidly connected to the blisters. The chambers could be sealed as in the present example by placing pressure on flexible channels that connect the chambers, or may be sealed in other ways, illustratively by heat sealing or use of one-way valves. Various embodiments discussed herein include blisters provided solely for the collection of waste. Since the waste may never be removed, waste could be collected in rigid, semi-rigid, or flexible chambers.

[0069] It is within the scope of this invention to do the second-stage amplification with the same primers used in the first-stage amplification (see U.S. Pat. No. 6,605,451). However, it is often advantageous to have primers in second-stage reactions that are internal to the first-stage product such that there is no or minimal overlap between the first- and second-stage primer binding sites. Dilution of first-stage product largely eliminates contribution of the original template DNA and first-stage reagents to the second-stage reaction. Furthermore, illustratively, second-stage primers with a T_m higher than those used in the first-stage may be used to potentiate nested amplification. Primer may be designed to avoid significant hairpins, hetero/homo-dimers and undesired hybridization. Because of the nested format, second-stage primers tolerate deleterious interactions far more so than primers used to amplify targets from genomic DNA in a single step. Optionally, hot-start is used on second-stage amplification.

[0070] If a fluorescent dye is included in second-stage amplification, illustratively as a dsDNA binding dye or as part of a fluorescent probe, as are known in the art, optics provided may be used to monitor amplification of one or more of the samples. Optionally, analysis of the shape of the amplification curve may be provided to call each sample positive or negative. Illustrative methods of calling the sample are discussed in U.S. Pat. No. 6,730,501, herein incorporated by reference. Alternatively, methods employing a crossing threshold may be used. A computer may be provided externally or within the instrument and may be configured to perform the methods and call the sample positive or negative based upon the presence or absence of second-stage amplification and may provide quantitative information about the starting template concentration by comparing characteristic parameters of the amplification curve (such as crossing threshold) to standard curves, or relative to other amplification curves within the run. It is understood, however, that other methods, as are known in the art, may be used to call each sample. Other analyses may be performed on the fluorescent information. One such non-limiting example is the use of melting curve analysis to show proper melting characteristics (e.g. T_m , melt profile shape) of the amplicon. The optics provided may be configured to capture images of all

blisters **82** at once, or individual optics may be provided for each individual blister. Other configurations are within the scope of this invention.

[0071] FIG. 5 shows an alternative pouch **110**. In this embodiment, various reagents are loaded into pouch **110** via fitment **190**. FIG. 5a shows a cross-section of fitment **190** with one of a plurality of plungers **168**. It is understood that, while FIG. 5a shows a cross-section through entry channel **115a**, as shown in the embodiment of FIG. 5, there are **12** entry channels present (entry channel **115a** through **115l**), each of which may have its own plunger **168** for use in fitment **190**, although in this particular configuration, entry channels **115c**, **115f**, and **115i** are not used. It is understood that a configuration having **12** entry channels is illustrative only, and that any number of entry channels and associated plungers may be used.

[0072] In the illustrative embodiment, an optional vacuum port **142** of fitment **190** is formed through a first surface **194** of fitment **190** to communicate with chamber **192**. Optional vacuum port **142** may be provided for communication with a vacuum or vacuum chamber (not shown) to draw out the air from within pouch **110** to create a vacuum within chamber **192** and the various blisters and chambers of pouch **110**. Plunger **168** is then inserted far enough into chamber **192** to seal off vacuum port **142**. Chamber **192** is illustratively provided under a predetermined amount of vacuum to draw a desired volume of liquid into chamber **192** upon use. Additional information on preparing chamber **192** may be found in U.S. Pat. No. 8,409,508, already incorporated by reference.

[0073] Illustrative fitment **190** further includes an injection port **141** formed in the second surface **195** of fitment **190**. Illustratively, injection port **141** is positioned closer to the plastic film portion of pouch **110** than vacuum port **142**, as shown in FIG. 5a, such that the plunger **168** is inserted far enough to seal off vacuum port **142**, while still allowing access to chamber **192** via injection port **141**. As shown, second surface **119** of plastic film portion **117** provides a penetrable seal **139** to prevent communication between chamber **192** and the surrounding atmosphere via injection port **141**. However, it is understood that second surface **119** optionally may not extend to injection port **141** and various other seals may be employed. Further, if another location for the seal is desired, for example on a first surface **194** of fitment **190**, injection port **141** may include a channel to that location on fitment **190**. U.S. patent application Ser. No. 10/512,255, already incorporated by reference, shows various configurations where the seal is located remotely from the injection port, and the seal is connected to the chamber via a channel. Also, U.S. Pat. No. 8,409,508 discloses various configurations where channels connect a single seal to multiple chambers. Variations in seal location, as well as connection of a single injection port to multiple chambers, are within the scope of this invention. Optionally, seal **139** may be fragile and may be broken upon insertion of a cannula (not shown), to allow a fluid sample from within the cannula to be drawn into or forced into chamber **192**.

[0074] The illustrative plunger **168** of the pouch assembly **110** is cylindrical in shape and has a diameter of approximately 5 mm to be press-fit into chamber **192**. Plunger **168** includes a first end portion **173** and an opposite second end portion **175**. As shown in FIG. 5a, a notch **169** of plunger **168** is formed in second end portion **175**. In use, second end portion **175** is inserted part way into chamber **192**, and notch **169** may be aligned with injection port **141** to allow a fluid

sample to be drawn into or injected into chamber 192, even when plunger 168 is inserted far enough that plunger 168 would otherwise be blocking injection port 141. Illustratively, a fluid is placed in a container (not shown) with a syringe having a cannulated tip that can be inserted into injection port 141 to puncture seal 139 therein. In using an air-evacuated pouch assembly 110, when seal 139 is punctured, the fluid is withdrawn from the container due to the negative pressure within chamber 192 relative to ambient air pressure. Fluid then passes through port 141 to fill chamber 192. At this point, the fluid usually does not flow into the plastic film portion 117 of pouch 110. Finally, the plunger 168 is inserted into chamber 192 such that second end portion 175 of plunger 168 approaches the bottom 191 of chamber 192, to push a measured amount of the reagent or sample into the plastic film portion 117. As shown, plunger 168 is configured such that upon full insertion, second end portion 175 does not quite meet bottom 191 of chamber 192. The remaining space is useful in trapping bubbles, thereby reducing the number of bubbles entering plastic film portion 117. However, in some embodiments it may be desirable for second end portion 175 to meet bottom 191 upon full insertion of plunger 168. In the embodiment shown in FIG. 5, entry channels 115a, 115b, 115d, 115e, 115g, 115h, 115j, 115k, and 115l all lead to reaction zones or reservoir blisters. It is understood that full insertion of the plunger associated with entry channel 115a would force a sample into three-lobed blister 122, full insertion of the plunger associated with entry channel 115b would force a reagent into reservoir blister 101, full insertion of the plunger associated with entry channel 115d would force a reagent into reservoir blister 102, full insertion of the plunger associated with entry channel 115e would force a reagent into reservoir blister 103, full insertion of the plunger associated with entry channel 115g would force a reagent into reservoir blister 104, full insertion of the plunger associated with entry channel 115h would force a reagent into reservoir blister 105, full insertion of the plunger associated with entry channel 115j would force a reagent into reservoir blister 106, full insertion of the plunger associated with entry channel 115k would force a reagent into reservoir blister 107, and full insertion of the plunger associated with entry channel 115l would force a reagent into reservoir blister 108.

[0075] If a plunger design is used including notch 169 as illustrated in the embodiment shown in FIG. 5a, the plunger 168 may be rotated prior to being lowered, so as to offset notch 169 and to close off injection port 141 from communication with chamber 192, to seal the contents therein. This acts to minimize any potential backflow of fluid through injection port 141 to the surrounding atmosphere, which is particularly useful when it is desired to delay in full insertion of the plunger. Although notch 169 is shown and described above with respect to plunger 168, it is within the scope of this disclosure to close off injection port 141 soon after dispensing the fluid sample into the chamber 192 by other means, such as depressing plunger 168 toward the bottom of chamber 192, heat sealing, unidirectional valves, or self-sealing ports, for example. If heat sealing is used as the sealing method, a seal bar could be included in the instrument such that all chambers are heat sealed upon insertion of the pouch into the instrument.

[0076] In the illustrative method, the user injects the sample into the injection port 141 associated with entry channel 115a, and water into the various other injection ports. The water rehydrates reagents that have been previously freeze-

dried into chambers 192 associated with each of entry channels 115b, 115d, 115e, 115g, 115h, 115j, 115k, and 115l. The water may be injected through one single seal and then be distributed via a channel to each of the chambers, as shown in FIG. 6 below, or the water could be injected into each chamber independently. Alternatively, rather than injecting water to rehydrate dried reagents, wet reagents such as lysis reagents, nucleic acid extraction reagents, and PCR reagents may be injected into the appropriate chambers 192 of the fitment 190.

[0077] Upon activation of the plunger 168 associated with entry channel 115a, the sample is forced directly into three-lobed blister 122 via channel 114. The user also presses the remaining plungers 168, forcing the contents out of each of the chambers 192 in fitment 190 and into reservoir blisters 101 through 108. At this point, pouch 110 is loaded into an instrument for processing. While instrument 800, shown in FIG. 8, is configured for the pouch 210 of FIG. 6, it is understood that modification of the configuration of the bladders of instrument 800 would render instrument 800 suitable for use with pouches 110 and 510, or with pouches of other configurations.

[0078] In one illustrative example, upon depression of the plungers 168, reservoir blister 101 now contains DNA-binding magnetic beads in isopropanol, reservoir blister 102 now contains a first wash solution, reservoir blister 103 now contains a second wash solution, reservoir blister 104 now contains a nucleic acid elution buffer, reservoir blister 105 now contains first-stage PCR reagents, including multiplexed first-stage primers, reservoir blister 106 now contains second-stage PCR reagents without primers, reservoir blister 107 now contains negative control PCR reagents without primers and without template, and reservoir blister 108 now contains positive control PCR reagents with template. However, it is understood that these reagents are illustrative only, and that other reagents may be used, depending upon the desired reactions and optimization conditions.

[0079] Once pouch 110 has been placed into instrument 800 and the sample has been moved to three-lobed blister 122, the sample may be subjected to disruption by agitating the sample with lysing particles such as ZS or ceramic beads. The lysing particles may be provided in three-lobed blister 122, or may be injected into three-lobed blister 122 along with the sample. The three-lobed blister 122 of FIG. 5 is operated in much the same way as three-lobed blister 22 of FIG. 1, with the two lower lobes 124, 126 pressurized together, and pressure is alternated between the upper lobe 128 and the two lower lobes 124, 126. However, as illustrated, lower lobes 124, 126 are much more rounded than lower lobes 24, 26, allowing for a smooth flow of beads to channel 130 and allowing for high-speed collisions, even without the triangular flow separator at nexus 32. As with three-lobed blister 22, three-lobed blister 122 of FIG. 5 allows for effective lysis or disruption of microorganisms, cells, and viral particles in the sample. It has been found that a channel 130 having a width of about 3-4 mm, and illustratively about 3.5 mm, remains relatively clear of beads during lysis and is effective in providing for high-velocity collisions.

[0080] After lysis, nucleic-acid-binding magnetic beads are injected into upper lobe 128 via channel 138 by pressurizing a bladder positioned over reservoir blister 101. The magnetic beads are mixed, illustratively more gently than with during lysis, with the contents of three-lobed blister 122,

and the solution is incubated, illustratively for about 1 minute, to allow nucleic acids to bind to the beads.

[0081] The solution is then pumped into the “figure 8” blister **144** via channel **143**, where the beads are captured by a retractable magnet housed in the instrument, which is illustratively pneumatically driven. The bead capture process begins by pressurizing all lobes **124**, **126**, and **128** of the bead milling apparatus **122**. This forces much of the liquid contents of **122** through channel **143** and into blister **144**. A magnet is brought into contact with the lower portion **144b** of blister **144** and the sample is incubated for several seconds to allow the magnet to capture the beads from the solution, then the bladders adjacent to blister **122** are depressurized, the bladders adjacent blister portions **144a** and **144b** are pressurized, and the liquid is forced back into blister **122**. Since not all of the beads are captured in a single pass, this process may be repeated up to **10** times to capture substantially all of the beads in blister **144**. Then the liquid is forced out of blister **144**, leaving behind only the magnetic beads and the captured nucleic acids, and wash reagents are introduced into blister **144** in two successive washes (from reservoir blisters **102** and **103** via channels **145** and **147**, respectively). In each wash, the bladder positioned over the reservoir blister containing the wash reagent is pressurized, forcing the contents into blister **144**. The magnet is withdrawn and the pellet containing the magnetic beads is disrupted by alternatively pressurizing each of two bladders covering each lobe **144a** and **144b** of blister **144**. When the upper lobe **144a** is compressed, the liquid contents are forced into the lower lobe **144b**, and when the lower lobe **144b** is compressed, the contents are forced into the upper lobe **144a**. By agitating the solution in blister **144** between upper lobe **144a** and lower lobe **144b**, the magnetic beads are effectively washed of impurities. A balance is maintained between inadequate agitation, leaving the pellet of beads undisturbed, and excessive agitation, potentially washing the nucleic acids from the surface of the beads and losing them with the wash reagents. After each wash cycle, the magnetic beads are captured via the magnet in blister **144** and the wash reagents are illustratively forced into three-lobed blister **122**, which now serves as a waste receptacle. However, it is understood that the used reservoir blisters may also serve as waste receptacles, or other blisters may be provided specifically as waste receptacles.

[0082] Nucleic acid elution buffer from reservoir blister **104** is then injected via channel **149** into blister **144**, the sample is once again agitated, and the magnetic beads are recaptured by employment of the magnet. The fluid mixture in blister **144** now contains nucleic acids from the original sample. Pressure on blister **144** moves the nucleic acid sample to the first stage PCR blister **161** via channel **152**, where the sample is mixed with first-stage PCR master mix containing multiple primer sets, the PCR master mix provided from reservoir blister **105** via channel **162**. If desired, the sample and/or the first-stage PCR master mix may be heated prior to mixing, to provide advantages of hot start. Optionally, components for reverse transcription of RNA targets may be provided prior to first-stage PCR. Alternatively, an RT enzyme, illustratively a thermostable RT enzyme may be provided in the first-stage PCR master mix to allow for contemporaneous reverse transcription of RNA targets. It is understood that an RT enzyme may be present in the first-stage PCR mixture in any of the embodiments disclosed herein. As will be seen below, pouch **110** of FIG. **5** is configured for up to **10** primer sets, but it is understood that the

configuration may be altered and any number of primer sets may be used. A bladder positioned over blister **161** is pressurized at low pressure, to force the contents of blister **161** into intimate contact with a heating/cooling element, illustratively a Peltier element, on the other side of blister **161**. The pressure on blister **161** should be sufficient to assure good contact with the heating/cooling element, but should be gentle enough such that fluid is not forced from blister **161**. The heating/cooling element is temperature cycled, illustratively between about **60° C.** to about **95° C.**

[0083] Illustratively, temperature cycling is performed for about **15-20** cycles, resulting in amplification of one or more nucleic acid targets present. Also illustratively, temperature cycling ceases prior to plateau phase, and may cease in log phase or even prior to log phase. In one example, it may be desirable merely to enrich the sample with the desired amplicons, without reaching minimal levels of detection. See U.S. Pat. No. 6,605,451, herein incorporated by reference.

[0084] The amplified sample is optionally then diluted by forcing most the sample back into blister **144** via channel **152**, leaving only a small amount (illustratively about **1** to **5%**) of the amplified sample in blister **161**, and second-stage PCR master mix is provided from reservoir blister **106** via channel **163**. The sample is thoroughly mixed illustratively by moving it back and forth between blisters **106** and **161** via channel **163**. If desired, the reaction mixture may be heated to above extension temperature, illustratively at least **60° C.**, prior to second-stage amplification. The sample is then forced through channel **165** into an array of low volume blisters **182** in the center of second-stage amplification zone **180**. Each of the ten illustrative low volume blisters **182** may contain a different primer pair, either essentially the same as one of the primer pairs in the first-stage amplification, or “nested” within the first-stage primer pair to amplify a shortened amplicon. The primers, now hydrated by the sample, complete the amplification mixture. Positive and negative control samples are also introduced by pressurizing the contents of reservoir blisters **107** and **108**, respectively, forcing PCR master mix either without target DNA from reservoir blister **107** via channel **166**, or with control DNA from reservoir blister **108**, via channel **167**. As illustrated, there are five each of positive control blisters **183** and negative control blisters **181**, which may be multiplexed **2-fold** to provide the necessary controls for ten different second-stage amplification reactions. It is understood that this configuration is illustrative only and that any number of second-stage blisters may be provided.

[0085] Illustratively, the PCR master mix used for second-stage amplification lacks the primers, but is otherwise complete. However, an “incomplete” PCR master mix may lack other PCR components as well. In one example, the second-stage PCR master mix is water or buffer only, which is then mixed with the optionally diluted first-stage PCR amplification product. This mixture is moved to the small-volume PCR reaction blisters, where all of the remaining components have been previously provided. If desired, all of the remaining components may be mixed together and spotted as a single mixture into the small-volume PCR reaction blisters. Alternatively, as illustrated in FIG. **5b**, each of the components may be spotted onto a separate region of the small-volume PCR reaction blister **182**. As shown in FIG. **5b**, four regions are present, illustratively with dNTPs spotted at region **182a**, primers spotted at **182b**, polymerase spotted at **182c**, and a magnesium compound spotted at **182d**. By spotting the com-

ponents separately and heating the sample mixture prior to rehydrating the components, nonspecific reactions can be minimized. It is understood that any combination of components can be spotted this way, and that this method of spotting components into one or more regions of the blisters may be used with any embodiment of the present invention.

[0086] The channels 165, 166, and 167 leading to the small-volume PCR reaction blisters 181, 182, and 183 are sealed, and a pneumatic bladder gently presses the array against a heating/cooling element, illustratively a Peltier element, for thermal cycling. The cycling parameters may be independently set for second-stage thermal cycling. Illustratively, the reactions are monitored by focusing an excitation source, illustratively a blue light (450-490 nm), onto the array, and imaging the resultant fluorescent emissions, illustratively fluorescent emissions above 510 nm.

[0087] In the above example, pinch valves are not discussed. However, it is understood that when it is desired to contain a sample in one of the blisters, pneumatic actuators positioned over channels leading to and from the particular blister are pressurized, creating pinch valves and closing off the channels. Conversely, when it is desired to move a sample from one of the blisters, the appropriate pneumatic actuator is depressurized, allowing the sample flow through the channel.

[0088] The pouch described above in FIG. 5 includes reagent reservoir blisters 101 through 108, in which the user injected reagents from the fitment 190 into the reagent reservoir blisters 101 through 108 in the plastic film portion 117 of the pouch 110, illustratively prior to insertion of pouch 110 into the instrument. While there are advantages to the use of the reagent reservoir blisters of FIG. 5, including having the ability to maintain the contents of the various blisters at different temperatures, there are some disadvantages as well. Because the operator is responsible for moving the reagents from the fitment 190 to the reservoir blisters 101 through 108, and because this is often done outside of the machine and thus without activated pinch valves, reagents could occasionally leak from the reservoir blisters to the working blisters. The reagents in reservoir blisters are exposed during preparation and loading. If they are pressed, squeezed, or even lightly bumped, the reagents may leak through available channels. If the loss of reagents is substantial, the reaction may fail completely. Furthermore, during operation there may be some variability in the amount of reagent forced from the reservoir blisters 101 through 108, leading to inconsistent results. Automation of introduction of the reagents to fitment 190 and movement of the reagents from fitment 190 to reagent reservoir blisters 101 through 108 would solve many of these problems, and is within the scope of this invention.

[0089] The pouch 210 of FIG. 6 addresses many of these issues in a different way, by using a direct-injection approach wherein the instrument itself moves the plungers 268, illustratively via pneumatic pistons, and forces the reagents into the various working blisters as the reagents are needed. Rather than storing the reagents in reservoir blisters 101 through 108 of FIG. 5, in the embodiment of FIG. 6 the reagents are introduced into various chambers 292 of fitment 290 and are maintained there until needed. Pneumatic operation of piston 268 at the appropriate time introduces a measured amount of the reagent to the appropriate reaction blister. In addition to addressing many of the above-mentioned issues, pouch 210 also has a much more compact shape,

allowing for a smaller instrument design, and pouch 210 has shorter channels, permitting better fluid flow and minimizing reagent loss in channels.

[0090] In one illustrative embodiment of FIG. 6, a 300 μ l mixture comprising the sample to be tested (100 μ l) and lysis buffer (200 μ l) is injected into injection port 241a. Water is also injected into the fitment 290 via seal 239b, hydrating up to eleven different reagents, each of which were previously provided in dry form in chambers 292b through 292l via channel 293 (shown in shadow). These reagents illustratively may include freeze-dried PCR reagents, DNA extraction reagents, wash solutions, immunoassay reagents, or other chemical entities. For the example of FIG. 6, the reagents are for nucleic acid extraction, first-stage multiplex PCR, dilution of the multiplex reaction, and preparation of second-stage PCR reagents, and control reactions. In the embodiment shown in FIG. 6, all that need be injected is the sample in port 241a and water in port 241b.

[0091] As shown in FIG. 6, water injected via seal 293b is distributed to various chambers via channel 293. In this embodiment, only the sample and water need be injected into pouch 210. It is understood, however, that water could be injected into each chamber 292 independently. Further, it is understood that, rather than providing dried reagents in the various chambers 292 and hydrating upon injection of the water, specific wet reagents could be injected into each chamber, as desired. Additionally, it is understood that one or more of chambers 292 could be provided with water only, and the necessary reagents may be provided dried in the appropriate reaction blisters. Various combinations of the above, as dictated by the needs of the particular reaction, are within the scope of this invention.

[0092] As seen in FIG. 6, optional protrusions 213 are provided on bottom surface 297 of fitment 290. As shown, protrusions 213 are located within their respective entry channels 215. However, other configurations are possible. Protrusions 213 assist in opening entry channel 215 and prevent bottom surface 297 from engaging another flat surface in such a way to pinch off entry channels 215 when plungers 268 are depressed, which helps prevent back-flow upon activation of the plungers 268. Such protrusions may be used on any of the various pouches according to the present invention. In embodiments wherein water is injected into the pouch to hydrate multiple dry reagents in multiple chambers in the fitment, a means of closing the channel between the injection port and the many chambers is desired. If the channel is not closed, activation of each plunger may force some of the contents of its respective chamber back out into the channel, potentially contaminating neighboring chambers and altering the volumes contained in and delivered from the chamber. Several ways of closing this channel have been used, including rotating a notched plunger 268 as discussed above, and heat-sealing the plastic film across the channel thereby closing the channel permanently, and applying pressure to the channel as a pinch valve. Other closures may also be used, such as valves built into the fitment, illustratively one-way valves.

[0093] After the fluids are loaded into chambers 292 and pouch 210 is loaded into the instrument, plunger 268a is depressed illustratively via activation of a pneumatic piston, forcing the balance of the sample into three-lobed blister 220 via channel 214. As with the embodiments shown in FIGS. 1 and 5, the lobes 224, 226, and 228 of three-lobed blister 220 are sequentially compressed via action bladders 824, 826, and

828 of bladder assembly **810**, shown in FIGS. 7-9, forcing the liquid through the narrow nexus **232** between the lobes, and driving high velocity collisions, shearing the sample and liberating nucleic acids, illustratively including nucleic acids from hard-to-open spores, bacteria, and fungi. Cell lysis continues for an appropriate length of time, illustratively 0.5 to 10 minutes.

[0094] Once the cells have been adequately lysed, plunger **268b** is activated and nucleic acid binding magnetic beads stored in chamber **292b** are injected via channel **236** into upper lobe **228** of three-lobed blister **220**. The sample is mixed with the magnetic beads and the mixture is allowed to incubate for an appropriate length of time, illustratively approximately 10 seconds to 10 minutes.

[0095] The mixture of sample and beads are forced through channel **238** into blister **244** via action of bladder **826**, then through channel **243** and into blister **246** via action of bladder **844**, where a retractable magnet **850** located in instrument **800** adjacent blister **245**, shown in FIG. 8, captures the magnetic beads from the solution, forming a pellet against the interior surface of blister **246**. A pneumatic bladder **846**, positioned over blister **246** then forces the liquid out of blister **246** and back through blister **244** and into blister **222**, which is now used as a waste receptacle. However, as discussed above with respect to FIG. 5, other waste receptacles are within the scope of this invention. One of plungers **268c**, **268d**, and **268e** may be activated to provide a wash solution to blister **244** via channel **245**, and then to blister **246** via channel **243**. Optionally, the magnet **850** is retracted and the magnetic beads are washed by moving the beads back and forth from blisters **244** and **246** via channel **243**, by alternatively pressurizing bladders **844** and **846**. Once the magnetic beads are washed, the magnetic beads are recaptured in blister **246** by activation of magnet **850**, and the wash solution is then moved to blister **222**. This process may be repeated as necessary to wash the lysis buffer and sample debris from the nucleic acid-binding magnetic beads. Illustratively, three washes are done, one each using wash reagents in chambers **292c**, **292d**, and **292e**. However, it is understood that more or fewer washes are within the scope of this invention. If more washes are desired, more chambers **292** may be provided. Alternatively, each chamber **292** may hold a larger volume of fluid and activation of the plungers may force only a fraction of the volume from the chamber upon each activation.

[0096] After washing, elution buffer stored in chamber **292f** is moved via channel **247** to blister **248**, and the magnet is retracted. The solution is cycled between blisters **246** and **248** via channel **252**, breaking up the pellet of magnetic beads in blister **246** and allowing the captured nucleic acids to dissociate from the beads and come into solution. The magnet **850** is once again activated, capturing the magnetic beads in blister **246**, and the eluted nucleic acid solution is forced into blister **248**.

[0097] Plunger **268h** is depressed and first-stage PCR master mix from chamber **292h** is mixed with the nucleic acid sample in blister **248**. Optionally, the mixture is mixed by alternative activation of bladders **848** and **864**, forcing the mixture between **248** and **264** via channel **253**. After several cycles of mixing, the solution is contained in blister **264**, where first-stage multiplex PCR is performed. If desired, prior to mixing, the sample may be retained in blister **246** while the first-stage PCR master mix is pre-heated, illustratively by moving the first-stage PCR master mix into blister **264** or by providing a heater adjacent blister **248**. As dis-

cussed above, this pre-heating may provide the benefits of hot start PCR. The instrument **800** illustrated in FIG. 8 features Peltier-based thermal cyclers **886** and **888** which heat and cool the sample. However, it is understood that other heater/cooler devices may be used, as discussed above. Optionally, mixing between blisters **248** and **264** may continue during temperature cycling, with thermal cycler **886** positioned to heat and cool both blisters **248** and **264**. It has been found that such mixing improves the first-stage PCR reaction in some embodiments. Also, thermal cycling can be accomplished by varying the temperatures in two or more different blisters, allowing minimal energy expenditure and maximizing thermal cycling speed. For example the temperature can be maintained at 95° C. in blister **248**, and 65° C. blister **264**, and moving the sample between these blisters effectively transfers heat into and out of the sample, allowing rapid and accurate thermal cycling. Temperature cycling is illustratively performed for 15-20 cycles, although other levels of amplification may be desirable, depending on the application, as discussed above. As will be seen below, the second-stage amplification zone **280** is configured to detect amplification in **18** second-stage reactions. Accordingly, **18** different primer-pairs may be included in the PCR reaction in blister **264**.

[0098] In an alternative hot start method, pouch **210** is manufactured with the primers provided in one of the blisters, illustratively blister **264**. In one embodiment, the primers are freeze dried separately and then introduced during manufacture into blister **264** as a friable pellet. Prior to first-stage PCR, illustratively the sample is eluted from blister **246** and pushed to blister **264** to rehydrate the primer pellet. Peltier **886**, which is positioned adjacent blisters **248** and **264** is heated to 48° C., and PCR master mix is pushed to blister **248**. After a hold, illustratively for 10 seconds, during which the two blisters reach 48° C., mixing between blisters **248** and **264** begins. Thus, the enzymes and dNTPs remain in blister **248** and most of the sample and the primers remain in blister **264** until the components separately have reached 48° C. It is understood, however, that the choice of 48° C. was made for use with concurrent first-stage amplification and RT using AMV, which is active up to 50° C. If RT is not needed or a more thermostable RT enzyme is used, then one or both of the two blisters **248** and **264** may be heated up to 58° C., or even higher, depending on the primer melting temperature or other factors in a particular first-stage amplification protocol. It is understood that this hot start method may be used with any embodiment of the present invention.

[0099] In an alternative embodiment, to reduce the complexity of the first-stage PCR reaction, blister **248** may be divided into two or more blisters. It is believed that the number of nonspecific products of a multiplex reaction goes up as the square (or possibly higher power) of the number of primers in the mixture, while the loss of sensitivity of an assay is a linear function of the amount of input sample. Thus, for example, splitting the first stage PCR into two reactions, each of half the volume of the single reaction of this embodiment, would reduce sensitivity by two-fold but the quantity and complexity of the nonspecific reactions would be ¼ as much. If blister **248** is divided into or more blisters, blister **264** may be divided into a number of blisters equal to the number of blisters **248**. Each respective blister **248** would be connected to its respective blister **264** via a respective channel **253**. Each blister **264** would be provided with a pellet comprising a subset of all primers. Sample from blister **246** would be

divided across each blister 248, each blister 248 would be sealed from all others, and thermal cycling would proceed with each pair of blisters 248 and 264, as described above. After thermal cycling, the sample would be recombined into blister 266 or individually sent to separate sets of second-stage blisters.

[0100] After first-stage PCR has proceeded for the desired number of cycles, the sample may be diluted as discussed above with respect to the embodiment of FIG. 5, by forcing most of the sample back into blister 248, leaving only a small amount, and adding second-stage PCR master mix from chamber 292i. Alternatively, a dilution buffer from 292i may be moved to blister 266 via channel 249 and then mixed with the amplified sample in blister 264 by moving the fluids back and forth between blisters 264 and 266. After mixing, a portion of the diluted sample remaining in blister 264 is forced away to three-lobed blister 222, now the waste receptacle. If desired, dilution may be repeated several times, using dilution buffer from chambers 292j and 292k, and then adding second-stage PCR master mix from chamber 292g to some or all of the diluted amplified sample. It is understood that the level of dilution may be adjusted by altering the number of dilution steps or by altering the percentage of the sample discarded prior to mixing with the dilution buffer or second-stage PCR master mix.

[0101] If desired, this mixture of the sample and second-stage PCR master mix may be pre-heated in blister 264 prior to movement to second-stage blisters 282 for second-stage amplification. As discussed above, such preheating may obviate the need for a hot-start component (antibody, chemical, or otherwise) in the second-stage PCR mixture.

[0102] The illustrative second-stage PCR master mix is incomplete, lacking primer pairs, and each of the 18 second-stage blisters 282 is pre-loaded with a specific PCR primer pair. If desired, second-stage PCR master mix may lack other reaction components, and these components may then be pre-loaded in the second-stage blisters 282 as well. As discussed above with the prior examples, each primer pair may be identical to a first-stage PCR primer pair or may be nested within the first-stage primer pair. Movement of the sample from blister 264 to the second-stage blisters completes the PCR reaction mixture. Control samples from chamber 2921 are also moved to control blisters 283 via channel 267. The control samples may be positive or negative controls, as desired. Illustratively, each pouch would contain control reactions that validate the operation of each step in the process and demonstrate that positive results are not the result of self-contamination with previously amplified nucleic acids. However, this is not practical in many protocols, particularly for a highly multiplexed reaction. One illustrative way of providing suitable controls involves spiking samples with a species such as baker's yeast. The nucleic acids are extracted from the yeast, alongside other nucleic acids. First- and second-stage PCR reactions amplify DNA and/or RNA targets from the yeast genome. Illustratively, an mRNA sequence derived from a spliced pre-mRNA can be used to generate an RNA-specific target sequence by arranging the primer sequences to span an intron. A quantitative analysis of the yeast copy number against reference standards allows substantial validation that each component of the system is working. Negative control reactions for each of the many second-stage assays are more problematic. It may be desirable to run control reactions either in parallel or in a separate run.

[0103] Activation of bladder 882 of bladder assembly 810 seals the samples into their respective second-stage blisters 282, 283, and activation of bladder 880 provides gentle pressure on second-stage blisters 282, 283, to force second-stage blisters 282, 283 into contact with a heater/cooler device. A window 847 positioned over the second-stage amplification zone 280 allows fluorescence monitoring of the array during PCR and during a DNA melting-curve analysis of the reaction products.

[0104] It is noted that the pouch 210 of FIG. 6 has several unsealed areas, such as unsealed area 255 and unsealed area 256. These unsealed areas form blisters that are not involved in any of the reactions in this illustrative embodiment. Rather, these unsealed areas are provided in space between the working blisters and channels. In some manufacturing processes, as compared to pouches that are sealed in all unused space, it has been found that fewer leaks sometimes result when unsealed areas such as 255 and 256 are provided, presumably by reducing problematic wrinkles in the film material. Such unsealed areas optionally may be provided on any pouch embodiment.

[0105] FIG. 8 shows an illustrative apparatus 800 that could be used with pouch 210. Instrument 800 includes a support member 802 that could form a wall of a casing or be mounted within a casing. Instrument 800 also includes a second support member 804 that is optionally movable with respect to support member 802, to allow insertion and withdrawal of pouch 210. Movable support member 804 may be mounted on a track or may be moved relative to support member 802 in any of a variety of ways. Illustratively, a lid 805 fits over pouch 210 once pouch 210 has been inserted into instrument 800. In another embodiment, both support members 802 and 804 may be fixed, with pouch 210 held into place by other mechanical means or by pneumatic pressure.

[0106] Illustratively, the bladder assembly 810 and pneumatic valve assembly 808 are mounted on movable member 802, while the heaters 886 and 888 are mounted on support member 802. However, it is understood that this arrangement is illustrative only and that other arrangements are possible. As bladder assembly 810 and pneumatic valve assembly 808 are mounted on movable support member 804, these pneumatic actuators may be moved toward pouch 210, such that the pneumatic actuators are placed in contact with pouch 210. When pouch 210 is inserted into instrument 800 and movable support member 804 is moved toward support member 802, the various blisters of pouch 210 are in a position adjacent to the various pneumatic bladders of bladder assembly 810 and the various pneumatic pistons of pneumatic valve assembly 808, such that activation of the pneumatic actuators may force liquid from one or more of the blisters of pouch 210 or may form pinch valves with one or more channels of pouch 210. The relationship between the blisters and channels of pouch 210 and the pneumatic actuators of bladder assembly 810 and pneumatic valve assembly 808 are discussed in more detail below with respect to FIGS. 9 and 10.

[0107] Each pneumatic actuator has one or more pneumatic fittings. For example, bladder 824 of bladder assembly 810 has pneumatic fitting 824a and pneumatic piston 843 has its associated pneumatic fitting 843a. In the illustrative embodiment, each of the pneumatic fittings of bladder assembly 810 extends through a passageway 816 in movable support member 804, where a hose 878 connects each pneumatic fitting to compressed air source 895 via valves 899. In the illustrative embodiment, the passageways 816 not only provide access to

compressed air source **895**, but the passageways also aid in aligning the various components of bladder assembly **810**, so that the bladders align properly with the blisters of pouch **210**. [0108] Similarly, pneumatic valve assembly **808** is also mounted on movable support member **804**, although it is understood that other configurations are possible. In the illustrative embodiment, pins **858** on pneumatic valve assembly **808** mount in mounting openings **859** on movable support member **804**, and pneumatic pistons **843**, **852**, **853**, and **862** extend through passageways **816** in movable support member **804**, to contact pouch **210**. As illustrated, bladder assembly is mounted on a first side **811** of movable support member **804** while pneumatic valve assembly **808** is mounted on a second side **812** of movable support member **804**. However, because pneumatic pistons **843**, **852**, **853**, and **862** extend through passageways **816**, the pneumatic pistons of pneumatic valve assembly **808** and the pneumatic bladders of bladder assembly **810** work together to provide the necessary pneumatic actuators for pouch **210**.

[0109] As discussed above, each of the pneumatic actuators of bladder assembly **810** and pneumatic valve assembly **808** has an associated pneumatic fitting. While only several hoses **878** are shown in FIG. **8**, it is understood that each pneumatic fitting is connected via a hose **878** to the compressed gas source **895**. Compressed gas source **895** may be a compressor, or, alternatively, compressed gas source **895** may be a compressed gas cylinder, such as a carbon dioxide cylinder. Compressed gas cylinders are particularly useful if portability is desired. Other sources of compressed gas are within the scope of this invention.

[0110] Several other components of instrument **810** are also connected to compressed gas source **895**. Magnet **850**, which is mounted on a first side **813** of support member **802**, is illustratively deployed and retracted using gas from compressed gas source **895** via hose **878**, although other methods of moving magnet **850** are known in the art. Magnet **850** sits in recess **851** in support member **802**. It is understood that recess **851** can be a passageway through support member **802**, so that magnet **850** can contact blister **246** of pouch **210**. However, depending on the material of support member **802**, it is understood that recess **851** need not extend all the way through support member **802**, as long as when magnet **850** is deployed, magnet **850** is close enough to provide a sufficient magnetic field at blister **246**, and when magnet **850** is retracted, magnet **850** does not significantly affect any magnetic beads present in blister **246**. While reference is made to retracting magnet **850**, it is understood that an electromagnet may be used and the electromagnet may be activated and inactivated by controlling flow of electricity through the electromagnet. Thus, while this specification discusses withdrawing or retracting the magnet, it is understood that these terms are broad enough to incorporate other ways of withdrawing the magnetic field. It is understood that the pneumatic connections may be pneumatic hoses or pneumatic air manifolds, thus reducing the number of hoses or valves required.

[0111] The various pneumatic pistons **868** of pneumatic piston array **869**, which is mounted on support **802**, are also connected to compressed gas source **895** via hoses **878**. While only two hoses **878** are shown connecting pneumatic pistons **868** to compressed gas source **895**, it is understood that each of the pneumatic pistons **868** are connected to compressed gas source **895**. Twelve pneumatic pistons **868** are shown. When the pouch **210** is inserted into instrument **800**, the twelve pneumatic pistons **868** are positioned to activate their

respective twelve plungers **268** of pouch **210**. When lid **805** is closed over pouch **210**, a lip **806** on lid **805** provides a support for fitment **290**, so that as the pneumatic pistons **868** are activated, lid **805** holds fitment **290** in place. It is understood that other supports for fitment **290** are within the scope of this invention.

[0112] A pair of heating/cooling devices, illustratively Peltier heaters, are mounted on a second side **814** of support **802**. First-stage heater **886** is positioned to heat and cool the contents of blister **264** for first-stage PCR. Second-stage heater **888** is positioned to heat and cool the contents of second-stage blisters **282** and **283** of pouch **210**, for second-stage PCR. It is understood, however, that these heaters could also be used for other heating purposes, and that other heaters may be included, as appropriate for the particular application.

[0113] If desired, a feedback mechanism (not shown) may be included in instrument **800** for providing feedback regarding whether the sample has actually been forced into a particular blister. Illustrative feedback mechanisms include temperature or pressure sensors or optical detectors, particularly if a fluorescent or colored dye is included. Such feedback mechanisms illustratively may be mounted on either of support members **802** or **804**. For example, a pressure sensor may be mounted on support **802** adjacent the location of blister **264**. When the sample is supposedly moved to blister **264**, if the pressure sensor is depressed, then sample processing is allowed to continue. However, if the pressure sensor is not depressed, then sample processing may be stopped, or an error message may be displayed on screen **892**. Any combination or all of the blisters may have feedback mechanisms to provide feedback regarding proper movement of the sample through the pouch.

[0114] When fluorescent detection is desired, an optical array **890** may be provided. As shown in FIG. **8**, optical array **890** includes a light source **898**, illustratively a filtered LED light source, filtered white light, or laser illumination, and a camera **896**. A window **847** through movable support **804** provides optical array **890** with access to second-stage amplification zone **280** of pouch **210**. Camera **896** illustratively has a plurality of photodetectors each corresponding to a second-stage blister **282**, **823** in pouch **210**. Alternatively, camera **896** may take images that contain all of the second-stage blisters **282**, **283**, and the image may be divided into separate fields corresponding to each of the second-stage blisters **282**, **283**. Depending on the configuration, optical array **890** may be stationary, or optical array **890** may be placed on movers attached to one or more motors and moved to obtain signals from each individual second-stage blister **282**, **283**. It is understood that other arrangements are possible.

[0115] As shown, a computer **894** controls valves **899** of compressed air source **895**, and thus controls all of the pneumatics of instrument **800**. Computer **894** also controls heaters **886** and **888**, and optical array **890**. Each of these components is connected electrically, illustratively via cables **891**, although other physical or wireless connections are within the scope of this invention. It is understood that computer **894** may be housed within instrument **890** or may be external to instrument **890**. Further, computer **894** may include built-in circuit boards that control some or all of the components, and may also include an external computer, such as a desktop or laptop PC, to receive and display data from the optical array. An interface **893**, illustratively a keyboard interface, may be provided including keys for inputting information and variables such as temperatures, cycle times, etc. Illustratively, a

display 892 is also provided. Display 892 may be an LED, LCD, or other such display, for example.

[0116] FIG. 9 shows the relationship between bladder assembly 810 and pouch 210 during operation of instrument 800. Bladder assembly comprises sub-assemblies 815, 817, 818, 819, and 822. Because bladder 809 of bladder sub-assembly 815 is large, bladder sub-assembly 815 illustratively has two pneumatic fittings 815a and 815b. Bladder 809 is used to close off chambers 292 (as shown in FIG. 6) from the plastic film portion 217 of pouch 210. When one of the plungers 268 is depressed, one or both of pneumatic fittings 815a and 815b permit bladder 809 to deflate. After the fluid from one of the chambers 292 passes through, bladder 809 is re-pressurized, sealing off channels 214, 236, 245, 247, and 249. While illustrative bladder sub-assembly 815 has only one bladder 809, it is understood that other configurations are possible, illustratively where each of channels 214, 236, 245, 247, and 249 has its own associated bladder or pneumatic piston. Bladder sub-assembly 822 illustratively comprises three bladders 824, 826, and 828. As discussed above, bladders 824, 824, and 828 drive the three-lobed blister 222 for cell lysis. As illustrated, bladders 824, 826, and 828 are slightly larger than their corresponding blisters 224, 226, 228. It has been found that, upon inflation, the surface of the bladders can become somewhat dome-shaped, and using slightly oversized bladders allows for good contact over the entire surface of the corresponding blister, enabling more uniform pressure and better evacuation of the blister. However, in some circumstances, complete evacuation of individual blisters may or may not be desired, and larger or smaller-sized bladders may be used to control the blister volume evacuated. Bladder sub-assembly 817 has four bladders. Bladder 836 functions as a pinch-valve for channel 236, while bladders 844, 848, and 866 are configured to provide pressure on blisters 244, 248, and 266, respectively. Bladder sub-assembly 818 has two bladders 846 and 864, which are configured to provide pressure on blisters 246 and 264, respectively. Finally, bladder sub-assembly 819 controls second-stage amplification zone 280. Bladder 865 acts as a pinch valve for channels 265 and 267, while bladder 882 provides gentle pressure to second-stage blisters 282 and 283, to force second-stage blisters into close contact with heater 888. While bladder assembly 810 is provided with five sub-assemblies, it is understood that this configuration is illustrative only and that any number of sub-assemblies could be used or that bladder assembly 810 could be provided as a single integral assembly.

[0117] FIG. 10 similarly shows the relationship between pneumatic valve assembly 808 and pouch 210 during operation of instrument 800. Rather than bladders, pneumatic valve assembly 808 has four pneumatic pistons 842, 852, 853, and 862. These pneumatic pistons 842, 852, 853, and 862, each driven by compressed air, provide directed pressure on channels 242, 252, 253, and 262. Because the pistons are fairly narrow in diameter, they can fit between bladder sub-assembly 817 and bladder sub-assembly 818 to provide pinch valves for channels 242, 252, 253, and 262, allowing channels 242, 252, 253, and 262 to be fairly short. However, if desired, pneumatic pistons 842, 852, 853, and 862 could be replaced by bladders, which may be included in bladder assembly 810, obviating the need for pneumatic valve assembly 808. It is understood that any combination of bladders and pneumatic pistons are within the scope of this invention. It is also understood that other methods of providing pressure on the chan-

nels and blisters of pouch 210, as are known in the art, are within the scope of this invention.

[0118] FIG. 12 shows a pouch 510 that is similar to pouch 210 of FIG. 6. Fitment 590, with entry channels 515a through 515l, is similar to fitment 290, with entry channels 215a through 215l. Blisters 544, 546, 548, 564, and 566, with their respective channels 538, 543, 552, 553, 562, and 565 are similar to blisters 244, 246, 248, 264, and 266, with their respective channels 238, 243, 252, 253, 262, and 265 of pouch 210. The channels 245, 247, and 249 of pouch 210 have been somewhat reconfigured as channels 545a-c, 547a-b, and 548a-c on pouch 510; the respective channels of 510 are somewhat shorter than their counterpart channels on pouch 210. However, it is understood that channel configurations are illustrative only, and that various channel configurations are within the scope of this invention.

[0119] There are two main differences between pouch 510 of FIG. 12 and pouch 210 of FIG. 6. First, three-lobed blister 222 has been replaced by lysis blister 522. Lysis blister 522 is configured for vortexing via impaction using rotating blades or paddles 21 attached to electric motor 19, as shown in FIG. 2b. Since this method of lysing does not rely on alternating pressure of pneumatic pistons, only a single-lobed blister is shown. Because lysis blister 522 has only a single lobe, both channels 514 and 536 lead to the single lobe of lysis blister 522. It is understood that lysis blister 522 may be used in any of the pouch embodiments described herein. It is further understood that lysis assembly 810 illustratively may be modified to replace bladders 824, 826, and 828 of bladder sub-assembly 822 with a single bladder configured for blister 522. Conversely, a three-lobed blister, as described in various other embodiments above, may be used in pouch 510. Lysis blister 522 may be provided with an optional reinforcing patch 523, illustratively attached using adhesive or lamination to the exterior surface of lysis blister 522. Reinforcing patch 523 aids in minimizing tearing of pouch 510 due to repeated contact by paddles 21. FIG. 13 shows an electric motor, illustratively a Mabuchi RC-280SA-2865 DC Motor (Chiba, Japan), mounted on second support member 804. In one illustrative embodiment, the motor is turned at 5,000 to 25,000 rpm, more illustratively 10,000 to 20,000 rpm, and still more illustratively approximately 15,000 to 18,000 rpm. For the Mabuchi motor, it has been found that 7.2V provides sufficient rpm for lysis. It is understood, however, that the actual speed may be somewhat slower when the blades 21 are impacting pouch 510. Other voltages and speeds may be used for lysis depending on the motor and paddles used. Optionally, controlled small volumes of air may be provided into the bladder adjacent lysis blister 522. It has been found that in some embodiments, partially filling the adjacent bladder with one or more small volumes of air aids in positioning and supporting lysis blister during the lysis process. Alternatively, other structure, illustratively a rigid or compliant gasket or other retaining structure around lysis blister 522, can be used to restrain pouch 510 during lysis.

[0120] The second main difference between pouch 510 of FIG. 12 and pouch 210 of FIG. 6 is that the blisters 281, 282, and 283 of second-stage amplification zone 280 have been replaced by high density array 581 in second-stage amplification zone 580. High density array 581 comprises a plurality of second-stage wells 582, illustratively 50 or more wells, and even more illustratively 120 or more wells. Embodiments with more second-stage wells 582, illustratively about 200, about 400, or even about 500 or more are within the scope of

this invention. Other configurations are within the scope of this invention as well. Additional second-stage wells **582** may be added by making wells **582** smaller, by making high density array **581** larger, or a combination thereof. For second-stage PCR, each of the wells may contain a pair of primers. It is understood that one or more wells may be used for positive or negative controls.

[0121] Cross-contamination between wells as the wells are filled with the diluted first-stage amplification product in blister **566** can be a major problem. Cross-contamination was controlled in pouch **210** by filling each second-stage blister through a separate branch of channel **265** and then sealing with bladder **882**, illustrated in FIG. 9. With high density array **581**, wherein fluid may fill some or all of blister **584**, cross-contamination between wells must also be controlled. In one embodiment, the second-stage PCR primers may be bound covalently or non-covalently to the inside surface of each well, thus functioning much like a

[0122] PCR chip. However, in many embodiments it is desirable to control cross-contamination between wells without tethering the PCR primers to the wells. Controlling cross-contamination between wells can be difficult in an embodiment wherein the fluid from blister **566** is moved to wells **582** by flowing across a first surface **581a** of high density array **581**. There are several desirable features for successful loading of the second-stage amplification zone **580**. First, it is desirable that the incoming fluid from blister **566** fill substantially all of the wells **582** to substantially the same level. An unfilled well would produce a false negative signal. Second, it is desirable that the process of filling the wells **582** should not cause the primers in the well to leak out. Loss of primers from one well can limit the efficiency of the PCR reaction in that well and can contaminate neighboring wells. Third, after the wells **582** have been filled and PCR started, it is desirable that the wells be completely sealed from each other. Amplicon leakage out of one well and into another well can lower signal in the first well and raise signal in the second well, potentially leading to a false negative in the first well and a false positive in the second well. Further, for certain kinds of controls, it is important that amplicon generated in one well not enter another well where it can be further amplified.

[0123] Solutions to this problem include use of a barrier layer. In one example, the barrier layer is a physical barrier that is provided to allow for rapid loading of the wells and for rapid sealing from the bulk fluid. In another example, combined chemical and physical barriers are used, wherein the physical barrier is used to seal the wells and then the chemical barrier conditionally releases the oligonucleotide primers into the well solution, for example by heating, slow release, or enzymatic digestion. Well depth or channel length to each well also may be used to control release of the reagents from the wells. Other means for loading high density array **581** are possible.

[0124] FIG. 14 shows an illustrative embodiment of second-stage **580** using a physical barrier. Sandwiched between first layer **518** and second layer **519** of pouch **510** is high density array **581**, with wells **582**. Pierced layer **585**, with piercings **586**, is provided on one side of high density array **581** to act as the physical barrier, and a second layer **587**, is provided on the opposite side of high density array **581** to form the bottom of wells **582**. Illustratively, pierced layer **585** and second layer **587** are plastic films that have been sealed to high density array **581**, illustratively by heat sealing, although it is understood that other methods of sealing may be

employed. It is also understood that the material used for high density array **581** and the material used for pierced layer **585** and second layer **587** should be compatible with each other, with the sealing method, and with the chemistry being used. When used for PCR, examples of compatible plastics that can be used for high density array **581** and can be heat-sealed are PE, PP, Monprene®, and other block copolymer elastomers. If fluorescent dyes are used in the detection chemistry, it may be desirable for high density array **581** to be formed from black or other relatively fluorescently opaque materials, to minimize signal bleed from one well **582** to its neighboring wells and for at least one of layers **585** and **587** to be relatively fluorescently transparent. For pierced layer **585** and second layer **587**, laminates of a strong engineering plastic such as Mylar® or PET with heat-sealable plastic layers such as PE, PP and Dupont Surlyn® may be used. For adhesive-based systems, rigid engineering plastics such as PET or polycarbonate may be used to form high density array **581** and films of PCR-compatible plastics are then used as pierced layer **585** and second layer **587**. In one illustrative embodiment, high density array **581** is formed of black PE, a composite polyethylene/PET laminate (or Xerox® PN 104702 hot laminating pouch material) is used for pierced layer **585** and second layer **587** which are heat sealed to high density array **581**, and composite polypropylene/PET is used for first and second layers **518**, **519** of pouch **510**.

[0125] It is understood that piercings **586** align with wells **582**. It is also understood that piercings **586** are small enough that, absent some force, fluid does not readily flow through piercings **586**. Illustrative piercings may be 0.001-0.1 mm, more illustratively 0.005-0.02 mm, and more illustratively about 0.01 mm. In the illustrative embodiment, second-stage amplification zone **580** is provided under vacuum, such that when fluid is received from blister **566**, the vacuum draws fluid through piercings **586** into each well **582**. Once the wells **582** are filled, a force is no longer present to force fluid into or out of the wells **582**. A bladder adjacent second-stage amplification zone **580** (not shown, but similar in position to bladders **880/882**) may then be activated to press first layer **518** against high density array **581** and seal fluid into the wells **582**. While first layer **518** of pouch **510** is used to seal the wells **582**, it is understood that an optional sealing layer may be provided between pierced layer **585** and first layer **518**.

[0126] In one illustrative example, second-stage amplification zone **580** may be prepared as follows. High density array **581** may be prepared by first punching, molding, or otherwise forming an array of wells **582** in a plastic sheet (illustratively 0.1 to 1 mm thick). The wells may form any regular or irregular array that is desired, and may have a volume illustratively of 0.05 μl to 20 μl , and more illustratively of 0.1 μl to 4 μl . One of layers **585** or **587** is then laminated to a first surface **581a** of high density array **581**, illustratively by heat or adhesive. As shown in FIG. 15, pierced layer **585** is applied to first surface **581a**. Reagents **589**, illustratively elements of the chemistry of the array that are unique, such as PCR primer pairs, are then spotted into the wells either manually by pipetting, or automatically (illustratively using x/y positionable spotters such as pin-spotters, dot-matrix printers, small-volume automatic pipettes, or micro-fluidic micro-contact spotters). Illustrative devices for spotting the reagents are discussed below in Example 4. After the reagents **589** have been dried in each well **582**, the second of layers **585** or **587** is applied to the second surface **581b** of array **581**. Layer **585** is pierced using an array of small diameter needles to form

piercings 586. Piercings 586 may be formed either before or after layer 585 has been fixed to array 581. It is understood that spotting can be done on either layer 585 before or after piercing or on layer 587. Spotting an array with holes pierced has not shown to leak substantially and offers the advantage that the needles used for piercing are not contaminated by touching the spotted reagents. Alternatively, to minimize the possibility of leakage, and to position the spotted reagents at the most distant location in the array, it may be desirable to spot the reagents 589 onto second layer 587, seal the array 581 with layer 585, and then pierce layer 585. In an illustrative example, reagents are spotted onto second layer 587 using a GeSiM A060-324 Nano-Plotter 2.1/E (Grosserkmannsdorf, Germany) or a spotter discussed below in Example 4. Using such a spotter, multiple arrays may be spotted simultaneously.

[0127] Once spotted and pierced, array 581 is placed inside layers 518 and 519 of pouch 510 and sealed in place, illustratively by heat sealing, using an adhesive, ultrasonically welding, mechanical closure, or other means of enclosing array 581 inside pouch 510 within blister 584. It is understood that blister 584 is fluidly connected to blister 566 via channel 565, and that liquid can flow from channel 565 into blister 584 and over piercings 586. In one illustrative example, when blister 584 is formed, care is taken to allow a path for air to escape. This can be accomplished by “waffling” the inside surface of first layer 518 adjacent to second-stage amplification zone 580 to imprint the film material with a pattern of slightly raised texture. This allows air and liquid to pass along the surface of pierced layer 585, and better allows liquid to reach and fill all of wells 582. The pouch 510 is then placed inside a vacuum chamber and evacuated. Illustratively, when the pressure has reached approximately 0.3 millibars, a pneumatic cylinder inside the vacuum chamber is actuated, driving down a plunger into fitment 590 to seal channel 567, thereby cutting the path from the array inside the sealed pouch, and the vacuum chamber. A plurality of other plungers are also driven into fitment 590 to seal the various entry channels 515. The pouch is removed from the vacuum chamber and may be packaged for long-term storage in a vacuum-bag.

[0128] Pouch 510 may be used in a manner similar to pouch 210. Because array 581 is packaged in vacuum, when liquid is moved from blister 566 to second-stage amplification zone 580, the liquid sample is drawn through piercings 586 and into wells 582. Excess liquid is forced away by inflating a pneumatic bladder over the array and thermal cycling is accomplished as described above, illustratively by heating and cooling a Peltier element pressed against one side of the array.

[0129] As mentioned above, pierced layer 585 may be replaced by a variety of suitable physical or chemical barriers. In one illustrative embodiment using a chemical barrier, pierced layer 585 is omitted, and reagents 589 are spotted into wells 582 in a buffer that dissolves relatively slowly. Illustratively, reagents 589 that contain polymers such as PEG, Ficoll or polysorbate 20 or sugars such as sucrose, trehalose or mannitol in appropriate concentrations will be compatible with the second-stage PCR reaction and may dissolve more slowly than primers spotted solely in water or Tris/EDTA. The primers spotted in one of these buffers may be air dried into the wells 582, as described above (it is understood that in such an embodiment, second layer 587 is affixed to high density array 581 for spotting). These same polymers may be used in lyophilization of enzyme reagents (e.g. the enzymes

and buffers used in PCR) to form an open matrix containing the stabilized enzymes. Thus, the primers spotted in these buffers can be lyophilized in place in the wells 582, leading to slower but potentially more complete rehydration than with air drying. When pouch 510 is used, the fluid from blister 566 is driven into the well by vacuum or pressure and starts to dissolve the primer mix. By selecting a buffer that dissolves suitably slowly, when the bladder adjacent second-stage amplification zone 580 is actuated, the contents of each well 582 is sealed therein prior to any substantial cross-contamination.

[0130] Another embodiment uses a matrix that does not dissolve until second-stage amplification zone 580 is heated above a predetermined temperature. One example of such a matrix is low melt agarose such as GenePure LowMelt Agarose (ISC Bioexpress). In one example, a 1.5% solution of this agarose melts at 65° C. and gels at 24-28° C. Prior to spotting, reagents 589 illustratively may be warmed to 50° C. and mixed with this agarose that had already been melted and then spotted into wells 582 in a small volume (illustratively 100 to 500 nL). To keep the mixture liquid during spotting, this may have to be done in a cabinet heated above the melting temperature of the agarose. Alternatively, it may be possible to pipette dilute solutions of the agarose without melting. After the agarose/reagent mixture is spotted, the high density array 581 is dried. This can be a simple air drying or the primer-agarose mixture can contain the sugars and polymers listed above so that the reagents can be freeze dried. When pouch 510 is used for PCR, second-stage amplification zone 580 may be heated, illustratively to 55° C., as the fluid from blister 566 is moved into high density array 581. At this temperature, the agarose does not melt so the primers are not released into solution. Once high density array 581 is filled, the corresponding bladder is inflated to seal the wells. When the temperature rises above 65° C. in the first denaturation step of the first PCR cycle, the agarose containing the primers melts, releasing the primers into the master mix. Illustratively, thermal cycling never goes below 60° C. (or other melting temperature for the agarose) so that the agarose does not gel during thermal cycling. Furthermore, in the illustrative instrument 800 of FIG. 8, the repeated temperature cycling is driven by heater 888, which is located on one side of the pouch. It is expected that there will often be a temperature gradient across the PCR solution in wells 582, which should facilitate mixing of the primers by convective fluid flow. Wax may also be used in a similar embodiment.

[0131] In a further embodiment, the primers may be conditionally bound to the wells 581, with subsequent releasing of the primers into solution after the wells 581 have been filled. Depending upon how the primers are attached to the plastic substrate, the primers may be cleaved using heat (illustratively during the first cycle of the PCR reaction), light (illustratively irradiating through window 847), chemicals (e.g. dithiothreitol together with heat will reduce disulfide bonds that may be used to link primers to the wells), or enzymes (e.g. site specific proteases such as Tissue Plasminogen Activator can be used to cleave the proper peptide linker attaching primers to the substrate).

[0132] In yet another embodiment, a DNase may be injected into second-stage amplification zone 580 subsequent to amplification, to minimize further any potential risk of contamination.

[0133] It is understood that second-stage amplification zone 580 has been described herein for use with PCR. How-

ever, other uses for pouch **510** and second-stage amplification zone **580** are within the scope of this invention. Further, it is understood that second-stage amplification zone **580** may be used with or without nucleic acid extraction and a first stage PCR amplification zone. Finally, it is understood that second-stage amplification zone **580** may be used with any of the pouch embodiments described herein.

EXAMPLE 1

Nested Multiplex PCR

[0134] A set of reactions was run in a pouch **110** of FIG. 5, on an instrument similar to instrument **800** but configured for pouch **110**. To show cell lysis and effectiveness of the two-stage nucleic acid amplification, 50 μ L each of a live culture of *S. cerevisiae* and *S. pombe* at log phase was mixed with 100 μ L of a nasopharyngeal aspirate sample from a healthy donor to form the sample, then mixed with 200 μ L lysis buffer (6M guanidine-HCl, 15% TritonX 100, 3M sodium acetate. 300 μ L of the 400 μ L sample in lysis buffer was then injected into chamber **192a** of pouch **110**.

[0135] The pouch **110** was manufactured with 0.25 g ZS beads sealed in three-lobed blister **122**. Second-stage primers, as discussed below, were also spotted in blisters **181** and **182** during manufacture of pouch **110**. The pouch **110** was loaded as follows:

[0136] **115a** sample and lysis buffer, as described above,

[0137] **115b** magnetic beads in the lysis buffer,

[0138] **115d-e** wash buffer (10 mM sodium citrate),

[0139] **115g** elution buffer (10 mM Tris, 0.1 mM EDTA)

[0140] **115h** first-stage PCR buffer:

[0141] 0.2 mM dNTPs

[0142] 0.3 μ M each primer:

[0143] Sc1: primers configured for amplifying a portion of the YRA1 nuclear protein that binds to RNA and to MEX67p of *S. cerevisiae*. The primers are configured to amplify across an intron such that amplification of cDNA (mRNA reverse-transcribed via M-MLV) yields a 180 by amplicon.

[0144] Sc2: primers configured for amplifying a 121 by region of the cDNA of MRK1 glycogen synthase kinase 3 (GSK-3) homolog of *S. cerevisiae*.

[0145] Sc3: primers configured for amplifying a 213 by region of the cDNA of RUB1 ubiquitin-like protein of *S. cerevisiae*.

[0146] Sp1: primers configured for amplifying a 200 by region of the cDNA of sucl-cyclin-dependent protein kinase regulatory subunit of *S. pombe*.

[0147] Sp2: primers configured for amplifying a 180 by region of the cDNA of sec14-cytosolic factor family of *S. pombe*.

[0148] PCR buffer with 3 mM MgCl₂ (without BSA)

[0149] 50 units M-MLV

[0150] 4.5 units Taq:Antibody

[0151] 100 units RNaseOut

[0152] **115j-k** second-stage PCR buffer

[0153] 0.2 mM dNTPs

[0154] 1X LC Green® Plus (Idaho Technology)

[0155] PCR buffer with 2 mM MgCl₂ (with BSA),

[0156] 4.5 units Taq

[0157] **115l** second-stage PCR buffer with a sample of the first-stage amplicons.

[0158] During manufacture, second-stage blisters **181** and **182** were spotted with nested second-stage primers. Each

blister was spotted with one primer pair in an amount to result in a final concentration of about 0.3 μ M once rehydrated with the second-stage PCR buffer. The second-stage nested primers are as follows:

[0159] Sc1: primers configured for amplifying an 80 by fragment of the Scl cDNA first-stage amplicon.

[0160] Sc2: primers configured for amplifying a 121 by fragment of the Scl cDNA first-stage amplicon.

[0161] Sc3: primers configured for amplifying a 93 by portion of the Scl cDNA first-stage amplicon.

[0162] Sp1: primers configured for amplifying a 99 by portion of the Scl cDNA first-stage amplicon.

[0163] Sp2: primers configured for amplifying a 96 by portion of the Scl cDNA first-stage amplicon.

There is no overlap between the first-stage and second stage primer pairs for any of the targets. Each pair of primers was spotted into one negative control blister **181** and two second-stage blisters **182**, so that each second-stage amplification would be run in duplicate, each duplicate with a negative control.

[0164] After loading, activation of the plunger associated with entry channel **115a** moved the sample to three-lobed blister **122**, activation of the plunger associated with entry channel **115b** moved the magnetic beads to reservoir **101**, activation of the plungers associated with entry channels **115d-e** moved wash buffer to reservoirs **102** and **103**, activation of the plunger associated with entry channel **115g** moved elution buffer to reservoir **104**, activation of the plunger associated with entry channel **115h** moved first-stage PCR buffer to reservoir **105**, activation of the plungers associated with entry channels **115j-k** moved second stage PCR buffer to reservoirs **106** and **107**, and activation of the plunger associated with entry channel **115l** moved the positive control (second-stage PCR buffer with a sample of previously prepared first-stage amplicon) to reservoir **108**. In this present example, the plungers associated with entry channels **115a** and **115b** were depressed prior to loading the pouch **110** into the instrument. All other plungers were depressed sequentially in the instrument during the run, and fluids were moved to reservoirs **102** through **108** as needed.

[0165] Once pouch **110** was placed into the instrument, and beating took place for ten minutes in the presence of ZS beads, as described above. Once cell lysis was complete, reservoir **101** was compressed and nucleic acid binding magnetic beads from reservoir **101** were forced into three-lobed blister **122**, where the beads were mixed gently and allowed to incubate for 5 minutes.

[0166] The sample-bead mixture was then moved to blister **144**, where the magnetic beads were captured via activation of the magnet. Once the magnet was deployed, bladders adjacent blister **144** were pressurized to force fluids back to three-lobed blister **122**. The captured beads were then washed as described above, using the wash solution from reservoirs **102** and **103**. Following washing, the beads were once again captured in blister **144** via activation of the magnet, and the elution buffer stored in reservoir **104** is moved to blister **144**, where, after a 2 minute incubation, the nucleic acids eluted from the beads are then moved to blister **161**, as discussed above.

[0167] In blister **161**, the nucleic acid sample is mixed with first-stage PCR master mix from reservoir **105**. The sample is then held at 40° C. for 10 minutes (during which time M-MLV converts mRNA to cDNA), then 94° C. for 2 minutes (to

inactivate the M-MLV and remove antibody from taq). Thermal cycling is then 20 cycles of 94° C. for 10 second and 65° C. for 20 seconds.

[0168] Subsequent to first-stage amplification, the sample is diluted approximately 100-fold using the second-stage PCR master mix from reservoir **106**. The sample is then moved to blisters **182**, which were previously spotted with the second-stage primers, as discussed above. Second-stage PCR buffer was moved from reservoir **181** to negative control blisters **181**, and the positive control mixture was moved to blisters **183** from reservoir **108**. The samples were denatured for 30 seconds at 94° C., then amplified for 45 cycles of 94° C. for 5 seconds and 69° C. for 20 seconds.

[0169] As can be seen in FIG. **11**, all target amplicons and the positive control showed amplification, while none of the negative controls showed amplification. Each sample was run in replicates. The replicates each showed similar amplification (data not shown). It is understood that the *S. cerevisiae* and *S. pombe* targets are illustrative only and that other targets are within the scope of this invention.

EXAMPLE 2

High Density PCR

[0170] The above example uses pouch **110** of FIG. **5**. Pouch **110** has five negative control blisters **181**, five positive control blisters **183**, and ten low volume sample blisters **182**. Pouch **210** of FIG. **6** increased the number of low volume sample blisters **282** to 18. However, high density array **581** of pouch **510**, shown in FIG. **12** can have **120** or more second-stage wells **582**. This increase in the number of second-stage reactions enables a wide set of potential diagnostic and human identification applications without the need to increase the size of the pouch and its instrument. Various examples are described herein.

[0171] In one example, it is known that standard commercial immunofluorescence assays for the common respiratory viruses can detect seven viruses: Adenovirus, PIV1, PIV2, PIV3, RSV, Influenza A, and Influenza B. A more complete panel illustratively would include assays for additional five viruses: coronavirus, human metapneumovirus, BOCavirus, Rhinovirus and non-HRV Enterovirus. For highly variable viruses such as Adenovirus or HRV, it is desirable to use multiple primers to target all of the branches of the virus' lineage (illustratively 4 outer and 4 inner primer sets respectively). For other viruses such as coronavirus, there are 4 distinct lineages (229E, NL63, OC43, HKU1) that do not vary from one season to another, but they have diverged sufficiently enough that separate primer sets are required. The illustrative complete respiratory virus panel would also target the SARS coronavirus, possibly the avian influenza HA and N subtypes, and possibly others. Finally, some of the respiratory viruses show such a high rate of sequence variation that it would be beneficial to create more than one nested PCR assay for each such virus, thereby minimizing the chance of false negative results due to sequence variation under the primers. When all of the primer sets described herein are included, such a respiratory virus panel could have 80 or more specific amplicons in the second-stage amplification. The high density array **581** could easily accommodate such a panel in a single pouch **510**.

[0172] A second application of the high density array **581** of pouch **510** would be to determine the identity and the antibiotic resistance spectrum of the multi-drug resistant bac-

teria isolated from infected patients. Current methods require several days to culture the organism and empirically test individual drug resistance profiles. During the time it takes to receive the results, physicians will often administer broad-spectrum antibiotics, which leads to an increase in multi-drug resistant bacteria. PCR primers have been developed to detect the genetic determinants of antibiotic resistance (the antibiotic resistance genes themselves). However because of the large number of variants of some of these genes, a large number of amplicons is required for a complete determination of the resistance profile. Hujer et. al. describe a panel of 62 PCR assays to identify the resistance genes present in Acinetobacter isolates. Again, the high density array **581** could easily accommodate such a panel in a single pouch.

[0173] A third example of the utility of the high density array is in the field of human identification, illustratively for forensic identification of human remains and for paternity testing. Most of the market in human identification is dominated by systems that analyze short tandem repeat sequences (STRs). This analysis has generally required separating the repeats by size, using e.g. capillary electrophoresis. The specialized laboratory equipment used for this purpose has generally not been field portable. There is growing interest in using Single Nucleotide Polymorphisms (SNPs) for identity testing, as there are a large set of techniques for identifying SNPs and some of these are amenable to field use. Sanchez et al. have published a set of **52** well-characterized SNPs that collectively give a very low probability of matching two individuals by chance (a mean match probability of at least 5.0×10^{-19}). In practice, it may take two amplicons for each SNP to accurately type each locus (see, e.g., Zhou et al.). Thus one pouch **510** with 104 second-stage wells **582** could completely type an individual at all of the 52 SNP loci.

[0174] It is understood that there are cost and workflow advantages gained by combining assays from different diagnostic applications into one pouch. For example the complete respiratory virus panel could be combined with the bacterial identification panel. These combinations could simplify manufacturing, since there are fewer types of pouches to assemble. They could also simplify the work of the end user, as there are fewer specific types of pouches that need to be stocked in a clinic, and also reducing the chance of using the wrong pouch for a particular clinical sample. For some applications, these advantages could offset an increase cost of manufacturing the pouch having a greater number of primer pairs. Thus one pouch **510** with 100 or more second-stage wells **582** could be used to accommodate multiple panels of assays.

EXAMPLE 3

Process Controls

[0175] Controls for highly multiplexed assays can be problematic, especially in clinical diagnostic settings where quality must compete with cost per test. The high-density array **582** of pouch **510** potentially increases this problem because of the increased number of diagnostic targets that can be assayed in a single run. Various types of controls are discussed herein.

[0176] Illustrative process controls include mixing an intact organism, for example an organism containing an RNA target, into the patient sample before injecting the sample into the pouch. Such a target could be an intact RNA bacteriophage (MS2 or Q β) or an intact plant RNA virus (Tobacco

Mosaic Virus) or an mRNA present in an intact yeast. Outer primers specific for the RNA target would be present in the first-stage PCR and a well **582** containing the inner primers would be present in the high density array. Detection of amplification product in this well **582** confirms that all of the steps of the process are working correctly. A post-second-stage amplification melt curve could also be used to verify that the correct specific product was made. The crossing point ("Cp") determined from an amplification curve could be used to give a quantitative measure of the integrity of the reagents. For example the Cp can be compared to that of other pouches from the same lot run at a different time. While an intact organism is used, it is understood that purified or isolated nucleic acids may be used if it is not important to test for lysis. In other situations, it may be desirable to use the control to test only the later steps of the analysis. For example, spiking a natural or synthetic nucleic acid template into a well in the high density array along with the cognate primers could be used to test the second-stage PCR reaction, and spiking a nucleic acid template into the first-stage PCR with the appropriate primers in the first-stage PCR amplification mixture and in a well **582** of the second-stage amplification zone will test both the first- and second-stage PCR reactions.

[0177] Process controls such as described above do not test the integrity of the primers specific to the target amplicons. One example of a positive control that tests the integrity of the specific primers uses a mixture of nucleic acids, illustratively synthetic RNAs, as stability and variability often can be better controlled and these sequences cannot be present due to environmental contamination, wherein the mixture contains a nucleic acid for each of the primers present in the particular pouch. In a diagnostic setting, this positive control could be used at the end of a run of pouches used to test patient samples. The mixture is injected into a pouch, illustratively from the same lot as those used for the patient samples, and success is defined by all of the target amplicons providing a positive result. Negative controls can be done in the same way; at the end of a run of pouches used to test patient samples, water or buffer could be injected into a pouch and success defined by all of the target amplicons providing a negative result.

[0178] Individual workflow and protocols in a diagnostic lab may be used to determine the number of patient sample pouches run before the control pouches described above are run. Regardless of how frequently or infrequently the control pouches are run, these controls add to the time and cost of the total system. For this reason, it would be useful to make the controls internal to the pouch. The structure of the high density array **581** allows for the following novel approach to negative controls. In this example, a nucleic acid, illustratively a synthetic amplicon, is spiked into one of the wells **582a** of the high density array **581**. Primers to amplify this sequence are spiked into this well **582a** and into two other wells **582b** and **582c** spaced across the array. Illustratively, the amplicon sequence and primers are artificial and designed so that none of the primers used will amplify another target by chance.

[0179] When a clean, uncontaminated pouch **510** is run in instrument **800**, the well **582a** containing the synthetic target will generate amplicon and therefore be called positive. The two other wells **582a**, **582b** that contain the corresponding primers should not amplify anything in the sample and thus be called negative. Pouch **510** may be treated further, for additional controls. Illustratively, bladder **880/882** holding the

high density array against heater **888** is then depressurized and the contents of the wells **582** are mixed. In one illustrative method, the contents of the wells **582** are mixed as follows: heater **888** is used to cycle the temperature of the high density array above and below the boiling point of the buffer for a short time (for example three cycles of 85° C. for 10 sec then 105° C. for to 20 sec). Bubbles of steam generated in the wells **582** of high density array **581** should force the contents of wells **582** out into the second-stage amplification zone blister **580**. Optionally, the contents of the second-stage amplification zone **580** may be mixed with the contents of rest of the pouch **510** by using the bladders to move liquid from one end of the pouch **510** to the other. The purpose of these steps is to mix the specific contamination control amplicon, along with any specific target amplicons throughout the pouch.

[0180] If the user accidentally opens a pouch after it has been run in this fashion, then both specific target amplicons and the contamination control amplicon will be released. If trace amounts of these nucleic acids contaminate a later pouch run, the instrument may detect the contamination event, as the wells **582b**, **582c** that contained only the primers specific for the synthetic amplicon will score positive. Software in the instrument will alert the user and the results of the run will be flagged as suspect.

[0181] In another method to control contamination, at the end of a run, a DNA degrading chemical or enzyme may be added to destroy substantially all of the DNA products of the first- and second-stage PCR reactions. Illustratively, this can be done in a way similar to the contamination detection method described above, by heating the contents of the second-stage array to above the local boiling temperature, thus drawing the amplified sample out of the wells **582** of the array **851**, mixing the heated liquid with the diluted contents of the 1st stage reaction, adding an aliquot of a DNA degrading substance, illustratively through entry channel **515k**, either with or without cooling the mixture, and allowing the DNA degrading reaction to incubate until substantially all of the DNA produced in the PCR reaction has been destroyed. This can be accomplished using DNAases, acids, or oxidants, as are known in the art.

[0182] It is understood that any of the contamination controls described herein may be used independently or in any combination thereof.

EXAMPLE 4

Array Loading

[0183] FIG. 16 shows another embodiment of a high density array. High density array **681** is similar in configuration to that of high density array **581**. In this illustrative embodiment, high density array **681** is provided with **102** second stage wells **682**, arranged in a circular pattern. As shown, array **681** is also provided with a layer **687** affixed thereto, layer **687** being similar to second layer **587** discussed above, but array **681** has not yet been provided with a pierced layer. While array **681** is the illustrative array for this example, it is understood that array **581** and other arrangements of high density arrays are within the scope of this invention.

[0184] As discussed above, commercial spotters, such as the GeSiM A060-324 Nano-Plotter 2.1/E (Grosserkmannsdorf, Germany), may be used to load high density array **681**. Alternatively, high density array **681** may be spotted using x/y

positionable spotters such as pin-spotters, dot-matrix printers, small-volume automatic pipettes, or micro-fluidic micro-contact spotters.

[0185] FIGS. 17-19 show an illustrative spotter 600. Spotter 600 is provided with a base 601. Attached to base 601 is pump array 620. Adjacent to pump array 620 is loading array 630. Illustrative loading array 630 is configured to receive a 96-well plate, although other plate configurations are within the scope of this disclosure, including 384-well plates, 1536-well plates and plates of other configurations. It is also understood that one or more vials or reservoirs of other configurations may be used for providing the fluid to be spotted. As best seen in FIG. 19, illustrative 96-well plate 636 sits on loading platform 635, the 96-well plate 636 being much taller than standard microtiter plates, to provide larger reservoirs for spotting multiple arrays. However, standard 96-well plates may be used, as shown in FIG. 20. Loading platform 635 may be raised or lowered by action of arm 634.

[0186] In FIG. 19, plate 636 is shown in the lowered position. In this position, the top 633 of plate 636 is not in contact with, nor overlapping with the tips 642 of straws 641, allowing for easy insertion and removal of plate 636. As shown in FIG. 20, loading platform 635 is in the raised position. A plurality of straws 638 extend through support 640 and into each well 637 of plate 636. The straws 638 are tubing that extend from above support 640 to the bottom of each well 637. In the illustrative embodiment, straws 638 are 25 gauge stainless steel. However, any material may be used that is compatible with the fluid to be spotted in array 681. Preferably, the material for straws 638 is rigid or semi-rigid, so as to extend to the bottom of wells 637, so that virtually all fluid in plate 636 may be used. To aid in using as much fluid as possible, the tip 642 of each straw 638 is cut at an angle, to prevent straw 638 from sealing against well 637. Illustratively, tip 642 may be cut at a 30-60°, more illustratively at a 45° angle, but it is understood that the choice of angle may depend on the shape of well 637. For example, if well 637 has a flat bottom, an angle significantly less than 30° may be useful, while a generally conical well 637 may require a greater angle. Alternatively, tip 642 may be notched or grooved, or may be provided with any shape that is not congruent with the bottom of well 637, in configurations where sealing against well 637 may be problematic.

[0187] Each of straws 638 extend upward through its respective orifice 641 in support 640. As shown in the illustrative embodiment, the orifices 641 are configured to align with wells 637, and each orifice is sized to allow free movement of straw 638 within orifice 641. A weight 639 is affixed to the top of each respective straw 638. Each weight 639 biases tip 642 against the bottom of well 637. Cylindrical brass weights are used in the embodiment shown. However, it is understood that this is illustrative only, and that other shapes and materials may be used. It is desired that the weights 639 be sized larger than the orifices 641, so that when plate 636 is removed, weights 639 rest on support 640 and retain each respective straw 638 in position to enter its respective well when the next plate is raised into position.

[0188] In the illustrative embodiment, each straw 638 extends through its respective weight 639 and is connected to a flexible tube 644. However, it is understood that straw 638 and tube 644 may be connected just below or within weight 639, or straw 638 may change composition from a more rigid material to a more flexible material. Illustratively, tube 644 is an elastomeric material, for example silicone or polyure-

thane, with an inner diameter of 0.012 inches and an outer diameter of 0.025 inches. However, it is understood that a variety of materials in other sizes may be used, depending on the specific application. Illustratively, flexible tube 644 is an elastomeric material, but other materials that are sufficiently flexible without cracking or breaking are within the scope of this disclosure.

[0189] As best seen in FIG. 17, the plurality of tubes 644 extend through pump array 620 in a parallel arrangement, and extend to print head 660. FIG. 21 shows cross-sectional view of pump array 620, wherein first pneumatic seal 623 is located closer to loading array 630, and second pneumatic seal 624 is located closer to print head 660. Tube 644 is sandwiched between top support 621 and bottom support 622. Bottom support is provided with three pneumatic elements. First pneumatic seal 623 and second pneumatic seal 624 operate as pinch valves on tube 644, to open and close tube 644 as needed, to allow fluid to flow through tube 644 from wells 637 to print head 660. Peristaltic pump 626 is provided with a pump head 625 that is somewhat offset from the mechanical center, as indicated by dashed line 631, thereby forcing fluid in the direction of print head, particularly when seal 623 is closed and seal 624 is open. Optionally, pump 626 may be provided on an angle (not shown), such that pump head 625 first makes contact with tube 644 closer to seal 623, thereby forcing fluid toward seal 624. Openings 627, 628, and 629 connect to tubing 612, 613, 614, best seen in FIG. 17, which are then connected to a compressed gas source 616. Compressed gas source 616 may be a compressor, or, alternatively, compressed gas source 616 may be a compressed gas cylinder. Springs (not shown) may be used to bias the seals and pump head in the opposite direction from the direction moved by the compressed gas source, thereby allowing the tubing to recover its original shape with less resistance. Approximately 50 psi or less is required to modulate the appropriate amount of fluid in the illustrative embodiment. In the illustrative embodiment, fluid in all tubes 644 are pumped simultaneously by a single peristaltic pump 626, thereby moving generally uniform amounts of fluid through each tube 644. In the illustrative embodiment, tubes 644 are aligned in a parallel arrangement, and seals 623 and 624 and pump 626 are provided linearly. However, other arrangements are within the scope of this disclosure.

[0190] It is understood that the amount of fluid moving through tube 644 to print head 660 will be determined by the diameter of tube 644, the width of pump head 625, and the amount of pressure exerted on tube 644 by pump 626. Adjusting these parameters is within the scope of this disclosure. Also, it is within the scope of this disclosure to pump fluids through tube 644 by other means, as are known in the art, for example, rollers, hydraulic pumps, electromechanical pumps, and other metering devices.

[0191] Print head 660 is provided with 102 positions 662 that align with the 102 wells 682 in high density array 681. Each tube 644 connects to one of the positions 662. 96-well plate 636 is a rectangular array of 96 wells 637, while high density array 681 is a generally circular array of 102 wells 682. By using flexible tubing for tubes 644, one can arrange for transfer of fluid from any of the wells 637 in plate 636 to any of the wells 682 in high density array 681, merely by affixing a specific tube 644 to a specific location in print head 660. As shown in FIGS. 17-18, there are 96 tubes 644, leaving six positions 662 on print head 660 empty. When the fluid is transferred to array 681, six wells 682 will remain empty, as

seen as the six unfilled wells 682 in FIG. 18. However, it is understood that several straws 638 may be attached to a single weight 639, such that one well 637 in plate 636 is feeding more than one location on print head 660. If reactions are to be run in duplicate or triplicate in array 681, it may be desirable to place two or three straws 638 in each well 637 of plate 636, but use fewer wells 637 in plate 636. It is understood that a plate with 102 wells may be used to transfer fluid through straws 638. Reconfiguration is within the scope of this disclosure, and reconfiguration may be desirable, if spotter 600 is used for multiple different arrays 681. Also, it is understood that the configuration of print head 660 and corresponding array 681 is illustrative only, and other configurations of the print head and array are within the scope of this disclosure, provided that the print head generally aligns with a portion or all of the array. For example, a print head aligning with array 581, as shown in FIG. 15, would be within the scope of this disclosure. Also, for very high density arrays with very small wells, it may not be practical to form drops small enough not to touch while on the print head. In such cases, it may be desirable to use two or more print heads, and use each to load a respective portion of the array.

[0192] As best seen in FIG. 19, each tube 644 extends through print head 660, such that each tube terminates in an orifice 645 just below print head 660. In the illustrative embodiment, a small piece of metal tubing is provided at the end of each tube 644, which may or may not extend through print head 660, to provide this orifice 645, illustratively the same metal tubing as is used for straws 638. Illustratively, an end 643 of orifice 645 is polished to a flat, smooth surface, thus reflecting light and aiding in visualization of drops 692, as discussed below. In the illustrative embodiment, a 250 micron orifice is used, which is sized to provide enough surface tension to form and support a drop of fluid of 0.1 to 10.0 μl , and more illustratively of 0.5 to 1.0 μl . However, this is exemplary only and other sizes of orifice and drop are within the scope of this disclosure. In an alternate embodiment shown in FIG. 27, each tube 644a may terminate at or within print head 660a and print head 660a may be provided with protrusions 677a that are illustratively formed integrally with the print head body. Protrusions 677a may be painted black or other color or may be provided with a metallic coating, to aid in drop visualization. Orifices 645a may be made from or coated with a material conducive for transferring fluids. For example, if the fluid is aqueous, a print head made of hydrophobic materials may be used. In one illustrative embodiment, the print head 660a may be made from Teflon® or may be made from another material, such as stainless steel, with a Teflon® coating. Such materials may be used in an embodiment wherein the orifices are provided on the print head itself (FIG. 27) or in an embodiment wherein each tube 644 extends through print head 660 (FIG. 19), to reduce transfer of the fluids to print head 660. Further, as shown in FIG. 25, a deionizer 680 may be provided to reduce static effects and aid in transfer of the drops from print head 660.

[0193] Upon operation of pump 626, fluid is moved from wells 637 of plate 636, such that drops 692 are formed at each orifice that is connected via tube 644 to its well 637. As best seen in FIG. 17, an imaging system, illustratively comprising a light source and camera, is provided. The light source 672, illustratively high incident lights although other configurations are possible, are provided to illuminate drops 692. A camera 670, illustratively mounted just below opening 668 in

base 601, images drops 692. FIG. 22 is a screen shot provided on display 695 (as shown in FIG. 26) of a bottom surface 661 of print head 660, showing drops 692 attached to each of the 96 orifices that are attached to tubes 644. Because there are 102 positions 662 on print head 660, and the illustrative example only uses one straw 638 per well 637, six of the positions 662 are without drops 692, showing six tube orifices 645. The remaining 96 orifices are obscured by their respective drops 692. FIG. 23 is similar to FIG. 22, except that twenty drops are missing, as indicated by empty positions 691, revealing an extra twenty tube orifices.

[0194] Camera 670 is connected to a processor 694 (see FIG. 26) that is programmed to determine whether all drops 692 are sufficient, illustratively by approximating volume ($4/3 \pi r^3$) and comparing to an acceptable volume range. The programming may also include detection of bubbles, which may render a drop insufficient. In one illustrative embodiment, the processor may be programmed with the following steps:

[0195] (1) Signals the camera 670 to acquire an image of the print head prior to drop formation,

[0196] (2) Qualifies the image to ensure that no drops are present on the print head 660,

[0197] (3) If droplets are present, then the software notifies the user, otherwise it signals the spotter to create drops 692,

[0198] (4) Signals the camera 670 to acquire a second image of the print head with drops 692,

[0199] (5) Qualifies the image to ensure proper location and size of the drops 692,

[0200] (6) If drops 692 fail the qualification in Step (5), then the software notifies the user, otherwise it signals the spotter 600 to print the array 681,

[0201] (7) After the array 681 is printed, the software signals the camera 670 to acquire a third image of the print head 660 without drops,

[0202] (8) Qualifies the image to ensure that no drops are present on the print head 660.

[0203] (9) The software notifies the user of the status of the qualification per Step (8).

[0204] The image analysis used to qualify the drop presence and absence in Steps 2, 5 and 8, rely on standard binary threshold techniques.

[0205] As part of the qualification of the drop formation in Step 5, in one illustrative embodiment, the image is analyzed to determine the location and diameter (in pixels) of each drop. The software qualifies that the locations of the centers of each drop are within a prescribed distance of the centers of the orifices 641. Next, the software determines the radius of each of the drops and qualifies these as being greater than a lower threshold, to ensure that the amount of primer present in each well is sufficient for PCR amplification, and less than an upper threshold, to ensure that the droplet is not deposited outside of the target well 682 on the array 681. The lower and upper thresholds may be 1%, 2%, 5%, 10%, 15%, 20% or any other percentage to provide a range of fluid from the drops that would be tolerable in the application.

[0206] As an alternative qualification of the drop formation in Step 5, the drops may be masked when imaged, each drop with a circular mask. Rather than using the radius as a standard, the mask is used. If the drop completely fills the circle and does not exceed the circle, then the drop passes the qualification. If the drop does not completely fill the circle or exceeds the circle size, then the drop will fail the qualification. The width of the circle line is chosen to provide the

threshold, with a thicker circle line providing a larger range and a thinner circle line providing a smaller range.

[0207] Alternatively, visual inspection of the image may be used to determine whether all drops 692 are sufficient. If all drops 692 are sufficient, they may be transferred to array 681. It may be desirable to include a colored or fluorescent dye in the fluid to aid with visualization. Alternatively or in addition, end 643 of orifice 641 may be polished smooth to reflect light and aid in visualization. If fluorescent dyes are used for PCR detection, it may be desirable to visualize that dye, or to use another dye for visualization that will not interfere with the fluorescence of PCR. For example, LCGreen® Plus could be used for PCR detection, while an IRDye® (Licor, Lincoln, Nebr.) could be used for drop visualization. Other dyes are known in the art. Optionally, print head 660, array 681, or both may be visualized after transfer to determine whether sufficient volume from each drop 692 has been transferred from print head 660.

[0208] If the drops 692 are insufficient by failing to meet the predetermined standard, the drops may be transferred to array 681, as discussed above, but array 681 may be discarded. Alternatively, insufficient drops 692 may be removed from print head 660 by blotting or other means.

[0209] To better see other components, placement arm 652 was omitted from FIG. 17 and the near side of FIG. 19. However, placement arm is best seen in FIGS. 18, 24, and 25. Placement arm 652 is provided with a platform 653 for receiving array 681. Array 681 is provided with one or more, preferably two or more openings 655, through which alignment pins 654 extend. The openings 655 may be configured to snap onto alignment pins 654 for more secure alignment. Alternatively, a recess may be provided to receive array 681. It is understood that other methods for proper placement of array 681 onto platform 653 are within the scope of this disclosure. If the drops are determined to be sufficient by meeting a predetermined standard, placement arm 652 is moved upward, so that each well 682 of array 681 is placed in contact with its respective drop 692. Once contact is made, surface tension between each drop 692 and its respective orifice 645 is released, and the drop 692 is transferred to its respective well 682. Placement arm 652 may then be lowered, array 681 removed, and the process repeated, as long as there is sufficient fluid in each of the wells 637 of plate 636. It is understood that, after drops 692 are transferred, array 681 may be processed as discussed above with respect to array 581, to become the second-stage for any of the pouches described herein.

[0210] FIGS. 24-25 show detail of one illustrative placement arm 652. In this example, placement arm 652 includes a planar 4-bar mechanism 664, wherein coupler link 656 connects platform 653 to rotating arm 659. Coupler link 656 is attached to follower link 658 at attachment point 649, and to rotating arm 659 at attachment point 648. Rotating arm 659 is attached to top structure 605 at attachment point 647, and follower link 658 is attached to top structure 605 at attachment point 650. The short link 669 is determined by the distance between attachment points 647 and 648. Top structure 605 serves as the ground link of the 4-bar mechanism. In the illustrative embodiment, the lengths of links are chosen such that high density array 681 follows a coupler curve that moves vertically immediately prior to contacting print head 660. This vertical movement is desirable so that each drop 692 makes contact with its respective well 682, while minimizing cross-contamination that may occur if the movement

immediately prior to contact is not vertical. This coupler curve movement is also useful because the opening 668 for camera 670 may be placed directly below print head 660. Platen 663 is joined to coupler link 656 at rotating joint 646. Rotating joint 646 may be adjusted to provide planar alignment between array 681 and print head 660. After alignment is set, rotating joint 646 may be locked down to provide continued alignment. As shown in FIG. 19, two identical planar 4-bar mechanisms 664 are provided, one on either side of top structure 605 and are locked in synchrony that rotates the two driver links 657 together to provide proper alignment of array 681 at print head 660, as shown in FIG. 25. It is understood that planar 4-bar mechanism 664 is illustrative only, and that other methods of placing an array to print head 660 are within the scope of this disclosure, including other manual and automatic means.

[0211] Print head 660 is affixed to pump plate 667, which is affixed to pump array 620. Pump plate 667 may be movable relative to pump array 620, allowing for alignment with camera 670. Alternatively, pump plate 667 may be provided with multiple attachment locations on pump array 620, allowing for lateral positioning. Such lateral positioning optionally allows multiple arrays 681, which may be seated adjacent to one another on platen 663, to be filled by a single pump head 660, or allows pump head 660 to print a larger array by first printing in one position and then printing in a second position.

[0212] FIGS. 24-25 show an illustrative arrangement for camera 670. In this illustrative embodiment, camera 670 is mounted horizontally, and a mirror 674 is used to reflect the image received through opening 668. However, it is understood that other arrangements are within the scope of this invention, including but not limited to omission of the mirror and vertical mounting of camera 670 below opening 668. A bottom casing 604 is provided to protect camera 670. A top casing (not shown) may be provided to protect many components that are above base 601. However, it is preferable that such top casing allows relatively easy insertion and removal of array 681 and plate 636.

[0213] Returning to FIGS. 22-23 are a plurality of standoffs 675 that are build into print head 660, illustratively six standoffs 675, although other numbers of standoffs may be used. It has been found that when layer 687 is affixed to array 681, array 681 often bows somewhat. The standoffs 675 function to push array 681 flat against platen 663 during transfer of drops 692 to wells 682.

[0214] FIG. 26 is a block diagram of a system 698 for spotting arrays. The system 698 includes a computing device 696, which may comprise one or more processors 694, memories (not shown), computer-readable media (not shown), one or more HMI devices (e.g., input-output devices (not shown), displays 695, printers (not shown), and the like), one or more communications interfaces (not shown), and the like. The computing device 696 may be communicatively coupled to a spotter 600, which may be coupled to a compressed gas source 616. The computing device may control one or more components of the system, including the pump array 620, the placement arm 652, the loading platform 635, the imaging system 676, or any combination. It is understood that the system may be configured such that various of the components may be operated manually.

[0215] Spotter 600 may be cleaned by insertion of a plate 636 in which all wells 637 contain cleaning solution, and the pump 626 activated until all cleaning solution has exited the

orifices 641. A receptacle may be placed under print head 660 to collect the cleaning solution.

REFERENCES

- [0216] 1. Wittwer C T, Fillmore G C, Garling D J. Minimizing the time required for DNA amplification by efficient heat transfer to small samples. *Anal Biochem*. 1990 May 1;186(2):328-31.
- [0217] 2. Wittwer C T, Garling D J. Rapid cycle DNA amplification: time and temperature optimization. *Biotechniques*. 1991 Jan;10(1):76-83.
- [0218] 3. Wittwer C T, Herrmann M G, Moss A A, Rasmussen R P. Continuous fluorescence monitoring of rapid cycle DNA amplification. *Biotechniques*. 1997 Jan;22(1):130-1, 134-8.
- [0219] 4. Wittwer C T, Ririe K M, Andrew R V, David D A, Gundry R A, Balis U J. The LightCycler: a microvolume multisample fluorimeter with rapid temperature control. *Biotechniques*. 1997 Jan;22(1):176-81
- [0220] 5. Gundry C N, Vandersteen J G, Reed G H, Pryor R J, Chen J, Wittwer C T. Amplicon melting analysis with labeled primers: a closed-tube method for differentiating homozygotes and heterozygotes. *Clin Chem*. 2003 Mar;49(3):396-406.
- [0221] 6. Wittwer C T, Reed G H, Gundry C N, Vandersteen J G, Pryor R J., High-resolution genotyping by amplicon melting analysis using LCGreen. *Clin Chem*. 2003 Jun;49(6 Pt 1):853-60.
- [0222] 7. McKinney J T, Longo N, Hahn S, Matern D, Rinaldo P, Dobrowolski S F. Comprehensive analysis of the human medium chain acyl-CoA dehydrogenase gene. *Mol Gen Metab*. In press
- [0223] 8. Dobrowolski S F, Amat di San Filippo C, McKinney J T, Wilcken B, Longo N Identification of novel mutations in the SLC22A5 gene in primary carnitine deficiency with dye-binding/high-resolution thermal denaturation, *Human Mutation*, submitted
- [0224] 9. McKinney J T, Saunders C, Dobrowolski S F, High-resolution melting analysis of the human galactose-1-phosphate uridyl transferase gene, in preparation
- [0225] 10. <http://www.defenselink.mil/contracts/2003/ct20030925.html>
- [0226] 11. Poritz M A, Abbott R, Gerber T, Thatcher S, Bird A, Tuck A, Newswander A M, Belisle S, Ririe K, A Handheld, Battery-operated Real-time PCR Machine, American Society for Microbiology Annual Meeting, Baltimore Md., March 9-12, 2003
- [0227] 12. Elnifro E M, Ashshi A M, Cooper R J, Klapper P E. Multiplex PCR: optimization and application in diagnostic virology. *Clin Microbiol Rev*. 2000 Oct;13(4):559-70. Review.
- [0228] 13. Elnifro E M, Cooper R J, Klapper P E, Yeo A C, Tullo A B. Multiplex polymerase chain reaction for diagnosis of viral and chlamydial keratoconjunctivitis. *Invest Ophthalmol Vis Sci*. 2000 Jun;41(7):1818-22.
- [0229] 14. Giaever, G., et al. Genomic profiling of drug sensitivities via induced haploinsufficiency. *Nature Genetics*. 1999, 21, 278-283
- [0230] 15. Winzeler, E., et al Functional Characterization of the *Saccharomyces cerevisiae* Genome by Gene Deletion and Parallel Analysis. *Science*. 1999. 285, 901-906.
- [0231] 16. Sano, T., C. L. Smith, and C. R. Cantor, Immuno-PCR: very sensitive antigen detection by means of specific antibody-DNA conjugates. *Science*, 1992. 258(5079): p. 120-2.
- [0232] 17. Niemeyer, C. M., M. Adler, and R. Wacker, Immuno-PCR: high sensitivity detection of proteins by nucleic acid amplification. *Trends Biotechnol*, 2005. 23(4): p. 208-16.
- [0233] 18. Adler, M., Immuno-PCR as a clinical laboratory tool. *Adv Clin Chem*, 2005. 39: p. 239-92.
- [0234] 19. Barletta, J. M., et al., Detection of ultra-low levels of pathologic prion protein in scrapie infected hamster brain homogenates using real-time immuno-PCR. *J Virol Methods*, 2005. 127(2): p. 154-64.
- [0235] 20. Adler, M., et al., Detection of Rotavirus from stool samples using a standardized immuno-PCR ("Imperacer") method with end-point and real-time detection. *Biochem Biophys Res Commun*, 2005. 333(4): p. 1289-94.
- [0236] 21. Lind, K. and M. Kubista, Development and evaluation of three real-time immuno-PCR assemblages for quantification of PSA. *J Immunol Methods*, 2005. 304(1-2): p. 107-16.
- [0237] 22. Schiavo, S., et al., Comparison of fluorometric detection methods for quantitative polymerase chain reaction (PCR). *J Immunoassay Immunochem*, 2005. 26(1): p. 1-12.
- [0238] 23. Barletta, J. M., D. C. Edelman, and N. T. Constantine, Lowering the detection limits of HIV-1 viral load using real-time immuno-PCR for HIV-1 p24 antigen. *Am J Clin Pathol*, 2004. 122(1): p. 20-7.
- [0239] 24. McKie, A., et al., A quantitative immuno-PCR assay for the detection of mumps-specific IgG. *J Immunol Methods*, 2002. 270(1): p. 135-41.
- [0240] 25. Chao, H. Y., et al., A highly sensitive immuno-polymerase chain reaction assay for Clostridium botulinum neurotoxin type A. *Toxicon*, 2004. 43(1): p. 27-34.
- [0241] 26. Wu, H. C., et al., Detection of Clostridium botulinum neurotoxin type A using immuno-PCR. *Lett Appl Microbiol*, 2001. 32(5): p. 321-5.
- [0242] 27. Liang, H., et al., A highly sensitive immuno-PCR assay for detecting Group A Streptococcus. *J Immunol Methods*, 2003. 279(1-2): p. 101-10.
- [0243] 28. Adler, M., R. Wacker, and C. M. Niemeyer, A real-time immuno-PCR assay for routine ultrasensitive quantification of proteins. *Biochem Biophys Res Commun*, 2003. 308(2): p. 240-50.
- [0244] 29. Allen, R. C., et al., An immuno-PCR method for detecting Bacillus thuringiensis CryIAc toxin. *J Immunol Methods*, 2006. 308(1-2): p. 109-15.
- [0245] 30. Hendrickson, E. R., et al., High sensitivity multianalyte immunoassay using covalent DNA-labeled antibodies and polymerase chain reaction. *Nucleic Acids Res*, 1995. 23(3): p. 522-9.
- [0246] 31. Joerger, R. D., et al., Analyte detection with DNA-labeled antibodies and polymerase chain reaction. *Clin Chem*, 1995. 41(9): p. 1371-7.
- [0247] 32. Hujer, et. al., Multi-drug Resistant Acinetobacter spp. Isolates from Military and Civilian Patients Treated at the Walter Reed Army Medical Center: Analysis of Antibiotic Resistance Genes. *Antimicrob Agents Chemother*. 2006 Sep 25.
- [0248] 33. Sanchez et al., A multiplex assay with 52 single nucleotide polymorphisms for human identification. *Electrophoresis*. 2006 v27 p.1713-24.

[0249] 34. Zhou et al., Closed-tube genotyping with unlabeled oligonucleotide probes and a saturating DNA dye. *Clin Chem.* 2004 50 p.1328-35.

[0250] Although the invention has been described in detail with reference to preferred embodiments, variations and modifications exist within the scope and spirit of the invention as described and defined in the following claims.

1. A spotter device for spotting a plurality of fluids into an array comprising:

- a plurality of reservoirs provided in a first configuration, each reservoir holding its respective fluid,
- a print head having a plurality of positions provided in a second configuration, the second configuration being different from the first configuration,
- a plurality of tubes, each tube configured to provide fluid communication from a reservoir at a first end of the tube to a position in the print head at the second end of the tube, and
- a pump for pumping fluid through the tubes from the reservoir to the print head.

2. The spotter device of claim 1, further comprising

- a support provided above the reservoirs,
- a plurality of straws, each straw connected to a first end of its respective tube, each straw extending from the first end of its respective tube and through the support and into a reservoir, each straw having a weight positioned above the support to bias the straw to a bottom of the straw's respective reservoir.

3. The spotter device of claim 2, wherein upon removal of the reservoirs, the weights rest on the support.

4. The spotter device of claim 2, wherein the straws are rigid or semi-rigid, and the tubes are elastomeric.

5. The spotter device of claim 1, wherein the pump further comprises:

- a pump configured for simultaneous pumping of all tubes.

6. The spotter device of claim 5, wherein the pump is a peristaltic pump provided with an offset pump head.

7. The spotter device of claim 5, wherein the second end of each tube comprises an orifice, and activation of the pump moves fluid from the reservoirs resulting in a drop of fluid at each orifice.

8. The spotter device of claim 7, wherein the array is provided with a plurality of wells provided in the second configuration.

9. The spotter device of claim 8, further comprising a placement arm for receiving the array and moving the array to the print head, such that each drop is transferred to its respective array well.

10. The spotter device of claim 7, further comprising a camera positioned in visual contact with the print head, the camera further operable to provide an image of the drops.

11. The spotter device of claim 10, further comprising a CPU, the CPU having software configured to analyze the image, the software operable to determine whether each drop meets a predetermined standard.

12. The spotter device of claim 10, further comprising a light source to illuminate the drops.

13. The spotter device of claim 12, wherein the light source is a high-incident light source.

14. The spotter device of claim 12, wherein each orifice has an end polished to a flat, smooth surface, the end configured for reflecting light from the light source back into its respective drop.

15. The spotter device of claim 10, wherein the fluid in each of the reservoirs contains a fluorescent dye to aid in imaging the drops.

16. The spotter device of claim 1, wherein the tubes are removably connected to the print head so that any preselected reservoir in fluid communication with a tube may be set to provide fluid from the preselected reservoir to any position on the print head.

17. The spotter device of claim 1, wherein the plurality of reservoirs are wells in a 96-well plate.

18. A method for printing an array having a plurality of wells in a configuration, comprising

- simultaneously pumping fluid from a plurality of reservoirs to a plurality of positions on a print head to form a plurality of drops on the print head having the same configuration as the array,

moving the array into contact with the drops, and simultaneously transferring each respective drop into its respective well.

19. The method of claim 18, further comprising imaging the drops and determining whether all of the plurality of drops are sufficient prior to moving the array into contact with the drops.

20. The method of claim 19, wherein if one or more drops are determined not to be sufficient, the array is discarded.

21. The method of claim 19, wherein if one or more of the drops are determined not to be sufficient, a blotting material is moved into contact with the drops, and the pumping and imaging steps are repeated.

22. An array produced by the method of claim 18.

23. A system for delivering one or more liquids into a preselected array of a plurality of wells comprising:

- a plurality of tubes, each tube having a first end in fluid communication with a reservoir, and a second end terminating in an orifice;

a plurality of the reservoirs, the reservoirs provided in a predetermined configuration relative to one another;

a print head operable to movably hold each orifice in a predetermined position such that the position of each orifice corresponds to a well in the preselected array of wells;

a plurality of straws, each straw having a hollow opening connecting a first end to a second end, the first end fluidly connected to the first end of a corresponding tube and the second end removably in contact with a bottom portion of a corresponding reservoir;

and a metering device operable to urge a preselected amount of fluid from the second end of each straw through its corresponding tube, and out its corresponding orifice.

24. The system of claim 23, wherein the metering device is located between the first end and the second end of the plurality of tubes.

25. The system of claim 23, further comprising an array of a plurality of wells, each well operable to receive the preselected amount of liquid from a corresponding orifice.

26. The system of claim 23, wherein the number of wells exceeds the number of reservoirs.

27. The system of claim 26, wherein each reservoir comprises a bottom portion operable to hold a preselected amount of liquid, and further comprising a top portion operable to receive one or more straws.

28. The system of claim **27**, further comprising one or more valves in fluid communication with each tube, said one or more valve operable to stop fluid travel through each tube.

29. The system of claim **23**, wherein each orifice comprises an inner lumen and an outer surface, and wherein the orifice is sized and shaped to retain a droplet of a preselected volume of the liquid adjacent to its outer surface until surface tension is released.

30. The system of claim **29**, wherein preselected array of a plurality of wells is removably held upon a movable platform, the movable platform having a first position and a second position relative to the print head;

the first position being within close proximity of the print head such that each of the plurality of wells is in contact with the droplet retained by the corresponding orifice; and

the second position being distal from the print head such that no contact is made between any well and any droplet retained by the corresponding orifice.

31. The system of claim **30**, wherein the first position does not bring any well in contact with any orifice.

32. The system of claim **23**, wherein the metering device is a peristaltic pump.

33. The system of claim **23**, wherein that the position of two or more orifices correspond to a single well in the preselected array of wells.

34. The system of claim **23**, further comprising an imaging system, and a computing device,

wherein the computing device interfaces with the imaging system to accept or reject an array of drops at the print head, either prior to or subsequent to transfer to the array of wells.

35. The system of claim **34**, wherein the imaging system determines a size for each drop and each drop is accepted or rejected by comparing the size to a standard.

36. The system of claim **35**, wherein the size is a radius.

37. The system of claim **23**, further comprising a deionizer configured to aid in transfer of the fluid from print head to the array of wells.

* * * * *