

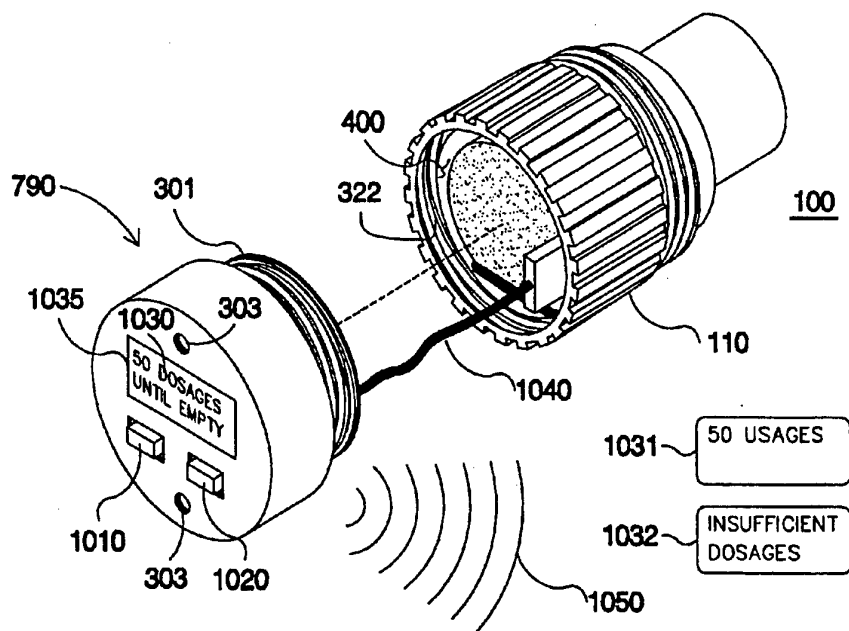

INTERNATIONAL APPLICATION PUBLISHED UNDER THE PATENT COOPERATION TREATY (PCT)

<p>(51) International Patent Classification ⁵ : A61M 15/00, 16/00, B05D 7/14, B65D 83/06</p>	A1	<p>(11) International Publication Number: WO 95/07724 (43) International Publication Date: 23 March 1995 (23.03.95)</p>
<p>(21) International Application Number: PCT/US94/10424 (22) International Filing Date: 14 September 1994 (14.09.94) (30) Priority Data: 08/122,126 16 September 1993 (16.09.93) US (71) Applicant: MEDTRAC TECHNOLOGIES INC. [US/US]; Suite 115, 12364 Alameda Parkway, Lakewood, CO 80228 (US). (72) Inventors: WOLF, James, L.; 12 Sand Cherry Street, Littleton, CO 80121 (US). SALLIS, Daniel, V.; 5720 Blue Sage Drive, Littleton, CO 80123 (US). (74) Agent: CRABTREE, Edwin, H.; Suite 575, 3773 Cherry Creek N. Drive, Denver, CO 80209 (US).</p>		<p>(81) Designated States: European patent (AT, BE, CH, DE, DK, ES, FR, GB, GR, IE, IT, LU, MC, NL, PT, SE). Published <i>With international search report.</i></p>

(54) Title: DRY POWDER INHALER HAVING ELECTRONIC SENSING AND SIGNALLING



(57) Abstract

A dry powder inhaler (100) having a monitor for prescribed dosages of medicament received through the mouthpiece, an electronic housing (110) for computing and recording when a proper amount of medicament is released, when a proper amount of airflow is inhaled, and when the dispenser or inhaler is removed and replaced (350, 351) on the electronic housing. One embodiment of the invention includes an activation sheath (120) received around and secured to the dispenser. The electronic housing includes a first and second proximity reed switch (435, 436) for recording when a proper dose of medicament is released, and a fast response flow thermistor (425) for measuring when sufficient airflow is being inhaled.

FOR THE PURPOSES OF INFORMATION ONLY

Codes used to identify States party to the PCT on the front pages of pamphlets publishing international applications under the PCT.

AT	Austria	GB	United Kingdom	MR	Mauritania
AU	Australia	GE	Georgia	MW	Malawi
BB	Barbados	GN	Guinea	NE	Niger
BE	Belgium	GR	Greece	NL	Netherlands
BF	Burkina Faso	HU	Hungary	NO	Norway
BG	Bulgaria	IE	Ireland	NZ	New Zealand
BJ	Benin	IT	Italy	PL	Poland
BR	Brazil	JP	Japan	PT	Portugal
BY	Belarus	KE	Kenya	RO	Romania
CA	Canada	KG	Kyrgystan	RU	Russian Federation
CF	Central African Republic	KP	Democratic People's Republic of Korea	SD	Sudan
CG	Congo	KR	Republic of Korea	SE	Sweden
CH	Switzerland	KZ	Kazakhstan	SI	Slovenia
CI	Côte d'Ivoire	LI	Liechtenstein	SK	Slovakia
CM	Cameroon	LK	Sri Lanka	SN	Senegal
CN	China	LU	Luxembourg	TD	Chad
CS	Czechoslovakia	LV	Latvia	TG	Togo
CZ	Czech Republic	MC	Monaco	TJ	Tajikistan
DE	Germany	MD	Republic of Moldova	TT	Trinidad and Tobago
DK	Denmark	MG	Madagascar	UA	Ukraine
ES	Spain	ML	Mali	US	United States of America
FI	Finland	MN	Mongolia	UZ	Uzbekistan
FR	France			VN	Viet Nam
GA	Gabon				

DRY POWDER INHALER HAVING ELECTRONIC SENSING AND SIGNALLING

TECHNICAL FIELD

The present invention relates to the field of medication monitoring and, more particularly, to a device which attaches to conventional medication delivery systems, such as dry power medication dispensing package, for positive recording of prescribed dosages and system to analyze chronologic report.

BACKGROUND OF THE INVENTION

In the prior issued patent entitled "Timed Pill Monitor and Dispenser", U.S. Patent No. 4,662,537, issued on May 5, 1987 to the present inventor, a medication monitor was disclosed wherein pre-packaged medication "pills" were placed into compartmental chambers on a hand held device for later usage. Such a system is useful for recording the event of each time a chamber was accessed and a pile removed for prescribed medication. The present invention provides a positive indication that dry power medication has been properly dispensed, inhaled and logged.

Prior to the filing of this application, the inventor conducted a patentability investigation for a system that monitors the administration of proscribed dry power drugs, and provide a chronological report for all activity therewith. The following patents in addition to the above stated patent were uncovered in he search:

Inventor	Reg. No.	Date
Kehr et al.	5,200,891	Apr. 6, 1993
Johnson, IV et al.	5,133,343	Jul. 28, 1992
Wood et al.	5,097,429	Mar. 17, 1992
Moulding	5,042,685	Aug. 27, 1991
Foley	5,042,467	Aug. 27, 1991
Moulding	4,869,352	Sep. 26, 1989
Behl	4,473,884	Sep. 25, 1984
Moulding	4,460,106	Jul. 17, 1984

Discussion of discovered prior art:

5 The patent issued to Kehr et al (U.S. Letters Patent No. 5,200,891) pertains to a device having a plurality of compartments, each of which store medication pills and an electrical signaling system to emit medication alert signals. The disclosed signals indicate that medication should be taken, from which compartment and the quantity. The device of Kehr has a high degree of inter-action between the user and its operation by selecting push-buttons and reading messages on the device display.

10 In the apparatus of Johnson, IV et al. (U.S. Letters Patent No. 5,133,343) has a user's mouthpiece housed therein an automatically actuated commercially available and replaceable inhalers for discharging a medicated vapor. The primary objective of Johnson, IV invention is to provide a device for actuating an inhaler in response to inhalation by a user.

15 In the 1992 patent issued to Wood et al. (U.S. Letters Patent No. 5,097,429) pertains to a user programmable microprocessor based apparatus which acts as a reminder to a medication schedule of events. When user programs parameters relating to intervals of medication, the device prompts the user by signaling alarm.

20 The third patent of Moulding (U.S. Letters Patent No.) 5,042,685, Aug. 27, 1991) manages the dispensing of pills. While the second patent of Moulding (U.S. Letters Patent No. 4,869,352, Sep. 26, 1989) pertains to conforming to the shape and size of pill for dispensing, and Moulding's July 17, 1984 patent (U.S. Letter Patent No. 4,460,106) concerns the counting of pills being dispensed.

25 In the Foley patent (U.S. Letters Patent No. 5,042,467) teaches improved misting of inhaler medication which provides warning by means of sonic signalling if the user inhales too vigorously.

30 In the 1984 patent issued to Behl (U.S. Letters Patent No. 4,473,884) sets forth an electronically controlled medication dispenser with a second pharmacy

5 programmer used to program the dispenser. The dispenser includes a plurality of compartments for storage of tablets or pills. Each compartment has associated indicators which activate and are announced audibly, first softly, and then increasingly in magnitude to a programmed time schedule. The user would then open indicated compartment and take the suggested dosage of medication. The pharmacy desktop sized programmer may program the electronic dispenser to optimize the medication schedule with user's personal eating and sleeping habits. Such information is programmed into a non-volatile memory within.

10 None of the above approaches disclosed an approach for chronologically recording the administration of dry powder medication as a matter of positive fact as to the dispensing and inhalation. And, preserving recorded data for later retrieval and analysis of user's historical medication dispensing activity so doctors may better make prognosis based on drug proscribing.

20 DISCLOSURE OF THE INVENTION

An object of the present invention is to provide a portable, highly miniaturized device which when attached to a conventional medication dry powder dispenser will positively monitor the administration of the medication.

25 Another object of the invention is the device includes a sensor placed in an air flow path for measuring when sufficient air flow is being drawn into the dispenser, mixed with the dry powder and out a mouthpiece of the dispenser. Still another object of the dry powder inhalant device is an electronic package in a housing of the invention makes a record of when a proper dosage of dry powder is released in the dispenser, when sufficient air flow is received in the dispenser when the dry powder is released and when the dispenser is removed and replaced on the electronic package.

30 Yet another object of the invention is the electronic package of the dry powder inhalant device can be

periodically connected to a system by a Doctor's office, hospital, and like medical facilities to up-load stored information and analyze the chronologic report stored within. This may be accomplish directly or through a telephone and a modem.

The dry powder medication inhalant device is adapted for mounting on a conventional medication dry powder dispenser having a mouthpiece incorporated in one end of the dispenser. The device is designed for monitoring prescribed dosages of dry powder medication received through the mouthpiece, the lips and into the mouth, throat, and respiratory system of a user of the device. The invention includes an electronic housing mounted on the dispenser for computing and recording when a proper amount of dry powder is released inside the dispenser, when a proper amount of air flow is inhaled through the dispenser for mixing with the dry powder, and when each dispenser or dry powder container is removed and replaced on the electronic housing. The device, in one embodiment, includes an activation sheath received around and secured to a portion of the dispenser. A lower end of the sheath abuts the electronic housing with the mouthpiece extending upwardly and through an upper end of the sheath. The electronic housing includes a first and second proximity reed switch for recording when a proper dosage of dry powder is released inside the dispenser by properly rotating the sheath and dispenser a fixed distance in one direction on the electronic housing and rotating the sheath and dispenser a fixed distance in an opposite direction. The electronic housing also includes a fast response thermistor for measuring when sufficient air flow is being drawn into the housing, into the dispenser and mixed with the dry powder and out the mouthpiece when using the device.

These and other objects of the present invention will become apparent to those skilled in the art from the following detailed description, showing the contemplated novel construction, combination, and elements as herein

described, and more particularly defined by the appended claims, it being understood that changes in the precise embodiments to the herein disclosed invention are meant to be included as coming within the scope of the claims, except insofar as they may be precluded by the prior art.

BRIEF DESCRIPTION OF THE DRAWINGS

The accompanying drawings illustrate complete preferred embodiments of the present invention according to the best modes presently devised for the practical application of the principles thereof, and in which:

FIGURE 1 sets forth a perspective view of present invention showing sanitation cover and activation sheath removed.

FIGURE 2a is a side planar view of a conventional medication dry powder inhalant package.

FIGURE 2b is an end planar view of Figure 2a.

FIGURE 2c is a side planar view of Figure 2a with cover and end cap removed showing main body of conventional dry powder medication inhalant package.

FIGURE 2d is a side planar view of the device of the present invention with sanitation cover and activation sheath detached from electronics housing end cap, and showing path where conventional dry powder medication inhalant package would be placed.

FIGURE 2e is a side planar view of the device of the present invention fully assembled with conventional dry powder medication inhalant package within.

FIGURE 2f is an end planar view of Figure 2e.

FIGURE 3a-3f are cross-sectional views showing the inner chambers and air passages of the present invention.

FIGURE 4a is a side planar view of the electronics assembly and sensing elements of the present invention.

FIGURE 4b is a top planar view of the electronics assembly and sensing elements of the present invention.

FIGURE 4c is a bottom planar view of the electronics assembly of the present invention.

FIGURE 4d is a partial perspective view of Figure 4b

showing detail of electronic main sensing element.

FIGURE 5 is a side planar illustration showing the device of Figure 2e as it would be used by a patient and showing the interrelationships of air passage chambers.

5 FIGURE 6 sets forth a perspective illustration of an alternate embodiment showing a different manufacturer of conventional dry powder medication inhalant package.

FIGURE 7 is a schematic block diagram of the electronics of the present invention.

10 FIGURE 8 sets forth a state table for the control circuit of Figure 7.

FIGURE 9 sets forth an illustration of the system of the present invention being connected to a data retrieval device.

15 FIGURE 10 sets forth a bottom perspective illustration of a second embodiment showing an information display of the device of the present invention.

20 **BEST MODE FOR CARRYING OUT THE INVENTION AND INDUSTRIAL APPLICATION**

In Figure 1, the electronic medicated dry powder inhalant apparatus 100 of the present invention is shown with main components separated from electronics housing end cap 110. A conventionally available medicated dry powder metered dose inhalant dispenser 140 is
25 fitted onto electronic housing 110 as dotted line 150 indicates, over tubular boss 111 with alignment key slot 112 properly positioned. Note that metered dose inhalant dispenser has an outlet 145 at its top. Activation sheath
30 120 fits over metered dose inhalant dispenser 140 snugly as dotted line 160 indicates and positions alignment keys 121 to properly mate with fluted surfaces 141 of dispenser package. With sheath 120 properly installed, magnet 122
35 (embedded in sheath wall) is aligned with electronics in the housing 110. Sanitation protective cover 130 fits over activation sheath 120 and metered dose inhalant dispenser 140 and attaches to electronics housing 110 to protect the apparatus while unit is not being used. A

more detailed discussion of these components are revealed in Figure 2a - 2f.

In Figure 2a - 2f shows detail on how a conventional medicated dry powder dispenser package is incorporated in the present invention. Figure 2a shows the dispenser package 200 as it is available from the manufacture Astra Pharma Inc., known as Pulmicort Turbuhaler R. Figure 2b is an end planar view of Figure 2a showing the grooved hand grip 205 of end cap 210 for the easy holding of the dispensing package. Figure 2c shows an exploded side planar view of the dispenser package 200 in its three main components; end cap 210, metered dose inhalant dispenser 140, and sanitary cover 220. Metered dose inhalant dispenser 140 has air inlet orifices 215 which shall be discussed later (a second orifice 215 is on other side of dispenser housing not shown).

Figure 2d shows a side planar exploded view of the device of the present invention 100 comprising three main components; electronics housing end cap 110, activation sheath 120 and sanitation cover 130. In Figure 2e is a side planar view of Figure 2d fully assembled and incorporated within, the meter dose dispenser 140 of Figure 2c. The Figure 2f shows an end planar view of Figure 2e showing a grooved hand grip 290 in the electronic housing 110 for the easy holding and operating of the apparatus of the present invention.

Hence, under the teachings of the present invention, is shown in Figure 2a through 2f how a conventional dry powder dispensing package containing medicated metered dose inhaling powder can be incorporated into the device of the present invention to monitor electronically the usage while substantially maintaining a familiar look and feel in a highly miniaturized and portable package. The plastic sanitary cover 220 and end cap 210 are removed from the package 200 as it comes from the manufacturer and discarded. The meter dose dispenser 140 (containing the medicated powder) is placed over tubular boss 111 with key 214 aligned with key slot 112 so as receptive inner

surfaces 216 snugly press fit until surface 217 nearly
abuts electronic housing 140 at surface 252. The
activation sheath 120 is then placed over metered dose
dispenser 140 until surface 261 abuts electronic housing
110 at surface 253. The mouthpiece 219 of metered dose
dispenser 140 protrudes through opening 264 until surface
262 snugly fits around the tapered body of dispenser 140
housing. At this position, an air tight seal exist
between surfaces 263 of the activation sheath 120 and 218
of the metered dose dispenser 140. A detailed operation
of these components and how they interact shall be
discussed later. The sanitary protective cover 130 of the
present invention screws onto electronic housing 110 via
receptive threads 271 and 254 respectively, completing the
miniaturized portable electronic monitoring apparatus 100.

The components; electronic housing 110, activation
sheath 120 and sanitary cover 130 of the present invention
are plastic elements formed in a conventional manner by
those skilled in the art of die and mold making. It is to
be expressly understood that end cap 210 and
cover 220 are discarded as the medication dispensing
package 200 comes from the manufacturer and replaced with
similarly shaped 110 and 130 structures to maintain a
streamlined and familiar look and feel. If the
streamlined feature were to be forgone, the electronics
housing could adjoin conventional dispenser package 200
over end cap 210 with out removing it, or the sanitary
cover 220. In Figure 3a-3f, the electronic housing end
cap 110 of the device 100 is shown in several views, and
cross-sectional views, revealing inner chambers and
passageways. The electronics access cover 300 mates with
electronic housing 110 via receptive threads 301 and 302
providing enclosure of the chamber 320. The cover 300 has
hollow inner space 321 to provide maximum chamber 320 size
when assembled. Notches 303 allow cover 300 to be
tightened fully into housing 110 so as recess 322
accommodates cover wall 304 to be completely flush with
housing. A two prong forked tool or conventional needle

nosed pliers would access notches 303 and be turned either clockwise or counterclockwise to put on or remove cover respectively to gain access into chamber 320 or to close in, as will be discussed later.

5 Ambient air inlet 305 allows air to flow into chamber 320 from both sides of the electronic housing 110 and continue up through air passage 310. This function shall be disclosed more fully in Figures 4 and 5. The communication connector passage 325 connects chamber 315
10 and chamber 320. The chamber 320 holds the electronics assembly of Figure 4 with communication connector protruding through passage 325 so as to be accessible in chamber 315. There is an electronics assembly key notch 340 which aligns the unit for proper orientation during
15 assembly.

We also see more clearly the key slot 112 in tubular boss 111 and the surfaces 252 and 253 in there relationship to the air passageways 305 and 310. These relationship shall be better understood in Figure 5. The
20 key slot 112 has incorporated into it, a magnet 350 and spring 351. As alignment key 214 of the commercially available medication dispenser 140 engages key slot 112, alignment key 214 pushes (in) against magnet and compresses spring 351. If dispenser 140 is removed from
25 tubular boss 111, the spring would force magnet back out. The purpose of the magnet and spring is to detect when dispenser 140 is in place or removed from system and shall be better discussed in Figure 7.

In Figure 4a shows a side view of the electronics
30 assembly 400 comprising; three each multi layer printed circuit boards (PCB) 401 top, 402 middle and 403 bottom, PCB interconnectors 404, electronic circuitry 405, batteries 410, and 411 with battery clips 450 and 451 respectively, communication connector 415, activation
35 sensing elements 435 and 436. PCB 401, 402 and 403 communicate with one another as may be necessary over the multi-pin interconnectors 404. Assembly and disassembly of the PCB's are accomplished through the mating of these

interconnections in a conventional manner as each PCB interconnector has male and female pins and receptive holes as the case may be. In the preferred embodiment, activation sensing elements 435 and 436 are proximity reed switches. These switches responded to mechanically open and close as magnet 122 (embedded in the wall of activation sheath 120 of Figure 1) comes within the proximity of the magnetic field. Sheath 120 is turned (which also turns dispenser 140 by means of alignment keys 121 and fluted surfaces 141) clockwise and counterclockwise to measure-out a dosage of medication within dispenser 140. As this process is taking place, the reed switches response to the magnet passing within the proximity. This operation is detailed later. The printed circuit boards, interconnectors, and proximity reed switches and battery clips are all conventional and are manufactured and available by several sources. These components could easily be fabricated by anyone skilled in the art of miniaturized surface mounted technique.

Figure 4b shows a top view of the assembly 400 indicating the orientation of the major components of circuitry 405 (microprocessor and clock and ram chips are located on the PBC 402). Also are the orientation of interconnectors 404 (which pass through all three PBCs). The external communications connector 415 and activation sensing elements 435, 436 and 437 are on the top surface of PCB 401 as is the main sensing element 425. The PCB assembly alignment key 460 is located on the bottom PCB 403 which aligns assembly 400 to properly fit into chamber 320 of electronics housing 110 as shown in Figure 3, so as to mate with assembly key notch 340. When properly installed, the communications connector 415 would protrude through connector passage 325 to make connection with external connector cable possible within chamber 315. (Note, dispenser is removed to accomplish external connection to 415, which shall be discussed later). The bottom view of assembly 400 is shown in Figure 4c with main system batteries 410 being secured to PCB 403 by

battery clips 450. Batteries 410 are the main power to the device and are two conventional 3.0 volt lithium cells, model number ECR 2430 as manufactured by Eveready Co. Inc., St. Louis, Missouri. Removal of electronic access

5 cover 303, as shown in Figure 3 would allow replacement of batteries 410 when necessary.

The 3.0 volt battery 411 (shown in Figure 4a on the top side of PCB 402), is to power the ram memory if main batteries 410 are ever removed or become low in energy. Battery 411 provides non-volatility to date and time clock and ram circuitry. It is manufactured by Renata in Switzerland and available through Renata Batteries U.S., Dallas, Texas 75207, as part number CR927. This power system assures that all logged records are retained in the ram in the event the main power batteries 410 run down and need to be replaced.

10 The main sensing element 425 is detailed in partial perspective view of Figure 4b. The main sensing element 425 is mounted across a hole 426 in the top PCB 401 via wire leads 440 and 441, and soldered electrically to pads 442 and 443 respectively. The main sensing element 425 in the preferred embodiment is a fast response thermistor manufactured by Betatherm Corporation, 910 Turnpike Road, Shrewbury, MA 01545, as part No. 100K6MCA24. It is to be expressly understood that any conventional sensing scheme using, for example a pressure device or an audio element device, could be used instead of the thermistor arrangement disclosed above and that the approach shown in Figure 4d is exemplary of one approach.

20 In Figure 5, is an illustration showing the device 100 of Figure 2e as it would be used by a patient with sanitation protective cover off, and showing the interrelationships of air passage chambers. Electronics assembly 400 when installed into electronics housing 110 fits tightly in place as PCB 401 abuts housing 110 upper inner surface 505. This tight fit is maintained by access cover 300 pushing against the bottom PCB 403 at cover

surface 510. Note also the PCB 402 abuts housing 110 middle inner surface 515 to fully secure the assembly 400 at each of the three PCB's and to provide isolation between the air passageway 305 and 310 via PCB 401.

5 When metered dose inhalant dispenser 140 is installed, as was previously discussed, onto tubular boss 111 and press fitted down so as surface 217 nearly abuts surface 252, and activation sheath properly installed so as bottom surface 261 abuts housing surface 253, an air
10 tight seal is created at sheath inner surface 263 and the body of dispenser 140 at surface 218. When metered dose inhalant dispenser is properly installed a substantially air tight cavity 520 (which exist all around the outer
15 bottom position of dispenser 140 within the inner bottom portion of sheath) is created.

 In operation, the apparatus 100 with conventional medication metered dose dispenser installed is placed in between the lips of a user at mouthpiece surfaces 219. The user would inhale and in doing so, draw ambient air
20 through the system beginning at inlets 305. The air must pass through PCB 401 at the hole 426 as shown in Figure 4b and 4d (which is oriented 90 degrees from the two inlet 305) within chamber 320 before exiting through air
25 passageways 310 into cavity 520 because of the tight fit of the PCB 401 circumference against housing inner surface 505. The air flow continues up through the inlets 215 (which is again oriented 90 degrees from the two inlet
30 310) of the dispenser 140. Ambient air, once inside the metered dose dispenser 140 passes through inner chamber to "pick-up" a metered dose of dry powder medication before exiting through mouthpiece 219 orifice 145 to be inhaled into the user's mouth. A further discussion of this operation shall be detailed later after disclosure of the electronic function.

35 In Figure 6, sets forth a perspective illustration of an alternate embodiment showing a different manufacturer of conventional dry powder medication inhalant package 640, that is manufactured by Glaxo B.V., Wattbaan 51, 3439

ML Nieuwegein. This configuration dispenser 640 is known as the Diskaler R. The replaceable, eight dosage disk 623 would be inserted into dispenser 640 each time the medication within the eight blister positions where depleted. Electronic housing 610 is affixed to dispenser 640 and with air passageway 605 to mouthpiece 619. The activation cover 620 (shown in the up, activate position) has a puncher pointer 622 which pierces the thin film on blister disk 623 at one position 624 for each time medication is desired. The medication blister disk 623, has eight positions 624 and is installed in dispenser 640 with its activation cover closed (down), and slide draw 621 pulled out in the direction of arrow 622. To advance the disk 623 to each of the eight positions, the slide draw 621 is likewise pulled out and then back in to position an unused blister containing medication dry powder in front of the puncher pointer 622.

In operation, the user would remover sanitation cover 630, position unused blister position 624 by sliding draw 621 out until it abuts a mechanical stop and then back in, then left activation cover 620 with puncher pointer 622 thereon, to pierce the thin film exposing the medication at one of the eight positions 624. Mouthpiece 619 would be placed between user's lips and upon inhaling, would draw the medication dry powder through passageways in dispenser not shown and out orifice 645. Air passageway 605, activation cover 620 and slide draw 621 with disk 623 present are monitored similar in principle by electronics within housing 610 as air passageways 305, activation sheath 120 with dispenser 140 present are monitored by electronics within housing 110.

It is expressly understood that the electronic dry powder medication dispensing monitor and chronolog apparatus 100, although shown here in detail in the preferred embodiment and an alternate embodiment, and may be configured to electronically monitor and chronolog other conventionally manufactured dry powder dispensers as they may become available, and that the present invention

is not limited to the configuration of any particular manufacturer of dispenser of dry powder medication.

In Figure 7 is disclosed a schematic block diagram of the electronic circuitry 405 on printed circuit top 401, middle 402 and bottom 403 boards of the electronic assembly 400. Main system battery 410 supplies a constant source of power to the input of system voltage regulator 750 over regular source line 701. The regulated output of 750 supplies system battery power over common line 702 to proximity reed switches 435, 436 and 437, and is voltage V.B. source 700. Common line 702 is also available to the inputs of electronic switches 740 and 745. The V.B. 700 source is a constant supply of standby power to all essential circuitry (connections not shown) in addition to what is shown, The essential circuitry are components which initialize the process of detecting events and shall be discussed in detail later in this section.

The output of proximity reed switch sensor 435 is connected to condition "set" one-shot 730 over line 729 and further connected to microprocessor 405 I/O port. The output of reed switch sensor 436 is connected to condition "load" one shot 735 over line 734 and further connected to microprocessor 405 I/O port. Likewise, the reed switch sensor 437 output is connected to condition "dispenser present" one-shot 785 over line 784 and further connected to microprocessor 405 I/O port. The output of the "set" one shot 730 is connected to OR circuitry 775 input over line 731. Likewise, the output of the "load" one-shot 735 is connected to the OR circuitry 775 input over line 736. And further the output of the "dispenser present" one-shot 785 in connected to the OR circuitry 775 input over line 786. The output of OR circuitry 775, over common line 739, is connected to control gate of electronic switch 740 and OR circuitry 776 input. The output of 776 is connected to microprocessor 405 interrupt No. 1 (IR1) input 777. The output of electronic switch 740 provides operation power to the system voltage Vcc 705 supply over line 741. The Vcc 705 source provides power to all

circuitry (non standby) which has been shut off to conserve energy. Vcc 705 connection lines are not shown on the schematic block diagram. Once Vcc 705 has been brought up to power as the proceeding paragraphs shall detail, it is latched-on by instruction of the microprocessor as shall be discussed later in this section.

To illustrate the function of the circuitry thus far, when a commercially available medicated dry powder dispenser 140 has been affixed to tubular boss 111 so as to properly engage alignment key 214 into key slot 112, magnet 350 is pushed inwardly compressing spring 351 in the direction of arrow 711. The magnetic field 714 of magnet 350 causes proximity reed switch sensor element 437 to close and standby power V.B. 700 activates condition "dispenser present" one-shot to generate a momentary pulse to OR-ing circuitry 775. This in turn activates electronic switch 740 to provide Vcc power 705 to the system for as long as the duration of the momentary pulse generated by one shot 785 (for example 100 milliseconds). The sheath 120 of the electronic medicated dry powder inhalant chronolog apparatus 100 is rotated with respect to electronics housing 110, either clockwise or counterclockwise, the magnetic field 719 of magnet 122 (which is embedded in the wall of sheath), moves within the proximity of reed switch sensing elements 435 and 336 to cause activation of one or the other. When in the "set" position, V.B. 700 standby voltage is first available on line 729, functions "set" one-shot 730 so as to provide a momentary pulse to the OR-ing circuitry 775, Likewise, if the sheath 120 is rotated with respect to housing 110 in the direction of arrow 718, so as the embedded magnet 122 to be in the proximity of reed switch sensing element 436, magnetic field 719 causes activation of 436 to occur. The standby power V.B. 700 becomes available over line 734 to function the "load" one-shot 735. A momentary pulse output is over line 736 effecting OR circuitry 775 and electronic switch 740 similarly to

one-shot 785 as described earlier to provide system power Vcc 705. The positions "set" and "load", as is determined by sensors 435 and 436 respectively, are indicative of a metered dosage of medication being available to inhale. Further description of these functions shall be described later in the section.

The clock and ram circuit 760 further functions to activate the OR circuitry 775 over line 757. Clock and ram circuitry 760 has its own independent standby power source battery 411. Battery 411 functions to operate the time and date clock at very low levels of energy in addition to maintaining stored data in the ram (random access memory) section of circuitry 760 during periods of main system power Vcc 705 shut-down, as will be fully discussed later. The clock and ram circuit 760 can be pre-programmed to cause a pulse on line 757. This pulse presented to the input of OR circuitry 775 functions to activate electronic switch 740 providing regulated power to Vcc 705 similarly to functions previously described with one-shots 785, 730 and 735. All four of these circuits; 785, 730, 735, and 760 serve in part to activate electronic switch 740 momentarily making system battery voltage available from regulator 750 to energize main system power Vcc 705.

Any time main system power Vcc 705 is activated all associated circuitry which was shut-down to conserve battery energy, comes alive and functions according the rom (read only memory) program stored within microprocessor 405. Upon initialization of microprocessor 405, program instructions command electronic switch 745 to activate over line 744. System regulated voltage is now also provided to Vcc 705 over line 742. The purpose of electronic switch 745, as previously discussed, is to "latch ON" main system power Vcc 705 to all appropriate circuitry to function programmed instructions beyond the momentary pulsing activation interval generated at the output of OR circuitry 775 as was earlier described.

The 3 volt regulator 710 becomes active over line 743

when system Vcc 705 is powered supplying current over lead 440 of fast response thermistor 425. Thermistor 425 is further connected to input of differentiating amplifier 720 on lead 441 and to microprocessor 405 analog to digital (A/D) converter 755 input by line 754. The input of differentiating amplifier 720 is also connected to "ground" potential through current limiting resistor 715 over line 712. Differentiating amplifier 720 output is connected to comparator 725 over line 721. The function of amplifier 720 in part, is to "track" the slope of wave form 713. Comparator 725 outputs square wave signal 727 at threshold 781. The threshold 781 shall be discussed in detail later. Signal 727 is presented to the OR circuitry 776 and the microprocessor 405 I/O over common line 726 similarly as OR circuitry 775 inputs as was described earlier.

Microprocessor 405 once initialized, responds to signals presented at its interrupt inputs IR1 and IR2. IR1 signal over line 777 is indicative of activity generated by proximity reed switch sensing elements 435, 436 and 487, and by the main sensing element 425. The microprocessor 405 will scan I/O ports to see which one of lines 729, 734, 784 or 726 has toggled and shall proceed to predetermined programmed instructions based on which line is active. Additionally, when signal is present on common line 726, microprocessor 405 activates function of its internal A/D converter 755 to be responsive to any analog signal present over line 754. The result of signals, present on 754, 721, and 726, and their characteristics 780, 781, and 782 are due to the activation and dispensing medicated dry powder inhalant, and shall be more detailed later under the operations section of the present invention. The IR2 interrupt input of microprocessor 405 responds to activation generated from the clock function of clock and ram circuit 760 over line 758. This interrupt is indicative of some predetermined programmed instruction, for example, "alarm" to take medication. Line 789 delivers informational data,

instructions and alarm signals from microprocessor 405 to device 790 (which shall be further discussed in Figure 10 herein. Data and address lines 759 are conventionally connected between microprocessor 405 and clock and ram circuit 760, and functions as necessary according to conventional programming technique. Valid event LED (light emitting diode) indicator 765 illuminates when microprocessor 405 toggles output line 764. Current limiting resistor 770 functions to complete LED indicator 765 circuit. Illumination 766 serves as feedback to the user of the electronic inhalant apparatus 100 when optional display/alarm device 790 is not present. It is understood that a tone generator could be substituted for an audible effect instead of the visual effect of the LED 765 circuit or both. Finally communications connector 415 is connected to the microprocessor 405 over by-directional transmit/receive line 738. Connector 415 also provides external system power directly to Vcc 705 (not shown) when an external communications cable is connected to the electronic inhalant apparatus 100 conserving battery life. This feature shall be further discussed in Figure 9.

All components illustrated in schematic block diagram in Figure 7 are representative of functional components and are commonly available in a diversity of configurations by many manufacturers. Such components are easily connected to one another by anyone skilled in the art as set forth in the diagram of Figure 7. It is to be expressly noted that while individual sensor elements have been set forth and discussed for electronics shown in Figure 7, in the preferred embodiment, other sensor elements may be substituted to result in the same function. For example, thermistor sensors 425 which detects change in temperature as ambient air flows through air passages created by the user inhaling and producing wave form 713, could be produced by an audio element (and appropriate associated circuitry) detecting change of sound as air flows in passages in the approximate path of sensing element 425. The signature of

the sound, both sonic and ultrasonic created by first, as the air is drawn into and through the inlets, holes and passages 305, 426, 310, 520 and into 215, second out of mouthpiece 219 and dispensing outlet 145 would have exact and repeatable signature characteristics. Or one further example, pressure or peizo sensors detecting changes in pressure as air flows through said passages in the path of sensor elements 425. These and other sensor element schemes all could be made to produce similar wave forms 713 and 727 and A/D signals present on lines 754, to provide input signals of the present invention. Also, the reed switches 435, 436 or 437 of the preferred embodiment could be hall effect switches or micro switches, for example, producing similar functionality.

In Figure 8, is set forth the flow of logic in the form of a state table concerning the sensing elements for the operation of the electronic circuitry 405. This process is driven according to instruction program code conventionally written as executions recommended by components manufacturer's data sheet recommendations for any desired result as may be capable of the components, and anyone skilled in the art could write such code. In Figure 8, the following occurs. Power off state 800 normally exists in a standby mode. In the event an activity is sensed, such as a detected reed switch 435, 436, or 437 activation, the power off state 800 enters the power on validate state 805 over path 801. It is in this state, that the electronic switch 740 activates system power Vcc 705 to provide momentary power to system to determine the validity of the activation. If proper activation is detected the system would latch electronic switch 745 and enter log event state 810 valid over path 807. If improper activation occurs, the system would shut-down to standby mode power off 800 over path 806. Once event has been logged in state 810, the system would enter idle state 815 and begin a "wait" routine lasting, for example 2 minutes. Here is where the thermistor element 425 is expected to be sensing the

function of the user inhaling. If no activity is sensed, and after the expiration of the wait period, the system would shut-down from the idle state 815 to standby mode power off state 800 over path 817.

5 If the result of signals on lines 726, 721, 754, and their characteristics 780, and 781 meet the criteria wave forms 713 and 727 of Figure 7, indicating an air flow inhalation, the air flow validate state 820 is entered. This sensed activity must be in synchronization with the proper sequencing of reed switch 435 and 436 to enter the log event state 825 as valid over path 821. Else, the system goes back to standby mode power off 800 over path 822. From log event state 825, the system would shut-down to standby mode power off 800 over path 826 if all proper criteria is met. Else, system would enter back to idle state 815 over path 827 to await further activity. All events would be logged in memory complete with date and time, and magnitude of signal present on line 754 indicating the strength of inhalation. If criteria wave form 713 and 727 are not the expectant shape, slope, magnitude and minimum threshold level 781, the system would flash LED/display/alarm as necessary according to system configuration via 765 and/or 790.

It is important to understand that the "validate signals" are part of the management of state 805 and 820, and as such determines if the activation of the apparatus 100 is indicative of medicated inhalant being properly dispensed in user's mouth or otherwise not properly sequenced indicating no medication has been dispensed.

30 From each of the validate state 805 and 820 or, log event states 810 and 825 the system enters into the flash LED/display/alarm state (not shown) to provide feedback of the event to the user before entering back to the power off state 800 for standby shut-down. The flash LED/display/alarm state may be entered directly from the standby 800 mode, as is in the case of clock and ram circuit 760 of Figure 7, would initialize upon a predetermined programmed schedule to remind user to take

35

medication.

5 It should be explicitly understood, that flash LED/
display/alarm state is symbolized as a general system
configuration. It may be as simple as the LED indicator
765 or more complex as display 790 (which shall be
elaborated in second embodiment of Figure 10 in detail),
or may not exist at all. In the later case, upon
completion of logging event, system would return to
standby power off 800. This later case is a zero feedback
10 configuration which is desirable in "blind testing"
patients to serve as medication dispensing behavior
analysis.

15 Importantly, the teachings of the present invention
provides feedback to the user as may be necessary. For
example, apparatus 100 having installed a placebo dry
power dispenser 140, is useful for helping new patients to
get use to the timing in activation of the device and
inhaling. The flash LED/display/alarm and sensor
capability would indicate such feedback as; improper
20 synchronization of inhaling and magnitude, inhaling too
slow or too fast, and inhaling too hard or too soft for
example. All events are monitored and logged. Once the
new patient was comfortable with proper operations of self
administering the inhalant, they could use a less complex
display 765 instead of 790 configuration of the apparatus
100.

30 To illustrate further the sensing elements and
associated circuitry, the power on state 805 would be
entered from standby power 800 over path 801 for each of
the events indicated in time reference 782. Time 782 is
a possible wave form indicating 3 valid recursive
actuations of the electronic inhalant apparatus 100. Note
that each recovery peak 783a, 783b and 783c becomes less
and less from the original starting temperature as is
35 indicated at the start of time at wave form 782 of signal
713. By means of differentiating amplifier 720 in Figure
7, the threshold 781 is proportionally to each descending
starting point of recursive activations 783b and 783c

respectively. Wave form 727 of time 782 indicates that proper threshold criteria has been met for each activation and would have entered air flow validate state 820. This together with signal present on line 754 as interpreted by A/D converter 755 would constitute a valid magnitude of signal indicating a proper inhalation (or less than proper inhalation as the case may be), and log event in state 825. If less than full proper inhalation is discerned, which would be indicated in the feedback flash LED/display/alarm (as may be possible when user does not breathe-in fully, or near fully), would prompt user to inhale through apparatus 100 a second, or in the case of the above illustration a third time. For each of the three activations in the above illustrated example, the full cycle from powering up, validating signals, logging events, and as may be appropriate flashing LED or displaying or alarming, to power shut-down or to wait in idle state 815 would occur between each recursive activation because of the speed and efficiency of electronics assembly 400.

Similarly, when system activation is due to activity responsive to proximity reed switch sensor 437, the power on validate state 805 would be entered and further enter state 810 to log event and give any feedback of event via 765 or 790 as may be appropriate, for example, date and time new dispenser 140 is installed.

When communications connector 415 has been connected to external data retrieval device (disclosed in Figure 9), system enters into communication mode state 830 over path 802 and system becomes responsive to the external commands. The downloading of possible entries would be; interval schedule of medication for auto alarm indication, quantity of dosage, type of medication, and patient's name. The up-loading function would extract all chronologically stored data including an instrument diagnostic report listing sensor behavior and battery supply voltage levels. These features shall be discussed further in the disclosure of the present invention in

Figure 9, 10 and in operations. The powering of system Vcc 705 of Figure 7 is supplied directly from external source via connection to communication connector 415. Once disconnection from communication connector 415 happens, the communications mode state 830 returns back to the power off state 800 and shuts-down to standby mode over path 831.

In Figure 9 the electronic dry powder inhalant chronolog apparatus 100 is shown with the dispenser 140 removed and revealing tubular boss 111. Within tubular boss 111 in chamber 315 is access to the communications connector 415, as identified in Figure 4a and 4b, shown here with external cable 910 and cable connector 905 properly attached to the apparatus. Communications cable 910 and 915 attach to computer 920. The junction 912 illustrates that communication modems may be in the data path transmission over cables 910 and 915 for remote retrieval of chronolog stored records. Computer 920 accesses the data base in the chronolog apparatus 100 for retrieval and analysis of the medication administered and is displayed in tabulated statistical form 925 and graphically as in 930. Such information may be stored in computer memory for combining with other similar chronolog users data and further printed to hard copy utilizing printer 940. Keyboard 935 is manipulated in conventional manner to program apparatus 100 for scheduling if required by doctor. Retrieved information 925 and 930 also could represent a diagnostic report of the apparatus 100 over the full recorded period of time which includes battery and sensor response. This information, under analysis, indicates if the instrument was functioning properly. The computer, printer, cabling and connectors are all conventional and well known and are easily operable by anyone skilled in data handling.

The emphasis here is that positive reporting of prescribed medication is diligently recorded and analyzed to assure the benefits of the medicine doing what the doctor prescribes based on reliable feedback information.

In Figure 10 is shown a second embodiment of the present invention where display/alarm module 790 replaces the electronic access cover 300. This miniaturized module 790 attached to the electronics housing 110 as was similarly disclosed in Figure 3 utilizing threaded surfaces 301 and 322.

The LCD (liquid crystal display) 1035 and push-bottoms 1010 and 1020 are interconnected to microprocessor 405 over wire and connections 1040 conventionally and respond to diverse program routines. One example of such routine is when the user would depress menu selection push-button 1010 until desired option appears in the display 1035, for example (NUMBER OF DOSAGES REMAINING). The user would then depress activate request push button 1020 for the response to the request, for example (50 DOSAGES UNTIL EMPTY) message 1030. The apparatus could know this information if it were programmed with the typical number of metered dosages as is purported by the medication manufacturer. Else the display would simply indicate, for example, (10 DOSAGES USED THIS CONTAINER) as a message 1030. Other example messages are indicated as 1031 and 1032.

It is expressly understood that the type and meaning of messages 1030 and audible alarms 1050 indicated and displayed by module 790 is as varied as medications and concerns that doctors may have, and that the present invention contemplates, and is suited to deliver fully, utilization to satisfy the need.

In operation, the present invention apparatus 100, being miniaturized, portable and having a familiar shape as is in Figure 2e, to users as a non electronic medication inhaler dispensers (Figure 2a), the user would install a conventional medication dry powder dispenser 140 onto electronics housing 110 with sheath 120, all in proper alignment for the dispensing of medication. Proximity reed switch 437 senses the dispenser being present in system and event is logged in non-volatile memory 760.

As user desires a dose of medication, apparatus 100 (which fits easily in palm of hand) oriented up-right as in Figure 5, would rotate electronic housing 110 holding on to grooved hand grips 290, first clockwise with respect to sheath 120, then back counterclockwise to full mechanical stops for each rotation. Then place mouthpiece 219 positioned such within that user's lips around surface of mouthpiece so as to have dispenser outlet 145 directly accessible to user's inner mouth and throat. The user would inhale one metered dose of medication from dispenser 140.

The rotation as indicated above "loads" the metered dose dry powder as a function of dispenser package 140 and in doing so, makes available the medication for inhalation. Sensors 435 and 436 detects this exact procedure. For example, if clockwise rotation to load medication is not fully rotated to engage mechanical stop, reed switch 437 would not activate and no medicated dry powder is available for inhalation. Apparatus 100 would log such "missed" event and if so configured, alert user of improper usage and instruct to repeat procedure.

During powering up, caused by the rotation discussed above, the fast response thermistor element 425 self heats and when the ambient air, caused by inhalation through the apparatus into inlet 305, air passes through air hole 426 of PCB 401, would experience a drop in temperature of the fast response temperature thermistor 425 which would respond to the slightest deviation from its self heating condition. If no air is being drawn through ambient air inlet 305, the rate of temperature would continue to rise, or be steady. The A/D converter 755 monitors these fluctuations and characteristics which determine proper inhalation. A further example, is of a user with little lung capacity, a very low magnitude of inhalation would be sensed, and would prompt the user to inhale a second or third time (as was described in a previous example), to fully "pick-up" all of the medication available in the prescribed dispensed dosage.

The physical time of actuation rotation and inhalation is monitored and system would power down if activity is not fully executed. At the leading edge of the any detected activity, the microprocessor 405 has been initialized and latched operation power via electronic switch 745. Validation of signals generated by the positive rotation to mechanical limits and differentiating amplifier 720 and comparator 725 is processed together with A/D converter 755 signals to determine that positive medication dry powder has been "loaded", and the strength with respect to magnitude of inhalation has occurred.

An important feature of the present invention is expressly understood that the user is identified as positively inhaling the medication by the apparatus as prescribed. This is defined as the medication being administered into the user's mouth as intended in full dosage. For example, the only way to cause a rapid drop of temperature experienced by sensor 425 is to inhale through the apparatus, and the only way to make available a metered dose of dry powder medication is to execute proper rotation of dispenser with respect to electronics housing, thus exact positive monitoring the administration of drugs into the user is achieved and chronologically recorded. The fast response sensor 425 would produce different wave form characteristics than those disclosed in referenced time 780 and on A/D signals of line 754 of Figure 7 if procedure is not exactly adhered to. This is possible by the distinct signature developed by the user drawing ambient air through inlet 305, hole 426, passage 310, cavity 520 and into dispenser inlets 215 before being exited out mouthpiece 219 outlet 145. Thus, if accidental actuation, or misuse of apparatus occurs, appropriate event recording is chronologged and further, complete positive analysis is possible by the prescribing doctor.

While the preferred embodiments of the present invention are disclosed, it is to be understood that modifications and changes may be made thereto and that the present invention is set forth in the flowing claims.

CLAIMS

1. A dry powder inhalant device adapted for mounting
on a conventional medication dry powder dispenser having
5 a mouthpiece incorporated in one end of the dispenser, the
device designed for monitoring prescribed dosage of dry
powder received through the mouthpiece, through the lips
and into the mouth, throat, and respiratory system of a
user of the device, the device comprising:

10 first sensing means for sensing the release of the
dry powder in the dispenser, said first sensing means
mounted inside an electronic housing attached to the
dispenser; and

15 a first signal generating means for determining when
the dry powder is released, said first signal generating
means connected to said first sensing means and to a
display means for displaying each occurrence of the
release of the dry powder.

2. The device as described in claim 1 further
20 including second sensing means for sensing the amount of
air flow from an air inlet in said housing and air flow
received through the mouthpiece, said second sensing means
disposed inside said housing and a second signal
generating means for determining when the air flow is
25 received in said housing when the dry powder is released,
said second signal generating means connected to said
second sensing means and to said display means.

3. The device as described in claim 2 further
including a dry powder dispenser sensing means for sensing
30 when the dry powder dispenser is received and removed,
said dry powder dispenser sensing means connected to said
display means.

4. The device as described in claim 3 further
including computing and recording means in said housing
35 for logging positively when the dry powder is released,
when the air flow is received in said housing and through
the mouthpiece when the dry powder is released, and when
the dry powder dispenser is received and removed.

5. A dry powder inhalant device adapted for mounting on a conventional medication dry powder dispenser having a mouthpiece incorporated in one end of the dispenser, the device designed for monitoring prescribed dosage of dry powder received through the mouthpiece, through the lips and into the mouth, throat, and respiratory system of a user of the device, the device comprising:

an electronic housing releasably attached to the dispenser and having computing and recording means therein;

first sensing means for sensing the release of the dry powder in the dispenser, said first sensing means mounted inside said housing; and

a first signal generating means for determining when the dry powder is released in the dispenser, said first signal generating means connected to said first sensing means and to said computing and recording means for logging positively when the dry powder is released.

6. The device as described in claim 5 further including second sensing means for sensing the amount of air flow from an air inlet in said housing and air flow received through the mouthpiece, said second sensing means disposed inside said housing and a second signal generating means for determining when the air flow is received in said housing when the dry powder is released, said second signal generating means connected to said second sensing means and to said computing and recording means for logging when the air flow is received in said housing and through the mouthpiece and the amount of airflow.

7. The device as described in claim 5 further including a dry powder dispenser sensing means for sensing when the dry powder dispenser is received and removed from said housing, said dry powder dispenser sensing means connected to said computing and recording means for logging when the dry powder dispenser is received and removed.

5 8. The device as described in claim 5 further including programmable display means for displaying the number of dry powder dosages taken, the number of dry powder dosages remaining in the dispenser, the amount of each dry powder dosage received from the dispenser, the amount of air flow received through said housing and the mouthpiece and mixed with the dry powder dosage, and like data, said programmable display means connected to said computing and recording means.

10 9. The device as described in claim 5 further including a remote retrieval and data processing means electrically connected to said computing and recording means for retrieval of chronology stored data such as amount and duration of the dry powder dosages of medication positively dispensed over a period of time and patient related data for analysis by a doctor.

15 10. A dry powder inhalant device adapted for mounting on a conventional medication dry powder dispenser having a mouthpiece incorporated in one end of the dispenser, the dispenser having an activation sheath received around and secured to a portion of the dispenser, the device designed for monitoring prescribed dosage of dry powder received through the mouthpiece, through the lips and into the mouth, throat, and respiratory system of a user of the device, the device comprising:

20 an electronic housing releasably attached to another end of the dispenser and having computing and recording means therein;

25 first sensing means for sensing the release of the dry powder in the dispenser, said first sensing means mounted inside said housing and responding when the sheath and dispenser are properly rotated a fixed distance on said housing;

30 a first signal generating means for determining when the dry powder is released in the dispenser, said first signal generating means connected to said first sensing means and to said computing and recording means for logging positively when the dry powder is released;

second sensing means for sensing air flow from an air inlet in said housing and air flow received through the mouthpiece, said second sensing means disposed inside said housing; and

5 a second signal generating means for determining when the air flow is received in said housing when the dry powder is released, said second signal generating means connected to said second sensing means and to said computing and recording means for logging when the air
10 flow is received in said housing and through the mouthpiece and the amount of airflow.

11. The device as described in claim 10 further including an electronically operated proximity reed switch disposed in said housing for sensing when the dry powder
15 dispenser is received on and removed from said housing, said reed switch connected to said computing and recording means for logging when the dry powder dispenser is received and removed.

12. The device as described in claim 10 further including display means mounted on a portion of an exterior of said housing for displaying the number of dosages dispensed from the dry powder dispenser, the number of dosages remaining in the dry powder dispenser, and like data, said display means connected to said
20 computing and recording means in said housing.

13. The device as described in claim 10 wherein said first sensing means is a first and second proximity reed switch disposed in said housing and responsive to a rotation of the sheath and dispenser a fixed distance in
25 one direction on said housing and a rotation of the sheath and dispenser a fixed distance in an opposite direction.

14. The device as described in claim 10 wherein said second sensing means is a fast response temperature thermistor mounted inside said housing and in an air flow
35 path from the air inlet in said housing to the mouthpiece for sensing the of air flow introduced and mixed with the released dry powder.

15. The device as described in claim 14 wherein said thermistor and computing and recording means provide for positively logging the amount of air flow received through said housing and the mouthpiece when the dry powder is released.

5

16. The device as described in claim 14 wherein said thermistor and computing and recording means provide for positively logging the duration of air flow received through said housing and the mouthpiece when the dry powder is released.

10

15

20

25

30

35

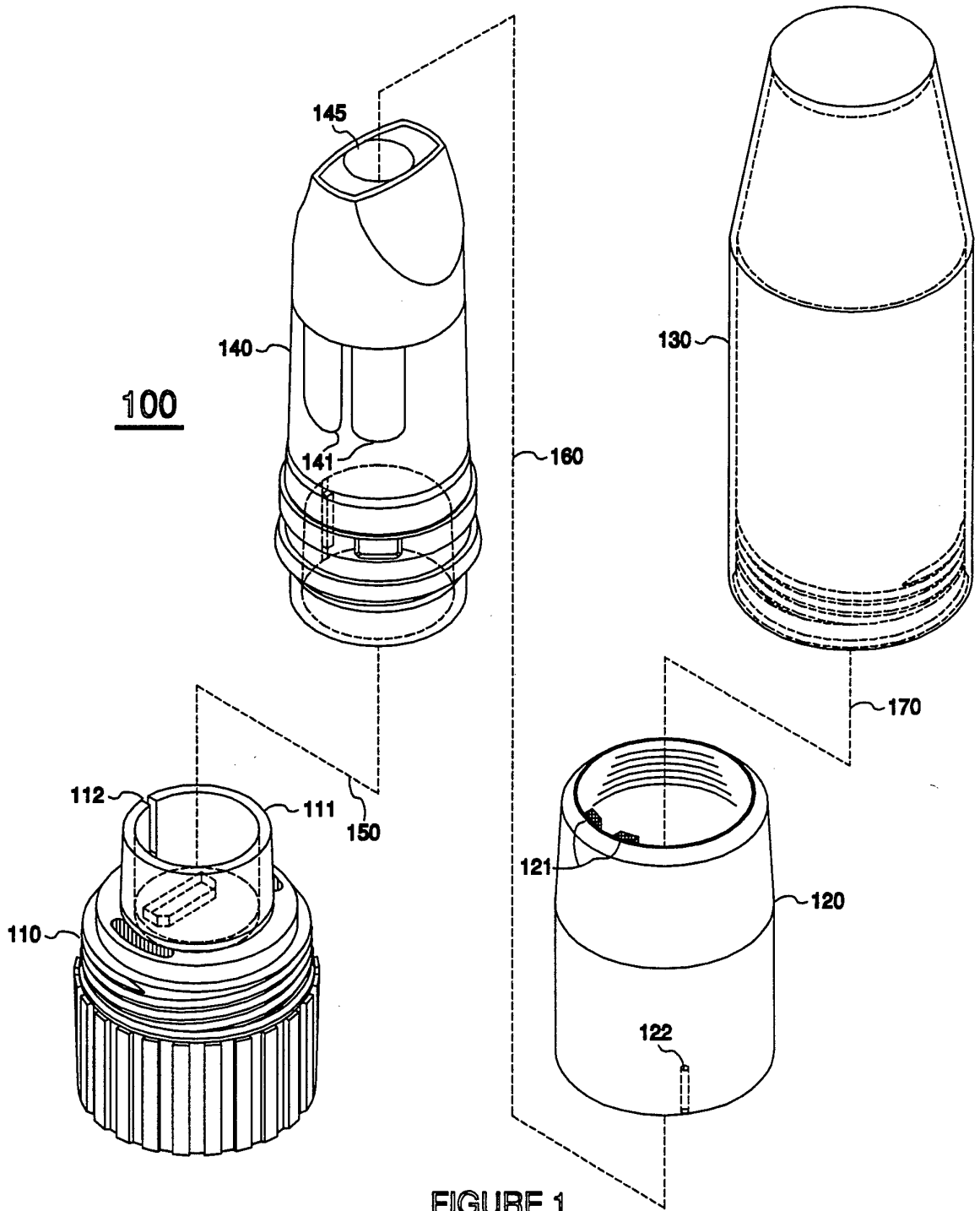

FIGURE 1

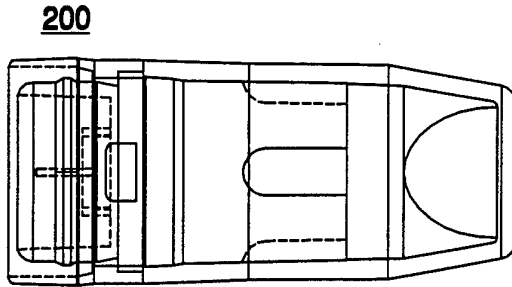

FIGURE 2a

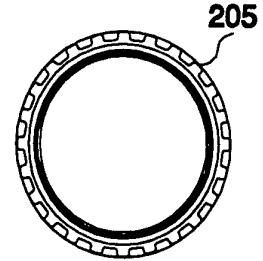

FIGURE 2b

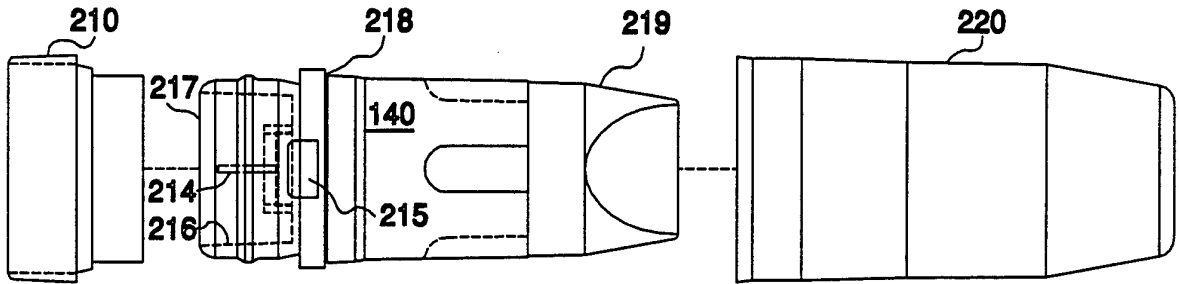

FIGURE 2c

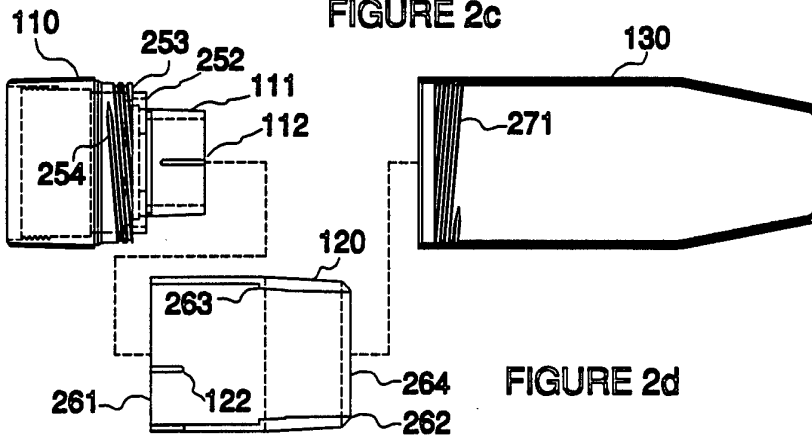

FIGURE 2d

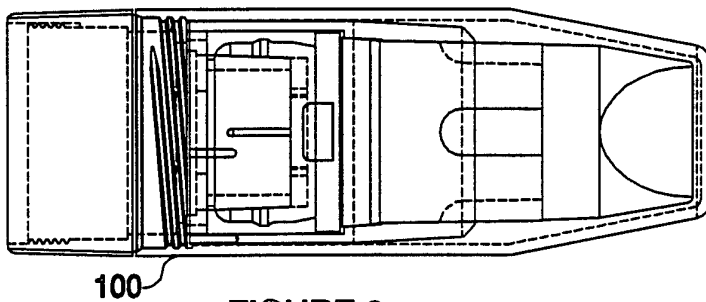

FIGURE 2e

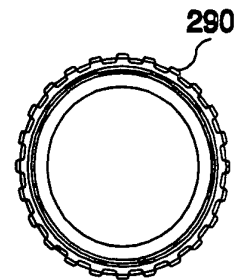

FIGURE 2f

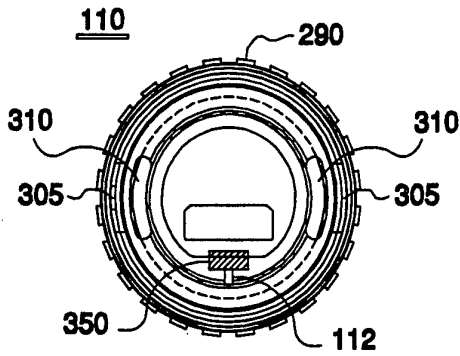

FIGURE 3a

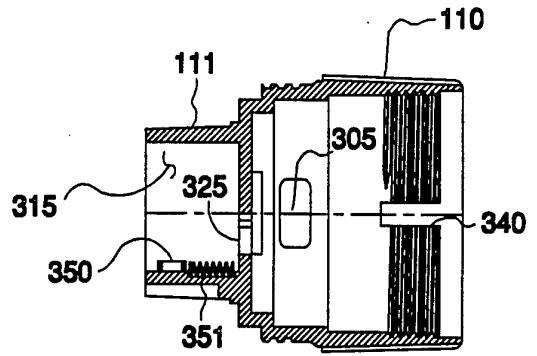

FIGURE 3b

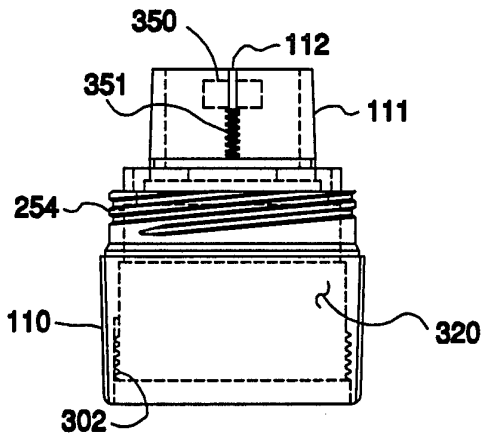

FIGURE 3c

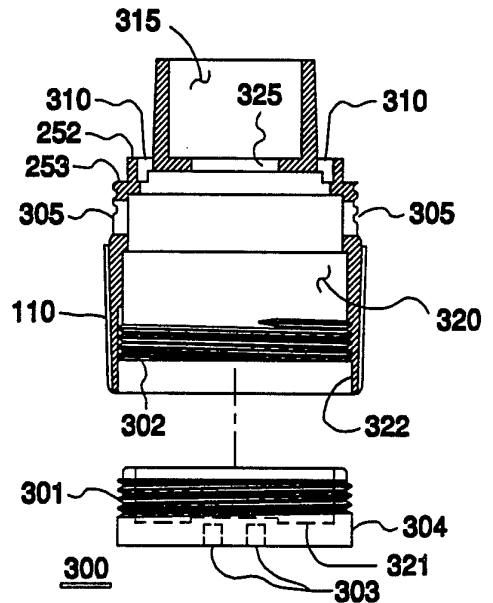

FIGURE 3d

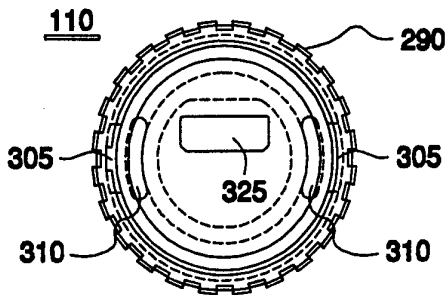

FIGURE 3e

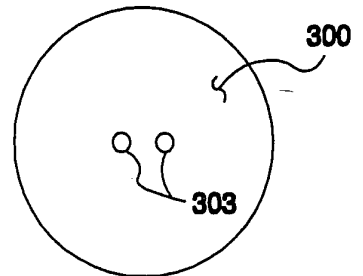

FIGURE 3f

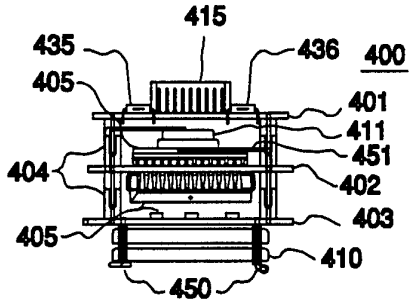

FIGURE 4a

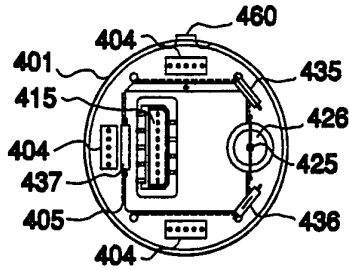

FIGURE 4b

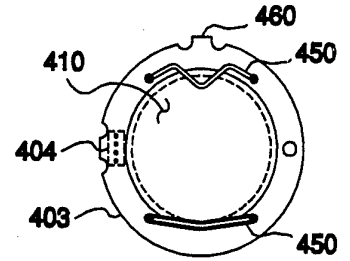

FIGURE 4c

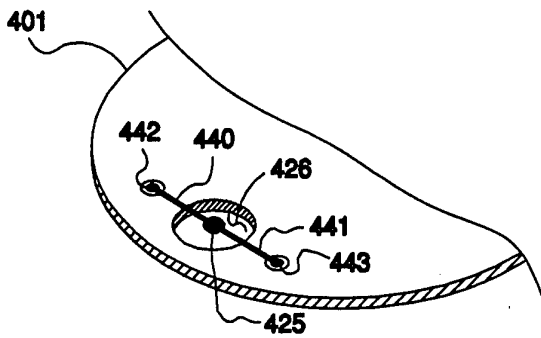

FIGURE 4d

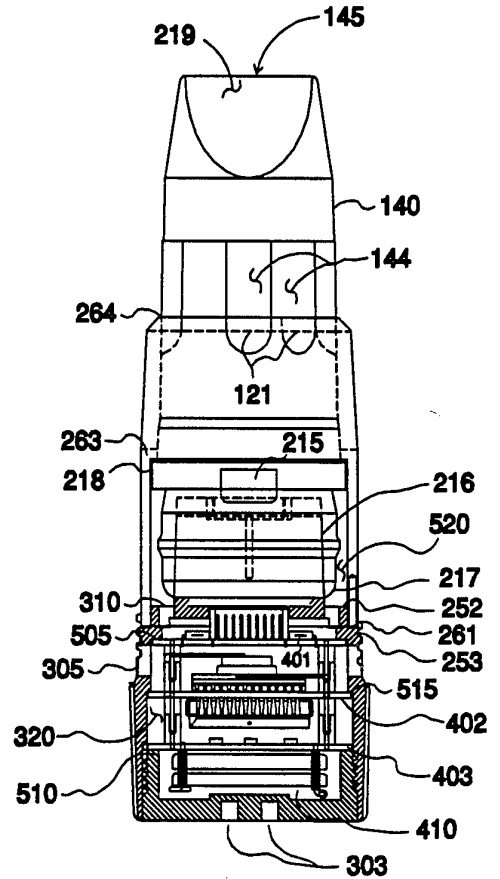

FIGURE 5

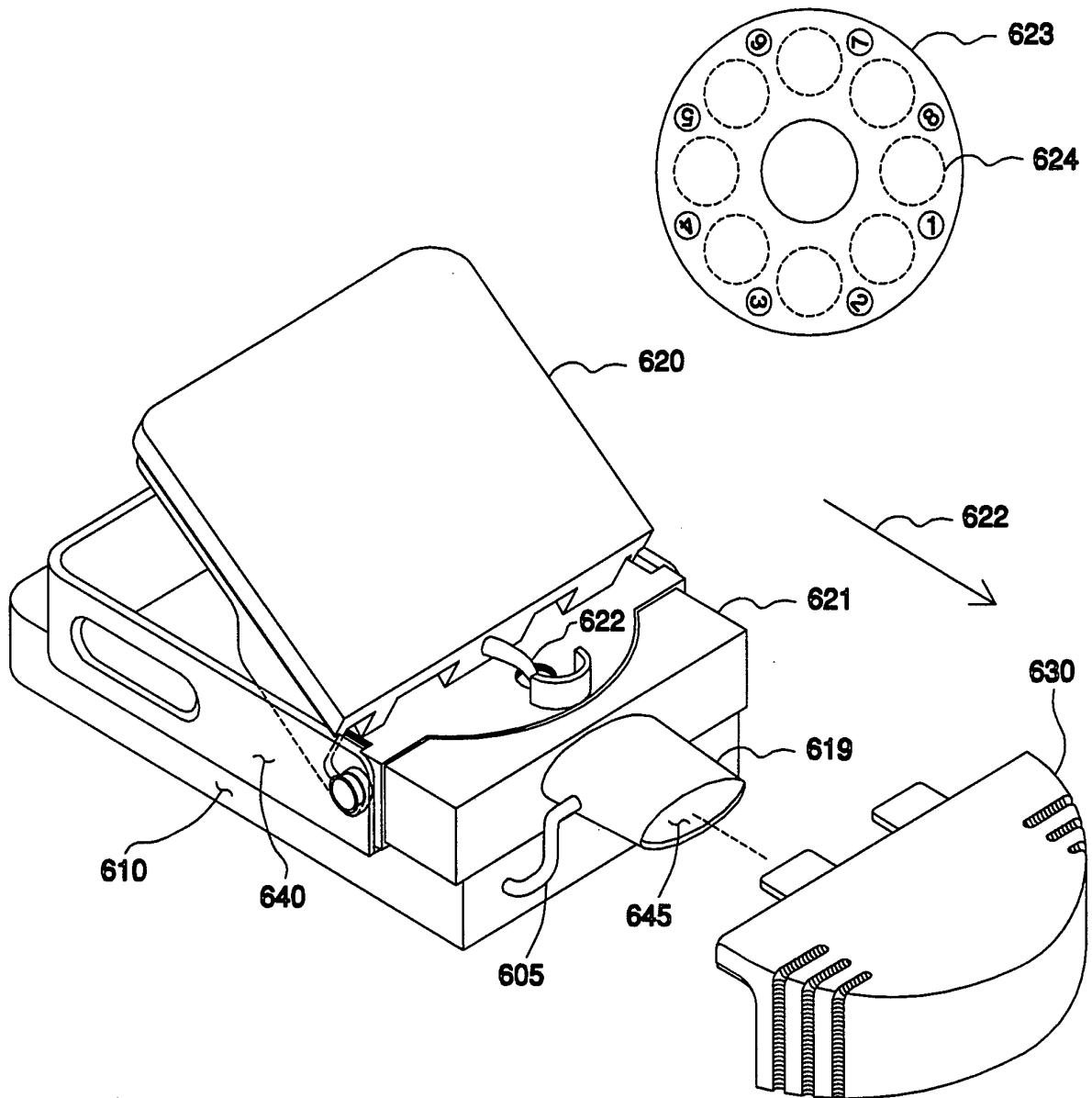

FIGURE 6

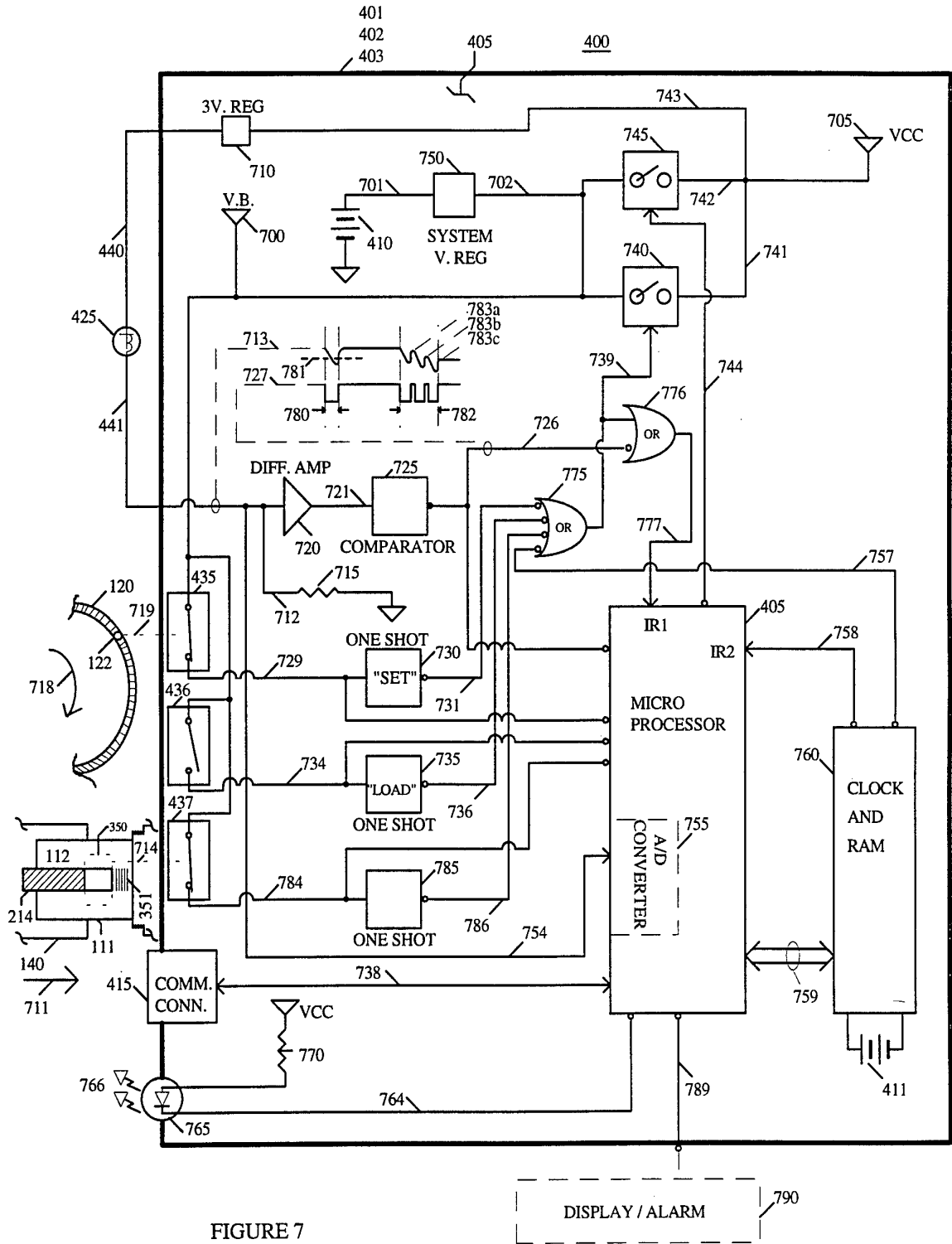

FIGURE 7

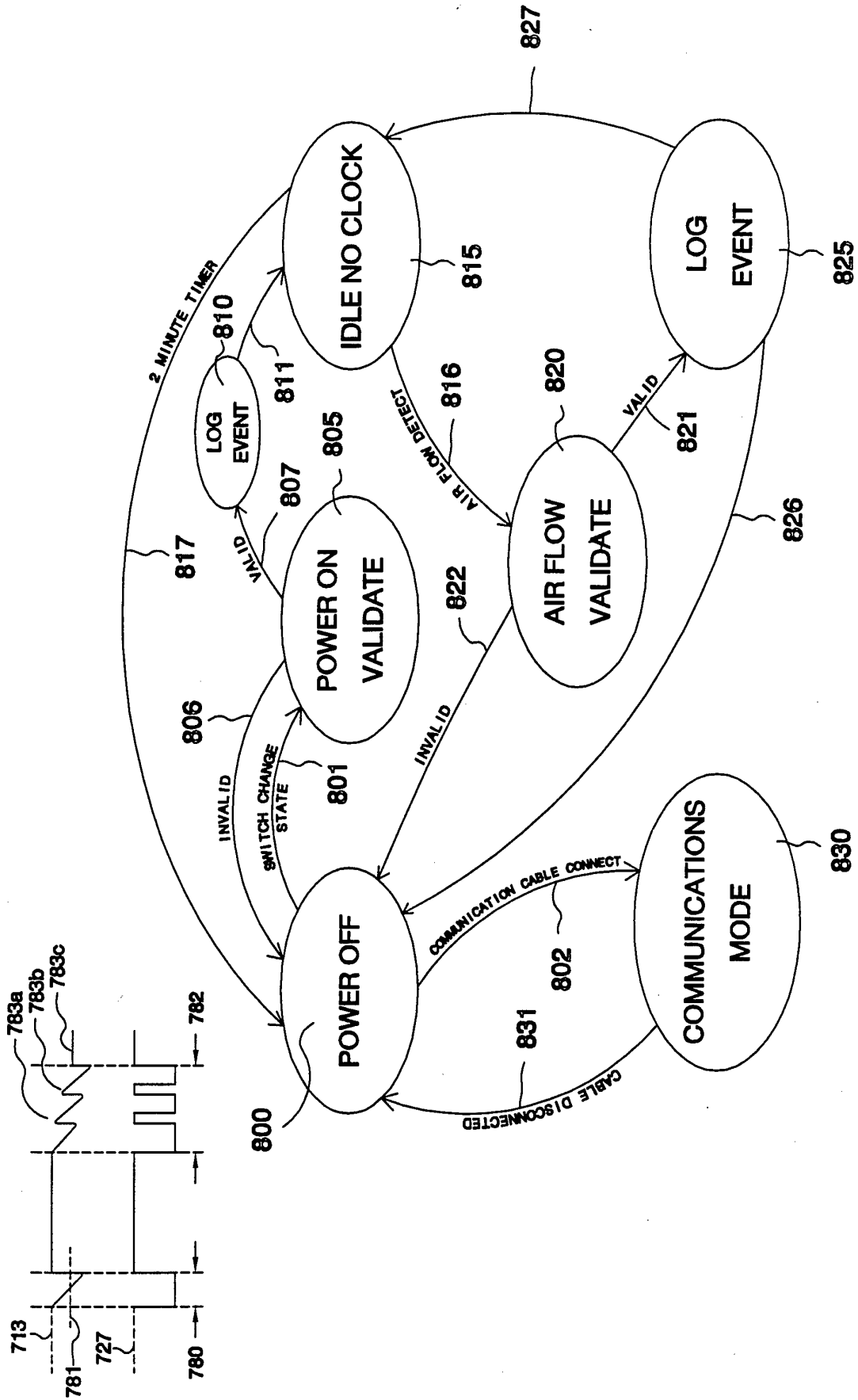

FIGURE 8

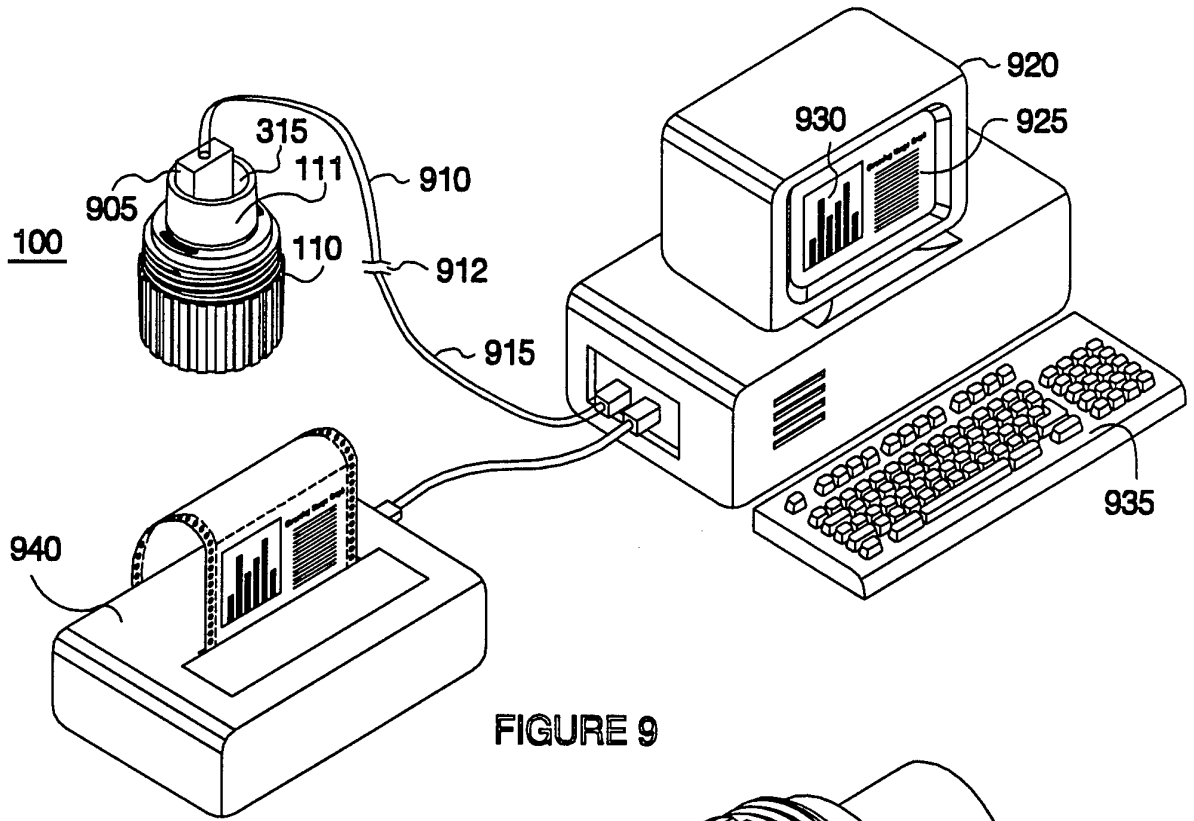

FIGURE 9

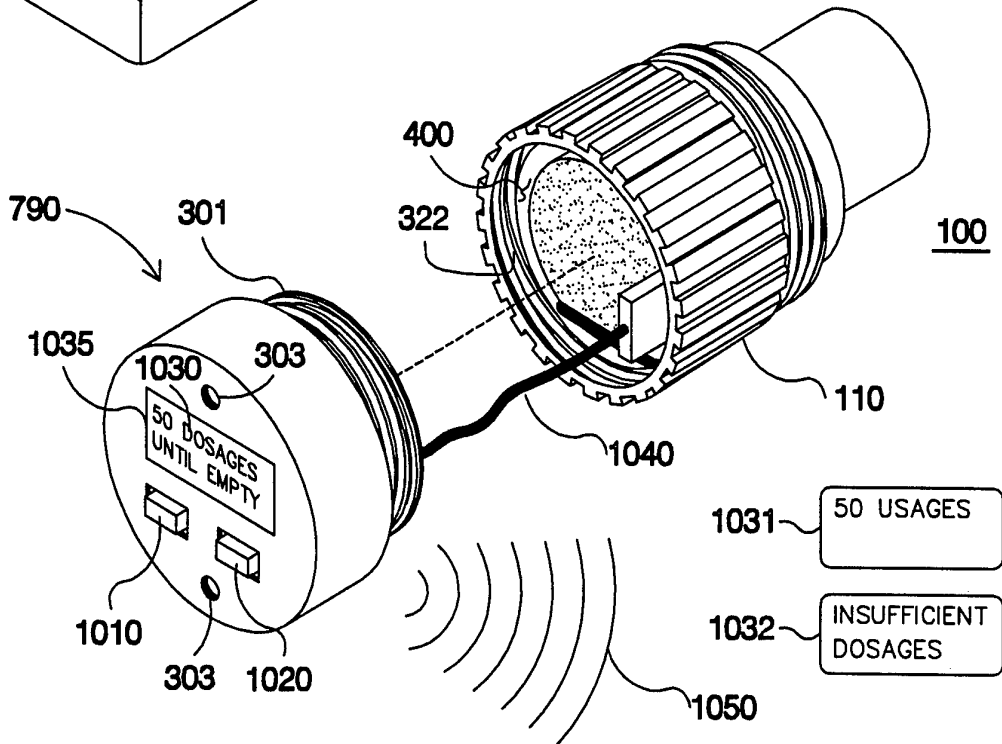

FIGURE 10

INTERNATIONAL SEARCH REPORT

International application No.
PCT/US94/10424

A. CLASSIFICATION OF SUBJECT MATTER
 IPC(5) :A61M 15/00, 16/00; B05D 7/14; B65D 83/06
 US CL :128/203.15
 According to International Patent Classification (IPC) or to both national classification and IPC

B. FIELDS SEARCHED
 Minimum documentation searched (classification system followed by classification symbols)
 U.S. : 128/200/23, 203.12, 203.15, 203.19, 203.21, 203.24

Documentation searched other than minimum documentation to the extent that such documents are included in the fields searched
 NONE

Electronic data base consulted during the international search (name of data base and, where practicable, search terms used)
 NONE

C. DOCUMENTS CONSIDERED TO BE RELEVANT

Category*	Citation of document, with indication, where appropriate, of the relevant passages	Relevant to claim No.
X --- Y	GB, A, 2 262 452, (DAVID KEITH SMITH), 23 June 1993. See entire document.	1-3, 10-16 ----- 4-9
Y	WO, A, WO 92/17231, (KENAN HAVER ET AL), 15 October 1992. See entire document.	4-9

Further documents are listed in the continuation of Box C. See patent family annex.

<p>* Special categories of cited documents:</p> <p>"A" document defining the general state of the art which is not considered to be part of particular relevance</p> <p>"E" earlier document published on or after the international filing date</p> <p>"L" document which may throw doubts on priority claim(s) or which is cited to establish the publication date of another citation or other special reason (as specified)</p> <p>"O" document referring to an oral disclosure, use, exhibition or other means</p> <p>"P" document published prior to the international filing date but later than the priority date claimed</p>	<p>"T" later document published after the international filing date or priority date and not in conflict with the application but cited to understand the principle or theory underlying the invention</p> <p>"X" document of particular relevance; the claimed invention cannot be considered novel or cannot be considered to involve an inventive step when the document is taken alone</p> <p>"Y" document of particular relevance; the claimed invention cannot be considered to involve an inventive step when the document is combined with one or more other such documents, such combination being obvious to a person skilled in the art</p> <p>"&" document member of the same patent family</p>
---	---

Date of the actual completion of the international search 03 NOVEMBER 1994	Date of mailing of the international search report 15 DEC 1994
---	--

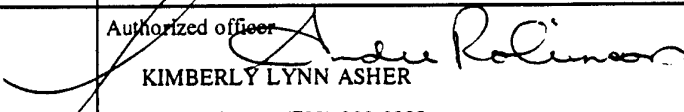
Name and mailing address of the ISA/US Commissioner of Patents and Trademarks Box PCT Washington, D.C. 20231 Facsimile No. (703) 305-3230	Authorized officer  KIMBERLY LYNN ASHER Telephone No. (703) 308-0332
---	--