

(19) World Intellectual Property
Organization
International Bureau



(43) International Publication Date
15 September 2005 (15.09.2005)

PCT

(10) International Publication Number
WO 2005/084578 A1

(51) International Patent Classification⁷: A61C 8/00,
A61B 17/86

(21) International Application Number:
PCT/SE2005/000308

(22) International Filing Date: 3 March 2005 (03.03.2005)

(25) Filing Language: Swedish

(26) Publication Language: English

(30) Priority Data:
0400546-8 5 March 2004 (05.03.2004) SE

(71) Applicant and
(72) Inventor: LUNDGREN, Dan [SE/SE]; Askims Kyrkväg
5, S-436 51 Hovås (SE).

(74) Agents: STRÖM & GULLIKSSON AB et al.; P.O. Box
4188, S-203 13 Malmö (SE).

(81) Designated States (unless otherwise indicated, for every
kind of national protection available): AE, AG, AL, AM,

AT, AU, AZ, BA, BB, BG, BR, BW, BY, BZ, CA, CH, CN,
CO, CR, CU, CZ, DE, DK, DM, DZ, EC, EE, EG, ES, FI,
GB, GD, GE, GH, GM, HR, HU, ID, IL, IN, IS, JP, KE,
KG, KP, KR, KZ, LC, LK, LR, LS, LT, LU, LV, MA, MD,
MG, MK, MN, MW, MX, MZ, NA, NI, NO, NZ, OM, PG,
PH, PL, PT, RO, RU, SC, SD, SE, SG, SK, SL, SM, SY, TJ,
TM, TN, TR, TT, TZ, UA, UG, US, UZ, VC, VN, YU, ZA,
ZM, ZW.

(84) Designated States (unless otherwise indicated, for every
kind of regional protection available): ARIPO (BW, GH,
GM, KE, LS, MW, MZ, NA, SD, SL, SZ, TZ, UG, ZM,
ZW), Eurasian (AM, AZ, BY, KG, KZ, MD, RU, TJ, TM),
European (AT, BE, BG, CH, CY, CZ, DE, DK, EE, ES, FI,
FR, GB, GR, HU, IE, IS, IT, LT, LU, MC, NL, PL, PT, RO,
SE, SI, SK, TR), OAPI (BF, BJ, CF, CG, CI, CM, GA, GN,
GQ, GW, ML, MR, NE, SN, TD, TG).

Published:
— with international search report

For two-letter codes and other abbreviations, refer to the "Guidance Notes on Codes and Abbreviations" appearing at the beginning of each regular issue of the PCT Gazette.

(54) Title: TUBULAR BONE ANCHORING ELEMENT

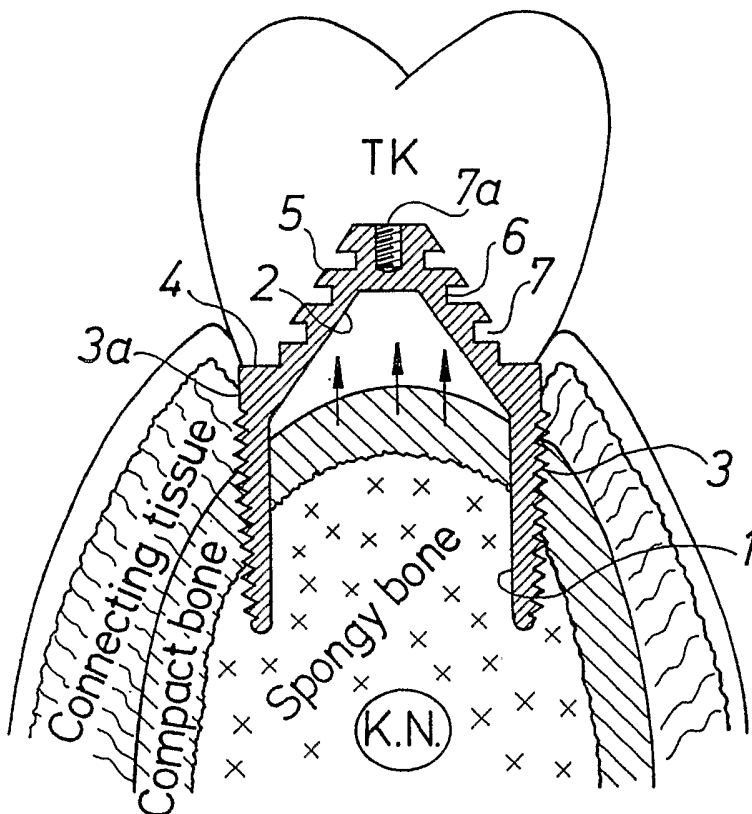

(57) Abstract: A bone anchoring element comprises a tubular implant to be inserted into bone tissue for anchoring a prosthetic component located outside the bone. The implant has a compact, impermeable side wall and is open at one end while the other end is closed by a compact impermeable end wall portion with attachment for prosthetic component on the outside thereof.

WO 2005/084578 A1

Tubular Bone Anchoring Element

The invention relates to a tubular bone anchoring element (implant) for prosthetic constructions.

5 It is previously known to anchor temporarily or permanently for example epitheses and hearing aids as well as tooth crown and tooth bridge constructions by means of oseo-integrated implants, often via extension units, so called abutments, perforating mucous membrane. The implants
10 most often comprise compact threaded screws which are screwed into the bone after a screw hole has been drilled. Either the implants are allowed to be oseo-integrated after covering by mucous membrane and are then connected with abutments after perforation of the mucous membrane, or the
15 implants are connected directly to the abutments thereof or the prosthetic construction.

DT 2628485 A1 describes an arrangement for anchoring artificial teeth as a tubular structure. Both the side wall and the end wall of the tube are perforated so that the lu-
20 men of the tube is in direct connection with the bone tissue outside the tube (see Fig. 19), or the wall is porous to be able to let through liquid and tissue components from the bone as well as covering connective tissue. This involves a very great risk for contamination between the
25 mouth cavity and the lumen of the tube if an infection arises around the implant. If there additionally arises some bone resorption around the implant, as is most often the case the consequences can be devastating for the implant when the infection and bone resorption extend to the
30 lumen of the implant via hollows and porosities in the implant wall. This prior art implant has no threads neither on the inside surface nor on the outside surface of the sidewall but it is stated that there may be a helical ridge on the outside surface. The implant is substantially in-
35 tended to be hacked or pressed down into a trephine-drilled groove. The lumen thereof moreover has a bone contact sur-

face. The implant referred to cannot provide conditions of bone enlargement. Moreover it has preferably an outside diameter of only 4 mm.

A less immediate example of an implant is disclosed
5 in WO 96 19 947. This implant certainly is tubular but only at the apical third part thereof, i.e. the third part most remote from the tooth crown. The upper part located adjacent the tooth crown is compact and is received by a blind hole for a screw attachment for the abutment of the tooth
10 crown. This means that this implant has a small bone contact surface and requires removal of a considerable amount of bone at the insertion of the implant. The small extension of the apical cavity implies that the implant does not provide conditions for bone enlargement. It is not provided
15 with threads neither on the outside surface nor on the inside surface of the sidewall. Also this implant preferably has an outside diameter of only 4 mm.

EP 0 083 558 describes a bone anchoring element comprising a tubular implant to be inserted into bone tissue
20 for anchoring a prosthetic component located outside the bone said implant being open at one end which is intended to be inserted into the bone tissue while the implant at the other end, intended to be directed towards portions located outside the bone tissue is closed by a compact impermeable end wall portion having an attachment for the prosthetic component on the outside thereof the lumen extending
25 from the open end through the total implant to the end wall portion so that the lumen after insertion of the implant in the bone tissue includes at least the total portion of the
30 implant, which is intended to be anchored in the bone tissue.

The bone anchoring element according to the invention is of this kind and the object thereof is to provide a bone anchoring element having exceptional support contact between bone and implant so that there is obtained a great
35

primary stability and a great torsional resistance also at installation in bone tissue having a limited bone height. A secondary object then is to effect the insertion of the implant at a minimum of bone cutting.

5 The bone anchoring element according to the invention as defined in claim 1 is characterized in that the implant has a compact impermeable side wall with an inside or outside stop to be engaged with the bone tissue in order to define an end position for the implant when being inserted
10 into the bone tissue, and that the lumen of the implant includes also a cavity located in the end wall portion and open towards the lumen, the lumen as a consequence thereof having such extension that it after insertion of the implant into the bone will be located also above the bone
15 level established around the implant.

 Due to the shape thereof the implant provides an exceptionally great contact between bone and implant in relation to the length (height) and diameter thereof an exceedingly small removal of bone in connection with the installation of the implant being required. This makes the
20 implant particularly suited for installation in bone tissue having a limited bone height and particularly in situations where the extension of the bone sidewise in relation to the direction of insertion of the implant is relatively large.
25 Due to its shape and potentially large contact surface against adjacent bone the implant will have a unique primary stability and therefore can effectively take up vertical forces as well as side forces immediately after installation of the implant in the bone.

30 Further features of the invention are defined in the dependent claims.

 The inside side wall surface of the implant in the closed end of the tube can form a conical ceiling or a cupola so that the lumen of the tube completely or partly
35 fills the tower which forms the closed portion of the im-

plant. This lumen after the installation of the implant in the bone will be located above the bone level established around the implant. Shortly after insertion of the implant and osseointegration thereof the lumen will be filled by
5 ingrowing bone from the bone surface in the implant tube. That bone ingrowth takes place from bone surfaces bordering on apertures in titanium cupolas or titanium tubes has been shown in a plurality of studies on animals (Lundgren D. et al, 1995, Lundgren AK. 1999) as well as human beings (Hämmerli et al, 1996). By the bone ingrowth the contact surface of the implant against the bone will be further
10 increased in relation to prior art cylindrical tubular or compact implants. The implant presented herein thus can be said to have the unique property to be bone enlarging, i.e. it provides conditions for regeneration of corporal bone in
15 connection with existing bone but outside the original bone contour. This improves also successively anchoring of the implant by enlarged contact surface towards the bone without it being necessary to make use of the deeper portions
20 of the bone.

Summarizing the unique design of the implant thus provides several advantages. These include extremely large bone contact surface and low invasivity, i.e. only relatively superficial bone portions have to be engaged. Moreover, the implant will be anchored substantially in the
25 outer bone layer which has a large proportion of compact bone, i.e. bone with high bone density which increases the primary stability and the torsional resistance, which also is promoted by the extension of the implant sidewise which
30 is also favourable considering the load receiving ability of the implant. The bone building properties of the implant are added to this.

The implant does not require an abutment between the implant and the construction to be anchored by the implant.
35 Preferably the implant has threads on the outside as well

as the inside of the sidewall and are then screwed into the bone. These threads can be synchronized and preferably have double entrances in order to allow screw attachment as rapidly as possible. Alternatively, the total inside side wall surface or parts thereof can be provided with micro threads and also the upper portion of the outside sidewall surface. Studies have shown that micro threads are particularly suitable in order to avoid loss of bone tissue about that portion of the implant which penetrates the bone in the border zone at the overlying soft tissue.

The implant provides a bone contact surface which is at least two times that of a compact cylindrical implant with a corresponding length and diameter. Also in situations with small bone height the implant despite its in that case small length (height) provides a bone contact surface which is substantially larger than that of a conventional cylindrical full-length implant (10 mm) with normal diameter (4 mm) and therefore can easily take up sufficient load in order to support the prosthetic construction.

The implant requires a bone cutting which is only about a fifth to a third of that for a compact cylindrical implant of a corresponding length and diameter and about a fourth to half of that for a compact implant of conventional length and diameter (10 x 4 mm).

A combination of small bone cutting and large bone contact surface provides a bone implant quotient which is substantially greater than that of compact implants. Likely, this provides a greater proprioceptive sensitivity and thus an earlier reaction on applied occlusive forces which should be a protection against mechanical overload.

Location of the implant so that the walls thereof are a tangent to the transition zone between compact and spongy bone moreover causes that the implant during the early integration is not sensitive to too low, spongy bone density (large marrow spaces).

An implant having a large diameter moreover provides a mechanical primary stability which is of importance at immediate loading waiting for the biological bone reaction which takes place after installation of the implant and in
5 the long run secures the osseointegration of the implant.

The large bone contact surface causes that the implant can be inserted into bone with a very low bone height, for example the skull bone and the bone of the lower jaw above the mandibular canal with the vessel nerve
10 string thereof, and the bone of the upper jaw below the jaw cavities.

The tubular shape of the implant by the large bone contact surface provides a superior anchoring and resistance against vertical as well as horizontal forces and the
15 often large diameter thereof provides a special ability to withstand these forces. This means that the implant with good prognosis can be inserted with a substantial inclination in relation to the main force direction.

The tubular shape of the implant with a closed ceiling which after installation of the implant will be located
20 above the bone level established around the implant, means that the implant can form its own bone by the bone inside the implant growing up and filling the space under the ceiling of the implant, which further increases the bone
25 contact of the implant. Alternatively, this space already at the installation of the implant can be filled with cor-poral bone in form of bone particles which are collected in connection with trephine drilling of the implant seat. An-
30 other alternative is to fill the space with a bone substitute possibly mixed with cor-poral bone. These measures are intended to accelerate the establishment of the largest possible bone contact. A further alternative is to supply bone stimulating means such as BMP (bone morphogenetic pro-
35 tein) or other similar bone stimulating means. Further other measures include topographic and/or chemical modifi-

cations of the surface of the implant in general and particularly the inside surface thereof. It is previously known to stimulate to increased and more rapid bone formation by means of such methods. The unique feature of the
5 implant presented herein is however the protected inner environment which minimizes disturbances in form of infections and mechanical influence on the organization of blood coagulation and other healing processes. A plurality of studies have shown that spaces defined by titanium walls
10 and with simultaneous contact with living bone provides the possibility of a consequent bone formation in the entire closed space. Particularly pronounced is this bone formation along the walls of the space and this is true also when the space is located in spongy bone (Lundgren D. et al
15 1995, Lundgren AK. 1999).

The outside diameter of the implant can vary from 4 to 16 mm, preferably from 6 to 10 mm. The length can vary from 2 to 16 mm, preferably from 3 to 8 mm. The implant consists of a material with sufficient biocompatibility and
20 strength in order to be able to permanently anchor tooth crowns, tooth bridges and tooth prostheses or epitheses of different kinds such as hearing aids, substitutes for body portions, transmitters or receivers for electric functions or radio functions. Examples of suitable materials are ce-
25 ramics, metals or plastics or combinations thereof. An actual suitable metal is titanium of suitable quality. The invention also relates to a method for insertion of the implant into bone tissue wherein a recess is established in the bone tissue and the tubular portion of the implant is
30 inserted into the recess and is anchored therein. The implant is inserted into the bone tissue through an opening in soft tissue which covers the bone tissue to a depth in the bone tissue at which the end wall portion of the im-
35 outside the recess.

The tubular implant according to the invention and the method for the insertion thereof in a jaw bone (or another suitable bone) now will be described in more detail reference being made to the accompanying drawings, in which

5 **FIG. 1** is a vertical cross-sectional view of an embodiment of the implant according to the invention, which is inserted into bone tissue covered by soft tissue (connective tissue and epithelium),

10 **FIG. 2** is a similar view as FIG. 1 of an implant according to the invention with extremely small length (height),

FIG. 3 is a view similar to FIG. 2 after integration for some time,

15 **FIG. 4** is a similar view as FIG. 1 and discloses an implant according to the invention installed in a bone cavity after just previously effected tooth extraction,

FIG. 5 is a view of the implant in FIG. 4 with mounted tooth crown,

20 **FIG. 6** is a similar view as FIG. 4 and discloses an implant which is inserted into an alveolus after extraction of a two-root tooth,

FIG. 7 is a view similar to FIG. 6 after the lumen of the implant has been completely filled with bone,

25 **FIG. 8** is vertical cross-sectional view of a tooth in the upper jaw with infected roots and damages in the tooth attachment,

FIG. 9 is a vertical cross-sectional view of the alveolus in FIG. 8 after tooth extraction,

30 **FIG. 10** is a view similar to FIG. 9 with an implant according to the invention inserted into the alveolus,

FIG. 11 is view similar to FIG. 10 after the lumen of the implant having been filled with bone,

FIG. 12 is a vertical cross-sectional view which discloses trephine drilling of bone in the upper jaw,

FIG. 13 is a vertical cross-sectional view which illustrates that a bone pin and a sinus mucous membrane are being hacked up by means of a lifter after the trephine drilling in Fig. 12,

5 **FIG. 14** is a view similar to FIG. 13 with an implant according to the invention screwed in at the location thereof,

FIG. 15 is a view similar to FIG. 14 with the implant completely filled with bone,

10 **FIG. 16** is a transverse cross-sectional view of an upper jaw with jaw cavity after trephine drilling in the jaw bone,

FIG. 17 is a transverse cross-sectional view similar to FIG. 16 during lifting of the jaw cavity mucous membrane by means of a curved lifter,

FIG. 18 is a transverse cross-sectional view similar to FIG. 17 after insertion of an implant according to the invention the implant being filled with bone,

15 **FIG. 19** is a vertical cross-sectional view of an implant according to the state of the art with an attached tooth crown, and

FIG. 20 is a explanatory sketch for contact between bone and implant for different implant types.

In FIG. 1 an embodiment of the implant according to
25 the invention is inserted into bone tissue which is covered by soft tissue (connective tissue and epithelium). It has the shape of a tubular cylinder open downwards with an inner sidewall surface 1 which at the top joins an inner closed ceiling 2 which is shaped as an upwards tapering or
30 truncated cone or a cupola. The inner side wall as well as the cone or cupola shaped ceiling preferably has small horizontal and/or vertical threads or grooves and/or are treated by different means and methods in order to present by modified topography a desired surface roughness, or by
35 chemical influence to present a surface which is particu-

larly attractive for surrounding bone tissue. The outer side wall surface 3 forms threads. In the embodiment shown the outer surface of the cylinder side wall converges slightly towards the lower open end of the cylinder. This side wall surface can, however, also be straight, i.e. non-convergent except in the lowermost portion thereof. In another embodiment both the outer and the inner surface of the side wall are provided with synchronous threads preferably with double entrances for rapid screwing. The two side wall surfaces can also be provided with synchronic micro threads or the inner surface can form micro threads and the outer can form a combination of conventional threads and micro threads these being located on the upper portion of this surface.

The threaded outer surface of the sidewall at the top joins a surface 3a which is smooth or provided with very small horizontal grooves or ridges or has another structure which binds optimally to surrounding soft tissue. In the embodiment shown the outer surface of the side wall is straight but it can also be converging or diverging upwards. Said surface at the top joins a smooth horizontal shoulder 4 on which the actual tooth crown TK rests. The shoulder towards the centre joins an upwards converging surface 5 which forms a tower that at the bottom thereof has six vertical side surfaces 6. The outer surface of the tower is provided with horizontal grooves 7 for cement retention of the tooth crown and terminates at the top in a horizontal plane in which there can be provided a threaded blind hole 7a. The vertical surfaces arranged on the sides of the tower resist rotation of the cemented (and possibly also screw fastened) tooth crown but are also motivated in order that it would be possible to establish a key engagement for screwing the implant into the bone in a rational manner.

Surfaces 1 and 3 of the side wall preferably are given a micro topography which promotes bone formation and bone compacting in connection with the surface as rapidly as possible. This can be achieved by means of grooves and
5 ridges of optimum size or by means of etching, milling, electrolyses treatment or in another way in order to provide the correct "roughness" for maximum bone binding. The surface can also be treated chemically by entrainment of fluor, calcium ions or in another way in order to further
10 improve the binding to adjacent bone tissue.

The tube implant according to the invention avoids to interfere with the mandibular canal knowing to the small length (height) thereof in spite of small bone height.

The implant shall be provided with a stop mark to define an end position for the implant at insertion into the
15 bone tissue. This stop mark can comprise an inside or outside stop shoulder which can be formed by the inside of the end wall and can be engaged with the bone tissue.

The intraoral jaw bone crista often has a generous
20 width when the bone height is small, which favours tubular implants having a large diameter. Such an implant then can be located so that the side wall thereof buccally (towards the cheek) and lingually (towards the tongue) preferably involve the transient zone between the outer cortical (compact)
25 bone and the intermediate spongy (marrow rich) bone. This zone has plenty of bone forming cells and at the same time allows optimum use of the dense, compact bone which in studies has been found to promote stability and torsional resistance of the implant due to the fact that this bone
30 has a more or less continuous contact with the implant (Meredith N. 1997).

The implant in FIG. 2 has very small length (height) in relation to the width thereof. The implant is quite recently screwed into the jaw bone and one observes the space
35 immediately below the ceiling of the implant which has not

yet been filled with bone but contains blood and other healing components from the produced surgical wound in the bone. However, after healing for some time the space will be completely filled with bone, FIG. 3.

5 In FIG. 3 there is shown a tubular implant having the same length as that in FIG. 2 but with larger diameter. The bone B after some weeks to months has grown into the uppermost portion of the lumen of the implant closed at the top in contact with the cone or cupola shaped ceiling and as a
10 consequence thereof the bone contact of the implant has increased further. A tooth crown TK has been cemented to the implant. Observe that the implants according to both FIG. 2 and FIG. 3 are substantially anchored in the outer compact bone.

15 The implant according to the invention can also advantageously be placed directly in a tooth alveolus immediately after tooth extraction or after alveol healing for one or two weeks, which is shown in FIG. 4 where the tubular implant R1 is installed in a bone crista with the alveolus filled with granulation tissue G after a quite recently effected tooth extraction. If the diameter of the
20 implant is adjusted such that the outer diameter thereof is almost as large as or larger than the upper (marginal) diameter of the alveolus the side wall surface of the implant further down (apically) will be surrounded by bone at the
25 inside as well as the outside and eventually will be filled in the lumen thereof by bone ingrowth from the alveolus walls and the alveolus bottom. This is shown in FIG. 5 where the alveolus is completely filled with bone AB as is
30 the entire lumen of the implant including the uppermost portion ÖDB. The implant is provided with a tooth crown TK.

A special advantage of the possibility to place an implant in an alveolus immediately after or in an early stage after tooth extraction is that it is easy to orient
35 oneself both sidewise and along the height. In the side

portion of the upper jaw below the jaw cavities there is the additional advantage that the implant can be anchored in a bone structure which if it is not utilized often tends to be resorbed so that a considerable bone height is lost sometimes so clear that there is no more than one or two millimeters bone left below the jaw cavities.

Teeth which have several roots such as some forward cheek teeth and the majority of the rear cheek teeth generally have such a bone anatomy that it is particularly favourable to a tubular implant of the type presented herein. In alveoli of teeth having several roots there is namely always in the apical (deepest) portion thereof a central bone portion formed as a ridge or a triangle of the bone located between the tooth roots. If compact implants were to be installed in such an alveolus it should either be necessary to place two implants (two-root teeth) or three implants (three-root teeth) or to place an implant having a very large diameter centrally in the alveolus and it would be necessary to remove the bone ridge or bone triangle by drilling. The tubular implant presented herein can be placed centrally in the alveolus while maintaining said bone ridge. This provides a primary stability which is unique and moreover the bone ridge can relatively immediately deliver new bone cells and thus new bone for filling of the lumen of the implant. FIG. 6 discloses an alveolus after extraction of a two-root tooth in bone crista where the implant R1 according to the invention has been installed. According to FIG. 7 the alveolus and the total lumen of the implant are filled with bone, AB and ÖDB.

FIG. 8 discloses a tooth of the upper jaw with infected roots and damages in the tooth attachment. The tooth is extracted and after extraction the alveolus is filled with granulation tissue G just about to heal, FIG. 9. As is shown in FIG. 10 a tubular implant R1 is inserted into the alveolus which is under healing. Eventually the total al-

veolus and the lumen of the implant is filled with bone, FIG. 11.

If one faces a situation with very small bone height under the jaw cavities the tubular implant disclosed herein
5 can be used for lifting the mucous membrane of the jaw cavity simultaneously as the implant is being installed. The procedure is that there is drilled according to FIG. 12 a trephine groove with a trephine drill TR to a position just under the mucous membrane of the jaw cavity. Then, a thin
10 bone layer B is hacked or pressed to the bottom of the groove by means of a lifter L together with the sinus mucous membrane S and the bone cylinder which is attached to the mucous membrane and has been removed from other bone by drilling into the jaw cavity, FIG. 13. Then the implant RJ
15 is installed, FIG. 14, the implant maintaining the mucous membrane with the bone pin in the intended position. If the bone under the jaw cavity as an average is for example 3 mm thick (high) it is easy to install a tubular implant which is 6 mm in length and thus lifts the mucous membrane and
20 the bone pin 3 mm. The space which is then created below the lifted mucous membrane beside the bone pin will be filled with the coagulated blood which transforms into healing tissue (FIG. 15) which rather rapidly will be converted into bone. It is also possible to place corporal
25 bone and bone substitute both in the tubular implant before it is installed and in the bone cavity created below the mucous membrane of the jaw cavity around the implant but bone formation will take place also without these measures. This has been shown i.e. by Lundgren S. et al (2003) with a
30 compact cylindrical implant. They lifted the mucous membrane of the jaw cavity by means of surgical operation with so called window technique where a window is drilled to the jaw cavity via the outer sidewall thereof. The advantages with the implant presented herein is that it is not necessary
35 to open a bone window, that a smaller amount bone has

to be removed by drilling and that a tubular implant having a larger diameter than conventional cylindrical implants, with the side wall surface thereof will be closer to the buccal and lingual side walls of the jaw cavity, which increases the primary stability, and that the implant as such is used for lifting the mucous membrane.

FIG. 16 to 19 disclose a special technique for insertion of the implant according to the invention in the bone of the upper jaw below the jaw cavity and the integration into this jaw bone. The soft tissue which covers the jaw bone (B) has been punched away so that the bone where the implant is to be located (the implant seat) has been uncovered (FIG. 16). In the illustrated example the bone has a relatively smooth surface perpendicularly to the direction for inserting the implant but is not thicker than about 3 mm. After the centre of the implant seat has been marked by means of a small round drill the groove Sp into which the implant is to be screwed is drilled by means of a trephine drill to the desired depth. By means of a lifter having ears the mucous membrane of the jaw cavity is lifted, FIG. 17, and then the trephine groove can be made deeper, so that a tubular implant with a thread height of 6 mm, FIG. 18, can be screwed in to the intended position by means of an implant carrier/tightener which has an inner hex which matches the outer hex surfaces 6 of the tower. The implant is installed with a torsional force which usually amounts to 30 to 40 Ncm. If the implant is not self-tapping a screw tap is needed which either can be double, i.e. can cut in both the outer and the inner wall of the trephine groove, or can cut only in the outer wall. According to illustration by means of arrows in FIG. 18 bone will grow into the base portion of the implant as well as the tower thereof. FIG. 19 discloses the situation after some months when bone tissue fills the total implant over the original bone level of the implant seat.

It should be noted that the trephine drill in some situations can be so dimensioned in relation to the inner sidewall of the implant and the thread tap that there will be a clearance of about 0.1 mm (0.05 + 0.05 mm) between
5 these and the inner bone wall of the groove. This is made in order not to risk that the bone pin (B) will be broken and come loose at drilling if the spongy bone is considered to have very low density or the pin is very narrow. Previous studies have shown that such a small distance does not
10 prevent a normal oseointegration, i.e. intimate healing of the bone tissue directly against the implant wall.

CLAIMS

1. Bone anchoring element comprising a tubular im-
plant to be inserted into bone tissue for anchoring a pros-
thetic component located outside the bone, which is open at
5 one end thereof intended to be inserted into the bone tis-
sue while the other end intended to be directed towards ex-
ternally of the bone tissue located portions is closed by a
compact impermeable end wall portion with attachment for
the prosthetic component on the outside thereof the lumen
10 extending from the open end through the total implant to
the end wall portion so that the lumen after insertion of
the implant into the bone tissue includes at least the en-
tire portion of the implant which is intended to be an-
chored in the bone tissue, characterized in that the im-
15 plant has a compact impermeable side wall with a stop mark
for defining an end position for the implant at insertion
into the bone tissue, and that the lumen of the implant
also includes a cavity in the end wall portion open towards
the lumen so that the lumen has such an extension that it
20 after insertion of the implant into the bone also will be
located above the bone level established around the im-
plant.

2. Bone anchoring element according to claim 1
wherein the stop mark is formed by an inside or outside
25 shoulder which can be engaged with the bone tissue.

3. Bone anchoring element according to claim 2
wherein the shoulder is formed by the inside of the end
wall portion.

4. Bone anchoring according to claim 3, wherein the
30 shoulder is formed by said one end.

5. Bone anchoring element according to any of claims
1 to 4, wherein the side wall forms threads on the outside
or inside thereof.

6. Bone anchoring element according to claim 5 wherein existing outside and inside threads are synchronic macro or micro threads.

7. Bone anchoring element according to claim 5 or 6 wherein the threads have double entrances.

8. Bone anchoring element according to claim 1 wherein the outer and/or inner surface of the side wall has micro topography.

9. Bone anchoring element according to claim 1 wherein the lumen of the implant also includes a cavity located in the end wall portion open towards the lumen so that the lumen has such an extension that it after insertion of the implant into the bone also will be located above the bone level established around the implant.

10. Bone anchoring element according to claim 9 wherein the lumen above the bone level established around the implant has a surface which amounts to at least 20 % of the total surface of the lumen.

11. Bone anchoring element according to claim 1 wherein the total potential bone contact surface is at least double the size of a compact implant having the same external measures.

12. Bone anchoring element according to claim 1 which after insertion occupies a bone volume which is maximum 30 % of the bone volume occupied by a compact implant of corresponding length (height) and diameter.

13. Bone anchoring element according to claim 1 which by the partially closed lumen bordering the bone tissue provides conditions for bone formation and bone compacting in the total lumen resulting in regeneration of bone also above the bone level established around the implant.

14. Bone anchoring element according to claim 1 which by its partially closed lumen bordering the bone tissue provides conditions for protection and reception of corporal bone, bone substitute and/or bone stimulating means in

order to accelerate the bone formation and bone compacting in the entire lumen resulting in regeneration of bone also above the bone level established around the implant.

15. Bone anchoring according to claim 1 wherein the
5 length (height) of the implant is substantially equal to the diameter.

16. Bone anchoring element according to claim 1 wherein the implant has a diameter which is larger than its length (height).

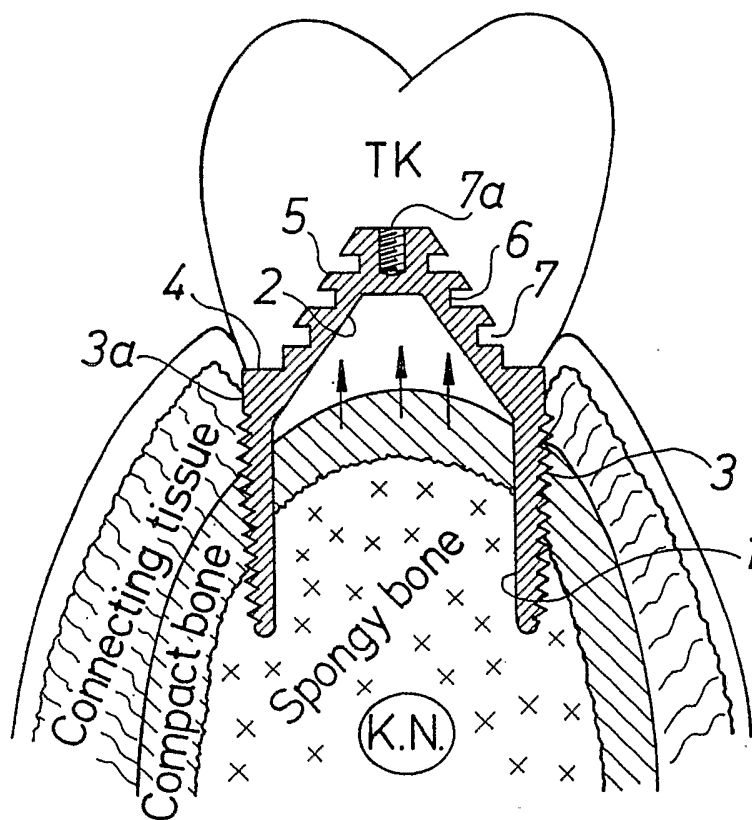

FIG. 1

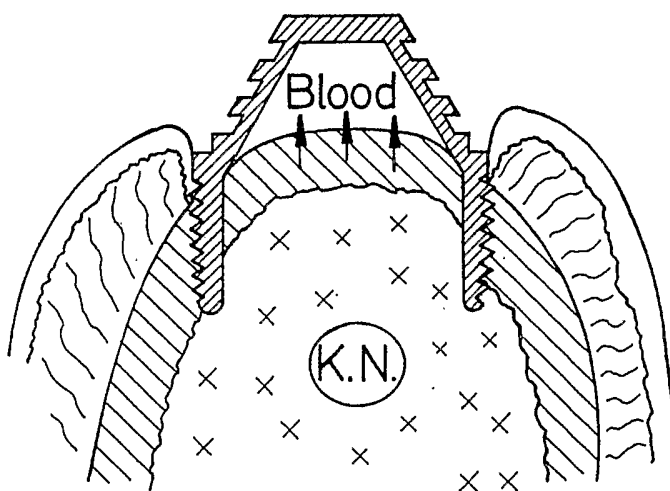

FIG. 2

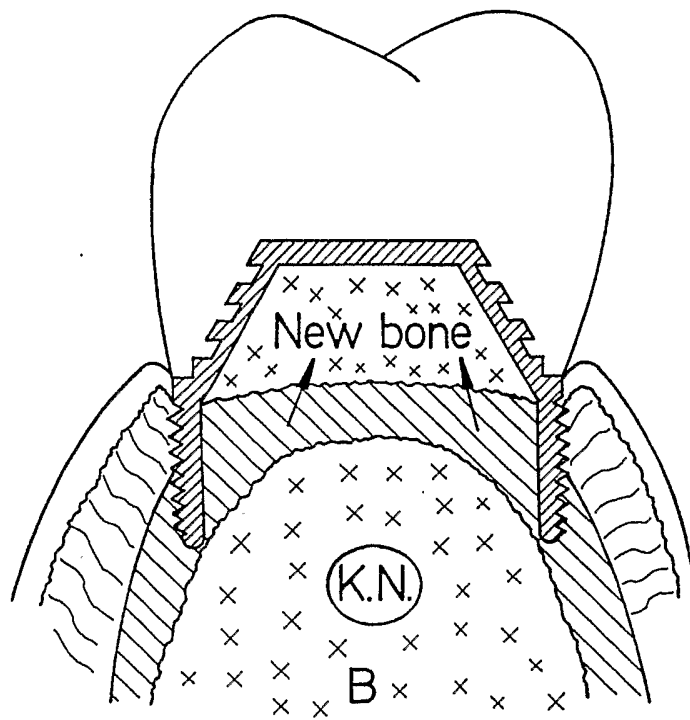

FIG. 3

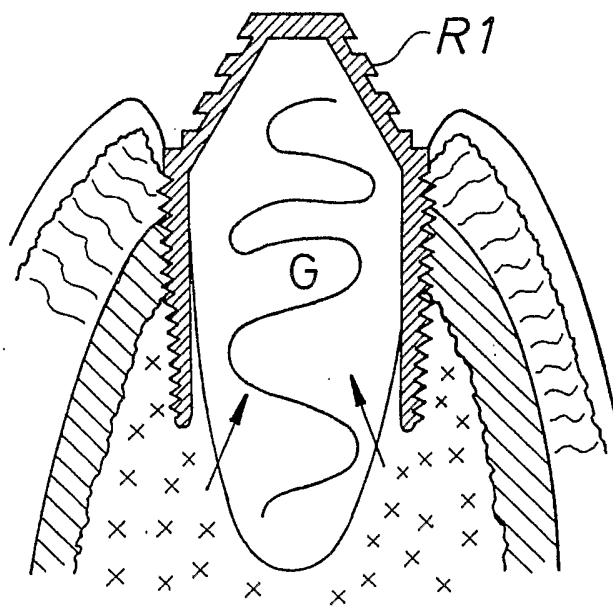

FIG. 4

3/10

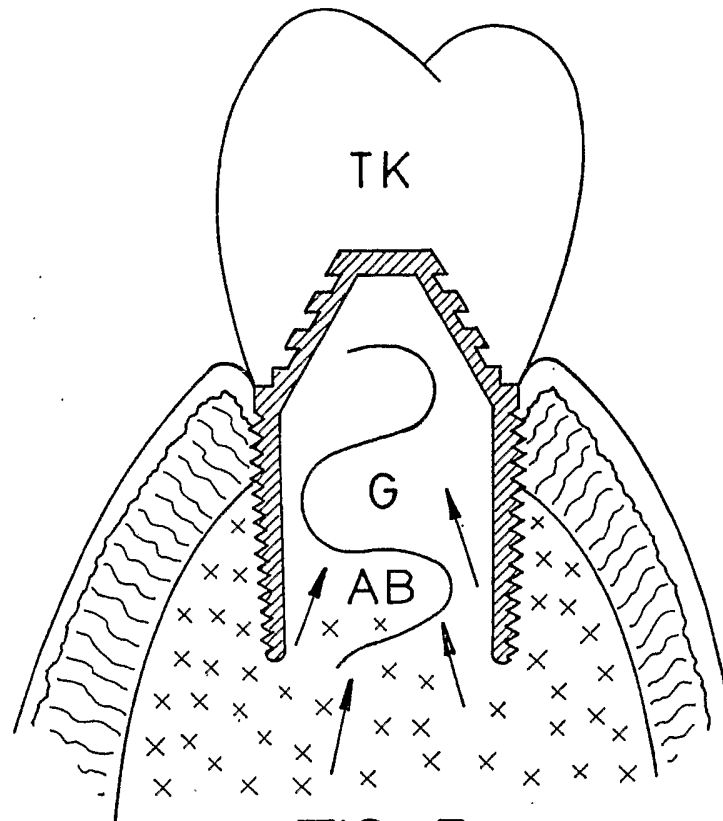

FIG. 5

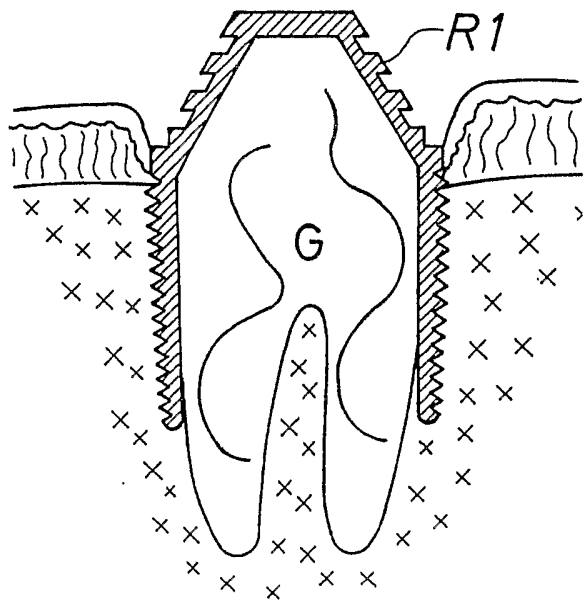

FIG. 6

4/10

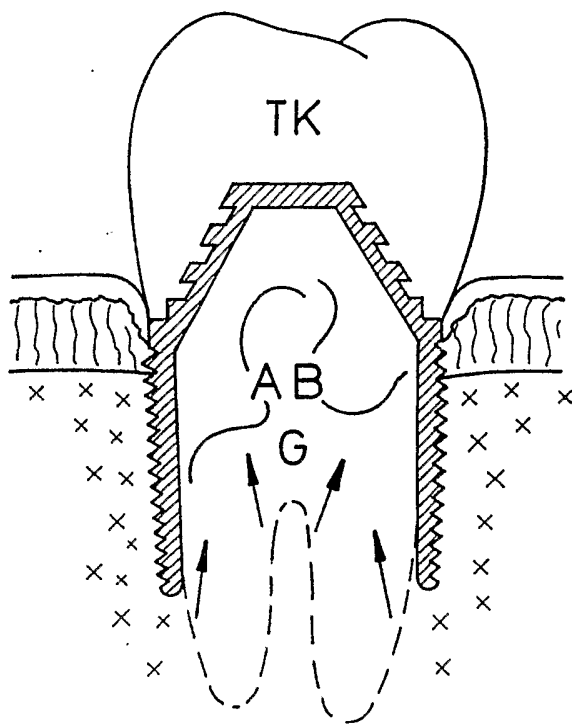

FIG. 7

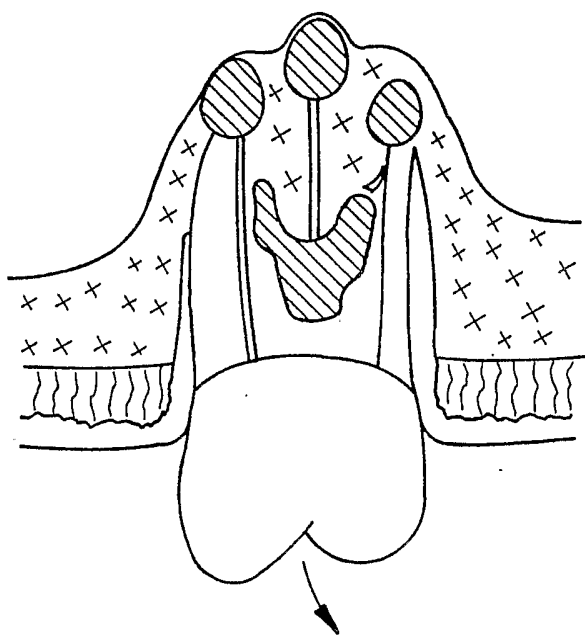

FIG. 8

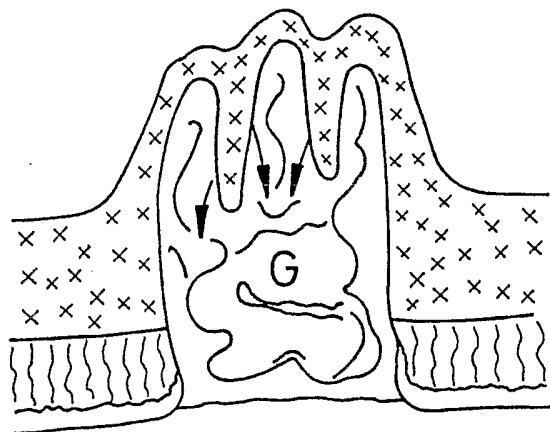

FIG. 9

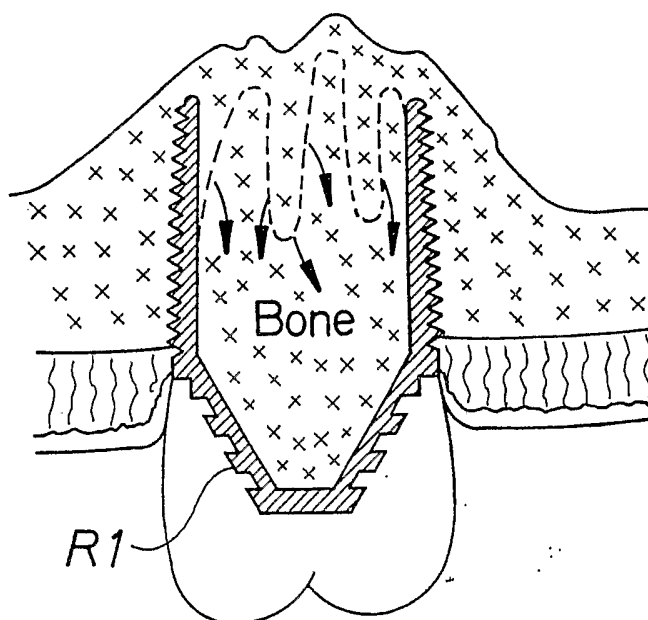

FIG. 10

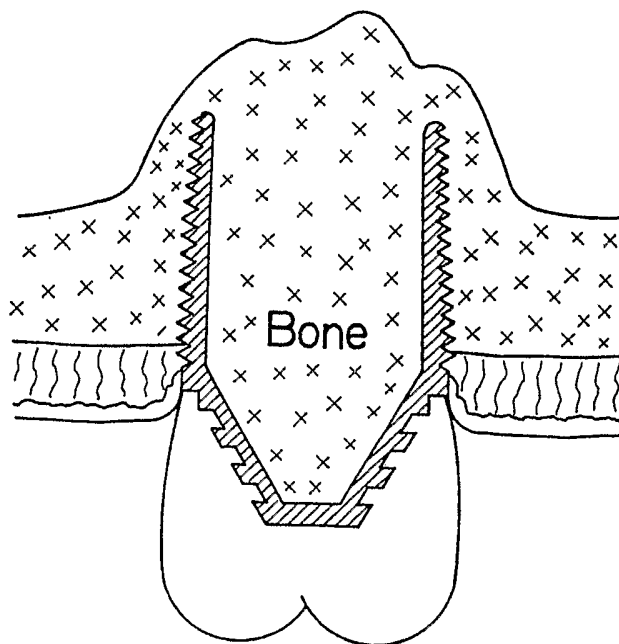

FIG. 11

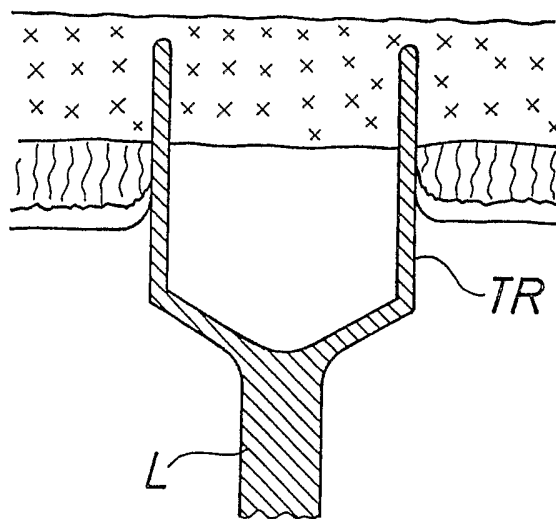

FIG. 12

7/10

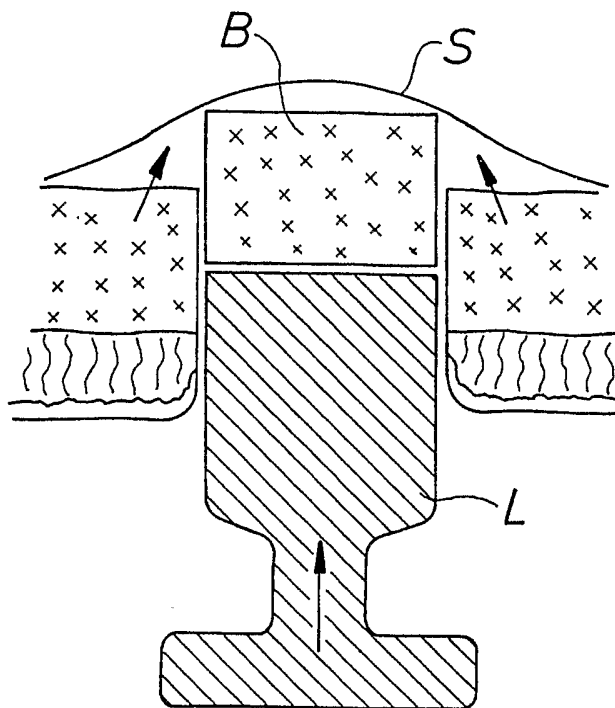

FIG. 13

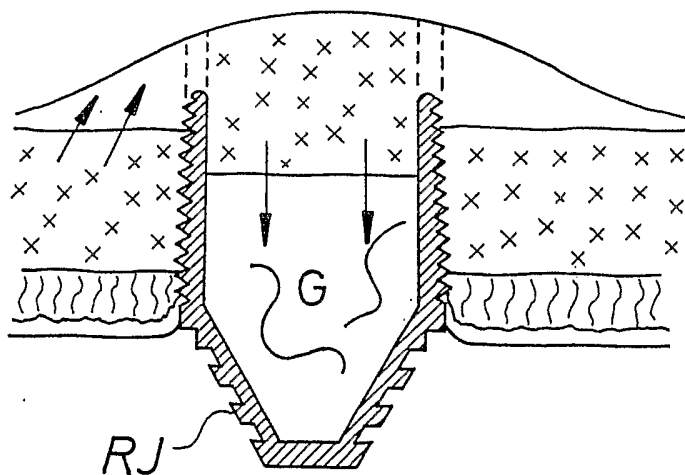

FIG. 14

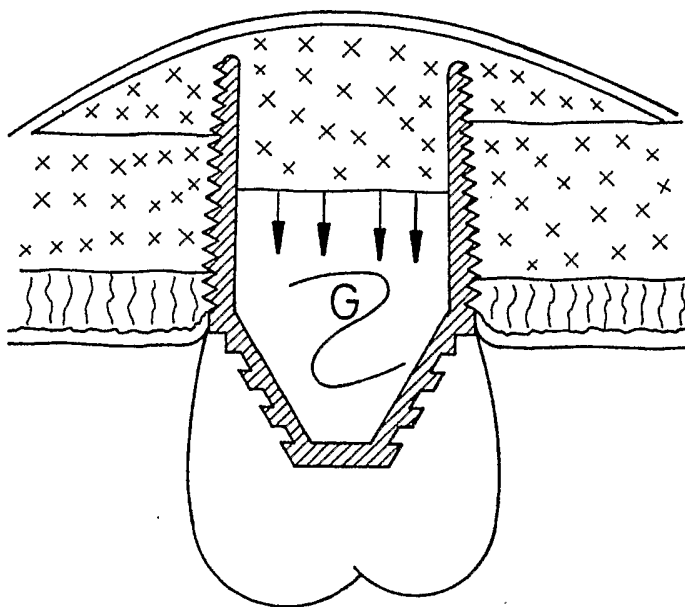

FIG. 15

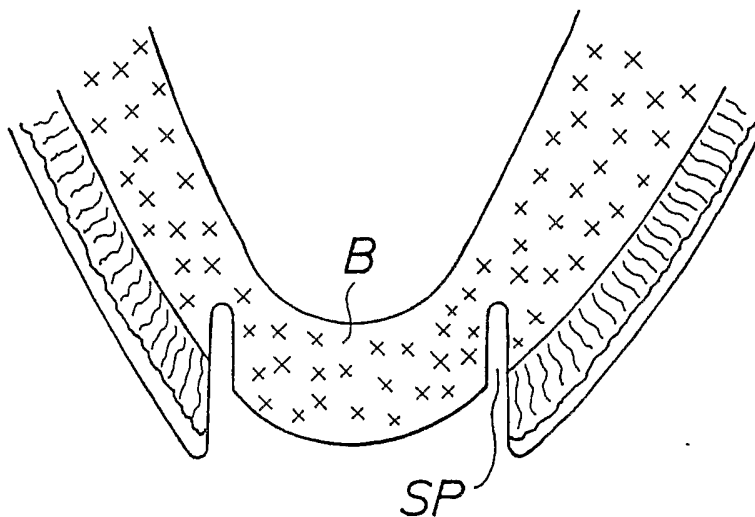

FIG. 16

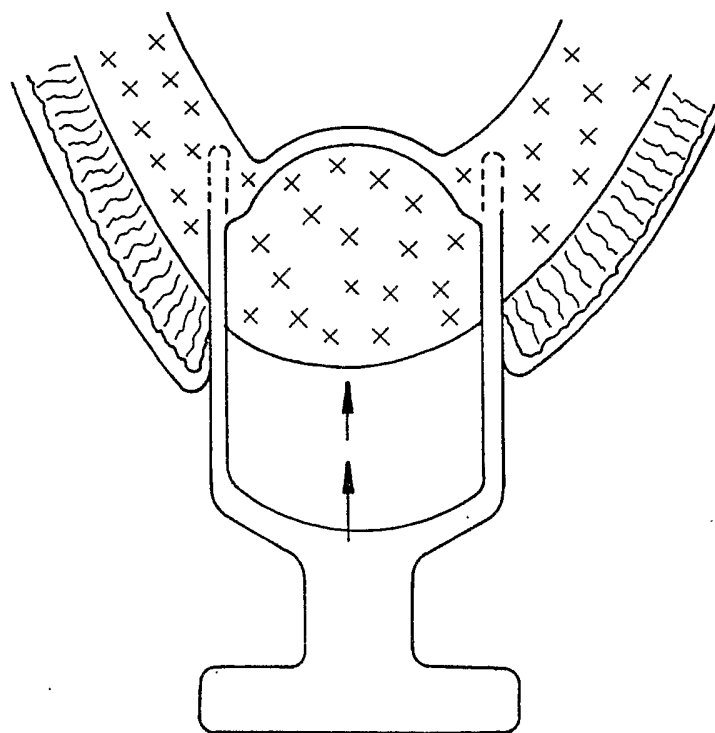

FIG. 17

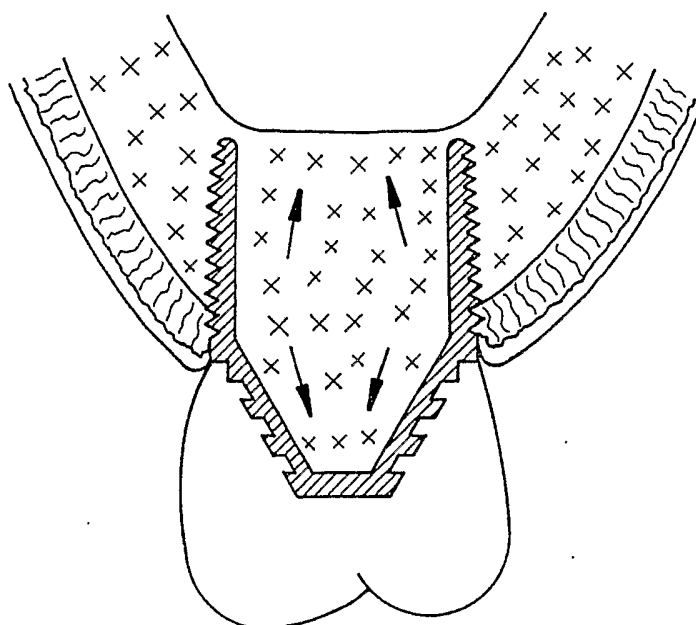

FIG. 18

10/10

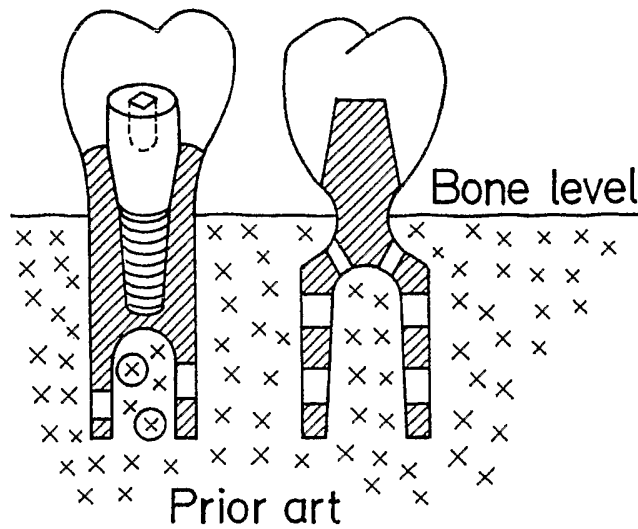
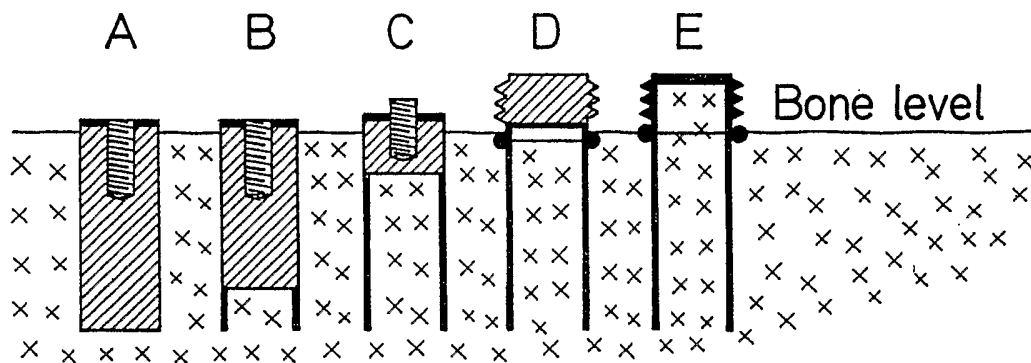

FIG. 19



● = stop marking for D and E

A = compact cylinder ▨ 100 %

B = compact ▨ > 50 % ; tube < 50 %

C = compact ▨ ≈ 20 % ; tube ≈ 80 %

D = tube □ = 100 % according to the invention

E = tube □ > 120 % according to the invention

BIK (bone-implant contact) = E > D > C > B > A

FIG. 20

INTERNATIONAL SEARCH REPORT

In International Application No
PCT/SE2005/000308

A. CLASSIFICATION OF SUBJECT MATTER IPC 7 A61C8/00 A61B17/86				
According to International Patent Classification (IPC) or to both national classification and IPC				
B. FIELDS SEARCHED				
Minimum documentation searched (classification system followed by classification symbols) IPC 7 A61C A61B				
Documentation searched other than minimum documentation to the extent that such documents are included in the fields searched				
Electronic data base consulted during the international search (name of data base and, where practical, search terms used) EPO-Internal				
C. DOCUMENTS CONSIDERED TO BE RELEVANT				
Category °	Citation of document, with indication, where appropriate, of the relevant passages	Relevant to claim No.		
X Y X X	GB 1 203 093 A (EDELMAN AND LINKHOW) 26 August 1970 (1970-08-26) page 2, lines 55-67; figures 1,8 page 3, lines 12-30 figure 3 ----- US 5 433 607 A (SCHMID ET AL) 18 July 1995 (1995-07-18) column 4, lines 52-65; figure 3b column 10, line 68 - column 11, line 23 ----- US 4 531 916 A (SCANTLEBURY ET AL) 30 July 1985 (1985-07-30) column 1, lines 65-68; figures 1,2 column 3, lines 42-46 column 4, lines 30-33 ----- -/--	1-5, 10-14 8,15,16 1-4,8, 11-14 1-4, 11-14		
<input checked="" type="checkbox"/> Further documents are listed in the continuation of box C. <input checked="" type="checkbox"/> Patent family members are listed in annex.				
° Special categories of cited documents :				
<table style="width: 100%; border: none;"> <tr> <td style="width: 50%; border: none; vertical-align: top;"> *A* document defining the general state of the art which is not considered to be of particular relevance *E* earlier document but published on or after the international filing date *L* document which may throw doubts on priority claim(s) or which is cited to establish the publication date of another citation or other special reason (as specified) *O* document referring to an oral disclosure, use, exhibition or other means *P* document published prior to the international filing date but later than the priority date claimed </td> <td style="width: 50%; border: none; vertical-align: top;"> *T* later document published after the international filing date or priority date and not in conflict with the application but cited to understand the principle or theory underlying the invention *X* document of particular relevance; the claimed invention cannot be considered novel or cannot be considered to involve an inventive step when the document is taken alone *Y* document of particular relevance; the claimed invention cannot be considered to involve an inventive step when the document is combined with one or more other such documents, such combination being obvious to a person skilled in the art. *&* document member of the same patent family </td> </tr> </table>			*A* document defining the general state of the art which is not considered to be of particular relevance *E* earlier document but published on or after the international filing date *L* document which may throw doubts on priority claim(s) or which is cited to establish the publication date of another citation or other special reason (as specified) *O* document referring to an oral disclosure, use, exhibition or other means *P* document published prior to the international filing date but later than the priority date claimed	*T* later document published after the international filing date or priority date and not in conflict with the application but cited to understand the principle or theory underlying the invention *X* document of particular relevance; the claimed invention cannot be considered novel or cannot be considered to involve an inventive step when the document is taken alone *Y* document of particular relevance; the claimed invention cannot be considered to involve an inventive step when the document is combined with one or more other such documents, such combination being obvious to a person skilled in the art. *&* document member of the same patent family
A document defining the general state of the art which is not considered to be of particular relevance *E* earlier document but published on or after the international filing date *L* document which may throw doubts on priority claim(s) or which is cited to establish the publication date of another citation or other special reason (as specified) *O* document referring to an oral disclosure, use, exhibition or other means *P* document published prior to the international filing date but later than the priority date claimed	*T* later document published after the international filing date or priority date and not in conflict with the application but cited to understand the principle or theory underlying the invention *X* document of particular relevance; the claimed invention cannot be considered novel or cannot be considered to involve an inventive step when the document is taken alone *Y* document of particular relevance; the claimed invention cannot be considered to involve an inventive step when the document is combined with one or more other such documents, such combination being obvious to a person skilled in the art. *&* document member of the same patent family			
Date of the actual completion of the international search <p style="text-align: center;">13 June 2005</p>	Date of mailing of the international search report <p style="text-align: center;">27/06/2005</p>			
Name and mailing address of the ISA European Patent Office, P.B. 5818 Patentlaan 2 NL - 2280 HV Rijswijk Tel. (+31-70) 340-2040, Tx. 31 651 epo nl, Fax: (+31-70) 340-3016	Authorized officer <p style="text-align: center;">Pypen, C</p>			

INTERNATIONAL SEARCH REPORT

Int	Application No
PCT/SE2005/000308	

C.(Continuation) DOCUMENTS CONSIDERED TO BE RELEVANT

Category °	Citation of document, with indication, where appropriate, of the relevant passages	Relevant to claim No.
Y	US 4 359 318 A (GITTLEMAN ET AL) 16 November 1982 (1982-11-16) column 2, lines 35-38,47-50; figures 1,2 column 2, line 68 - column 3, line 4 column 6, lines 38-49 -----	8,15,16
A	WO 91/14404 A (TITANBRON I AAHUS AB) 3 October 1991 (1991-10-03) the whole document -----	1

FURTHER INFORMATION CONTINUED FROM PCT/ISA/ 210

Continuation of Box II.2

Claims Nos.: 6

The subject-matter of claim 6 relates to synchronic macro or micro threads. This feature is not a commonly used feature and has no well-known meaning. This feature has not been described in the description either. Hence, claim 6 lacks clarity.

The applicant's attention is drawn to the fact that claims relating to inventions in respect of which no international search report has been established need not be the subject of an international preliminary examination (Rule 66.1(e) PCT). The applicant is advised that the EPO policy when acting as an International Preliminary Examining Authority is normally not to carry out a preliminary examination on matter which has not been searched. This is the case irrespective of whether or not the claims are amended following receipt of the search report or during any Chapter II procedure. If the application proceeds into the regional phase before the EPO, the applicant is reminded that a search may be carried out during examination before the EPO (see EPO Guideline C-VI, 8.5), should the problems which led to the Article 17(2) declaration be overcome.

INTERNATIONAL SEARCH REPORT

al application No.
PCT/SE2005/000308

Box II Observations where certain claims were found unsearchable (Continuation of item 2 of first sheet)

This International Search Report has not been established in respect of certain claims under Article 17(2)(a) for the following reasons:

1. Claims Nos.:
because they relate to subject matter not required to be searched by this Authority, namely:

2. Claims Nos.: 6
because they relate to parts of the International Application that do not comply with the prescribed requirements to such an extent that no meaningful International Search can be carried out, specifically:
see FURTHER INFORMATION sheet PCT/ISA/210

3. Claims Nos.:
because they are dependent claims and are not drafted in accordance with the second and third sentences of Rule 6.4(a).

Box III Observations where unity of invention is lacking (Continuation of item 3 of first sheet)

This International Searching Authority found multiple inventions in this international application, as follows:

1. As all required additional search fees were timely paid by the applicant, this International Search Report covers all searchable claims.

2. As all searchable claims could be searched without effort justifying an additional fee, this Authority did not invite payment of any additional fee.

3. As only some of the required additional search fees were timely paid by the applicant, this International Search Report covers only those claims for which fees were paid, specifically claims Nos.:

4. No required additional search fees were timely paid by the applicant. Consequently, this International Search Report is restricted to the invention first mentioned in the claims; it is covered by claims Nos.:

Remark on Protest

- The additional search fees were accompanied by the applicant's protest.
- No protest accompanied the payment of additional search fees.

INTERNATIONAL SEARCH REPORT

 International Application No
 PCT/SE2005/000308

Patent document cited in search report		Publication date	Patent family member(s)	Publication date
GB 1203093	A	26-08-1970	NONE	
US 5433607	A	18-07-1995	CH 687672 A5 DE 4223153 A1 JP 5253247 A US 5306149 A	31-01-1997 21-01-1993 05-10-1993 26-04-1994
US 4531916	A	30-07-1985	AT 37283 T AU 570477 B2 AU 2995484 A CA 1246905 A1 DE 3474106 D1 DK 333184 A EP 0131831 A2 FI 842733 A ,B, GR 82119 A1 IE 55542 B1 JP 1628294 C JP 2052503 B JP 60085739 A NZ 208840 A PT 78856 A ,B ZA 8404873 A	15-10-1988 17-03-1988 10-01-1985 20-12-1988 27-10-1988 09-01-1985 23-01-1985 09-01-1985 13-12-1984 24-10-1990 20-12-1991 13-11-1990 15-05-1985 27-11-1987 01-08-1984 27-03-1985
US 4359318	A	16-11-1982	NONE	
WO 9114404	A	03-10-1991	SE 468339 B AU 7574691 A EP 0592406 A1 JP 5505952 T SE 9001020 A WO 9114404 A1	21-12-1992 21-10-1991 20-04-1994 02-09-1993 22-09-1991 03-10-1991