



(86) Date de dépôt PCT/PCT Filing Date: 2011/08/04
 (87) Date publication PCT/PCT Publication Date: 2012/02/16
 (85) Entrée phase nationale/National Entry: 2013/02/13
 (86) N° demande PCT/PCT Application No.: DK 2011/000090
 (87) N° publication PCT/PCT Publication No.: 2012/019607
 (30) Priorités/Priorities: 2010/08/13 (DK PA 2010 00716);
 2011/03/21 (DK BA 2011 00055)

(51) Cl.Int./Int.Cl. *C14B 1/02* (2006.01),
C14B 1/10 (2006.01), *C14B 15/00* (2006.01)
 (71) Demandeur/Applicant:
 4M GLOBE MANAGEMENT LTD., GB
 (72) Inventeur/Inventor:
 PEDERSEN, KURT, DK
 (74) Agent: MARKS & CLERK

(54) Titre : APPAREIL UTILISABLE EN VUE DU TRAITEMENT DES FOURRURES
 (54) Title: APPARATUS FOR PROCESSING FUR

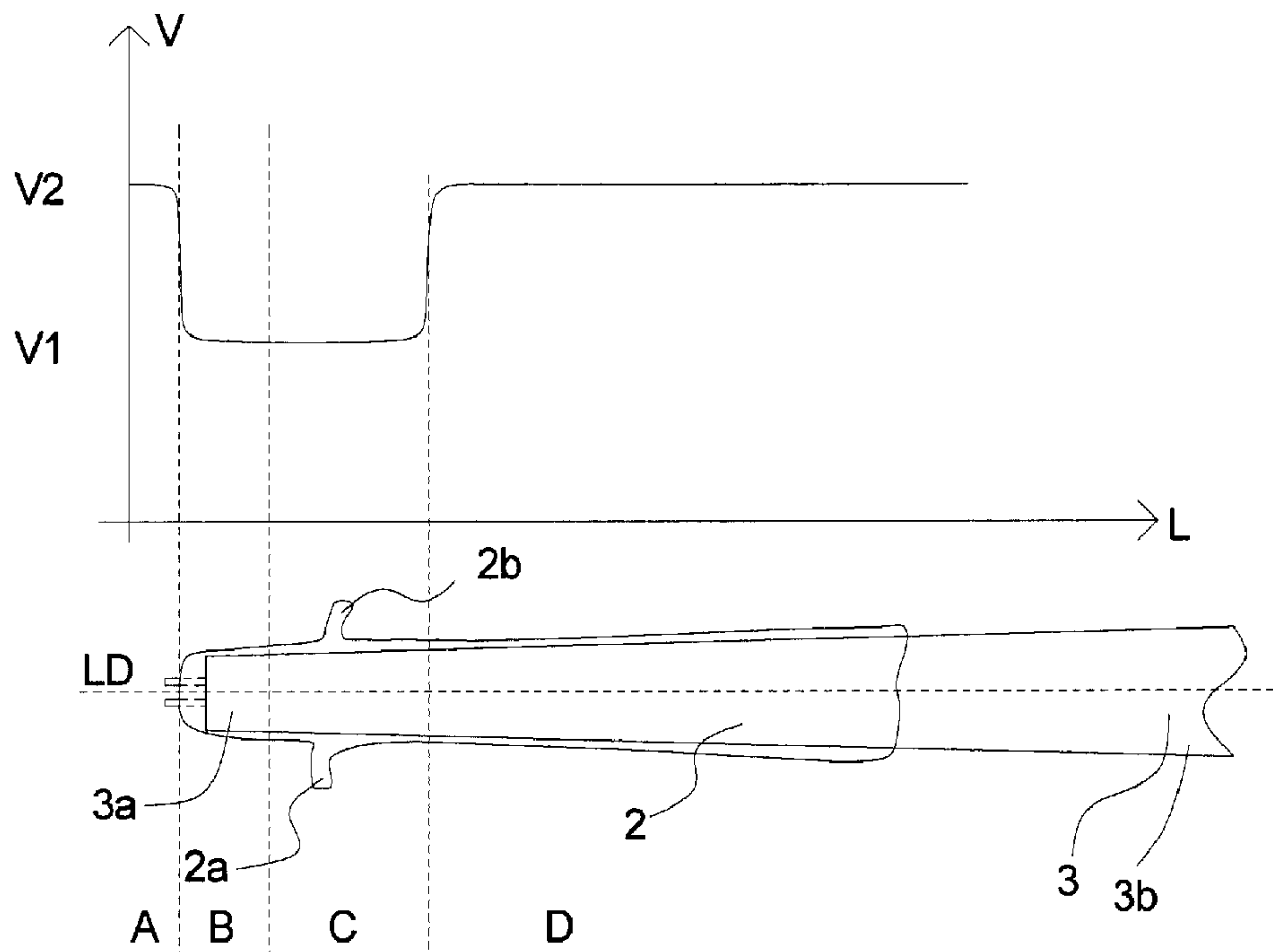

Fig. 6

(57) Abrégé/Abstract:

The invention relates to an apparatus (1) for processing the skin side of a tubular fur (2), which apparatus comprises a tapering mandrel (3) with a first part (3a) that is thinner than a second part (3b) of the mandrel, on which mandrel (3) the tubular fur (2) can



(57) **Abrégé(suite)/Abstract(continued):**

be drawn from the first part of the mandrel (3 a) towards the second part of the mandrel (3b) so that the skin side of the fur (2) faces outwards and the fur side of the fur faces inwards towards the mandrel (3), and at least a first scraper unit (4), comprising at least one scraper roller (4a) which, during operation and in contact with the skin side, is arranged to rotate so that scraping elements (6) on the scraper roller (4a) scrape the skin side of the fur (2). The mandrel (3) is arranged to be driven at different predefined speeds, comprising at least a first predefined speed (V1) and a second predefined speed (V2), where the first predefined speed (V1) is lower than the second predefined speed (V2), and where the apparatus is arranged to switch between the first predefined speed (V1) and the second predefined speed (V2) when the fur (2) on the mandrel (3) is in different predefined positions.

(12) INTERNATIONAL APPLICATION PUBLISHED UNDER THE PATENT COOPERATION TREATY (PCT)

(19) World Intellectual Property Organization
International Bureau(43) International Publication Date
16 February 2012 (16.02.2012)(10) International Publication Number
WO 2012/019607 A1

(51) International Patent Classification:

C14B 1/02 (2006.01) C14B 15/00 (2006.01)
C14B 1/10 (2006.01)

(21) International Application Number:

PCT/DK2011/000090

(22) International Filing Date:

4 August 2011 (04.08.2011)

(25) Filing Language:

English

(26) Publication Language:

English

(30) Priority Data:

PA 2010 00716 13 August 2010 (13.08.2010) DK
BA 2011 00055 21 March 2011 (21.03.2011) DK(71) Applicant (for all designated States except US): **4M GLOBE MANAGEMENT LTD.** [GB/GB]; 7 Lake View, Moor Hall Lane, St. Michael's Mead, Bishop's Stortford, CM23 4GZ (GB).

(72) Inventor; and

(75) Inventor/Applicant (for US only): **PEDERSEN, Kurt** [DK/DK]; Bøgevej 3, DK-7830 Vinderup (DK).(74) Agent: **PATENTGRUPPEN A/S**; Aaboulevarden 31, DK-8000 Aarhus C (DK).

(81) Designated States (unless otherwise indicated, for every kind of national protection available): AE, AG, AL, AM,

AO, AT, AU, AZ, BA, BB, BG, BH, BR, BW, BY, BZ, CA, CH, CL, CN, CO, CR, CU, CZ, DE, DK, DM, DO, DZ, EC, EE, EG, ES, FI, GB, GD, GE, GH, GM, GT, HN, HR, HU, ID, IL, IN, IS, JP, KE, KG, KM, KN, KP, KR, KZ, LA, LC, LK, LR, LS, LT, LU, LY, MA, MD, ME, MG, MK, MN, MW, MX, MY, MZ, NA, NG, NI, NO, NZ, OM, PE, PG, PH, PL, PT, QA, RO, RS, RU, SC, SD, SE, SG, SK, SL, SM, ST, SV, SY, TH, TJ, TM, TN, TR, TT, TZ, UA, UG, US, UZ, VC, VN, ZA, ZM, ZW.

(84) Designated States (unless otherwise indicated, for every kind of regional protection available): ARIPO (BW, GH, GM, KE, LR, LS, MW, MZ, NA, SD, SL, SZ, TZ, UG, ZM, ZW), Eurasian (AM, AZ, BY, KG, KZ, MD, RU, TJ, TM), European (AL, AT, BE, BG, CH, CY, CZ, DE, DK, EE, ES, FI, FR, GB, GR, HR, HU, IE, IS, IT, LT, LU, LV, MC, MK, MT, NL, NO, PL, PT, RO, RS, SE, SI, SK, SM, TR), OAPI (BF, BJ, CF, CG, CI, CM, GA, GN, GQ, GW, ML, MR, NE, SN, TD, TG).

Declarations under Rule 4.17:

— of inventorship (Rule 4.17(iv))

Published:

— with international search report (Art. 21(3))

(54) Title: APPARATUS FOR PROCESSING FUR

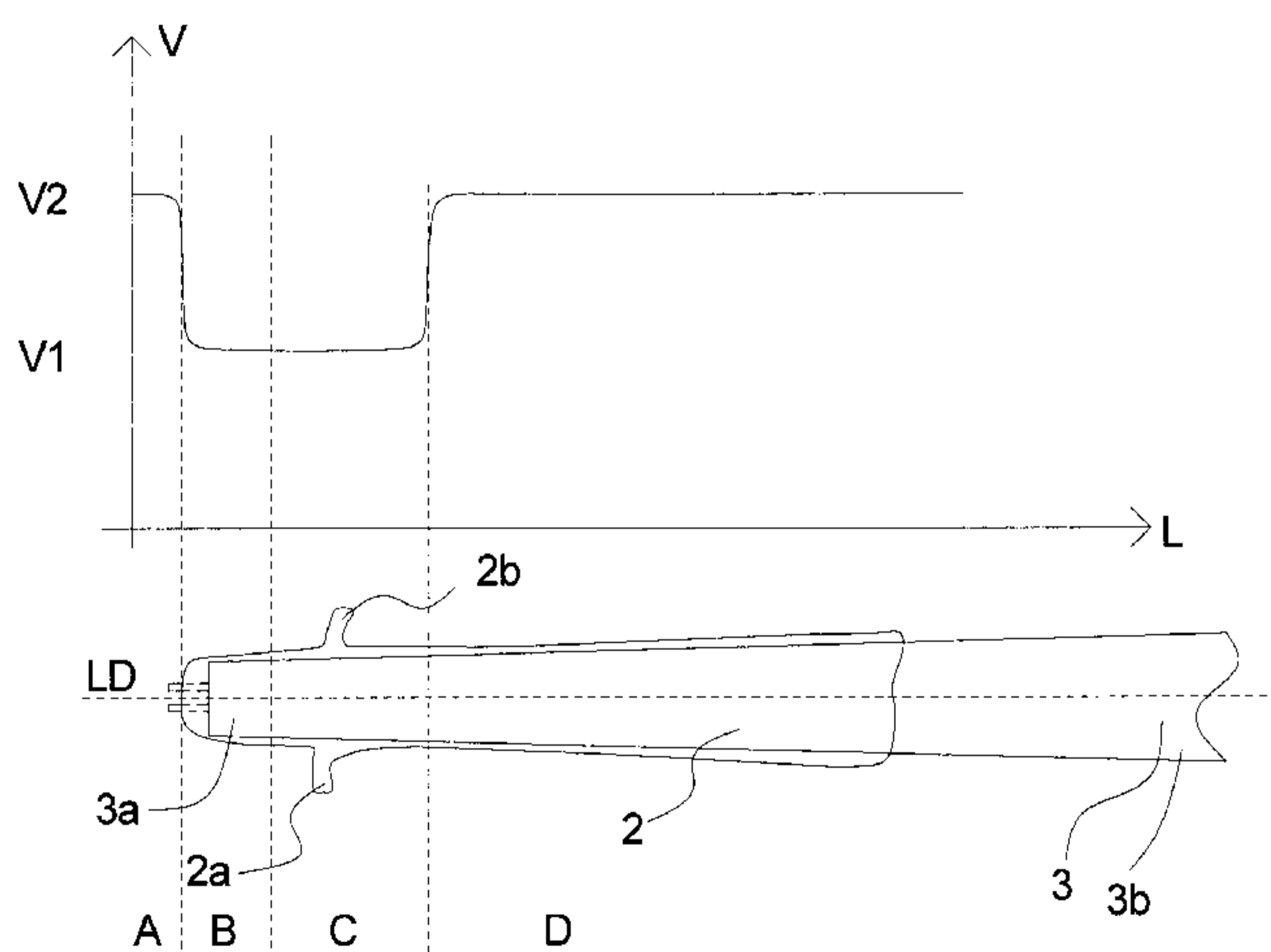

Fig. 6

(57) Abstract: The invention relates to an apparatus (1) for processing the skin side of a tubular fur (2), which apparatus comprises a tapering mandrel (3) with a first part (3a) that is thinner than a second part (3b) of the mandrel, on which mandrel (3) the tubular fur (2) can be drawn from the first part of the mandrel (3 a) towards the second part of the mandrel (3b) so that the skin side of the fur (2) faces outwards and the fur side of the fur faces inwards towards the mandrel (3), and at least a first scraper unit (4), comprising at least one scraper roller (4a) which, during operation and in contact with the skin side, is arranged to rotate so that scraping elements (6) on the scraper roller (4a) scrape the skin side of the fur (2). The mandrel (3) is arranged to be driven at different predefined speeds, comprising at least a first predefined speed (V1) and a second predefined speed (V2), where the first predefined speed (V1) is lower than the second predefined speed (V2), and where the apparatus is arranged to switch between the first predefined speed (V1) and the second predefined speed (V2) when the fur (2) on the mandrel (3) is in different predefined positions.

APPARATUS FOR PROCESSING FUR

The present invention relates to an apparatus for processing the skin side of a tubular fur by scraping the skin side by means of rotating scraping elements.

5

Background

A skin taken from a furred animal such as a fur normally has a layer or residues of fat, tendons and/or flesh that is firmly attached to the skin side of the fur. Before the fur can be used for further processing, such layers or residues must be removed from the skin side.

10

A prior art apparatus for processing such furs to remove layers or residues of fat, tendons and/or flesh on the skin side is described in Danish patent specification DK156669. This apparatus comprises a single scraper roller with V-shaped scraping elements to scrape the skin on each side of a mandrel, on which a tubular fur is arranged with the skin side facing outwards.

15

Danish patent specification DK173611 describes an apparatus for processing fur on a mandrel. The apparatus comprises several scraper rollers that, while scraping the skin side of the fur, cause the fur to rotate about its longitudinal axis.

20

European patent specification EP2093299 concerns an apparatus for processing fur in which the apparatus comprises two scraper rollers driven in opposite directions of rotation to achieve both a friction force against a thick end of a mandrel on which a fur is arranged and a friction force against the thin end of the mandrel.

25

The above apparatuses have various disadvantages that the present invention resolves.

The invention

The invention concerns an apparatus for processing the skin side of a tubular fur according to claim 1.

5 In a configuration, the invention concerns an apparatus for processing the skin side of a tubular fur, which apparatus comprises:

a tapering mandrel with a first part that is thinner than a second part of the mandrel, on which mandrel the tubular fur can be drawn from the first part of the mandrel
10 towards the second part of the mandrel so that the skin side of the fur faces outwards and the fur side of the fur faces inwards towards the mandrel,

at least a first scraper unit, comprising at least one scraper roller, which, during operation and in contact with the skin side, is arranged to rotate so that scraper
15 elements on the scraper roller scrape the skin side of the fur,

where the mandrel is arranged to be driven at different predefined speeds, comprising at least a first predefined speed and a second predefined speed,

20 where the first predefined speed is lower than the second predefined speed and

where the apparatus is arranged to switch between the first predefined speed and the second predefined speed when the fur on the mandrel is in different predefined positions.

25

Experience shows that in particular the area around the front legs of a fur, such as a mink fur, can often be difficult to process to remove, for example, flesh residues, fat, tendons and other material from the skin side of the fur. This is because areas, in particular under and behind skin parts of the fur that have covered the front legs of
30 the animal may, when the fur is being scraped, cover an area on the skin side that is thus not processed adequately. By using and switching between several predefined

speeds, it is possible to obtain a satisfactory processing of the fur in the mentioned areas by advancing the mandrel and the fur on it with a lower speed and provide an overall increase the speed of the processing of the fur without compromising on the quality of the fur when it is scraped.

5

In an embodiment of the apparatus in the above configuration, the switch is arranged to take place on the basis of the location of the fur in relation to a scraper roller.

By determining the location of the fur, it is possible to scrape different areas of the fur, where the mandrel is driven at different speeds. This makes it possible to achieve more advantageous, individual scraping of the fur. For example, areas on the fur that comprise skin parts that have covered the furred animal's legs may be processed while the mandrel is driven at the first speed, while the rest of the fur may be processed while the mandrel is driven at the second speed.

10
15

In general it is to be understood that the location of the fur in relation to a scraper roller may be determined by detecting the fur via a sensor, by detecting the location of the mandrel in relation to scraper rollers or another point on the apparatus or similar. An example might be to count the number of chain links during operation, if the mandrel is driven by a chain drive, to determine the location of the fur.

In an embodiment of the apparatus in the above configuration, the mandrel is arranged to be driven at the first speed in and/or around areas on the fur that are, or may be, covered by skin parts that have covered the furred animal's legs.

20
25

These areas have been shown to possibly require special processing to achieve adequate scraping of the fur in these areas.

In an embodiment of the apparatus in the above configuration, the mandrel is arranged to be driven at the second predefined speed after areas on the fur that are, or

30

may be, covered by skin parts that have covered the furred animal's legs have been processed by the scraper roller.

This allows faster processing of the fur to be achieved.

5

In an embodiment of the apparatus in the above configuration, the mandrel is arranged to be driven at the second speed until or just before the scraper roller comes into contact with the fur on the mandrel.

10 Faster processing of the fur is thus achieved as the fur, after it has been arranged on the mandrel, needs to come into contact with the scraper rollers to be processed.

It is furthermore preferred that the mandrel is arranged to be driven with the second predefined speed towards areas on the fur which are or may be covered by skin parts
15 that have covered the furred animal's legs. Hereby, the lower, first predefined speed of the mandrel is applied only in the areas where the more thorough scraping obtained by the lower mandrel speed is most required, i.e. the areas which are or may be covered by skin parts that have covered the furred animal's legs which provides for a fast processing of the individual fur.

20

In yet a preferred embodiment of the present invention, the mandrel is arranged to be driven with the said first predefined speed until areas on the fur which are or may be covered by skin parts that have covered the furred animal's legs has been processed by said at least one scraper roller whereupon the mandrel is driven with said second
25 predefined speed.

The first predefined speed is preferably no higher than 0.35 m/s, for example no higher than 0.32 m/s, such as no higher than 0.30 m/s.

30 Examples of the second, higher predefined speed might be >0.35 m/s, for example >0.37 m/s, such as >0.40 m/s.

It has been shown that this speed is particularly advantageous for processing mink fur in particular, as fast, thorough scraping of the fur is achieved.

- 5 The apparatus may further comprise a second scraper unit comprising at least one scraper roller, the first and second scraper unit being arranged on opposite sides of the mandrel. This makes it possible to scrape a large part of the fur in one procedure and provides for a counter pressure towards the mandrel from the second scraper unit in a direction opposite the pressure from the first scraper unit towards the mandrel.

10

The scraper units may each comprise at least one further scraper roller where the first scraper rollers and the second scraper rollers of the scraper units are arranged behind each other in the longitudinal direction of the mandrel so as to improve the scraping of the skin side of the fur on the mandrel.

15

- By using scraper units with at least two scraper rollers (note that a scraper unit may also comprise more than two scraper rollers) that rotate in the same direction of rotation, and in particular where at least one of the scraper rollers has V-shaped scraper elements, tests have shown that it is possible to achieve adequate processing of the fur in the more difficult areas, in particular under and behind skin parts of the fur that have covered the front legs of the animal. The first scraper roller in a set of scraper rollers thus processes the fur before the second roller in the same set processes the same area of the fur. In this way, the second scraper roller is able to remove fat residues, tendons, flesh residues, etc. that have not been removed by the first scraper roller. It is thus possible to regard the processing performed by the first scraper roller as rough scraping of the skin side, while the processing performed by the second scraper roller can be regarded as fine scraping or supplementary scraping.

20

25

- It has shown to be advantageous that said scraper rollers of said scraper units are arranged to act on the skin side with a friction force in the direction towards the second part of the mandrel.

30

It is furthermore preferred that at least one of the scraper rollers of each scraper unit comprises one or more substantially V-shaped scraper elements.

The V shape of the scraper rollers' scraper elements has several advantages. Firstly, the scraper elements prevent the fur from rotating on the mandrel. Among other things, this results in increased control over the scraping of the fur. The V shape also means that the fur on the mandrel can be stretched towards or away from a plane that passes through the centre axis of the mandrel in the longitudinal direction of the mandrel so that areas around edges or curves on the mandrel are processed, depending on how the scraper rollers are turned. The scraper rollers with the V-shaped scraper elements are arranged preferably so that the points of contact between the scraper rollers and the fur for each of the scraper elements' scraping edges, during operation, stretch the fur towards a plane that passes through the centre axis of the mandrel in the longitudinal direction of the mandrel. Thus, e.g. the parts of the skin arranged on edges of the mandrel (for example in embodiments where the mandrel comprises substantially plane surfaces, e.g. a square formed tapering mandrel with four edges extending in the longitudinal direction of the mandrel) the skin parts at or near the edges are adequately scraped.

In an embodiment, one or more of the rollers in a scraper unit can be arranged so that the points of contact between the scraper rollers and the fur for each of the scraper elements' scraping edges move away from a plane that passes through the centre axis of the mandrel in the longitudinal direction of the mandrel. In this way, the fur is stretched away from the plane.

Note in general that the scraper rollers in a scraper unit, which comprises several scraper rollers, can be arranged in parallel (which is preferred in several cases), but they can also be arranged at an angle to each other.

A scraper unit with several scraper rollers may also comprise scraper rollers with another (other) characteristic(s) than V-shaped scraper elements, for example

essentially parallel, inclined scraper elements, several scraper elements arranged in a V shape with spaces between the end parts of the scraper elements, and/or similar.

In a preferred embodiment of the invention, at least two scraper rollers in a scraper
5 unit have different characteristics.

The term 'different characteristics' means that the scraper rollers in a set of scraper rollers may, for example, have a different design and/or size, a different number of scraper elements, a different angle of the scraper elements on the scraper rollers, a
10 different design of the scraper elements on the rollers, a different arrangement of the scraper rollers, etc. This may have the advantage that it is possible to achieve different types of processing of the skin side of the fur in the same working process.

In one embodiment of the invention, the different characteristics comprise at least
15 that one scraper unit comprises two scraper rollers with opposing, essentially V-shaped scraper elements.

In this way, one of the two scraper rollers can stretch the fur away from a plane that passes through the centre axis of the mandrel in the longitudinal direction of the
20 mandrel, while the other of the two scraper rollers stretches the fur towards the same plane that passes through the centre axis of the mandrel in the longitudinal direction of the mandrel. This may have certain advantages as the opposing scraper elements cause force impacts on the fur in different directions in the same procedure.

25 In one embodiment of the invention, the different characteristics comprise at least that one scraper roller in a scraper unit, during operation, is arranged to rotate at a speed that is higher than another scraper roller in the same scraper unit.

Different roller speeds may cause different peripheral speeds of the scraper rollers in
30 a scraper unit. As the fur can, in this way, be scraped with scraper rollers at different speeds, this may have a positive effect on the quality of the processing of the fur. A

non-limiting example may be that the first scraper roller in a scraper unit is driven at a speed of between 1200 and 1600 RPM, and a second scraper roller in the scraper unit can be driven at a rotational speed of between 2000 RPM and 2500 RPM.

5 It is also possible, by rotating the rollers at different speeds, to achieve a situation in which different sizes of scraper rollers are able to cause essentially the same effect on the skin side, for example by adjusting the speed of the scraper rollers so that the peripheral speed is the same, by the speed being adapted so that the skin side experiences essentially the same number of scraping actions from the scraper
10 elements on both scraper rollers when the fur passes the rollers. This makes it possible to achieve easier implementation of several scraper rollers in one apparatus with limited space available.

In one embodiment of the invention, the different characteristics comprise at least
15 that one scraper roller in a scraper unit has a diameter that is larger than the diameter of another scraper roller in the same scraper unit.

This may have certain advantages as this makes it possible easily to achieve different peripheral speeds for the scraper rollers. It is also possible to achieve a space-saving
20 solution.

In a preferred embodiment of the invention, the scraper rollers in a scraper unit, during operation, are arranged to rotate around an essentially vertical axis to scrape the skin side arranged on side parts of the mandrel.
25

Note, of course, that one or more scraper rollers in embodiments may be arranged to rotate around an essentially horizontal axis to scrape fur parts/sections arranged on the top and/or bottom of the mandrel.

30 The apparatus is preferably also provided with two additional scraper units each comprising at least one scraper roller arranged so that the two additional scraper units

during operation of the apparatus will apply a force to the skin side from opposite sides of the mandrel in a direction towards the second part of the mandrel, where the additional scraper units are arranged to rotate around an essentially horizontal axis during operation of the apparatus in order thus to scrape at least one part of the fur that is not or will not be processed by the first scraper unit or second scraper unit.

By scraping the entire skin side of the fur in the same procedure, it is possible to achieve increased fur processing speed, in which connection several furs can be scraped. Examples of a machine with both scraper rollers that rotate around a vertical axis to scrape fur on side parts of the mandrel and scraper rollers that rotate around a horizontal axis to scrape fur on the top and bottom of the mandrel have made it possible to process more than 200 mink furs in an hour.

Note, however, that there may be an overlap between the processing by the first or second scraper roller unit and the additional scraper units. For example on account of extensions/stretching of the fur caused by the preferred V shape of the scraper rollers.

The scraper rollers of a scraper unit are in a preferred embodiment of the present invention arranged to be driven by the same drive means such as an electric motor.

It is advantageous to drive several scraper rollers using the same drive unit as this represents a cost efficient solution in relation to driving each roller with an individual drive unit. Note, of course, that each scraper roller in embodiments may also be driven individually by a separate drive unit, and any suitable arrangement of scraper rollers and drive units in different embodiments of the invention may be used.

In a preferred embodiment of the invention, the scraper rollers in a scraper unit are arranged to be driven by means of the same belt drive or chain drive.

As the scraper rollers in a scraper unit rotate in the same direction towards the thicker end of the mandrel, it is possible to drive the scraper rollers via a belt drive or a chain drive, which is a cost efficient, reliable way in which to drive rotating parts. For example to drive several scraper rollers with the same drive unit. Alternatively, the scraper rollers in a scraper unit could be driven by means of, for example, an arrangement of gearwheels.

The one or more scraper units are preferably arranged to be movable towards and away from the mandrel and to comprise a pressure device designed to apply to said at least one scraper roller a contact pressure against the skin side, where the apparatus comprises a damper arrangement for damping the movement of the at least one scraper unit towards and/or away from the mandrel.

The apparatus may advantageously be arranged with one or more actuators or other pressure arrangements that can control and apply the scraper rollers' contact pressure to the fur on the mandrel. When one scraper roller on the apparatus reaches an area on the fur with a projection (for example an area covered by/comprising skin parts that have covered the furred animal's legs), there is a risk that the scraper roller will unintentionally reduce the contact pressure on the fur on a piece of the fur during and/or after contact with the projection. The reason for this may be that actuators or other force-inducing means, which may be part of the pressure arrangement that applies the contact pressure and are often driven via pneumatics or hydraulics, are forced backwards by the projection for a moment, for example in connection with increased compression of the liquid or air in the actuator. The consequences of this may be that the skin is not scraped adequately by the scraper roller and there may therefore be flesh, fat and/or tendon residues that are not removed from the skin in these areas around the skin parts. By implementing a damper arrangement on the apparatus in a suitable location, it is possible to reduce or completely avoid unintentional reduction of the contact pressure and thus achieve better processing of areas around the skin parts which has covered the legs of the animal. It is/may also

be possible to prevent the scraper rollers from skipping an area that is after these parts of the skin.

Note also that a damper device in accordance with the invention may advantageously
5 be implemented in an apparatus such as that specified in European patent specification EP2093299.

In one embodiment of the apparatus in the above damper configuration, at least one scraper roller, during operation and in contact with the skin side, is arranged to act on
10 the skin side with a friction force in a direction towards the second part of the mandrel.

This achieves advantageous scraping of the fur and, as the friction force from the scraping is directed towards the second part of the mandrel, i.e. the thicker part, the
15 fur will remain on the mandrel without additional fixing of the fur on the mandrel being necessary.

In a preferred embodiment of the apparatus in the above damper configuration, the damper arrangement comprises one or more linear shock absorbers.

20

A linear shock absorber preferably comprises a cylinder and a piston arranged inside the cylinder, whereby the shock absorption is achieved by the piston compressing a fluid such as a liquid or gas inside the cylinder, which thus absorbs energy from the shock. Alternatively, the damper arrangement could comprise other suitable shock-
25 absorbing means such as a shock-absorbing, compressible material, for example a rubber material with a suitable hardness that can have a shock-absorbing effect. Linear shock absorbers have proved to be useful for damping the scraper unit's movement towards and/or away from the mandrel. It is naturally understood that any suitable shock absorbing means may be utilized in aspects of the invention.

30

In a preferred embodiment, the damper arrangement comprises one or more shock-absorbing means arranged to absorb shock impacts in the horizontal plane towards and/or away from the mandrel.

5 Skin parts that have covered the furred animal's legs are often arranged on the side parts of the mandrel, and these areas are processed by scraper rollers with a rotational axis that is essentially vertical and is arranged to scrape the fur arranged on the mandrel's side parts by applying an essentially horizontal contact pressure. If
10 projections on the fur can apply a force that opposes the horizontal scraper pressure, it may be particularly advantageous to absorb shock impacts in the horizontal plane.

It is preferred that the damper arrangement or arrangements damp movements towards and/or away from the mandrel on any additional scraper units for scraping the skin side which might be on the apparatus/mandrel, including for example
15 scraper units arranged to scrape the skin side arranged on the upper and/or lower part of the mandrel. Thus, the apparatus may, in embodiments, comprise a suitable number of shock-absorbing means and/or damper devices/arrangements arranged to damp shock impacts on both scraper rollers arranged to scrape skin parts on a fur arranged on the side of the mandrel and/or on the upper and/or lower part of the
20 mandrel.

The invention furthermore concerns a computer program product designed for installation to control an apparatus in accordance with one or more embodiments described in his document, where the computer program product is adapted to drive
25 the mandrel at the different predefined speeds when the computer program product is installed to control the apparatus.

Such a computer program product may, for example, be advantageous in connection with improvements to existing apparatuses as the program may, for example, be
30 installed as a software update to make it possible to use different mandrel drive

speeds as described in the document. Note, of course, that the computer program product in the embodiments may be installed in new machines.

Figures

The following contains non-limiting examples of embodiments of the invention described and explained in detail with reference to the figures, where:

- 5 Figure 1: shows a diagram of a preferred embodiment of part of an apparatus in accordance with the invention, with scraper units with several scraper rollers seen from above,
- Figure 2: shows a preferred embodiment of a scraper roller used in the apparatus,
10 seen in perspective,
- Figure 3: shows a preferred embodiment of part of an apparatus in accordance with the invention, seen in perspective, with both horizontal and vertical scraper rollers,
15
- Figure 4: shows a preferred embodiment of part of an apparatus in accordance with the invention, seen in perspective, where the apparatus comprises various scraper units with several scraper rollers,
- 20 Figure 5: shows an embodiment of the invention where the apparatus comprises a damper device,
- Figure 6: shows an embodiment of the invention where the apparatus can drive a mandrel at one or more predefined speeds, and where
25
- Figure 7: shows an example of an area on a fur that the apparatus in accordance with the invention is particularly designed also to scrape adequately.

Detailed description

- 30 Figure 1 shows an advantageous embodiment of an apparatus 1 in accordance with the invention for processing the skin side of a tubular fur 2, preferably a mink fur.

The tubular fur 2 comprises a fur side and a skin side. The fur comprises different skin parts that originally, before the fur was removed from the furred animal, enclosed different parts of the body of the furred animal. For example skin parts 2a, 5 2b that enclosed the legs of the furred animal.

The fur is placed on a mandrel 3 with a first part 3a that is thinner than a second part 3b of the mandrel 3. The mandrel thus creates/forms a mandrel 3 with a tapered end, where the fur 2 can be drawn on the mandrel from the thin part 3a of the mandrel 3. 10

The apparatus also comprises one, two or more scraper units 4, 5, preferably at least two scraper units 4, 5. Each scraper unit 4, 5 comprises, as shown, at least two scraping means in the form of scraper rollers 4a, 4b, 5a, 5b designed to rotate to apply a force F_1 to the skin side of the fur from opposite sides of the mandrel 3 in a 15 direction towards the second part 3b of the mandrel, i.e. the thicker part of the mandrel. The first scraper unit 4 thus comprises a first scraper roller 4a and a second scraper roller 4b, and the second scraper unit 5 comprises a first scraper roller 5a and a second scraper roller 5b.

20 The scraper rollers in a scraper unit 4, 5 are, as indicated with arrows, arranged to rotate in the same direction of rotation. This means that the scraper rollers 4a, 4b in the first scraper unit 4 are arranged to rotate in the same direction of rotation and the scraper rollers 5a, 5b in the second scraper unit 5 are arranged to rotate in the same direction of rotation.

25 As shown, the scraper rollers 4a, 4b rotate in the same direction of rotation during operation but in a direction of rotation that is the opposite direction of rotation to that of the scraper rollers 5a, 5b. As can be seen, the scraper rollers 4a, 4b, 5a, 5b rotate around centre axes (not shown) of the scraper rollers that are essentially parallel. In 30 other embodiments, the scraper rollers in a scraper unit 4, 5 could be arranged at an angle to each other (not shown).

The mandrel 3 and the scraper units 4, 5 are arranged to be moved in relation to each other in the longitudinal direction LD of the mandrel. This is preferably achieved by the mandrel 3 being moved towards the tapered end of the mandrel 3, while the
5 scraper units 4, 5 are not moved in the longitudinal direction of the mandrel.

Alternatively, the mandrel could be fixed and the scraper units could thus be moved along the mandrel 3. Equally, both the mandrel 3 and the scraper units 4a, 4b could be moved in relation to each other.

10 In embodiments in which the mandrel 3 is moved in a direction towards the tapered end of the mandrel 3, the scraper rollers 4a, 4b, 5a, 5b will apply a force against the direction of motion of the mandrel, against the thicker, second part of the mandrel
3b.

15 The scraper units 4, 5 are arranged to be movable towards and away from the mandrel 3 in order to be able to apply a controlled contract pressure against the skin side of the fur on the mandrel. This may, for example, be controlled via one or more pressure arrangements 12, comprising, for example, linear actuators such as
20 pneumatic cylinders, a spindle or other device, preferably as described in further details below.

Each of the scraper rollers and/or each scraper unit may be mounted to oscillate around an axis of oscillation (not shown) in relation to the frame 10 of the apparatus
1.

25 As indicated in Figure 1, scraper rollers are driven in a scraper unit, preferably via the same belt drive or chain drive 13, as the scraper rollers in a scraper unit 4, 5 are driven in the same direction of rotation, as shown with arrows. Alternatively, it would be possible to use a gearwheel arrangement.

30

Figure 2 shows an example of a preferred scraper roller, called 4a in Figure 2, but it could be any scraper roller in a scraper arrangement in apparatus 1. The scraper roller 4a comprises end surfaces 11a between which there is a continuous peripheral surface 11b. The peripheral surface 11b has a number of scraper elements 6 mounted at peripheral distances from each other that determine or are located on a generally circular, cylindrical surface. Each scraper element 6 is generally V-shaped. The scraper element preferably forms an obtuse angle Φ , but it can also form an acute angle. The V-shaped scraper elements' top points are located in a plane of symmetry that is substantially perpendicular to the roller's axis. Seen in cross-section, the roller has an outline that is reminiscent of a circular saw blade. The scraper roller also has an axial drilled hole 11c for receiving a drive shaft.

The scraper roller 4a, which is preferably made of rubber, plastic material or a similar elastic, ductile material, is preferably caused to rotate in the direction of rotation indicated with an arrow in Figure 2. This means that the fur that is processed will first be brought into contact with free outer ends of each of the scraper elements 6 and, during the continued rotation of the scraper roller, the two points of contact of each of the scraping edges will move in a direction towards the scraper roller's central plane of symmetry where the tip of the V shape is formed. As a consequence of this, the roller will have a tendency to pull the fur on the mandrel in a direction towards this central plane. This situation will, in this connection, cause the residues of fat, flesh and/or tendons also to be removed from the parts of the fur located along the edges of the mandrel 3.

Likewise, a scraper roller could also be imagined with scraper elements 6 with a V shape that causes the roller, during its continued rotation, to move the two points of contact of each of the scraper elements 6 in a direction away from the roller's central plane of symmetry towards free outer ends of each of the scraper elements 6. As a consequence of this, the scraper roller will have a tendency to pull the fur in a direction away from the roller's plane of symmetry.

Note in general that the scraper rollers in a scraper unit 4, 5, as indicated, for example, in Figure 1, may have different diameters. In non-limiting examples, it could be imagined that the diameter of the first scraper roller 4a, 5a has a diameter that is over twice the diameter of the second scraper roller 4b, 5b. For example, the first scraper roller 4a, 5a could have a diameter of between 100 and 150 mm, while the second scraper roller could have a diameter of between 40 and 70 mm. In a specific test with a test setup of the apparatus 1, tests were carried out with scraper units 4, 5, comprising a first scraper roller 4a, 5a with a diameter of approximately 132 mm and a second scraper roller 4b, 5b with a diameter of approximately 65 mm, with satisfactory results.

Figure 3 shows an embodiment of the apparatus 1, comprising both scraper rollers 8a, 9a arranged horizontally and scraper rollers 4a, 4b, 5a, 5b arranged vertically. Each scraper unit 4, 5, 8, 9 comprises, in this embodiment, at least one drive unit 7, to drive the scraper rollers 4a, 4b, 5a, 5b, 8a, 9a. The scraper units 8, 9 with the horizontally arranged scraper rollers 8a, 9a are arranged to apply a force to the skin side from opposite sides of the mandrel 3, i.e. in this case the top and bottom surfaces of the mandrel, in a direction towards the second part 3b of the mandrel. The scraper units 4, 5 with the vertically arranged scraper rollers 4a, 4b, 5a, 5b are also arranged to apply a force to the skin side from opposite sides of the mandrel 3, in this case the side parts of the mandrel 3, in a direction towards the second part 3b of the mandrel 3.

The scraper units 8, 9 with the horizontal scraper rollers are preferably displaced in relation to the scraper units 4, 5 with the vertical scraper rollers, along the longitudinal direction LD of the mandrel. This, together with the V shape of the scraper elements, causes the residues of fat, flesh and/or tendons also to be removed from the parts of the fur 2 located along the edges of the mandrel 3.

As indicated in Figure 3, the scraper rollers 4a, 4b, 5a, 5b in a scraper unit 4, 5 with several scraper rollers may be driven by the same drive unit 7, which is preferably an

electric motor. Alternatively, each scraper roller in a scraper unit 4, 5, 8, 9 could be driven by an individual drive unit 7.

In the examples indicated in, for example, Figures 1 and 3, the scraper rollers 4a, 4b, 5a, 5b in a scraper arrangement are driven by the same drive unit 7 via a belt drive or a chain drive. The belt drive, chain drive or gearwheel arrangement is preferably arranged inside a casing 14 for reasons of hygiene and safety.

Figure 4 shows an embodiment of the invention in which both the scraper units 4, 5 arranged on opposite sides of the mandrel to scrape the skin side on the side parts of the mandrel 3 and the scraper units 8, 9 arranged on opposite sides of the mandrel to scrape the skin side on the upper and lower parts of the mandrel 3 all comprise two scraper rollers 4a, 4b, 5a, 5b, 8a, 8b, 9a, 9b. All scraper rollers are arranged to rotate to act on the skin side with a friction force in a direction towards the second part 3b of the mandrel 3.

Figure 5 shows an additional advantageous embodiment of the apparatus in accordance with the present invention, seen from above. As indicated in Figure 5, the apparatus comprises a guide arrangement arranged to guide each scraper unit 4, 5 during its movement to apply a contact pressure on the skin side on the mandrel 3. The guide arrangement comprises, in this embodiment, two guide elements 15 in the form of parallel, fixed rods that are arranged essentially perpendicular to the longitudinal direction of the mandrel 3. A scraper unit is thus connected to these parallel rods and may be guided and displaced in relation to the rods 15 in the longitudinal direction of the rods. Alternatively, the guide elements could comprise other elements in the form of, for example, a hinge (not shown) connected to both the frame of the apparatus 1 and a scraper unit, around which the scraper unit can rotate. Other suitable ways of guiding the scraper units could also be relevant for use in the present invention.

The contact pressure F_1 of a scraper unit is controlled and regulated preferably via one or more pressure arrangements 12, preferably in the form of one or more linear actuators. This/these pressure arrangements 12 may, on activation, cause the scraper roller/scraper rollers 4a, 4b, 5a, 5b in a scraper unit to be pressed against the fur on the mandrel 3. Figure 5 shows two scraper units 4, 5 that can be pressed against the mandrel, each via its pressure arrangement.

As indicated, one scraper unit 4, 5 in, for example, this embodiment may thus comprise only one scraper roller 4a, 5a (not shown in any figures), two scraper rollers 4a, 4b, 5a, 5b as shown in one or more of the Figures 1, 3, 4 and 5 and specified in the associated description or even more scraper rollers.

The pressure may preferably be adjusted on the basis of the characteristics of the fur. For example, it has been shown to be advantageous to vary the contact pressure on the basis of the gender of the animal from which a mink fur, in particular, has been taken. The contact pressure could also be varied actively during the processing of a fur.

As shown in Figure 5, the apparatus also comprises one or more damper arrangements 16 to damp a scraper unit's 4, 5 movement towards and/or away from the mandrel 3, for example caused by projections on the fur on the mandrel (such as projections comprising skin parts that have covered the furred animal's legs), caused by the mandrel 3 unintentionally making a sideways movement perpendicular to its longitudinal direction LD or similar. The damper device(s) can thus absorb forces F_2 towards and/or away from the mandrel 3.

The damper arrangement(s) 16 comprise(s) preferably one or more linear shock absorbers as shown, comprising a cylinder and a piston that can be displaced inside the cylinder in the longitudinal direction of the cylinder. The damper arrangement(s) 16 preferably absorb(s) shock impacts in the horizontal plane towards and/or away from the mandrel 3.

The damper arrangement(s) is/are preferably designed and arranged in such a way that it/they reduce(s) the compression of the pressure arrangements(s) 12 and reduce the oscillations of the scraper unit(s).

5

The damper arrangement may thus comprise one or more shock-absorbing means arranged to damp horizontal and/or vertical oscillations/shocks. The damper device may also comprise one or more shock-absorbing means that damp shock impacts in other directions perpendicular to (and/or with components perpendicular to) the longitudinal direction of the mandrel 3.

10

It is thus noted that, for example, an apparatus comprising scraper units 8, 9, preferably arranged on opposite sides of the mandrel to scrape the skin side of the upper and lower parts of the mandrel, for example as shown in Figures 3 and 4 in embodiments, may also comprise shock-absorbing means to counteract the movement of the scraper roller(s) 8a, 8b, 9a, 9b and/or scraper units 8, 9 towards and away from the mandrel when they are arranged to be in contact with the mandrel. The apparatus may, therefore, in different embodiments, comprise damper devices 16 designed to absorb shock impacts towards and away from the mandrel 3 on scraper units 4, 5, 8, 9 and/or their scraper rollers 4a, 4b, 5a, 5b, 8a, 8b, 9a, 9b.

15

20

The damper arrangement 16 may comprise passive, shock-absorbing elements and the damper device may comprise active shock-absorbing means controlled by a control unit (not shown) in the apparatus 1. Such active shock-absorbing means could, in one embodiment, be implemented via PD (Proportional-Derivative) regulation, PID (Proportional-Integral-Derivative) regulation or similar.

25

In an additional advantageous embodiment, the mandrel 3, may be moved in the longitudinal direction LD of the mandrel in a direction towards the first part 3a of the mandrel at a first predefined speed V1 that is no higher than 0.35 [m/s], for example no higher than 0.32 [m/s], such as no higher than 0.30 [m/s].

30

As shown in Figure 6, the apparatus may also be designed to drive the mandrel at a second predefined speed V2, where the first predefined speed V1 is lower than the second predefined speed V2. The apparatus is thus designed to switch (preferably automatically) between the first predefined speed V1 and the second predefined speed V2 when the fur 2 on the mandrel 3 is in different predefined positions/areas. In the embodiment of the invention shown in Figure 6, the apparatus 1 is arranged to drive the mandrel 3 at the first speed V1 essentially from the front end of the fur 2 until the scraper roller(s) in a scraper unit has(have) processed and passed areas C with and around skin parts of fur 2 that have enclosed the furred animal's legs. The speed then switches automatically to the second, higher speed V2 as indicated in area D.

In an additional embodiment, the mandrel 3 may be driven at the second speed V2 (or a third speed) until or just before a scraper roller in a scraper unit comes into contact with the fur on the mandrel (area A).

The mandrel 3 may also, in one embodiment, be driven at the first speed V1 or a second predefined speed until the scraper rollers have proper contact with the fur in area B before area C with and around skin parts 2a, 2b. This may be relevant as it has been shown that, in some cases, the speed of the mandrel may affect how well the scraper elements can get under tendons and fat, in particular, at the front end of the fur 2 when the scraper elements come into contact with the fur.

Note in general that the apparatus 1 preferably comprises a control unit (not shown in any figure) to control the contact pressure of the scraper rollers on the mandrel, propulsion of the mandrel, rotation of scraper rollers and possibly further processing of the fur, etc. This further processing may, for example, comprise the apparatus 1 applying sawdust to the skin side of the fur after it has been scraped, the fur automatically being turned off the mandrel after the scraping and/or similar.

Thus, it is to be understood that the control unit may, for example, comprise a control system comprising suitable means such as data memory, data processors, inputs from sensors to receive data from, for example, measurements such as the position and/or speed of the mandrel and outputs for control systems to control the speed and/or
5 similar of the mandrel that enable the apparatus to control the speed of propulsion of the mandrel 3 at different speeds.

A computer program product designed for installation to control the apparatus 1 could thus allow the mandrel 3 to be driven at different predefined speeds such as V1
10 and V2 stated above. This computer program product may thus, for example, be installed in a new apparatus 1 or possibly be installed in an existing apparatus 1 as a software update to achieve propulsion of the mandrel 3 at different speeds.

A non-limiting example could be that the computer program product comprises a
15 PLC (Programmable Logical Computer) program and that the apparatus 1 thus comprises a PLC installed in a suitable manner to perform instructions specified in the program. Note, of course, that the apparatus may comprise any conceivable suitable computer-based control system which, when the computer program product is installed in the control system, is able to control the apparatus according to the
20 instructions in the computer program to control the mandrel at the different speeds.

Figure 7 shows an example of an area AR1 on a fur that the apparatus is particularly designed also to scrape adequately via one or more of the above embodiments, comprising several scraper rollers 4a, 4b, 5a, 5b, 8a, 8b, 9a, 9b in a scraper unit 4, 5,
25 8, 9, via damper device(s) 16 and/or via one or more predefined speeds of the mandrel 3. The area in the figure shows a section of a fur, preferably a fur from a mink, with skin parts 2a, 2b that have enclosed a leg of the mink. Particularly behind and/or below and around this skin part 2a, 2b, there may be residues 17 of fat, tendons and/or flesh that are particularly difficult to remove but may be removed
30 advantageously with an apparatus 1 in accordance with the present invention.

Of course, it is clear that various changes and modifications may be made to the embodiments shown in the drawings without departing from the invention as described in this document. Non-limiting examples may, for example, be that a scraper unit comprises one, two, three, four or even more scraper rollers, that the
5 apparatus 1 may comprise the use of one scraper roller in a scraper unit with one or more damper arrangements and/or speed variations of the mandrel 3, that several scraper rollers are used in a scraper unit with one or more damper arrangements and/or speed variations of the mandrel 3, that a control system in the apparatus can adjust the rotational speed of the scraper rollers to one or more predefined speeds,
10 and/or similar.

List

- 1: Apparatus for processing the skin side of a tubular fur.
- 2: Tubular fur.
- 2a, 2b: Skin parts that have covered a furred animal's legs.
- 5 3: Mandrel with tapered end.
- 3a: First part of the mandrel that is thinner than a second part of the mandrel.
- 3b: Second part of the mandrel.
- 4, 5: Scraper arrangements, for example scraper arrangements arranged vertically.
- 10 4a, 4b: Scraper rollers in a first scraper element.
- 5a, 5b: Scraper rollers in a second scraper element.
- 6: Scraper elements on scraper rollers.
- 7: Drive unit to drive scraper rollers.
- 8, 9: Scraper elements with scraper rollers arranged horizontally.
- 15 8a, 8b,
9a, 9b: Scraper rollers arranged horizontally.
- 10: Frame of the apparatus.
- 11a: End surfaces of scraper rollers.
- 11b: Continuous surface of scraper roller.
- 20 11c: Axial drilled hole in a scraper roller to accept a drive shaft.
- 12: Pressure arrangement to apply contact pressure to the fur.
- 13: Belt drive or chain drive to drive scraper rollers in a scraper unit.
- 14: Case for belt drive or chain drive.
- 15: Guide elements on guide arrangement.
- 25 16: Damper arrangement.
- 17: Residues of fat, tendons and/or flesh below and/or behind skin part.

Claims

1. An apparatus (1) for processing the skin side of a tubular fur (2), which apparatus comprises:

5

a tapering mandrel (3) with a first part (3a) that is thinner than a second part (3b) of the mandrel, on which mandrel (3) the tubular fur (2) can be drawn from the first part of the mandrel (3a) towards the second part of the mandrel (3b) so that the skin side of the fur (2) faces outwards and the fur side of the fur faces inwards towards the
10 mandrel (3),

at least a first scraper unit (4), comprising at least one scraper roller (4a) which, during operation and in contact with the skin side, is arranged to rotate so that scraping elements (6) on the scraper roller (4a) scrape the skin side of the fur (2),

15

where the mandrel (3) is arranged to be driven at different predefined speeds, comprising at least a first predefined speed (V1) and a second predefined speed (V2),

where the first predefined speed (V1) is lower than the second predefined speed
20 (V2), and

where the apparatus is arranged to switch between the first predefined speed (V1) and the second predefined speed (V2) when the fur (2) on the mandrel (3) is in different predefined positions.

25

2. An apparatus according to claim 1, where the mandrel (3) is arranged to be driven at the first speed (V1) in and/or around areas on the fur (2) that are, or may be, covered by skin parts (2a, 2b) that have covered the furred animal's legs.

30

3. An apparatus according to claim 1 or 2, where said mandrel (3) is arranged to be driven with the second predefined speed (V2) after areas on the fur (2) that are, or

may be, covered by skin parts (2a, 2b) that have covered the furred animal's legs have been processed by the scraper roller (4a).

4. An apparatus according to one or more of claims 1, 2 or 3, where the mandrel (3) is arranged to be driven with the second predefined speed (V2) until or just before the scraper roller (4a) comes into contact with the fur (2) on the mandrel (3).

5. An apparatus according to one or more of claims 1-4, where the mandrel (3) is arranged to be driven with the second predefined speed (V2) towards areas on the fur (2) which are or may be covered by skin parts (2a, 2b) that have covered the furred animal's legs.

6. An apparatus according to any of the preceding claims, where the mandrel (3) is arranged to be driven with the said first predefined speed (V1) until areas on the fur (2) which are or may be covered by skin parts (2a, 2b) that have covered the furred animal's legs has been processed by said at least one scraper roller (4) whereupon the mandrel is driven with said second predefined speed (V2).

7. An apparatus according to any of the preceding claims, where said first predefined speed is not higher than 0.35 [m/s], e.g. no more than 0.32 [m/s], such as no more than 0.3 [m/s].

8. An apparatus according to any of the preceding claims, said apparatus further comprises a second scraper unit (5) comprising at least one scraper roller (5a), the first and second scraper unit (4, 5) being arranged on opposite sides of the mandrel (3).

9. An apparatus according to claim 8, where the scraper units (4,5) each comprises at least one further scraper roller (5a, 5b) where the first scraper rollers (4a, 4b) and the second scraper rollers (5a, 5b) of the scraper units (4, 5) are arranged behind each other in the longitudinal direction of the mandrel.

10. An apparatus according to claim 9, wherein said scraper rollers (4a, 4b, 5a, 5b) of said scraper units (4, 5) are arranged to act on the skin side with a friction force in the direction towards the second part (3b) of the mandrel (3).

5

11. An apparatus according to claim 9 or 10, where at least one of the scraper rollers (4a, 4b, 5a, 5b) of each scraper unit comprises one or more substantially V-shaped scraper elements (6).

10 12. An apparatus in accordance with one or more of the preceding claims, where the apparatus comprises two additional scraper units (8, 9) each comprising at least one scraper roller (8a, 8b, 9a, 9b) arranged, during operation, to apply a force to the skin side from opposite sides of the mandrel (3) in a direction towards the second part (3b) of the mandrel,

15

where the additional scraper units (8, 9), during operation, are arranged to rotate around an essentially horizontal axis in order thus to scrape at least one part of the fur (2) that is not or will not be processed by the first scraper unit (4) or second scraper unit (5).

20

13. An apparatus according to claim 9, 10, 11 or 12, where scraper rollers (4a, 4b, 5a, 5b, 8a, 8b, 9a, 9b) of a scraper unit (4, 5, 8, 9) are arranged to be driven by the same drive means (7) such as an electric motor.

25 14. An apparatus according to any of the preceding claims, where said at least one or more scraper units (4, 5) are arranged to be movable towards and away from the mandrel (3) and comprise a pressure device designed to apply to said at least one scraper roller (4a, 5a) a contact pressure against the skin side, and

30 where the apparatus comprises a damper arrangement for damping the movement of the at least one scraper unit (4, 5) towards and/or away from the mandrel (3).

15. An apparatus according to claim 14, where the damper arrangement comprises one or more linear shock absorbers.
- 5 16. A computer program product for installation to control an apparatus (1) in accordance with one or more of claims 1-7, where the computer program product is adapted to drive the mandrel (3) at the different predefined speeds (V1, V2) when the computer program product is installed to control the apparatus (1).

2/7

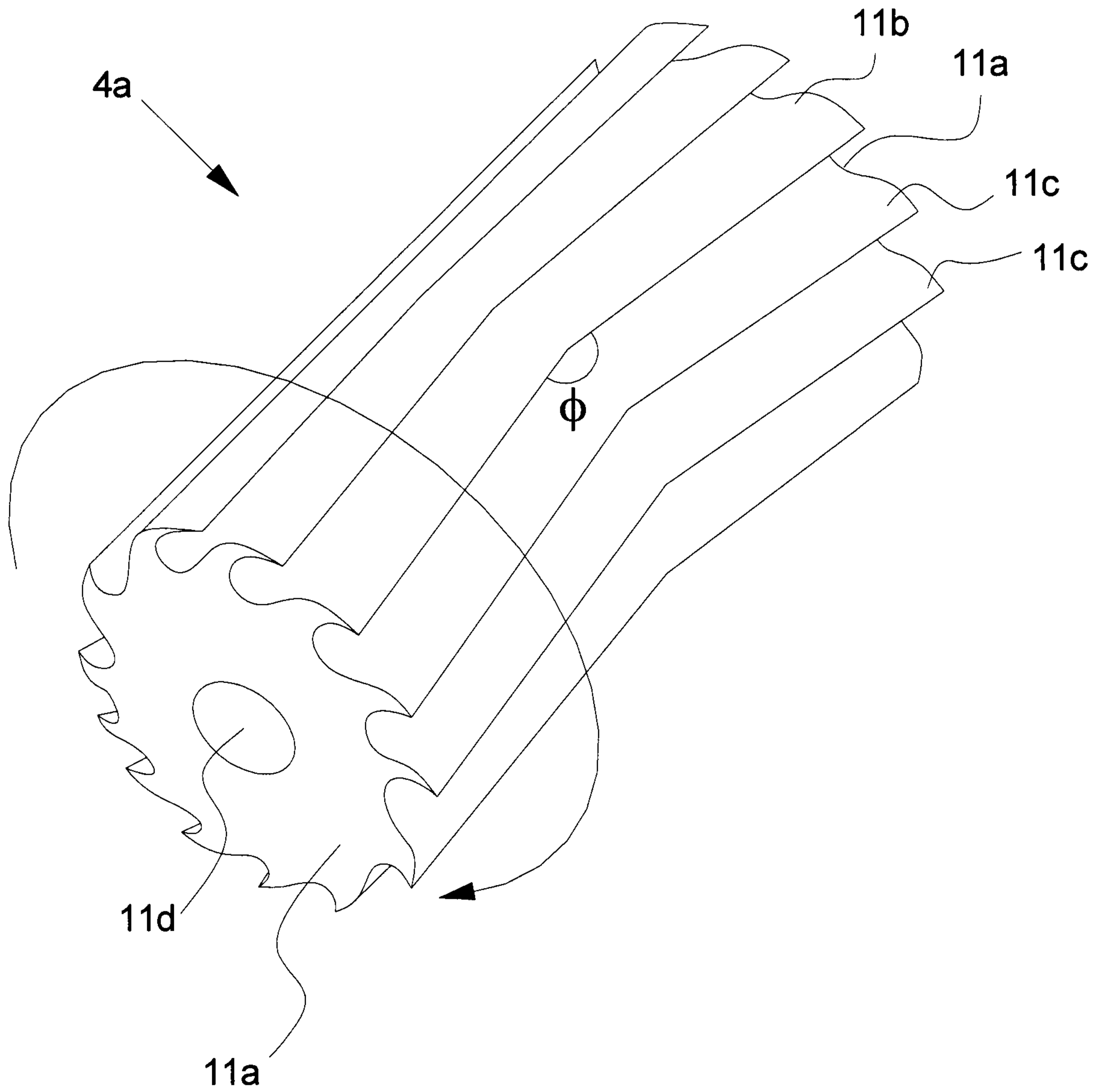

Fig. 2

3/7

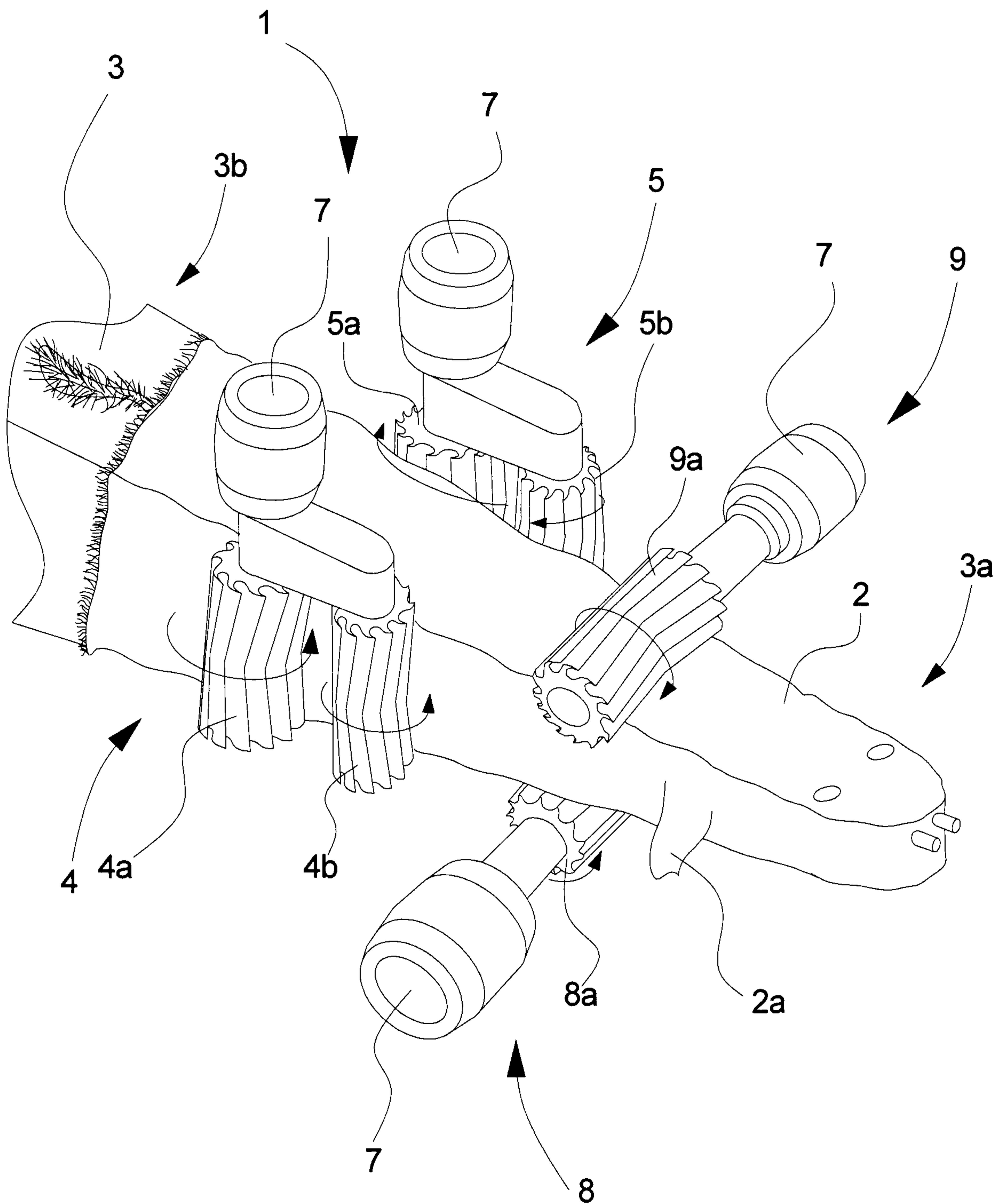

Fig. 3

4/7

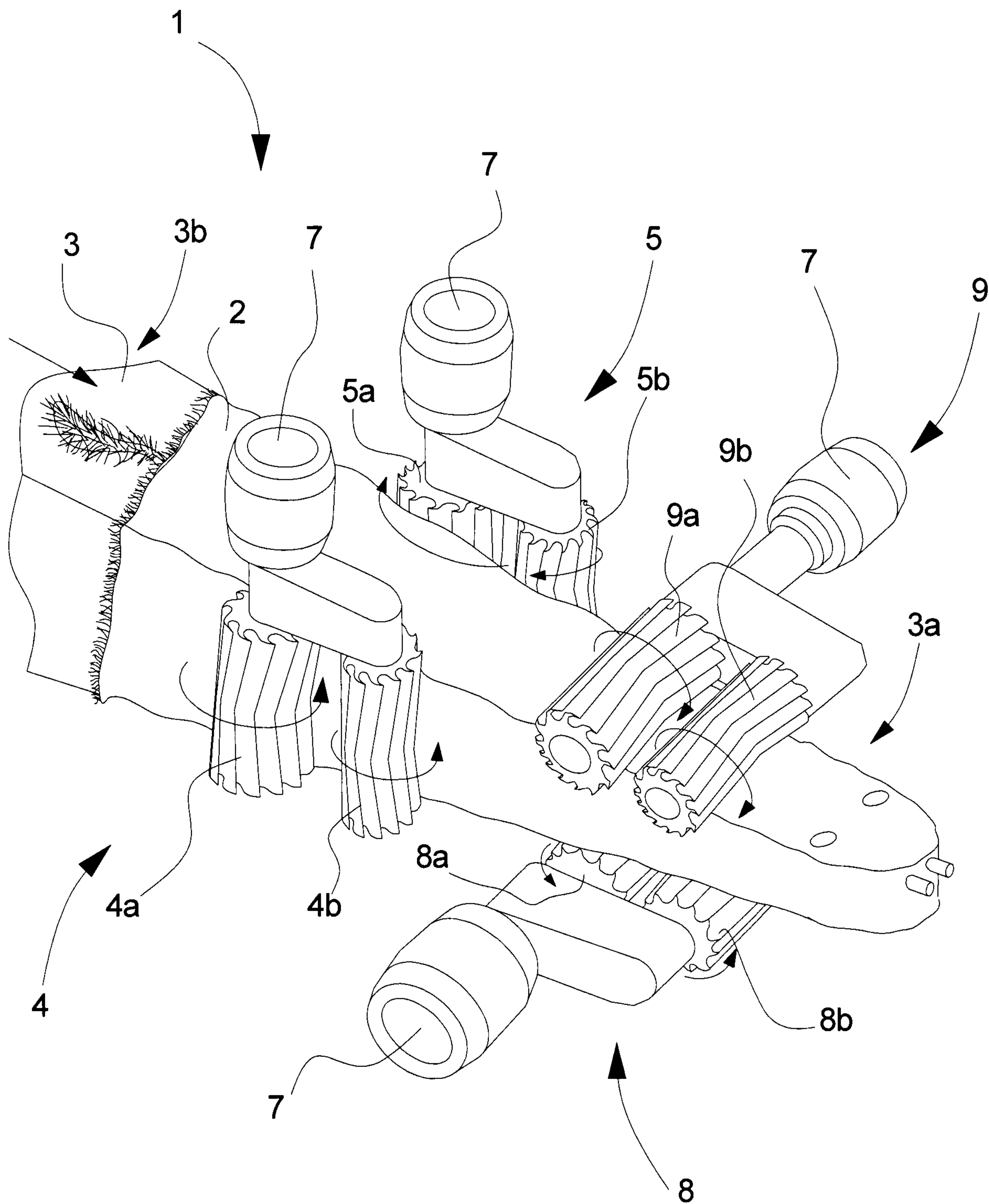

Fig. 4

6/7

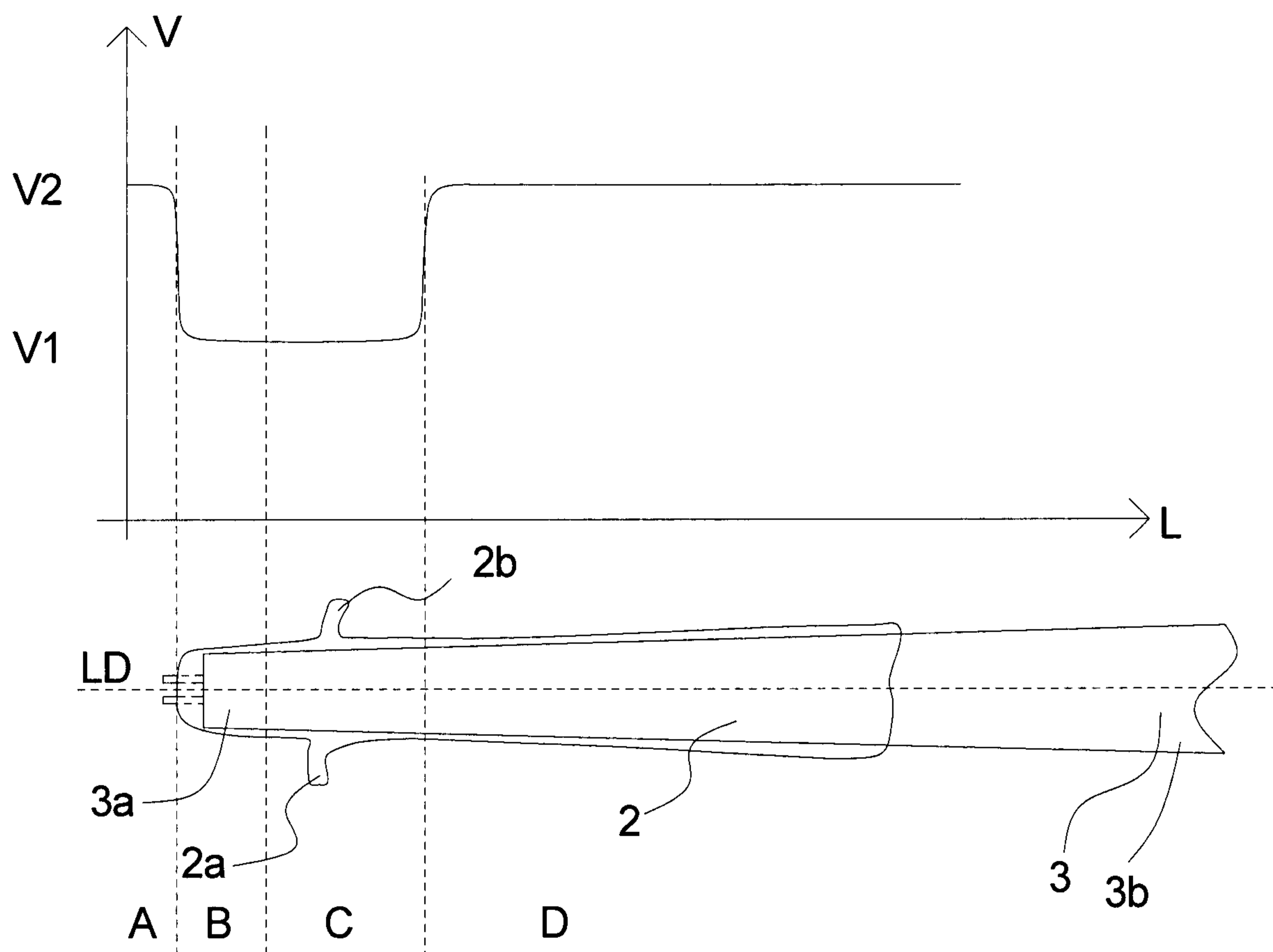

Fig. 6

7/7

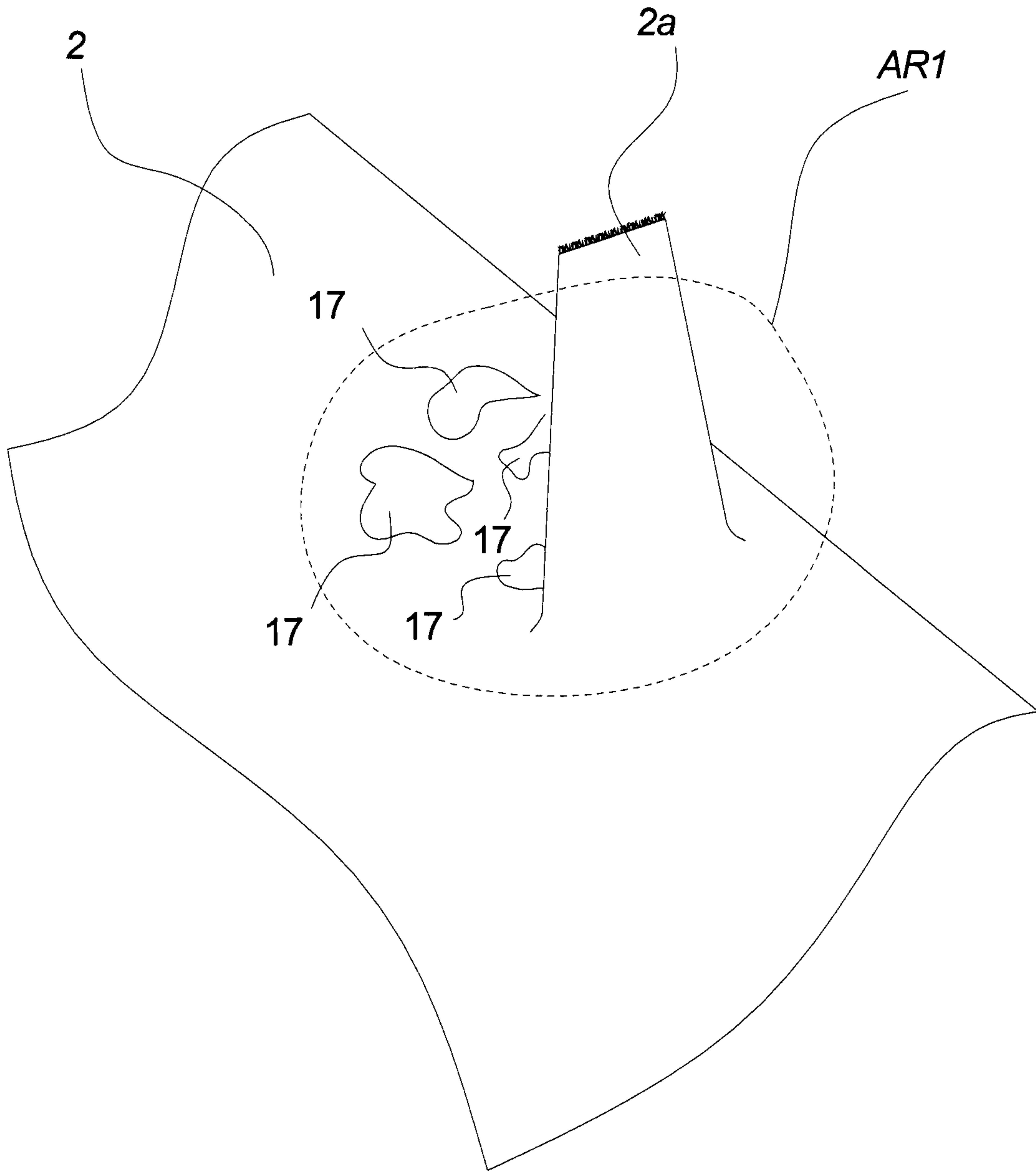

Fig. 7

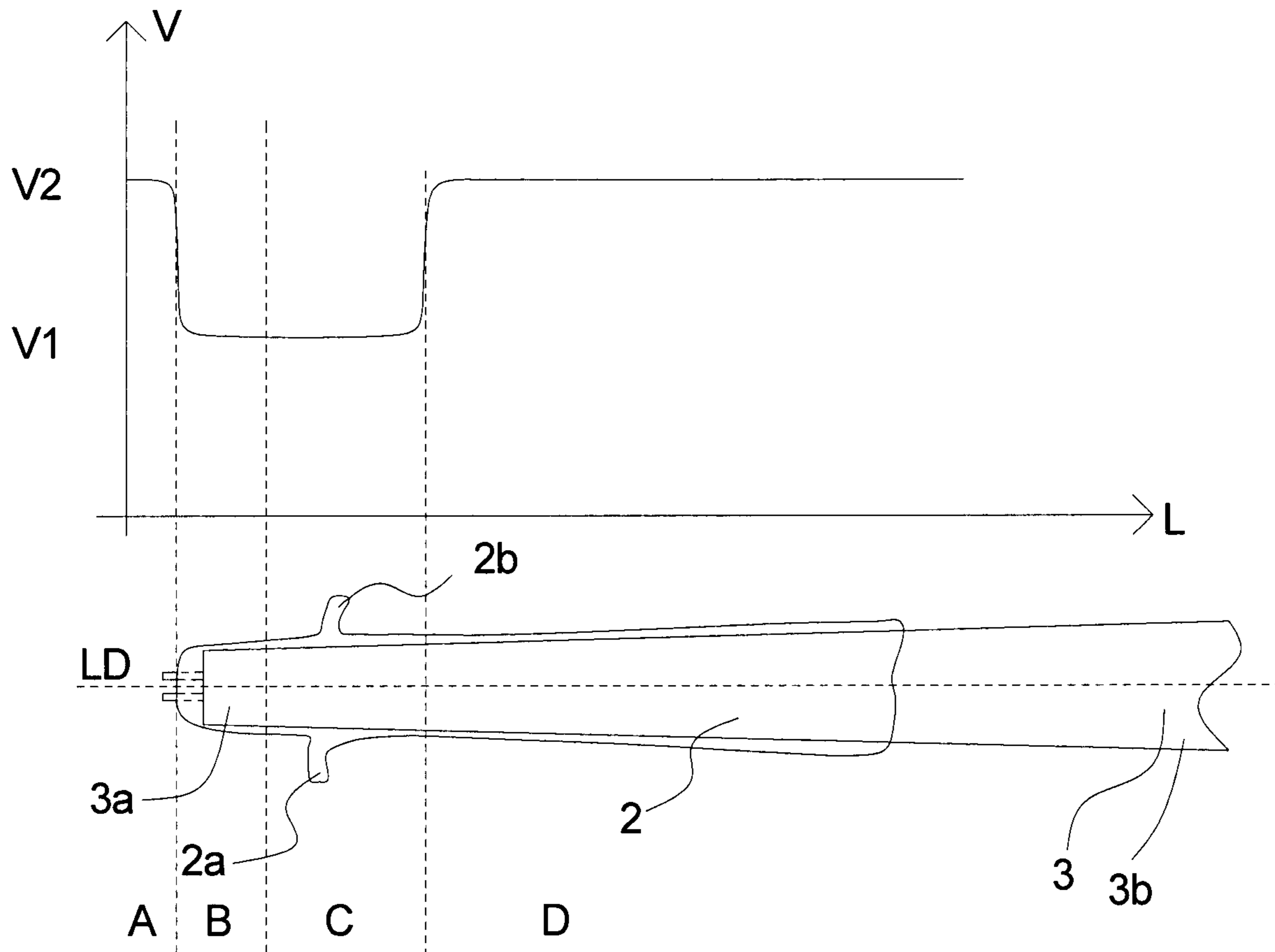

Fig. 6