

1,001,493.

Patented Aug. 22, 1911.

2 SHEETS—SHEET 1.

Fig. 1.

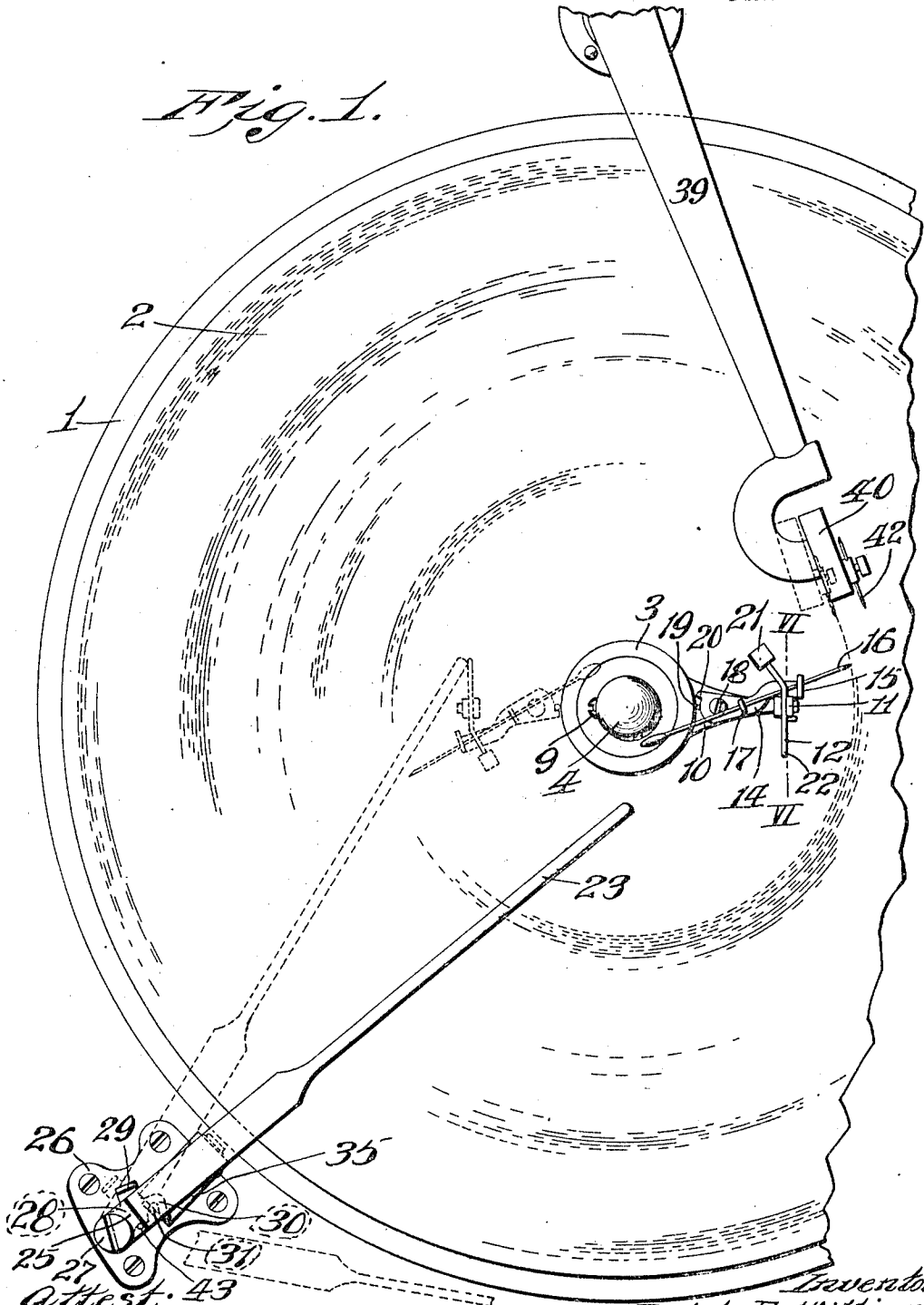

Attest: 43
L. G. Gillette
M. C. Hammon

Inventor
Ralph E. Williams
By *Fringham B. Cobys* *attys.*

1,001,493.

Patented Aug. 22, 1911.

2 SHEETS—SHEET 2.

Fig. 2.

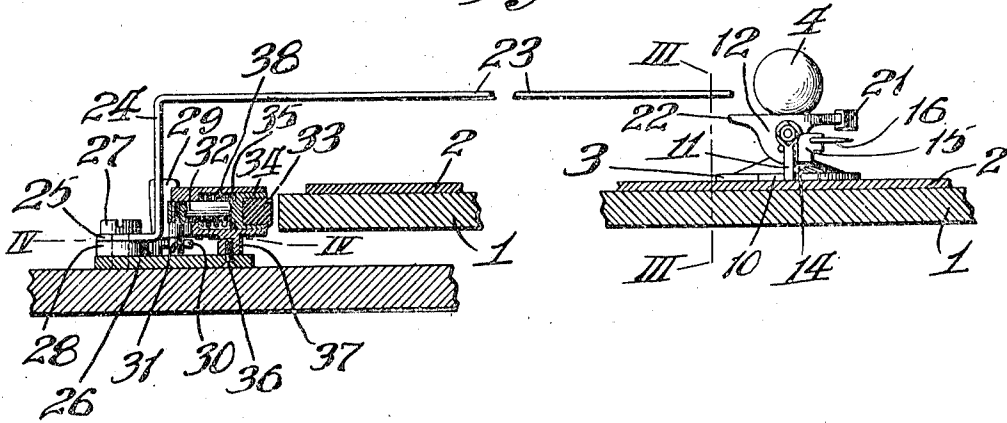

Fig. 4.

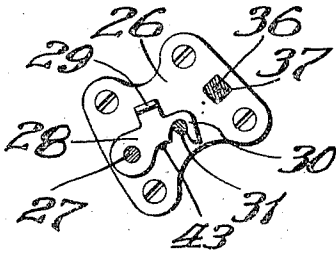

Fig. 3.

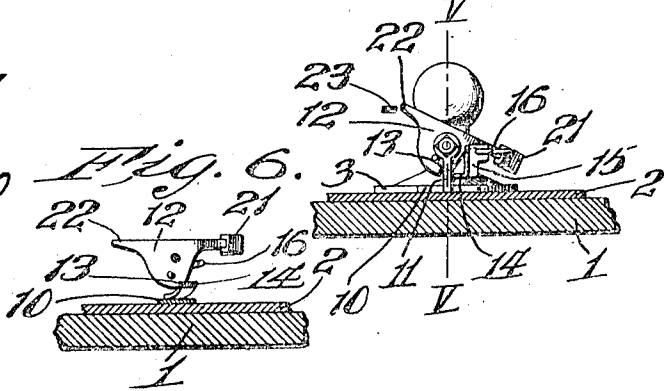

Fig. 6.

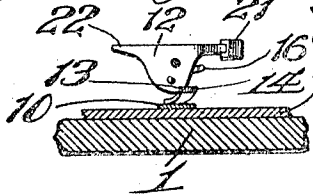
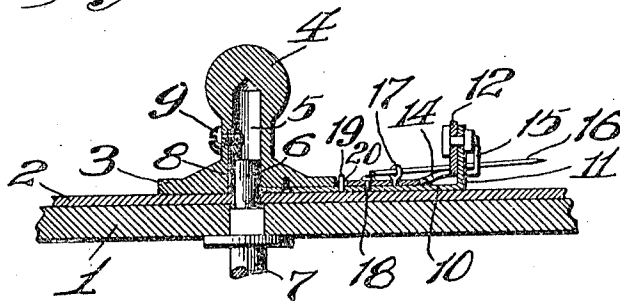

Fig. 5.



Attest:
 W. S. Fletcher.
 M. C. Hanson

Inventor:
 Ralph E. Williams.
 By Tringill & Co attys.

UNITED STATES PATENT OFFICE.

RALPH E. WILLIAMS, OF ST. LOUIS, MISSOURI.

GRAMOPHONE-STOP.

1,001,493.

Specification of Letters Patent. Patented Aug. 22, 1911.

Application filed March 3, 1911. Serial No. 611,987.

To all whom it may concern:

Be it known that I, RALPH E. WILLIAMS, a citizen of the United States, residing at St. Louis, in the State of Missouri, have invented certain new and useful Improvements in Gramophone-Stops, of which the following is a specification.

This invention relates to gramophone stops, and has for its primary object to provide an improved construction, combination and arrangement of parts in devices of this character whereby it may be adapted for use with different sized records, made very delicate in operation, and by means of which it may be readily adjusted to effect the braking action when the sound box has reached a certain point more or less distant from the center of the disk.

Other and further objects will appear in the specification, and be specifically pointed out in the appended claims, reference being had to the accompanying drawings exemplifying the invention, and in which—

Figure 1 is a plan view of a gramophone provided with my improved braking device. Fig. 2 is partial side elevation of the same, partly broken away, and parts being shown in section. Fig. 3 is a section on the line III—III, Fig. 2, showing the brake-operating mechanism in operative position. Fig. 4 is a section on the line IV—IV, Fig. 2. Fig. 5 is a fragmentary section through the axis of the turn table having a disk record mounted thereon. Fig. 6 is a section on the line VI—VI, Fig. 1.

The present invention contemplates the provision of improved means for automatically stopping a disk gramophone at the end of a selection, said means being adjustable to adapt it for use with records which end at different distances from the center and according to which a trip adjustment device is mounted adjacent the center of the disk which is operable under very delicate pressure from a part moving with the sound box, the brake being applied independently of the sound box and at the rim of the disk where it is most efficient. In carrying out these purposes of the invention, the adjustable trip comprises a durable but very delicately mounted trip lever which is weighted to throw it into position to engage a brake-releasing lever and a stop which normally maintains the trip lever in inoperative position, but which by very slight pressure from the sound box or needle carried thereby, is

moved into release position. Furthermore, my improved automatic stop can be attached without alterations to almost any of the gramophones on the market and may be applied to all the other machines by the provision of a few additional attachments, depending on the make and style of the machine.

Referring more particularly to the drawings, the turntable 1 of the gramophone has mounted thereon a disk record 2 which is retained in position by a center plate 3 provided above with an integral knob or handle 4 by means of which it may be lifted. Said center plate and knob are provided with a center bore 5 adapting it to fit over the reduced end portion 6 of the gramophone spindle 7, a clamping spring 8 being secured to the inner wall of the bore 5 by a screw 9. Projecting from the center plate 3 is a radial arm 10 provided with an upwardly deflected portion 11 which provides a pedestal or support for a tripping lever 12, said tripping lever 12 being provided with a recess forming a shoulder 13 which is normally engaged by a release lever 14 whose outer end is provided with an upwardly projecting support 15 through a perforation in which extends a rod or pin 16. The inner end of the pin 16 is supported by an eyelet 17 or other suitable means carried by the release lever 14. Said release lever 14 swings about a pivot 18 and has its movement limited by a stop pin 19 in the path of movement of a projection 20 formed on said release lever. As shown best, in Fig. 1 of the drawings, the trip lever 13 has one end deflected and provided on the extremity of that end with an enlarged portion or weight 21 which, when the release lever 14 is moved laterally in the manner to be hereinafter set forth, permits the trip lever 13 to assume the position shown in Fig. 3 in which its other end 22 in the form of a finger is elevated to a position in which it will engage the inner end of a brake-operating lever 23. Said brake operating lever 23 is provided with a downwardly projecting portion 24 with a deflected foot 25 pivotally mounted, in the present embodiment, upon a base plate 26 by means of a pivot screw 27. Pivotaly mounted upon the same screw 27 is a stop engaging lever 28 having an upwardly projecting finger hold 29 and provided on its outer swinging end with a hook or cam 30 which is adapted to slidably

engage a cam pin 31 projecting downwardly from the slide bar 32 of a resiliently mounted brake pawl. Said brake pawl is adapted to impinge the periphery of the turntable 1 by having a pad 33 of rubber or other suitable material mounted in an enlarged socket head 34 which slides within a housing 35 which is radially secured to the base plate 26 by a screw 36 which projects into a depending portion 37 of said housing 35. A spring 38 serves to resiliently press the brake pawl against the turn-table 1.

In Fig. 1 of the drawings, a swingingly mounted sound tube 39 of well known construction is illustrated, provided on its outer end with a sound box 40. Depending from the sound box 40 is the usual needle 42 which travels over the record and sooner or later engages the pin 16 carried by the release lever 14, said pin 16 being constructed of any desired length corresponding to the range of diameters in the record disks.

The operation of my device will now be understood, and briefly stated is as follows: The pin 16 having been adjusted to bring its outer extremity adjacent the innermost record groove of the disk 2, the machine may be set in motion and left to run its course, the sound box needle 42 at the end of the record being brought into engagement with the pin 16 and serving to displace the release lever 14 by that means. When the release lever 14 is displaced laterally, the weight 21 forces the trip lever 12 into operative position in which the finger 22 thereon will be brought into engagement with the brake-operating lever 23 causing said lever to be displaced into the position shown in dotted lines in Fig. 1. By this movement of the brake-operating lever, a pin 43 which projects downwardly from the foot 25 of the brake-operating lever, is brought into engagement with the cam lever 28 causing said lever 28 to be displaced laterally to release the hook 30 from the pin 31 on the brake pawl and permitting the spring 38 to force brake pad 33 against the periphery of the turn-table.

What I claim is:

1. In a device of the character described, the combination with a turn-table of a braking element provided with means tending to move it against the periphery of said turn-table, means for holding said braking element out of engagement with the turn-table, and means operatably connected with the last said means for causing the release of the braking element and comprising a member adjacent the center of the turn-table and revolving therewith, said member being normally in an inoperative position, and means for moving said member into operative position.

2. In a device of the character described, the combination with a turntable, a sound

box and a stop for engaging said turntable, of a lever overhanging said turntable, means carried by said turntable adjacent its axis for operating said lever, said means being movable into and out of operative position, and other means operatively related to the sound box for holding the first said means in inoperative position, said other means being displaced by a member carried by the sound box when said member has reached a predetermined position.

3. In a device of the character described, the combination with a turn-table and a sound box provided with a needle movable across said turn-table, of a resiliently mounted braking element operatively related to the periphery of said turn-table, a lever for holding said braking element out of engagement with said turn-table, another lever operatably engaging the former lever, a disk retaining member at the center of said turn-table, and means carried by said retaining member for operatably engaging the second lever, said means comprising a trip lever, and means for holding said trip lever out of operative position, the last said means being adjustable radially to engage the sound box needle at different distances from the axis of the turn-table.

4. In a device of the character described, the combination with a turn-table and a sound box movable thereacross and provided with a tracing needle, of a braking device disposed adjacent the periphery of said turn-table and having an operating lever projecting across the face of said turn-table, a center piece for holding a disk in place on said turn-table, a trip lever pivotally mounted on said center piece, said trip lever being provided with means tending to hold it in position to engage said operating lever, a stop lever movable into and out of engagement with said trip lever, and means carried by said stop lever for operatively engaging the sound box needle.

5. In a device of the character described, the combination with a turn-table and a sound box movable thereacross and provided with a tracing needle, of a braking device disposed adjacent the periphery of said turn-table and having an operating lever projecting across the face of said turn-table, a center piece for holding a disk in place on said turn-table, a trip lever pivotally mounted on said center piece, said trip lever being provided with means tending to hold it in position to engage said operating lever, a stop lever movable into and out of engagement with said trip lever, and means carried by said stop lever for operatively engaging the sound box needle, said means being adjustable toward and away from the center of said turn-table.

6. In a device of the character described, the combination with a turn-table and a

5 sound box suitably supported to move across
 a record disk carried by said turn-table, said
 sound box being provided with a tracing
 needle, of a resiliently mounted brake ele-
 10 ment for engaging the periphery of the
 turn-table, a cam lever for holding said
 braking element out of engagement with
 the turn-table, an operating lever adapted
 to move said cam lever out of engagement
 15 with the braking element, said operating
 lever being disposed across the face of said
 turn-table, a disk-retaining center piece ro-
 tatable with said turn-table, a trip lever car-
 20 ried by said center piece, said trip lever be-
 ing weighted to normally hold it in a po-
 sition for engaging said operating lever, a
 stop lever normally holding said tripping
 lever out of operative position, and a pin
 25 carried by said stop lever and adapted to
 be engaged by the sound box needle.

7. In a device of the character described,
 the combination with a turn-table and a
 sound box suitably supported to move across
 a record disk carried by said turn-table,
 25 said sound box being provided with a trac-
 ing needle, of a resiliently mounted brake
 element for engaging the periphery of the
 turn-table, a cam lever for holding said
 braking element out of engagement with the

turn-table, an operating lever adapted to 30
 move said cam lever out of engagement with
 the braking element, said operating lever
 being disposed across the face of said turn-
 table, a disk retaining center piece rotatable
 with said turn-table, a trip lever carried by 35
 said center piece, said trip lever being
 weighted to normally hold it in a position
 for engaging said operating lever, a stop
 lever normally holding said tripping lever
 out of operative position, and a pin carried 40
 by said stop lever, said pin being slidably
 mounted to adapt it to engage the sound box
 needle at different distances from the center.

8. In a device of the character described,
 the combination with a turn-table, and a 45
 braking device having a member supported
 adjacent the periphery of, and overhanging,
 said turntable, of a sound box provided with
 a tracing needle and means revolving with
 said turn-table for operating said member, 50
 said means being provided with an element
 adjustable to and from the center of the
 turn-table to intercept the tracing needle at
 any desired distance from the center.

RALPH E. WILLIAMS.

In the presence of—
 J. B. MEGOWN,
 M. C. HAMMON.