



**EUROPEAN PATENT APPLICATION**

Application number : **91309955.2**

Int. Cl.<sup>5</sup> : **B65H 3/44, B65H 5/06, B65H 5/38**

Date of filing : **29.10.91**

Priority : **30.10.90 IT 6783790**

Inventor : **Olivero, Michele**  
**Via Van Gogh 2**  
**I-10088 Volpiano (Torino) (IT)**  
 Inventor : **Forlani, Riccardo**  
**Corso Bernardino Telesio 40**  
**I-10146 Torino (IT)**

Date of publication of application :  
**13.05.92 Bulletin 92/20**

Designated Contracting States :  
**DE FR GB NL**

Representative : **Abnett, Richard Charles et al**  
**REDDIE & GROSE 16 Theobalds Road**  
**London WC1X 8PL (GB)**

Applicant : **OLIVETTI - CANON INDUSTRIALE**  
**S.p.A.**  
**Via Jervis, 60**  
**I-10015 Ivrea (IT)**

**Sheet transport and alignment device.**

A sheet transport and alignment device receives sheets from a plurality of different cassettes (14,15) and feeds them towards a register means (32,34). The sheets pass along a common channel (54) towards the register means. The register means is a pair of rolls (32,34) at least one of which is metal (34). The channel is directed towards the metal roll such that sheets will first contact the metal roll and slide towards a registration zone between the two rolls where they will be correctly aligned.

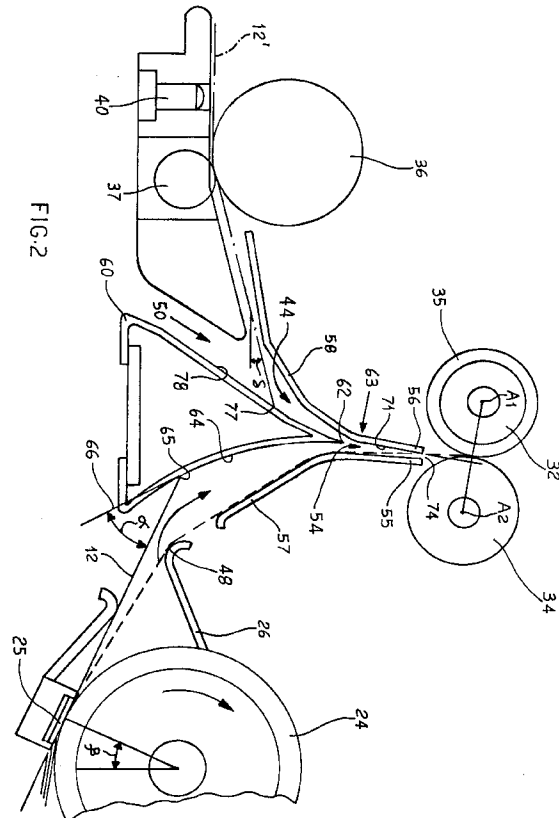

## BACKGROUND OF THE INVENTION

The present invention relates to a sheet transport and alignment device particularly suitable for an image-reproducing machine, such as a laser printer, an electro-photocopier or other similar office machinery.

More particularly, the present invention relates to a device for conveying sheets of paper coming selectively from more than one direction to the register rolls or sheet alignment rolls, in such a way that each sheet is correctly positioned against the register or alignment rolls in the direction of advance.

American Patent No. 4403851 discloses a copier in which the sheets of paper are taken selectively from different paper stacks, such as a first and a second cassette of conventional type, each containing around 250 sheets each, a large cassette positioned under the copier and containing about 1000 sheets, and a channel for the manual introduction of one sheet at a time, also known as a "by-pass". The sheets of paper are conveyed along three channels all leading to a zone immediately upstream of a pair of register rolls.

However, in this copier no means is employed for ensuring that each sheet of paper arriving from any of the various stacks is correctly positioned between the register rolls. It is therefore possible for some sheets to be introduced between the register rolls while imperfectly aligned with the direction of advance, and paper jams are then unavoidable.

## SUMMARY OF THE INVENTION

The invention is defined in its various aspects in the appended claims to which reference should now be made.

A preferred embodiment provides a device for transporting sheets of paper arriving from different stacks or directions to a registration device for alignment of the sheet. A feed device takes sheets from a cassette and forwards them to a common registration device along a feed path. There is a common channel along which the sheets pass towards a metal roll in the registration zone and the common channel is directed towards this metal roll. Sheets of paper slide freely against the metal roll. They will therefore align themselves correctly between the metal roll and an adjacent roll against which the metal roll bears.

Preferably the adjacent roll is formed of rubber.

## DESCRIPTION OF A PREFERRED EMBODIMENT

The features of the invention will become clearer with the following description of a preferred embodiment, given as a non-limiting example with reference to the accompanying drawings, in which:

Fig. 1 is a diagrammatic view of a laser printer

using the sheet transport device according to the invention;

Fig. 2 shows the conveying and registration unit of the paper transport device of Fig. 1;

Fig. 3 shows an enlarged detail of the unit of Fig. 2;

Fig. 4 is a diagrammatic illustration of the arrangement of the auxiliary paper cassette for the printer of Fig. 1.

With reference to Fig. 1, the sheet transport device according to the invention is introduced, for example, into a laser printer 10. It should be understood that this device may be fitted either to an electro-photocopier or to any office information processing machine in which the information is to be printed on sheets arriving from different stacks.

The information to be printed is mostly in the form of images and/or text prepared by writing means or a personal computer, or input on a keyboard. These are not shown in the figures but may be connected to the printer by a cable.

The printer 10 can be supplied selectively with sheets 12 contained either in a main cassette 14 located inside the printer 10, or in an auxiliary cassette 15 (Fig. 4) arranged underneath the printer 10 and enclosed in a suitable unit 17 which acts as a support for the printer. The sheets can also be introduced by hand through a slot 18 in the left-hand side (Fig. 1) of the printer 10.

The printer 10 comprises a developer unit DU of known type for developing, by means of a toner, the information supplied by a logical processing unit LU and transmitted to the developer unit DU by means of a laser beam LR emitted by a laser generator LG. The developed information is transferred to each sheet in a transfer station TS facing the developer unit DU. Next, the sheet 12 runs through a fixing station FU formed by two fusing rolls 80, 81 which fix the toner particles to the sheet by heat.

After the fixing operation the sheet is advanced along guides 83 and then transported by rolls R into a delivery tray T at the top of the printer.

The cassette 14 can be taken out for refilling with fresh sheets through an opening 22 on the left in Fig. 1 after opening a door 23.

The sheets 12 are taken from the cassette 14 one at a time by means of a clockwise rotating sheet separator roll 24 interacting with a friction block 25 to block the path of second sheets that may be stuck to the required sheet 12.

The roll 24 is mounted on an auxiliary frame 26, hinged to the structure of the printer at a point 27. The frame 26 can be swung up in the direction of the arrow 28, to allow the cassette 14 to be taken out.

Downstream of the roll 24, the sheet 12 pushed by the sheet separator roll 24 enters a first channel 30 that curves upwards towards a pair of register rolls 32 and 34 lying a short distance ahead of the developer

unit DU, in the direction of advance of the sheet.

The roll 32 is covered with a soft rubber sheet 35, while the roll 34 is of ground and polished steel. The rolls 32 and 34 are pressed against each other to define a registration or contact zone into which the front edge of a sheet is introduced in order correctly to align the sheet with respect to the direction of advance.

The rolls 32 and 34 are normally stationary, but after a sheet has been introduced into the registration zone, they are rotated in order to pass the sheet towards the developer unit DU.

When information is to be printed on a sheet 12' inserted manually into the slot 18, the sheet 12' is pushed manually against a pair of rotatable rolls 36, 37 that press against each other. The roll 36 is started by its own electric motor 38, while the roll 37 is idle. A sensor 40 is placed immediately before the point of contact of the rolls 36, 37 so as to signal the presence of the sheet 12' to a logic unit LCU which controls all the operations performed by the printer 10.

Whenever a sheet 12' is inserted into the slot 18, the unit LCU, on a signal from the sensor 40, first starts the motor 38 for a short time so that the sheet 12' is drawn a short way in, for example 20 mm, past the point of contact of the rolls 36, 37. The motor 38 is then stopped in order to hold the sheet 12' still until the operator presses a button (not shown) to start the print cycle.

In this way, the sheet 12' does not need supporting either by the operator or by a projecting bracket, and the absence of such a bracket enables the size of the printer to be reduced.

When the operator presses the start cycle button, the motor 38 starts again and forwards the sheet 12' to the register rolls 32, 34 through a second channel 44 that curves upwards towards the rolls 32, 34.

When, instead, the auxiliary cassette 15 under the printer 10 is used (Fig. 4) the sheets 12" which it contains, and which may be of a different format from those in the main cassette 14, are forwarded to the register rolls 32, 34 by a sheet separator roll 45 and by a pair 47 of forwarding rolls. The rolls 47 push a sheet 12" along a third channel 50 (Fig. 1) delimited by a guide 51 and by the outer surface of a projection 52 of the cassette 14. The third channel 50 joins up with the second channel 44 downstream of the roll 36. The first and second channels arrive from two substantially opposite directions and join up in a single channel 54 leading to the zone of contact of the rolls 32, 34 in a direction substantially perpendicular to the direction of the first and second channels.

The channel 54 (Fig. 2) is delimited by two end portions 55 and 56 of two walls or guides 57 and 58 respectively delimiting the first channel 30 and the second channel 44. The channels 30 and 44 are in turn separated by a part 60 of substantially triangular cross-section and having a vertex 62 in the lower part

63 of the channel 54. The part 60 delimits the channel 30 with a curved wall 64 which encourages the front edge 65 of a sheet 12 pushed by the sheet separator roll 24 to slide toward the channel 54.

It is known that this sliding occurs correctly without sticking when the angle of incidence " $\alpha$ " between the direction of advance of the sheet 12 and the tangent 66 to the guide at the point of contact of the edge 65 of the sheet is less than a critical value of approximately  $40^\circ$ .

To satisfy this condition, therefore, the block 25 is moved angularly in the direction of rotation of the roll 24 by an angle " $\beta$ " of approximately  $25^\circ$  in such a way that the sheet 12 slides up the wall 64 with an incidence of less than  $40^\circ$ . The sheet then moves up the channel 30 guided by a curved projection 48 from the frame 26 and by the wall 57 and so enters the channel 54.

Since during this phase in the feeding of the sheets 12, 12' or 12" the register rolls 32, 34 are stationary, then in order to avoid having the front edges of the sheets 12, 12', 12" coming into contact with the rubber roll 32, the channel 54 is directed towards the steel roll 34. The reason for this is that if the front edge of the sheet were to touch the rubber roll 32 before reaching the registration or contact zone between the rolls 32 and 34, the sheet could misalign itself with the direction of advance and so bring about a jam. On the other hand, when the front edge of the sheet touches the steel roll first, the sheet slides on its surface and feeds itself exactly into the registration zone between the rolls 32 and 34. In this way the sheet aligns itself correctly with respect to the direction of advance with a further push from the sheet separator roll 24. Hence (Fig. 3) the wall 56 is inclined towards the steel roll 34 in order that an imaginary projection 70 of the internal surface 71 passes at a distance "b" from the contact or registration zone between the rolls 32, 34.

The distance "b" is between 1 and 2 mm and is measured along the radius "R" of the roll 34 passing through the registration zone.

The walls 55 and 56 may be parallel with each other, but preferably converge upwards at an angle of convergence " $\gamma$ " of between  $4^\circ$  and  $6^\circ$ , with a gap between them forming an exit slot 74 whose width is between 0.8 and 1.2 mm.

For optimum introduction between the rolls 32 and 34 of the front edge of each sheet 12, 12' or 12", it has been found that the distance "c" between the vertex 62 of the part 60 and the straight line joining the axes A1 and A2 of the rolls 32 and 34 should be between 13 and 18 mm, while the length "l" of the channel 54 should be not less than 8 mm. In every case it is preferable for the distance "d" between the edge 56' of the wall 56 and the roll 34 to be not less than 1.5 mm.

The rolls 36, 37 (Fig. 2) are arranged so as to push the sheet 12' in an upwardly inclined direction at

an angle "δ" of approximately 15°, so that the front edge 77 slides without sticking over the wall 78 of the part 60. The rolls 36, 37 push the sheet 12' along the wall 78, through the channel 54 and finally up against the steel rolls 34. At this point the front edge 77 of the sheet 12' feeds itself between the stationary rolls 32 and 34, where it is correctly positioned by the thrust from the rolls 36, 37 in the same way as described for the sheet 12. As already indicated previously, the toner particles transferred in the station TS (Fig. 1) onto one side of the sheet 12, are fixed to the paper by heat by means of two rotating rolls 80 and 81 pressing against each other, between which the sheet 12 is passed.

The roll 80 is of rubber and comes into contact with the back of the sheet. The roll 81 is of Teflon-coated metal (M.R.) and is heated to approximately 180°C.

Sheets emerging from the fixing station FU are then forwarded by guides 83 and rolls R to the delivery tray T.

It will be understood that modifications, additions or substitutions of parts may be made to the sheet transport device without thereby departing from the scope of the invention.

## Claims

1. A sheet transport and alignment device comprising container means (14,15) containing a plurality of sheets (12), a plurality of feed devices (24,45) for taking said sheets out of respective container means and forwarding them to a register means (32,34) along at least one path (30), an additional introduction device (36,37) for introducing at least one sheet and forwarding it to said register means along a second path (44) oriented in a different direction with respect to the direction of said first path, said register means comprising at least one metal roll (34) defining a registration zone, characterised in that said first and second paths (30,44) converge towards a common channel (54) directed substantially towards said metal register roll (34) to ensure correct insertion of said sheets (12) into said registration zone in alignment with the direction of advance of the sheets.
2. A sheet transport and alignment device according to claim 1, characterised in that said first and second paths (30,44) are separated by a part (60) of triangular cross-section having a vertex (62) at one end of said common channel and delimited by first and second curved walls (64,78) having in common said vertex.
3. A sheet transport and alignment device according to claim 1 or 2, characterised in that said first path

is oriented in a direction substantially the opposite of the direction of said second path, and in that said common channel (34) is oriented substantially in a direction perpendicular to said first and second paths.

4. A sheet transport and alignment device according to one of the preceding claims, characterised in that said common channel (54) is delimited by two plane walls (55,56), and in that an imaginary projection of one of said walls passes at a distance (b) from said registration zone of between 1 and 2 mm towards said metal roll (34).
5. A sheet transport and alignment device according to claim 4, characterised in that said distance is measured along a radius of said roll passing through said registration zone.
6. A sheet transport and alignment device according to either of claims 4 and 5, characterised in that said two plane walls (55,66) are parallel.
7. A sheet transport and alignment device according to either of claims 4 and 5, characterised in that said two plane walls are mutually convergent at an angle of convergence of between 4° and 6°.
8. A sheet transport and alignment device according to one of the preceding claims, characterised in that said common channel is not less than 8 mm in length.
9. A sheet transport and alignment device according to one of claims 2 to 8, characterised in that said feed means comprise a sheet separator block (25) associated with a feed roll (24) and in that said block (25) is oriented with respect to said feed roll (24) in such a way that said feed roll pushes a sheet against said first curved wall (64) at an angle of incidence  $\alpha$  that is less than a pre-determined critical value.
10. A sheet transport and alignment device according to one of claims 2 to 8, characterised in that said introduction device comprises a pair of rolls (36,37) oriented in such a way that a sheet is pushed against said second curved wall (78) at an angle of incidence that is less than said critical value.
11. A sheet transport and alignment device according to claim 9 or 10, characterised in that said angle of incidence has a critical value of approximately 40°, in order to ensure that the front edge of said sheets slides freely over said first and second curved walls without sticking.

12. A sheet transport and alignment device according to one of the preceding claims, characterised in that said introduction device holds onto a sheet (12) inserted manually between said oriented rolls indefinitely until print cycle is started. 5

13. A sheet transport and alignment device comprising a plurality of feed devices (24,25) for feeding sheets (12) to a register means, the register means comprising a pair of adjacent rolls (32,34), at least one of which is metal, defining a registration zone therebetween, characterised in that sheets are fed along a common channel (54) directed substantially towards said metal roll (34) to ensure correct alignment of the sheets in the registration zone. 10 15

20

25

30

35

40

45

50

55

5

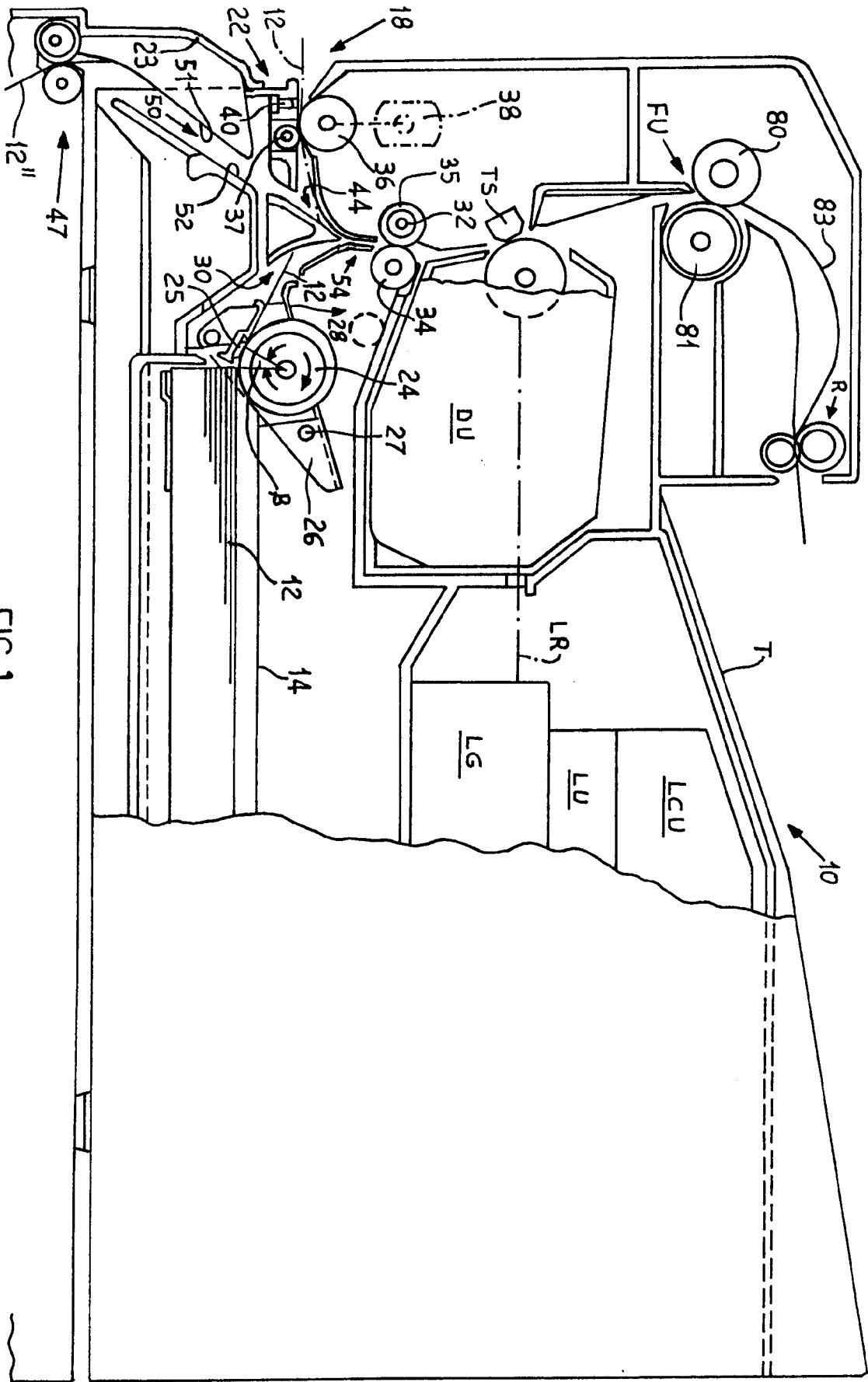

FIG.1



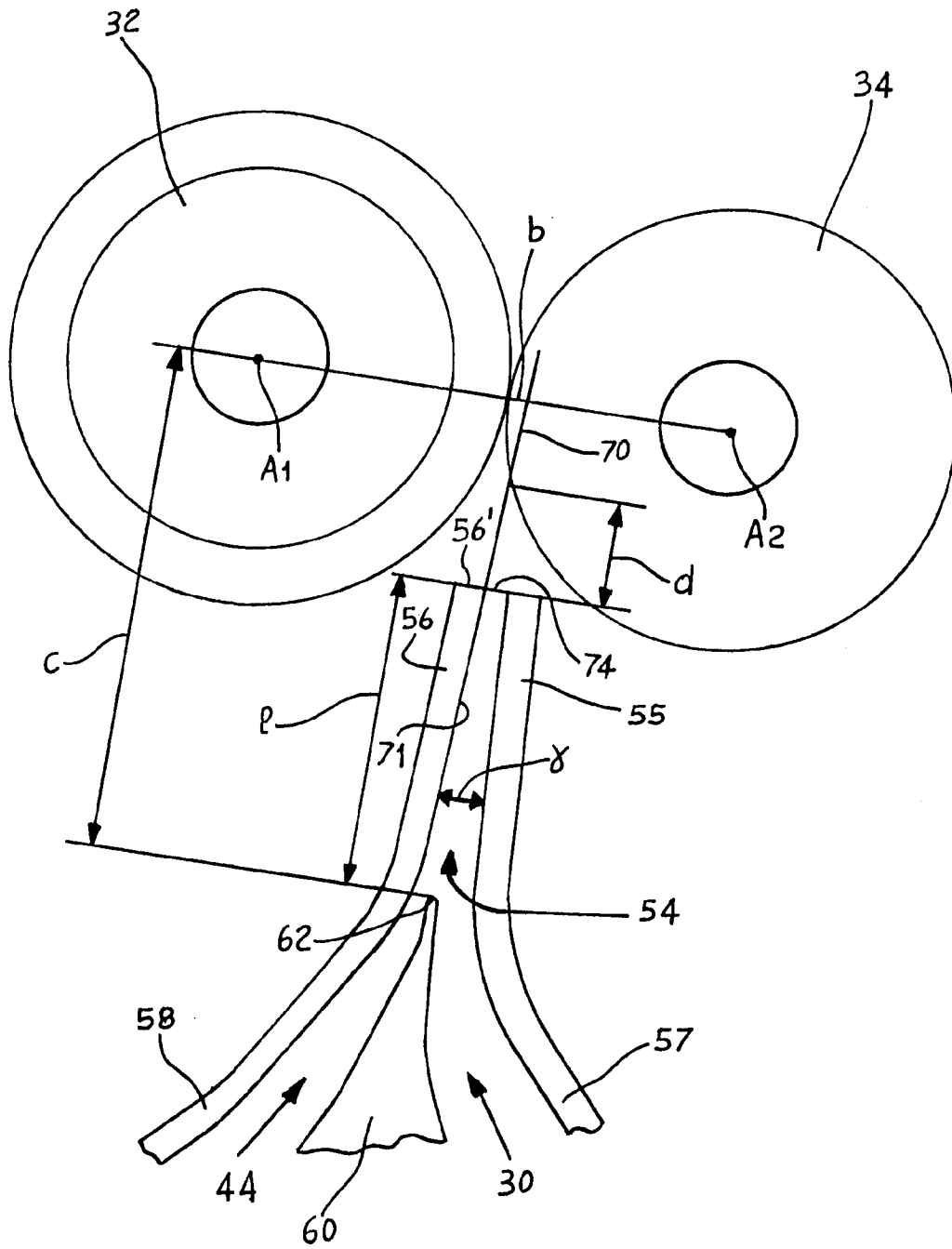

FIG.3

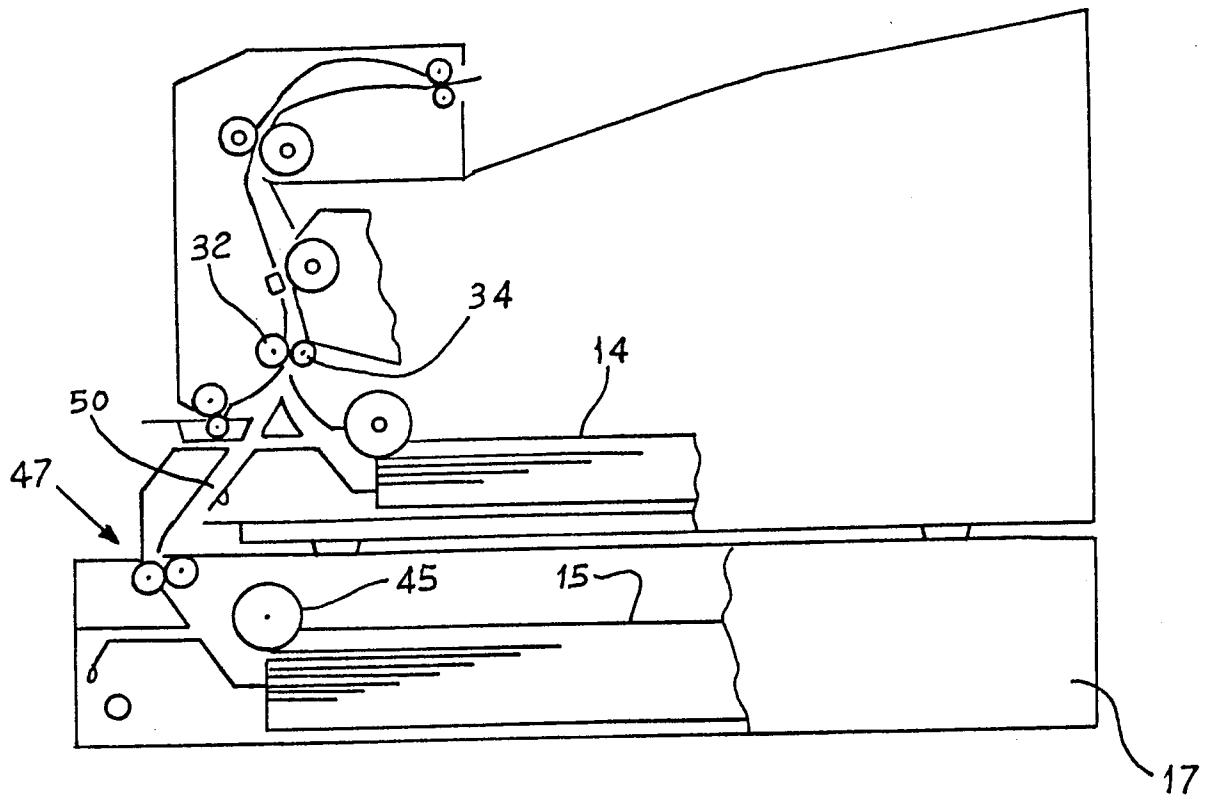

FIG.4



European Patent  
Office

EUROPEAN SEARCH REPORT

Application Number

EP 91 30 9955  
Page 1

DOCUMENTS CONSIDERED TO BE RELEVANT			
Category	Citation of document with indication, where appropriate, of relevant passages	Relevant to claim	CLASSIFICATION OF THE APPLICATION (Int. Cl.5)
D, Y	US-A-4 403 851 (YANAGAWA)  * column 8, line 42 - column 10, line 46; figures 2,6-8 * ---	1-5, 7-10, 12, 13	B65H3/44 B65H5/06 B65H5/38
Y	PATENT ABSTRACTS OF JAPAN vol. 12, no. 31 (M-663)(2878) 29 January 1988 & JP-A-62 185 653 ( HITACHI LTD ) 14 August 1987 * abstract * ---	1-5, 7-10, 12, 13	TECHNICAL FIELDS SEARCHED (Int. Cl.5)  B65H
Y	PATENT ABSTRACTS OF JAPAN vol. 14, no. 351 (M-1003)(4294) 30 July 1990 & JP-A-2 123 042 ( CANON INC ) 10 May 1990 * abstract * ---	2, 3	
Y	PATENT ABSTRACTS OF JAPAN vol. 12, no. 121 (M-686)(2968) 15 April 1988 & JP-A-62 249 842 ( RISO KAGAKU CORP. ) 30 October 1987 * abstract * ---	9	
Y	DE-A-3 317 910 (TOKYO SHIBAURA DENKI K.K.)  * page 10, line 25 - page 11, line 26; figures 1-3 * ---	1, 4, 5, 7-9, 12, 13	
Y	PATENT ABSTRACTS OF JAPAN vol. 9, no. 245 (M-418)(1968) 2 October 1985 & JP-A-60 097 150 ( TOSHIBA K.K. ) 30 May 1985 * abstract * ---	1, 4, 5, 7-9, 12, 13	
Y	EP-A-0 367 201 (CANON KABUSHIKI KAISHA) * figures 9-11 * ---	9	
-/--			
The present search report has been drawn up for all claims			
Place of search THE HAGUE		Date of completion of the search 27 FEBRUARY 1992	Examiner KOCH J. M. L.
CATEGORY OF CITED DOCUMENTS		T : theory or principle underlying the invention E : earlier patent document, but published on, or after the filing date D : document cited in the application L : document cited for other reasons ..... & : member of the same patent family, corresponding document	
X : particularly relevant if taken alone Y : particularly relevant if combined with another document of the same category A : technological background O : non-written disclosure P : intermediate document			

EPO FORM 1503 03.82 (P0401)



European Patent  
Office

EUROPEAN SEARCH REPORT

Application Number

EP 91 30 9955  
Page 2

DOCUMENTS CONSIDERED TO BE RELEVANT			
Category	Citation of document with indication, where appropriate, of relevant passages	Relevant to claim	CLASSIFICATION OF THE APPLICATION (Int. Cl.5)
A	PATENT ABSTRACTS OF JAPAN vol. 12, no. 260 (M-720)(3107) 21 July 1988 & JP-A-63 041 338 ( CANON INC. ) 22 February 1988 * abstract *	1-4, 7, 8, 12, 13	
			TECHNICAL FIELDS SEARCHED (Int. Cl.5)
The present search report has been drawn up for all claims			
Place of search THE HAGUE		Date of completion of the search 27 FEBRUARY 1992	Examiner KOCH J. M. L.
CATEGORY OF CITED DOCUMENTS X : particularly relevant if taken alone Y : particularly relevant if combined with another document of the same category A : technological background O : non-written disclosure P : intermediate document		T : theory or principle underlying the invention E : earlier patent document, but published on, or after the filing date D : document cited in the application L : document cited for other reasons ..... & : member of the same patent family, corresponding document	

EPO FORM 150 (03.82) (P0401)