

[54] SIEVING

[75] Inventors: Robert William Allen, Disley; John Drane, Stockport, both of England

[73] Assignee: Henry Simon Limited, Stockport, England

[22] Filed: March 27, 1970

[21] Appl. No.: 23,393

[30] Foreign Application Priority Data

May 28, 1969 Great Britain.....27,097/69

[52] U.S. Cl.209/240, 209/246, 209/256, 209/321, 209/373

[51] Int. Cl.B07b 1/00

[58] Field of Search.....209/321, 325, 326, 371, 373, 209/259, 258, 240, 246, 256, 243, 236, 315, 318, 312

[56] References Cited

UNITED STATES PATENTS

2,047,713 7/1936 Simpson209/240
3,010,576 11/1961 Harte et al.209/133 T X

FOREIGN PATENTS OR APPLICATIONS

1,177,873 4/1959 France209/321

Primary Examiner—Frank W. Lutter
Assistant Examiner—William Cuchlinski, Jr.
Attorney—Norris & Bateman

[57] ABSTRACT

A method of sieving characterized by the inclusion of the step of forcing a current of air through the sieve co-currently with the material being sieved, whereby to achieve an increased throughput rate of the material being sieved, and apparatus for practicing such methods.

8 Claims, 1 Drawing Figure

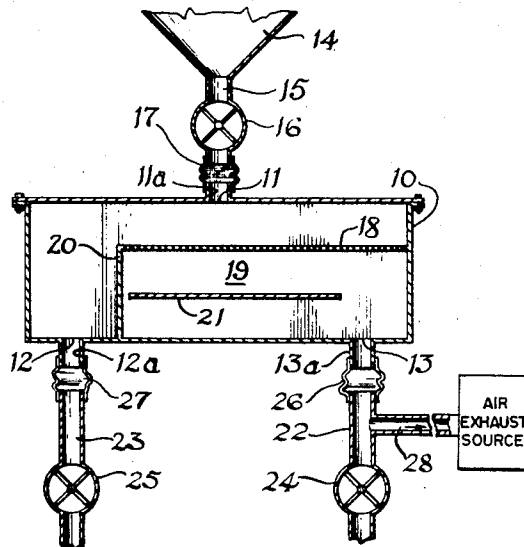

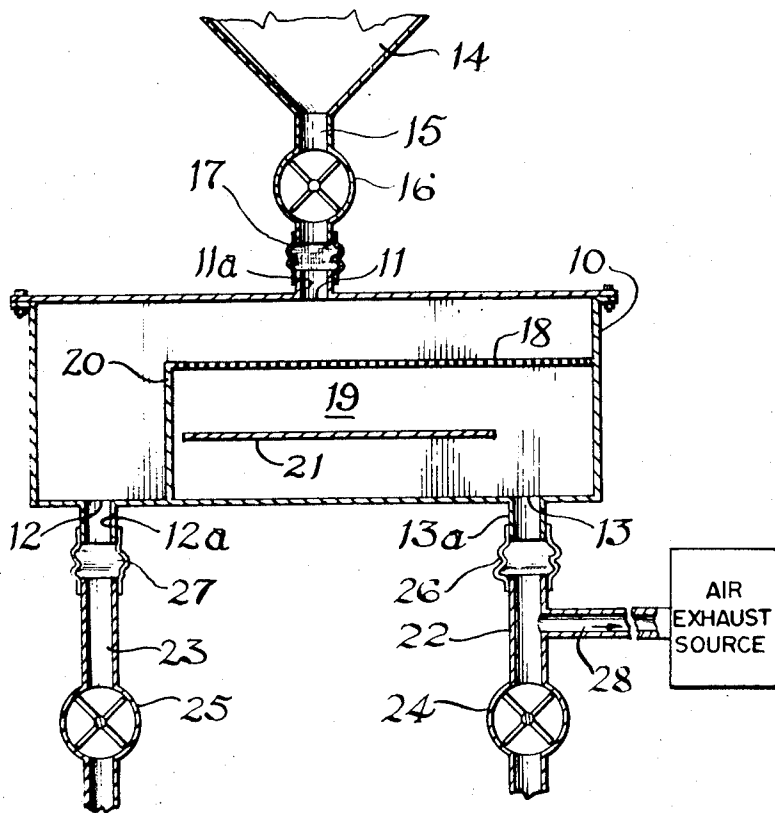

Inventors

ROBERT WILLIAM ALLEN and

JOHN DRANE

Attorneys

Norris & Balaban

SIEVING

This invention concerns sieving and has particular, though by no means exclusive, reference to the sieving of flour.

According to the invention a method of sieving is characterized by the inclusion of the step of forcing a current of air through the sieve co-currently with the material being sieved, whereby to achieve an increased throughput rate of the material being sieved.

Also according to the invention is sieving apparatus for practising the method aforesaid.

The invention will be further apparent from the following description, with reference to the single figure of the accompanying drawing, which shows, by way of example only, a diagrammatic cross-section through one form of sieving apparatus embodying the invention and for practising the method thereof.

Referring now to the drawing, it will be seen that the apparatus comprises a chamber generally indicated at 10, provided with an inlet port 11 in its upper wall which communicates with a cuff 11a and through which stock to be sieved may be fed to the interior of the chamber. The chamber 10 is provided with outlet ports 12 and 13 at opposite sides of its lower wall which communicate with cuffs 12a and 13a providing passages which allow the "overtails" and "throughs" to be conveyed from the chamber respectively.

The stock is fed from a hopper 14 or other feed device to a duct 15 which incorporates a rotary air lock device 16 which by virtue of rotation of the vanes therein enables the stock to pass therethrough whilst preventing the direct passage of air. The lower end of the duct 15 is connected with the cuff 11a by means of a foraminous and flexible sleeve 17 of canvas, for example.

The stock which enters the chamber 10 falls onto a sieve screen 18 disposed horizontally within the chamber 10 and forming the upper surface of a subsidiary chamber 19 which is otherwise sealed from the interior of the chamber 10 by a wall 20.

During sieving the throughs passing through the screen 18 fall onto a tray 21 and are thence directed to fall towards the port 13 for exit from the chamber, whilst overtails fall off the screen 18 towards the port 12 for exit from the chamber.

The throughs and overtails are conveyed away through ducts 22 and 23 incorporating rotary air locks 24 and 25 similar to that 16 described hereinbefore. The upper ends of the ducts 22 and 23 are connected with the cuffs 13a and 12a by flexible impervious sleeves 26 and 27 of plastics material, for example. Cuff 13a, sleeve 26 and duct 22 provide a first passage for conveying through material from the chamber. Cuff 12a, sleeve 27 and duct 23 provide a second passage for conveying overtail material from the chamber.

The chamber 10 is mounted and provided with suitable drive means (not shown) for gyratory movement thereof to promote the sieving action, and relative movement between the chamber 10 and ducts 15, 22 and 23 is accommodated by the flexible sleeves 17, 26 and 27.

A duct 28 communicates with the duct 22 at a position intermediate the rotary air lock 24 and sleeve 26. The duct 28 is connected to an air exhaustion system whereby air can be extracted from the chamber 10 dur-

ing sieving. Since the chamber, apart from the foraminous sleeve 17, is otherwise sealed from atmosphere by the rotary air locks 16, 24 and 25, extraction of air through the duct 28 causes a current of air to be drawn in at the sleeve 17 and to be forced through the screen 18 co-currently with the material being sieved.

Tests have shown that the throughput rate of material being sieved can be increased by up to 200 percent and in some cases 300 percent by the provision of the co-current flow of forced air. We have found that the throughput rate increases with increased air flow up to a maximum and then decreases with increasing air flow. The optimum air flow thus needs to be determined empirically for any given set of conditions including the nature of the material to be sieved and the screen mesh size.

It will be appreciated that it is not intended to limit the invention to the above example only, many variations being possible, without departing from the scope thereof.

Thus, for example the air flow through the screen required by the invention may be created by compression instead of suction.

What is claimed is:

1. A method of sieving wherein fluent material to be sieved is supplied continually into chamber means containing a sieve and having two discharge outlet ports, one connected to a passage for conveying from said chamber means through material that has passed through the sieve and one connected to a passage for conveying from said chamber means overtail material that has not passed through the sieve, characterized by forcing air through the sieve co-currently with material to increase the rate of material flow through the sieve while preventing said forced air from escaping at said passages with either the through material or the overtail material.

2. Sieving apparatus comprising means whereby fluent material to be sieved is supplied through an inlet port into chamber means, a sieve in said chamber means, two discharge ports for said chamber means, means defining a first passage connected to one outlet port for conveying from the chamber means through material that has passed through the sieve and means defining a second passage connected to the other outlet port for conveying from the chamber means overtail material that has not passed through the sieve, means for forcing air through the sieve co-currently with material to increase the rate of material flow through the sieve, and means for preventing said forced air from escaping at said passages with either the through material or the overtail material.

3. Sieving apparatus according to claim 2, wherein said chamber means comprises upper and lower walls defining a chamber, said sieve extending over part of the horizontal cross-section of said chamber at a position intermediate said upper and lower walls of the chamber, wall means separating that part of the chamber below said sieve from the remainder of the chamber, said inlet port being in the upper wall of the chamber means and said outlet ports being in the lower wall of said chamber.

4. Apparatus according to claim 3, wherein each said passage defining means incorporates flexible sleeve coupling means.

3

5. Apparatus according to claim 2, said means for forcing air through the sieve including means for exhausting air from said first passage communicating with the discharge outlet port adapted to pass the material that has passed through the sieve.

6. Apparatus according to claim 5, wherein said first passage contains a rotary air lock for preventing escape of the forced air, and said air exhaust means is connected to the first passage between the air lock and the associated discharge outlet port.

4

7. Apparatus as defined in claim 2, wherein means defining a passage is connected to said inlet port and rotary air locks are provided in all of said passages.

8. Apparatus as defined in claim 7, wherein the means to force air through the sieve co-currently with material comprises a flexible foraminous sleeve section disposed in said inlet passage between the air lock and the chamber means.

10

* * * * *

15

20

25

30

35

40

45

50

55

60

65