

19



Octrooi Centrum
Nederland

11

2024910

12 B1 OCTROOI

21

Aanvraagnummer: **2024910**

51

Int. Cl.:
A61H 23/02 (2020.01) A61H 1/00 (2021.01)

22

Aanvraag ingediend: **14 februari 2020**

30

Voorrang:
27 februari 2019 DK PA 2019 00243

73

Octrooihouder(s):
**Valdgård Holding ApS te Rask Mølle,
Denemarken, DK**

41

Aanvraag ingeschreven:
1 september 2020

72

Uitvinder(s):
Søren Valdgård Boye te Rask Mølle (DK)

43

Aanvraag gepubliceerd:
3 september 2020

74

Gemachtigde:
ir. M.F.J.M. Ketelaars c.s. te Den Haag

47

Octrooi verleend:
18 mei 2021

45

Octrooischrift uitgegeven:
19 mei 2021

54

An apparatus suitable for promoting healing of a pre-tibial laceration, and for preventing occurrence and reoccurrence

57

The present invention relates to an apparatus comprising:

- a chassis with a support plate, and a lateral rim delimiting the support plate, which lateral rim preferably extends downwards relative to said support plate;
- an electric vibration motor fastened to the lower face of the support plate;
- an electric infrared emitting plate element comprising a carbon membrane and being positioned above or on top of said support plate; and
- a cover plate of a polymeric material and adapted to cover at least the support plate and the electric infrared emitting plate element.

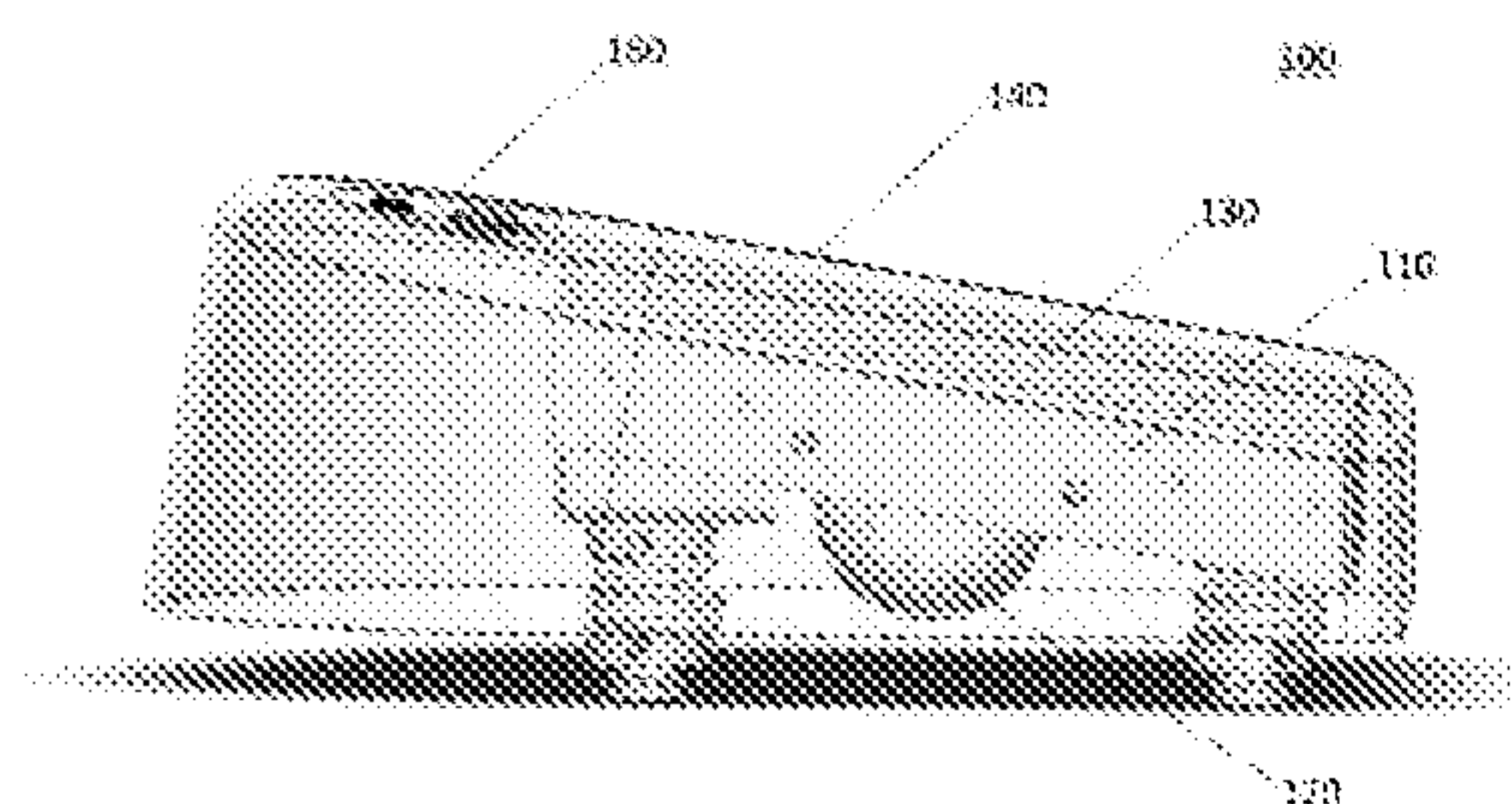

An apparatus suitable for promoting healing of a pre-tibial laceration, and for preventing occurrence and reoccurrence

Technical field of the invention

5 The present invention relates to an apparatus suitable for promoting healing of a pre-tibial laceration, and for preventing reoccurrence.

Background of the invention

Pre-tibial laceration is defined as lacerations to the anterior aspect of the lower leg.

10 Research into the treatment of these lacerations is limited. Treatment with heparin has shown a positive effect, however, the treatment is complex. As an example, US5037810 discloses that a 69-year-old female presenting torn skin of the left leg above the tibia resulting from injury to a subcutaneous hematoma was treated with heparin. Heparin solution was applied twice daily to the infected, weeping, necrotic wound, by the
15 physician in the office or by the patient at home, for 12 days. Day 1, topical heparin dose was 20,000 I.U., twice daily; reduced progressively to 2,500 I.U., twice daily, on day 12. Heparin, in 10,000 I.U. dose, was parenterally administered by injection into subcutaneous fat, once daily for 3 days.

20 Hence, there is a need for a simple solution for promoting healing of a pre-tibial laceration, and for preventing occurrence and reoccurrence.

Summary of the invention

One object of the present invention is to provide a method and means for promoting
25 healing of a pre-tibial laceration, and for preventing occurrence and reoccurrence.

A first aspect relates to an apparatus comprising:

- a chassis with a support plate, and a lateral rim delimiting the support plate, which lateral rim preferably extends downwards relative to said support plate;
- an electric vibration motor fastened to the lower face of the support plate;
- 30 - an electric infrared emitting plate element comprising a carbon membrane and being positioned above or on top of said support plate; and

- a cover plate of a polymeric material and adapted to cover at least the support plate and the electric infrared emitting plate element.

A second aspect relates to an apparatus comprising:

- 5 - a chassis with a support plate, and a lateral rim delimiting the support plate, which lateral rim preferably extends downwards relative to said support plate;
- an electric vibration motor fastened to the lower face of the support plate;
- an electric infrared emitting plate element being positioned above or on top of said support plate; and
- 10 - a cover plate of a polymeric material and adapted to cover at least the support plate and the electric infrared emitting plate element.

The inventor has surprisingly found that the combination of infra-red radiation with vibration directed to the foot of a patient with pre-tibial lacerations, result in a markedly
15 reduced healing time. When testing only one foot of a patient with pre-tibial lacerations on both shins, with the apparatus of the present invention, the healing time of the pre-tibial laceration was reduced with two weeks compared to the untreated foot. The same patient was at a later stage tested with only vibration, and inferior results was observed. The apparatus according to the present invention is also thought to prevent or alleviate
20 many vascular-related disorders in the feet and lower limbs, such as the shins.

The part of the cover plate covering the support plate and the electric infrared emitting plate element is adapted to receive and support a user's feet. The user is preferably seated on a chair while resting his or her feet on the cover plate. The apparatus vibrates
25 and emits infrared radiation at the same time. The vibrations are formed by an electric vibration motor, e.g. by two or three electric vibration motors. In order to provide stability to the apparatus, a chassis is incorporated. The chassis is preferably made from metal, such as steel or aluminum, but other materials such as reinforced polymeric materials may also be used. The chassis comprises a support plate, and a lateral rim delimiting
30 the support plate. The lateral rim preferably extends downwards relative to said support plate to function as a fastening plate for the cover plate and/or for the legs. In one or more embodiments, a part of each leg is formed from the lateral rim.

In one or more embodiments, the support plate is made from sheet metal with
35 embossing's to improve the rigidity.

The apparatus may further include a control module. The control module controls the speed of the electric vibration motor. The apparatus may additionally include a control panel, where the control panel allows a user to change one or more settings, such as the oscillation frequency, controlled by the control module. The apparatus may also
5 include a display, where the display is configured to show the current settings to a user.

In one or more embodiments, the electric vibration motor is configured for lateral vibration and/or oscillation of the support plate, and hence also the cover plate; i.e. the cover plate moves up and down (or in and out) contrary to a side to side movement.
10

In one or more embodiments, another electric vibration motor is configured for pivotal vibration and/or oscillation of the support plate.

In one or more embodiments, the electric vibration motor(s) is(are) a DC motor.
15

In one or more embodiments, the electric vibration motor(s) is(are) an AC motor.

The inventor has found that the electric vibration motor should preferably be an Eccentric Rotating Mass (ERM) vibration motor capable of operating with a power strong enough for the user's leg muscles to contract and relax, thereby inducing the muscle pump system. Apart from the power of the vibrations that the apparatus is vibrated with, the specific frequency is also important. The inventor has found that the electric vibration motor should preferably configured to operate at a power of at least 20 watts, and at a speed of at least 900 RPM, such as within the range of 900-3000 RPM.
20

In one or more embodiments, the electric vibration motor is configured to operate at a power of 20-100 watts, such as within the range of 25-95 watts, e.g. within the range of 30-80 watts, such as within the range of 35-75 watts, e.g. within the range of 40-70 watts, such as within the range of 45-65 watts, e.g. within the range of 50-60 watts. In one or more embodiments, the electric vibration motor is configured to operate at a
30 speed of 900-3000 RPM, such as within the range of 950-2950 RPM, e.g. as within the range of 1000-2900 RPM, such as within the range of 1050-2850 RPM, e.g. as within the range of 1100-2800 RPM, such as within the range of 1150-2750 RPM, e.g. as within the range of 1200-2700 RPM, such as within the range of 1250-2650 RPM, e.g. as within the range of 1300-2600 RPM, such as within the range of 1350-2550 RPM,
35 e.g. as within the range of 1400-2500 RPM, such as within the range of 1450-2450

RPM, e.g. as within the range of 1500-2400 RPM, such as within the range of 1550-2350 RPM, e.g. as within the range of 1600-2300 RPM, such as within the range of 1650-2250 RPM, e.g. as within the range of 1700-2200 RPM, such as within the range of 1750-2150 RPM, e.g. as within the range of 1800-2100 RPM, such as within the range of 1850-2050 RPM, e.g. as within the range of 1900-2000 RPM. Preferably, the electric vibration motor should preferably be configured to operate at a power of 20-35 watts, and at a speed of 1200-1500 RPM.

In one or more embodiments, the electric vibration motor is an Eccentric Rotating Mass vibration motor, or ERM, also known as a pager motor. The ERM motor is a DC motor with an offset (non-symmetric) mass attached to the shaft. As the ERM rotates, the centripetal force of the offset mass is asymmetric, resulting in a net centrifugal force, and this causes a displacement of the motor. With a high number of revolutions per minute, the motor is constantly being displaced and moved by these asymmetric forces. It is this repeated displacement that is perceived as a vibration. Many mechanical engineering textbooks discuss the characteristics of ERMs, as a 'rotating unbalance', and do so in a negative context. Often engineers are trying to minimize the source of vibration from rotating machinery, because it generates noise and causes excessive machine wear and fatigue. As a result, there is little literature on the theory of maximizing the amplitude of vibration in applications. The strength of vibration produced by the motor is affected by the mass of the eccentric weight, the distance between the eccentric mass and motor shaft, and the speed of rotation. The motor itself and what it is built into will also affect the equivalent values for stiffness of spring, the dampening characteristics, and mass of the ERM, which in turn will affect the level of vibration.

In one or more embodiments, the apparatus further comprises one or more springs supporting the chassis. Preferably, the springs are part of the apparatus' legs.

In one or more embodiments, the apparatus further comprises a plurality of legs connected to the chassis. In one or more embodiments each leg comprises a spring adapted for supporting the chassis, or alternatively, each leg consists of an elastomeric material, such as rubber. The feet may be of the suction cup type, or simply of rubber, to prevent the apparatus from moving along the surface, during use, on which the apparatus is resting.

In one or more embodiments, the lateral rim extends downwards relative to said support plate, and wherein the cover plate is mounted to said lateral rim.

5 In one or more embodiments, the cover forms a space in front of the chassis. This space may be used for fitting the control module that may be fastened to the chassis.

The electric infrared emitting plate element is preferably of a size capable of treating most of the foot sole surface area of the user, such as having a surface area of at least 300 square centimeters, e.g. within the range of 300-1600 cm², such as at least 400
10 cm², e.g. within the range of 400-1500 cm², such as at least 500 cm², e.g. within the range of 500-1400 cm², such as at least 600 cm², e.g. within the range of 700-1300 cm², such as at least 800 cm², e.g. within the range of 800-1200 cm², such as at least 900 cm², e.g. within the range of 900-1100 cm², such as at least 1000 cm².

15 In one or more embodiments, the electric infrared emitting plate element is able to emit infrared radiation at a wavelength of within 6-14 microns. The term mid infrared (MIR) generally covers the spectral region from approximately 3–50 microns according to ISO 20473. The inventor of the present invention has found that a narrower range (6-14
20 microns, such as within 7-13 microns, e.g. within 8-12 microns, such as within 9-11 microns, and preferably within 9-10 microns) of infrared radiation is suitable for the present purpose, as it is the wave length that is used in some infra-red saunas for therapeutic use.

In one or more embodiments, the electric infrared emitting plate element is emitting infrared waves at a frequency of within 6-14 microns, such as within 7-13 microns, e.g.
25 within 8-12 microns, such as within 9-11 microns, and preferably within 9-10 microns.

In one or more embodiments, the cover plate is made of either i) a thermoplastic material or polymer that transmits more than 30% of incident infrared radiation in the wavelength spectrum of 6-14 microns, or ii) a plate glass that transmits more than 30%
30 of incident infrared radiation in the wavelength spectrum of 6-14 microns. A cover plate of a traditional material, such as e.g. polyesters, and polyamides, is opaque to infrared waves in the 6-14-micron frequency range. Hence, specially selected polymeric compositions are preferably needed to obtain a rapid treatment by infrared waves.

Otherwise the cover plate will first have to be heated by the infrared waves, and then
35 subsequently act as an infrared transmitter itself. Thus, the cover plate material should

preferably transmit more than 30%, e.g. more than 40%, such as within 50-99%, e.g. within 55-95%, such as within 60-90%, e.g. within 65-85%, such as within 70-80% of the infrared waves at a frequency of within 6-14 microns, such as within 7-13 microns, e.g. within 8-12 microns, such as within 9-11 microns, and preferably within 9-10 microns.

5 Suitable examples of such material may be polyethylene, polypropylene, or mixtures thereof. The front cover plate is needed for two reasons. First, the user should not be able to touch the infrared emitting elements, and second, the infrared emitting elements should be cleaned between sessions to remove sweat, grease, and dirt that otherwise absorb or block the infrared waves at a frequency of within 6-14 microns.

10

The electric infrared emitting plate element comprises a carbon membrane. The carbon membrane may be made by coating a backing material, such as a metal or polymer plate or a textile, with a mixture of a binder and a carbon source, such as graphite, charcoal, carbon black in the form of fibers or powder. The binder should be suitable for use at temperatures of within 0-100 degrees Celsius. Suitable examples of carbon membranes may be found in US20110081135 and US6549809, hereby incorporated by reference. As a nonlimiting example, the electric infrared emitting plate element comprises electrodes on both ends, in contact with a carbon black layer. When the carbon black layer is energized through the electrodes, the entire carbon black layer heats up by resistance heating, thereby radiating far infrared rays.

15
20

The carbon source layer may be coated onto any suitable backing, e.g. a FR-4 plate. FR-4 is a composite material composed of woven fiberglass cloth with an epoxy resin binder that is flame resistant (self-extinguishing).

25

As another example, the electric infrared emitting plate element may comprise a frame, a thin layer, a grounding circuit board, a cloth layer and a second layer. The thin layer includes a carbon membrane and a printed circuit board. Two wires are used to connect the carbon membrane with a control module. The grounding circuit board includes a grounding layer, a circuit board, and a wire. The wire is used to connect the grounding circuit board with the ground. The grounding layer of the grounding circuit board may comprise a temperature regulating device, which can regulate the temperature of the electric infrared emitting plate element. The second layer may have a crisscross pattern, and a plurality of fixing devices, and is used to fixedly hold the thin layer, grounding circuit board, and cloth layer in the frame.

30

It should be noted that embodiments and features described in the context of one of the aspects of the present invention also apply to the other aspects of the invention.

Brief description of the figures

5 Figure 1 shows a side view of an apparatus in accordance with various embodiments of the invention, where the cover plate is made transparent;

Figure 2 shows a perspective view of an apparatus in accordance with various
embodiments of the invention;

10

Figure 3 shows a perspective view of an apparatus in accordance with various
embodiments of the invention, where the cover plate has been removed;

Figure 4 shows a perspective view of an apparatus in accordance with various
15 embodiments of the invention, where the cover plate and the electric infrared emitting
plate element have been removed; and

Figure 5 shows a bottom view of the apparatus as shown in Figure 4.

20 ***Detailed description of the invention***

Referring to Figure 1, the general scheme of the invention is shown. Figure 1 shows a
side view of an apparatus 100 in accordance with various embodiments of the invention,
where the cover plate is made transparent. The apparatus 100 comprises a chassis
110, an electric vibration motor 120, an electric infrared emitting plate element 130, a
25 cover plate 140, and a control module 160. Figure 2 shows a perspective view of the
apparatus, where the cover plate is not made transparent. The length of the apparatus
is 46 cm, and the width is 40 cm.

In order to provide stability to the apparatus 100, a chassis 110 is incorporated. The
30 chassis 110 is preferably made from metal, such as galvanized or stainless steel or
aluminum, but other materials such as reinforced polymeric materials may also be used.
The chassis 110 (Figure 3) comprises a support plate 112, and a lateral rim 114
delimiting the support plate 112. The lateral rim 114 extends downwards relative to the
support plate 112 to function as a fastening plate for the cover plate 140.

The apparatus vibrates and emits infrared radiation at the same time. The vibrations are formed by an electric vibration motor 120. The electric vibration motor 120 is fastened to the lower face 116 of the support plate 112.

5 Figure 3 shows a perspective view of an apparatus in accordance with various embodiments of the invention, where the cover plate has been removed to show the infrared emitting plate element 130. The electric infrared emitting plate element 130 is positioned on top of the support plate 112. The electric infrared emitting plate element 130 has a surface area of about 850 square centimeters.

10

The cover plate 140 is made of a polymeric material and adapted to cover the support plate 112 and the electric infrared emitting plate element 130. The polymeric material may be polyethylene or polypropylene.

15 The apparatus 100 includes a control module 160. The control module 160 controls the speed of the electric vibration motor 120. The control module is shown comprising a control panel that allows a user to change one or more settings, such as the oscillation frequency, controlled by the control module.

20 The apparatus 100 further comprises four springs 150 supporting the chassis 110.

Figure 4 shows a perspective view of an apparatus 100 in accordance with various embodiments of the invention, where the cover plate and the electric infrared emitting plate element have been removed. The support plate 112 is made from sheet metal with
25 two embossing's 113 to improve the rigidity.

Figure 5 shows a bottom view of the apparatus 100 as shown in Figure 4.

References

	100	Apparatus
	110	Chassis
	112	Support plate
5	113	Embossing
	114	Rim
	115	Upper face
	116	Lower face
	120	Vibration motor
10	130	Infrared emitting plate element
	140	Cover plate
	150	Spring
	160	Control module

Conclusies

1. Inrichting (100), omvattende:
 - een chassis (110) met een steunplaat (112) en een laterale rand (114) die de steunplaat (112) begrenst, waarbij de laterale rand (114) zich bij voorkeur naar beneden uitstrekt ten opzichte van die steunplaat (112);
 - een elektrische trilmotor (120) bevestigd aan de onderkant (116) van de steunplaat (112);
 - een elektrisch infrarood uitstralend plaalement (130) omvattende een koolstofmembraan en dat is gepositioneerd boven of bovenop de steunplaat (112); en
- 5
10 - een afdekplaat (140) van een polymeer materiaal en die is ingericht om ten minste de steunplaat (112) en het elektrische infrarood uitstralende plaalement (130) af te dekken.

2. Inrichting (100) volgens conclusie 1, verder omvattende een of meer veren (150) die het chassis (110) ondersteunen.
- 15
3. Inrichting (100) volgens conclusie 1, verder omvattende een veelheid van poten die zijn verbonden met het chassis en a) elk een veer (150) omvat die is ingericht om het chassis te ondersteunen, of b) elk uit een elastomeer materiaal, zoals rubber, bestaat.

- 20 4. Inrichting (100) volgens willekeurig welke conclusie 1 tot en met 3, waarbij de laterale rand (114) zich naar beneden uitstrekt ten opzichte van die steunplaat (112) en waarbij de afdekplaat (140) op die laterale rand (114) is gemonteerd.

5. Inrichting (100) volgens willekeurig welke conclusie 1 tot en met 4, waarbij het elektrische infrarood uitstralende plaalement (130) een oppervlakte heeft van ten minste 25 300 vierkante centimeter.

6. Inrichting (100) volgens willekeurig welke conclusie 1 tot en met 5, waarbij de elektrische trilmotor (120) is ingericht om te werken bij een vermogen van ten minste 20 30 watt en bij een snelheid van ten minste 900-300 tpm.

7. Inrichting (100) volgens willekeurig welke conclusie 1 tot en met 6, waarbij de steunplaat (112) is gemaakt van plaatmetaal met structuren (113) om de stijfheid te verbeteren.

8. Inrichting (100) volgens willekeurig welke conclusie 1 tot en met 7, waarbij de steunplaat (112) 1-20 graden is gekanteld ten opzichte van het oppervlak waarop de inrichting (100) rust en waarbij het gedeelte van de afdekplaat (140) dat de steunplaat (112) afdekt in
5 dezelfde mate is gekanteld.

9. Inrichting (100) volgens willekeurig welke conclusie 1 tot en met 7, waarbij het gedeelte van de afdekplaat (140) dat de steunplaat (112) afdekt 1-20 graden is gekanteld ten opzichte van het oppervlak waarop de inrichting (100) rust.
10

10. Inrichting (100) volgens willekeurig welke conclusie 1 tot en met 9, waarbij de afdekplaat (140) is gemaakt van of bestaat uit een thermoplastisch materiaal of polymeer, zoals polyethyleen of polypropyleen of mengsels daarvan.

1

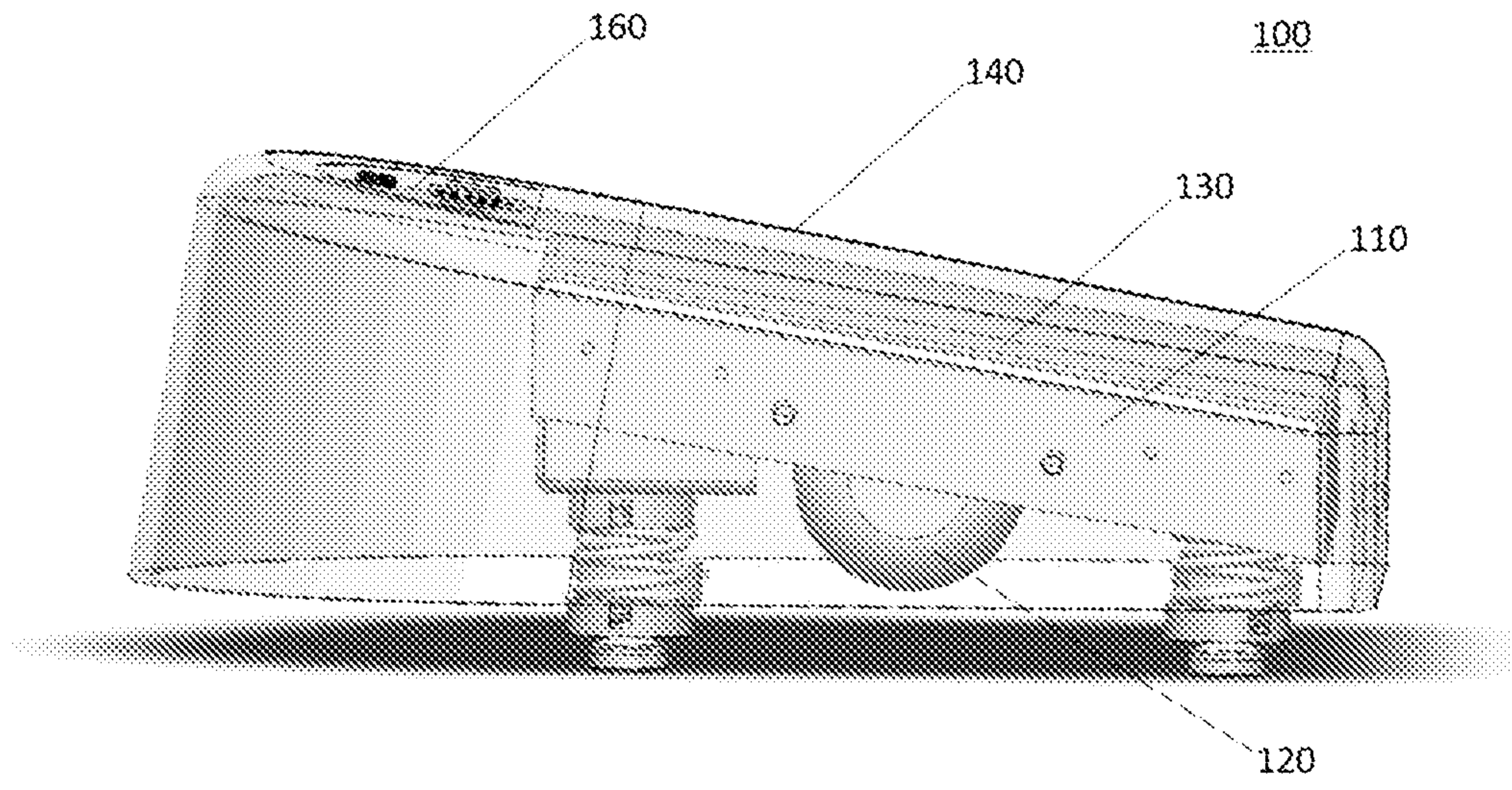

Fig. 1

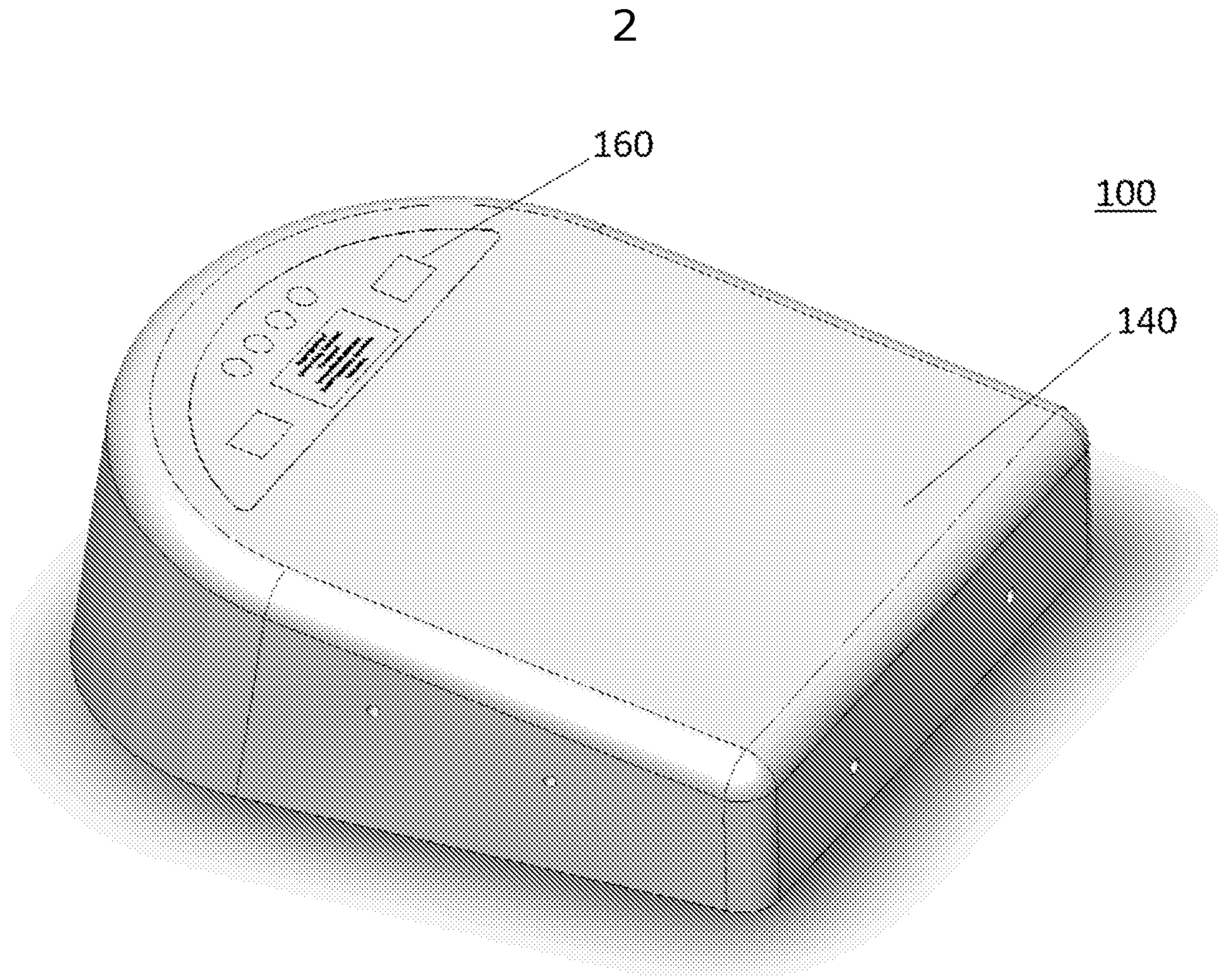

Fig. 2

3

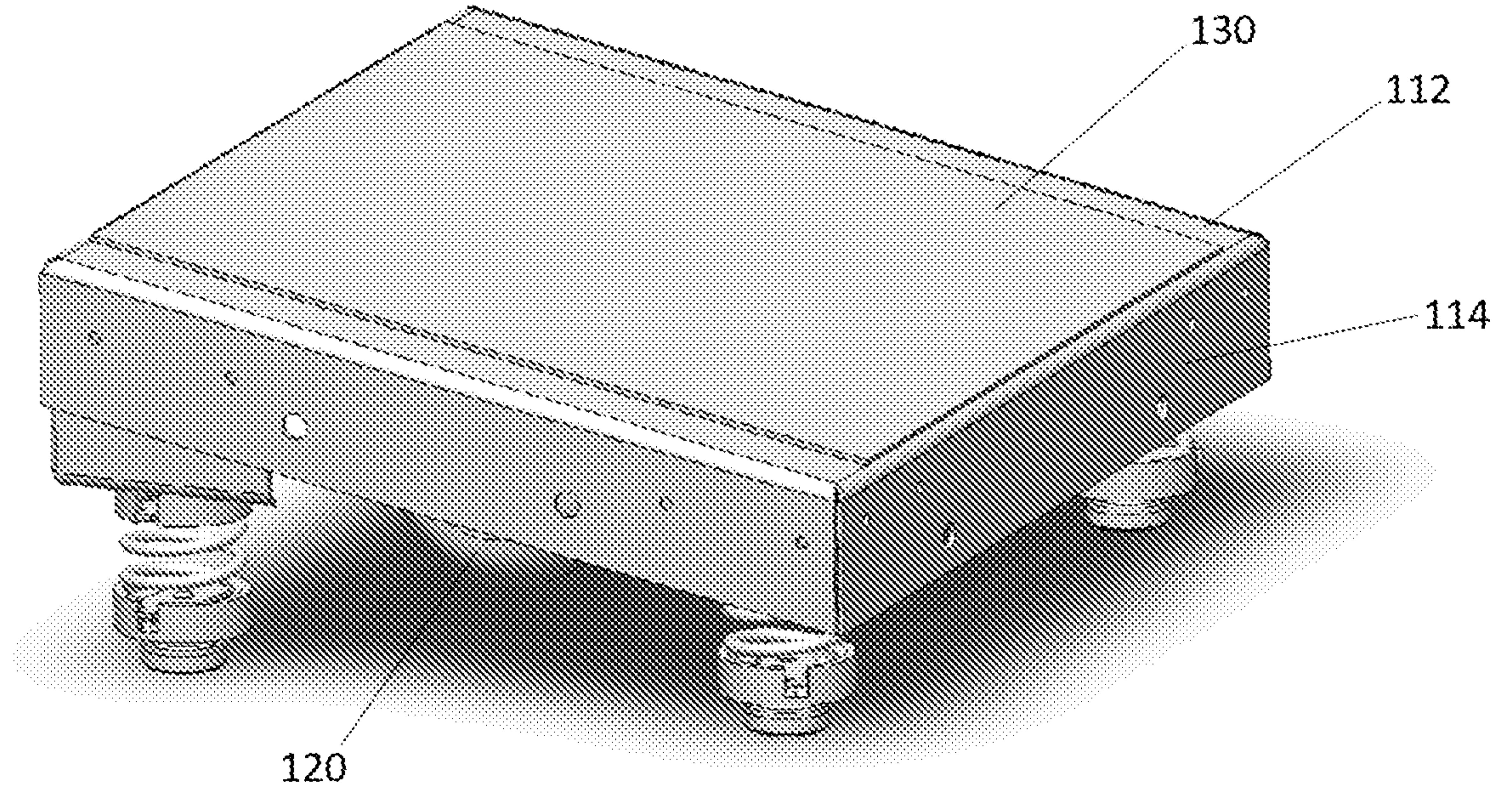

Fig. 3

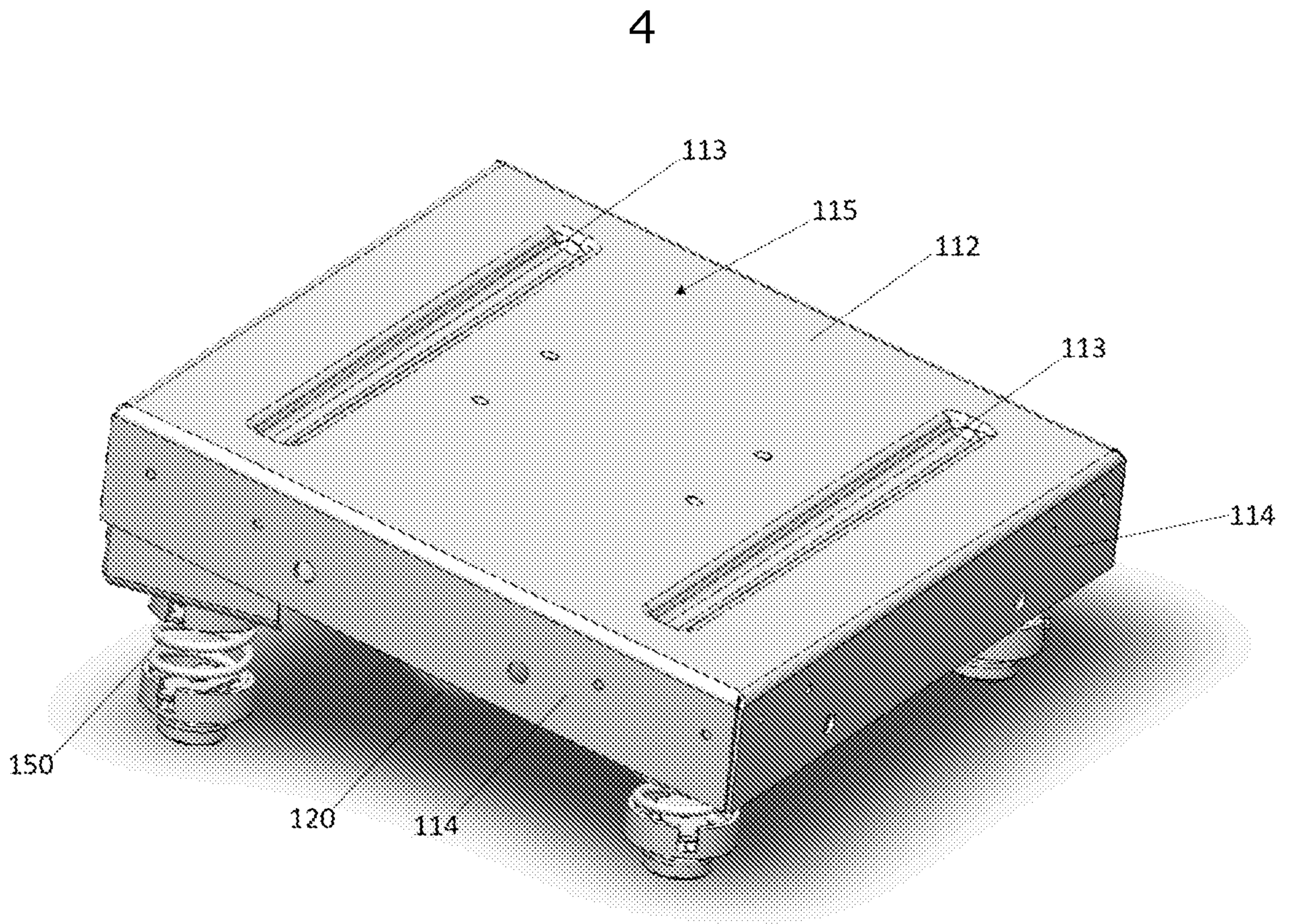

Fig. 4

5

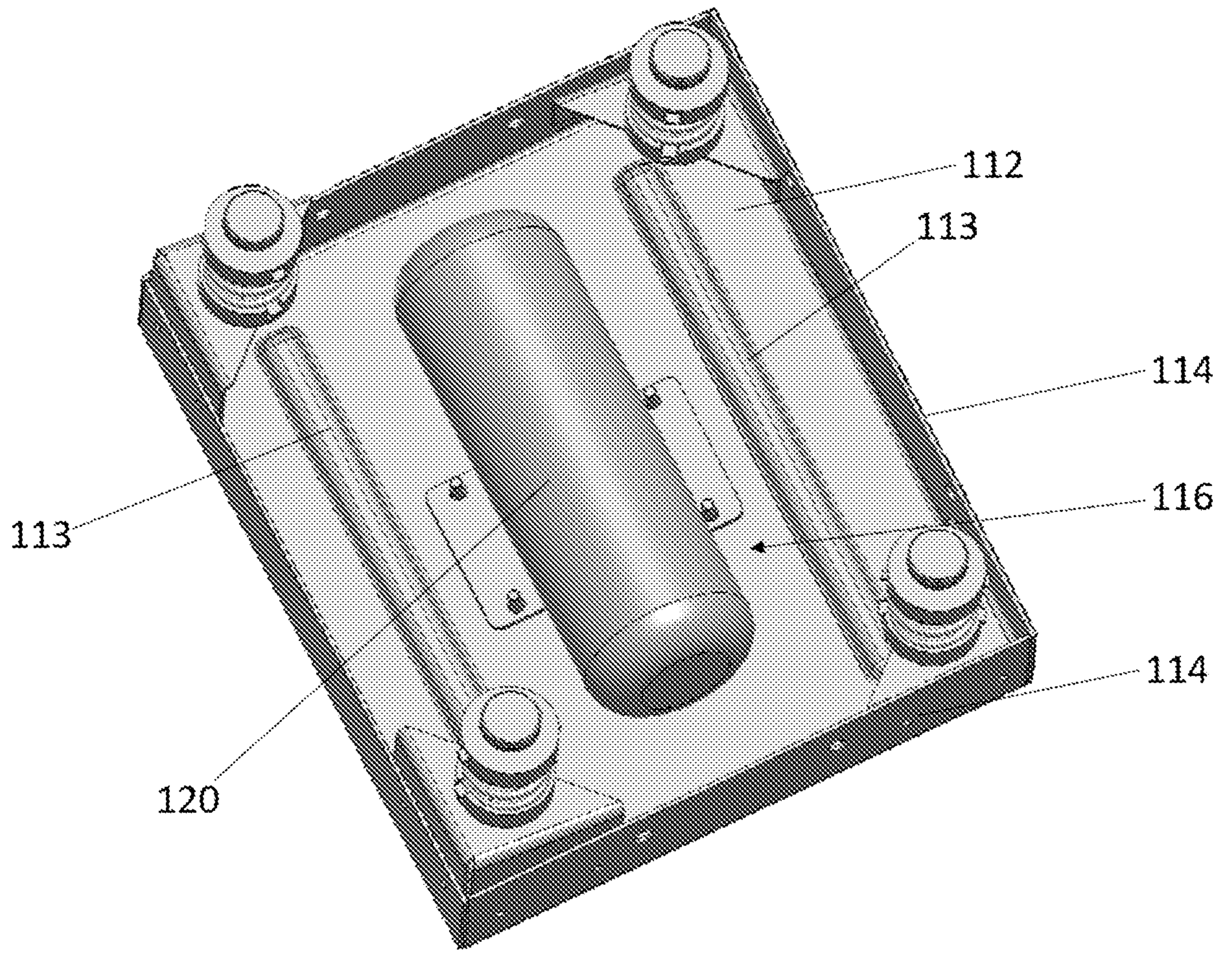

Fig. 5

SAMENWERKINGSVERDRAG (PCT)

RAPPORT BETREFFENDE NIEUWHEIDSONDERZOEK VAN INTERNATIONAAL TYPE

IDENTIFICATIE VAN DE NATIONALE AANVRAGE	KENMERK VAN DE AANVRAGER OF VAN DE GEMACHTIGDE P6091814NL
Nederlands aanvraag nr. 2024910	Indieningsdatum 14-02-2020
	Ingeroepen voorrangsdatum 27-02-2019
Aanvrager (Naam) Valdgård Holding ApS	
Datum van het verzoek voor een onderzoek van internationaal type 11-07-2020	Door de Instantie voor Internationaal Onderzoek aan het verzoek voor een onderzoek van internationaal type toegekend nr. SN76501
I. CLASSIFICATIE VAN HET ONDERWERP (bij toepassing van verschillende classificaties, alle classificatiesymbolen opgeven)	
Volgens de internationale classificatie (IPC) Zie onderzoeksrapport	
II. ONDERZOCHE GEBIEDEN VAN DE TECHNIEK	
Onderzochte minimumdocumentatie	
Classificatiesysteem	Classificatiesymbolen
IPC	Zie onderzoeksrapport
Onderzochte andere documentatie dan de minimum documentatie, voor zover dergelijke documenten in de onderzochte gebieden zijn opgenomen	
III. <input type="checkbox"/>	GEEN ONDERZOEK MOGELIJK VOOR BEPAALDE CONCLUSIES (opmerkingen op aanvullingsblad)
IV. <input type="checkbox"/>	GEBREK AAN EENHEID VAN UITVINDING (opmerkingen op aanvullingsblad)

**ONDERZOEKSRAPPORT BETREFFENDE HET
RESULTAAT VAN HET ONDERZOEK NAAR DE STAND
VAN DE TECHNIEK VAN HET INTERNATIONALE TYPE**

Nummer van het verzoek om een onderzoek naar
de stand van de techniek
NL 2024910

<p>A. CLASSIFICATIE VAN HET ONDERWERP INV. A61H23/02 A61H1/00 ADD.</p>		
<p>Volgens de Internationale Classificatie van octrooien (IPC) of zowel volgens de nationale classificatie als volgens de IPC.</p>		
<p>B. ONDERZOCHE GEBIEDEN VAN DE TECHNIEK</p>		
<p>Onderzochte minimum documentatie (classificatie gevolgd door classificatiesymbolen) A61H A61F</p>		
<p>Onderzochte andere documentatie dan de minimum documentatie, voor dergelijke documenten, voor zover dergelijke documenten in de onderzochte gebieden zijn opgenomen</p>		
<p>Tijdens het onderzoek geraadpleegde elektronische gegevensbestanden (naam van de gegevensbestanden en, waar uitvoerbaar, gebruikte trefwoorden) EPO-Internal, WPI Data</p>		
<p>C. VAN BELANG GEACHTE DOCUMENTEN</p>		
<p>Categorie °</p>	<p>Geciteerde documenten, eventueel met aanduiding van speciaal van belang zijnde passages</p>	<p>Van belang voor conclusie nr.</p>
X	<p>KR 2012 0002080 A (KIM WEON KI [KR]) 5 januari 2012 (2012-01-05)</p>	1,4-10
Y	<p>* alineas [0010] - [0014], [0051]; figuren 1-2c *</p>	2,3
Y	<p>----- US 4 086 921 A (GONZALES DAVID ET AL) 2 mei 1978 (1978-05-02) * conclusies 1-15; figuren 1-3 *</p>	1-10
Y	<p>----- WO 2014/113216 A2 (MARODYNE MEDICAL LLC [US]) 24 juli 2014 (2014-07-24) * alinea [0137]; conclusies; figuren *</p>	2,3
Y	<p>----- US 3 942 520 A (MCNAIR SAMUEL L) 9 maart 1976 (1976-03-09) * kolom 2, regel 2; figuren *</p>	3
	----- -/--	
<p><input checked="" type="checkbox"/> Verdere documenten worden vermeld in het vervolg van vak C. <input checked="" type="checkbox"/> Leden van dezelfde octrooifamilie zijn vermeld in een bijlage</p>		
<p>° Speciale categorieën van aangehaalde documenten</p> <p>"A" niet tot de categorie X of Y behorende literatuur die de stand van de techniek beschrijft</p> <p>"D" in de octrooiaanvraag vermeld</p> <p>"E" eerdere octrooi(aanvraag), gepubliceerd op of na de indieningsdatum, waarin dezelfde uitvinding wordt beschreven</p> <p>"L" om andere redenen vermelde literatuur</p> <p>"O" niet-schriftelijke stand van de techniek</p> <p>"P" tussen de voorrangdatum en de indieningsdatum gepubliceerde literatuur</p> <p>"T" na de indieningsdatum of de voorrangdatum gepubliceerde literatuur die niet bezwaard is voor de octrooiaanvraag, maar wordt vermeld ter verheldering van de theorie of het principe dat ten grondslag ligt aan de uitvinding</p> <p>"X" de conclusie wordt als niet nieuw of niet inventief beschouwd ten opzichte van deze literatuur</p> <p>"Y" de conclusie wordt als niet inventief beschouwd ten opzichte van de combinatie van deze literatuur met andere geciteerde literatuur van dezelfde categorie, waarbij de combinatie voor de vakman voor de hand liggend wordt geacht</p> <p>"&" lid van dezelfde octrooifamilie of overeenkomstige octrooipublicatie</p>		
<p>Datum waarop het onderzoek naar de stand van de techniek van internationaal type werd voltooid</p> <p style="text-align: center;">8 december 2020</p>		<p>Verzenddatum van het rapport van het onderzoek naar de stand van de techniek van internationaal type</p>
<p>Naam en adres van de instantie</p> <p>European Patent Office, P.B. 5818 Patentlaan 2 NL - 2280 HV Rijswijk Tel. (+31-70) 340-2040, Fax: (+31-70) 340-3016</p>		<p>De bevoegde ambtenaar</p> <p style="text-align: center;">Shmonin, Vladimir</p>

**ONDERZOEKSRAPPORT BETREFFENDE HET
RESULTAAT VAN HET ONDERZOEK NAAR DE STAND
VAN DE TECHNIEK VAN HET INTERNATIONALE TYPE**

Nummer van het verzoek om een onderzoek naar
de stand van de techniek
NL 2024910

C.(Vervolg). VAN BELANG GEACHTE DOCUMENTEN		
Categorie °	Geciteerde documenten, eventueel met aanduiding van speciaal van belang zijnde passages	Van belang voor conclusie nr.
Y	US 2012/172953 A1 (CHEN LU-ZHUO [CN] ET AL) 5 juli 2012 (2012-07-05) * conclusie 10; figuren * -----	1-10
Y	CN 2 500 300 Y (UNIV JILIN [CN]) 17 juli 2002 (2002-07-17) * conclusies 1-3; figuur 5 * -----	1-10
Y	CN 205 515 497 U (PENG SHENGHUA) 31 augustus 2016 (2016-08-31) * conclusies; figuren * -----	1-10

**ONDERZOEKSRAPPORT BETREFFENDE HET
RESULTAAT VAN HET ONDERZOEK NAAR DE STAND
VAN DE TECHNIEK VAN HET INTERNATIONALE TYPE**

Informatie over leden van dezelfde octrooifamilie

Nummer van het verzoek om een onderzoek naar
de stand van de techniek

NL 2024910

In het rapport genoemd octrooigeschrift	Datum van publicatie	Overeenkomend(e) geschrift(en)	Datum van publicatie
KR 20120002080	A	05-01-2012	GEEN

US 4086921	A	02-05-1978	GEEN

WO 2014113216	A2	24-07-2014	AU 2014207857 A1 09-07-2015
			AU 2018229446 A1 04-10-2018
			EP 2945592 A2 25-11-2015
			US 2015359702 A1 17-12-2015
			WO 2014113216 A2 24-07-2014

US 3942520	A	09-03-1976	GEEN

US 2012172953	A1	05-07-2012	CN 102038569 A 04-05-2011
			US 2012172953 A1 05-07-2012

CN 2500300	Y	17-07-2002	GEEN

CN 205515497	U	31-08-2016	GEEN

WRITTEN OPINION

File No. SN76501	Filing date (<i>day/month/year</i>) 14.02.2020	Priority date (<i>day/month/year</i>) 27.02.2019	Application No. NL2024910
International Patent Classification (IPC) INV. A61H23/02 A61H1/00			
Applicant Valdgård Holding ApS			

This opinion contains indications relating to the following items:

- Box No. I Basis of the opinion
- Box No. II Priority
- Box No. III Non-establishment of opinion with regard to novelty, inventive step and industrial applicability
- Box No. IV Lack of unity of invention
- Box No. V Reasoned statement with regard to novelty, inventive step or industrial applicability; citations and explanations supporting such statement
- Box No. VI Certain documents cited
- Box No. VII Certain defects in the application
- Box No. VIII Certain observations on the application

	Examiner Shmonin, Vladimir
--	-------------------------------

WRITTEN OPINION**Box No. I Basis of this opinion**

1. This opinion has been established on the basis of the latest set of claims filed before the start of the search.
2. With regard to any **nucleotide and/or amino acid sequence** disclosed in the application and necessary to the claimed invention, this opinion has been established on the basis of:
 - a. type of material:
 - a sequence listing
 - table(s) related to the sequence listing
 - b. format of material:
 - on paper
 - in electronic form
 - c. time of filing/furnishing:
 - contained in the application as filed.
 - filed together with the application in electronic form.
 - furnished subsequently for the purposes of search.
3. In addition, in the case that more than one version or copy of a sequence listing and/or table relating thereto has been filed or furnished, the required statements that the information in the subsequent or additional copies is identical to that in the application as filed or does not go beyond the application as filed, as appropriate, were furnished.
4. Additional comments:

Box No. V Reasoned statement with regard to novelty, inventive step or industrial applicability; citations and explanations supporting such statement

1. Statement

Novelty	Yes: Claims	2-4, 6, 8-10
	No: Claims	1, 5, 7
Inventive step	Yes: Claims	
	No: Claims	1-10
Industrial applicability	Yes: Claims	1-10
	No: Claims	

2. Citations and explanations

see separate sheet

Re Item V

Reasoned statement with regard to novelty, inventive step or industrial applicability; citations and explanations supporting such statement

Reference is made to the following documents:

- D1 KR 2012 0002080 A (KIM WEON KI [KR]) 5 januari 2012 (2012-01-05)
- D2 US 4 086 921 A (GONZALES DAVID ET AL) 2 mei 1978 (1978-05-02)
- D3 WO 2014/113216 A2 (MARODYNE MEDICAL LLC [US]) 24 juli 2014 (2014-07-24)
- D4 US 3 942 520 A (MCNAIR SAMUEL L) 9 maart 1976 (1976-03-09)
- D5 US 2012/172953 A1 (CHEN LU-ZHUO [CN] ET AL) 5 juli 2012 (2012-07-05)
- D6 CN 2 500 300 Y (UNIV JILIN [CN]) 17 juli 2002 (2002-07-17)
- D7 CN 205 515 497 U (PENG SHENGHUA) 31 augustus 2016 (2016-08-31)

INDEPENDENT CLAIM 1. LACK OF NOVELTY

The present application does not meet the criteria of patentability, because the subject-matter of claim 1 is not new.

The document **D1** (alinea's [0010] - [0014], [0051]; figuren 1-2c) discloses (the references in parentheses applying to this document):

Inrichting (fig.2a,2b), omvattende:

- een chassis (60,50) met een steunplaat (10,50,fig.1c) en een laterale rand (50,60) die de steunplaat (10,50,fig.1c) begrenst, waarbij de laterale rand (50,60) zich bij voorkeur naar beneden uitstrekt ten opzichte van die steunplaat (10,50,fig.1c);
- een elektrische trilmotor (70,76) bevestigd aan de onderkant (fig.2b) van de steunplaat (10,50,fig.1c);
- een elektrisch infrarood uitstralend plaalement (12) omvattende een koolstofmembraan (§14,§50) en dat is gepositioneerd boven of bovenop de steunplaat (10,50,fig.1c); en

- een afdekplaat (13-15,31) van een polymeer materiaal (§12,20) en die is ingericht om ten minste de steunplaat (10,50,fig.1c) en het elektrische infrarood uitstralende plaalement (12) af te dekken.

INDEPENDENT CLAIM 1. LACK OF INVENTIVE STEP

Document D2 (see passages cited in the Search Report) discloses device comprising all features of claim 1 except explicitly mentioning a feature "koolstofmembraan".

Documents D1, D5-D7 (see passages cited in the Search Report) describes similar devices and is provided with such heating elements comprising a "koolstofmembraan".

D2 discloses a heating element having a flat structure such that the skilled person would therefore consider to combine the teachings of D2 with the teaching of D1, or D5-D7 without application of an inventive skill and arrive to the subject-matter of claim 1 of the present application, especially as the advantages thus achieved can readily be foreseen.

DEPENDENT CLAIMS 2-10

Dependent claims **2-10** do not contain any features which, in combination with the features of any claim to which they refer, meet the requirements of novelty or inventive step, see documents **D1-D7** and the corresponding passages cited in the search report.

Lack of novelty of claims 5,7

The document **D1** (alineaas [0010] - [0014], [0051]; figuren 1-2c) discloses (the references in parentheses applying to this document) the subject-matter of **claims 5,7**: een oppervlakte van ten minste 300 vierkante centimeter (the size of two feet, fig.1), de steunplaat (10,50,fig.1c) is gemaakt van plaatmetaal (§55).

Lack of inventive step of claims 4,6,8-10

The additional subject-matter of **claims 4,6,8-10** is seen as comprising simple constructional measures in the field of feet massaging and warming devices.

D3 (fig.1) discloses a feature: een of meer veren (16), D4 (kolom 2, regel 2; figuren) discloses a feature: rubber, D2 (conclusies 1-15; figuren 1-3) discloses: de laterale rand (14) zich naar beneden uitstrekt ten opzichte van die steunplaat 38, de steunplaat 38 1-20 graden is gekanteld, de afdekplaat 14,50 is gemaakt van of bestaat uit een thermoplastisch materiaal of polymeer (*The outer covering 50 is the upholstery layer and can be a synthetic polymer composition material*).

Various combinations of dependent claims.

In view of the above, various combinations of isolated features from claims 2-10 do not provide a synergic effect, such that an aggregation of such features does not involve an inventive step but lies entirely within the customary practice followed by persons skilled

in the art. The documents cited in the Search Report (see citations and corresponding passages cited in the Search Report) can be combined to result in the devices according to the subject-matter of the dependent claims.