

(19) World Intellectual Property Organization
International Bureau



(43) International Publication Date
13 November 2008 (13.11.2008)

PCT

(10) International Publication Number
WO 2008/135902 A2

- (51) International Patent Classification:
H01L 51/52 (2006.01)
 - (21) International Application Number:
PCT/IB2008/051647
 - (22) International Filing Date: 29 April 2008 (29.04.2008)
 - (25) Filing Language: English
 - (26) Publication Language: English
 - (30) Priority Data:
07107367.0 2 May 2007 (02.05.2007) EP
 - (71) Applicant (for DE only): PHILIPS INTELLECTUAL PROPERTY & STANDARDS GMBH [DE/DE]; Lübeckertordamm 5, 20099 Hamburg (DE).
 - (71) Applicant (for all designated States except DE, US): KONINKLIJKE PHILIPS ELECTRONICS N.V. [NL/NL]; Groenewoudseweg 1, NL-5621 BA Eindhoven (NL).
 - (72) Inventors; and
 - (75) Inventors/Applicants (for US only): VERJANS, Conrad, W., A. [NL/NL]; c/o Prof. Holstlaan 6, NL-5656 AA Eindhoven (NL). HENTE, Dirk [DE/DE]; c/o Prof. Holstlaan 6, NL-5656 AA Eindhoven (NL).
 - (74) Agent: BEKKERS, Joost; Prof. Holstlaan 6, NL-5656 AA Eindhoven, (NL).
 - (81) Designated States (unless otherwise indicated, for every kind of national protection available): AE, AG, AL, AM, AO, AT, AU, AZ, BA, BB, BG, BH, BR, BW, BY, BZ, CA, CH, CN, CO, CR, CU, CZ, DE, DK, DM, DO, DZ, EC, EE, EG, ES, FI, GB, GD, GE, GH, GM, GT, HN, HR, HU, ID, IL, IN, IS, JP, KE, KG, KM, KN, KP, KR, KZ, LA, LC, LK, LR, LS, LT, LU, LY, MA, MD, ME, MG, MK, MN, MW, MX, MY, MZ, NA, NG, NI, NO, NZ, OM, PG, PH, PL, PT, RO, RS, RU, SC, SD, SE, SG, SK, SL, SM, SV, SY, TJ, TM, TN, TR, TT, TZ, UA, UG, US, UZ, VC, VN, ZA, ZM, ZW.
 - (84) Designated States (unless otherwise indicated, for every kind of regional protection available): ARIPO (BW, GH, GM, KE, LS, MW, MZ, NA, SD, SL, SZ, TZ, UG, ZM, ZW), Eurasian (AM, AZ, BY, KG, KZ, MD, RU, TJ, TM), European (AT, BE, BG, CH, CY, CZ, DE, DK, EE, ES, FI, FR, GB, GR, HR, HU, IE, IS, IT, LT, LU, LV, MC, MT, NL, NO, PL, PT, RO, SE, SI, SK, TR), OAPI (BF, BJ, CF, CG, CI, CM, GA, GN, GQ, GW, ML, MR, NE, SN, TD, TG).
- Published:
— without international search report and to be republished upon receipt of that report

(54) Title: METHOD FOR MANUFACTURING AN OLED DEVICE AND SUCH AN OLED DEVICE

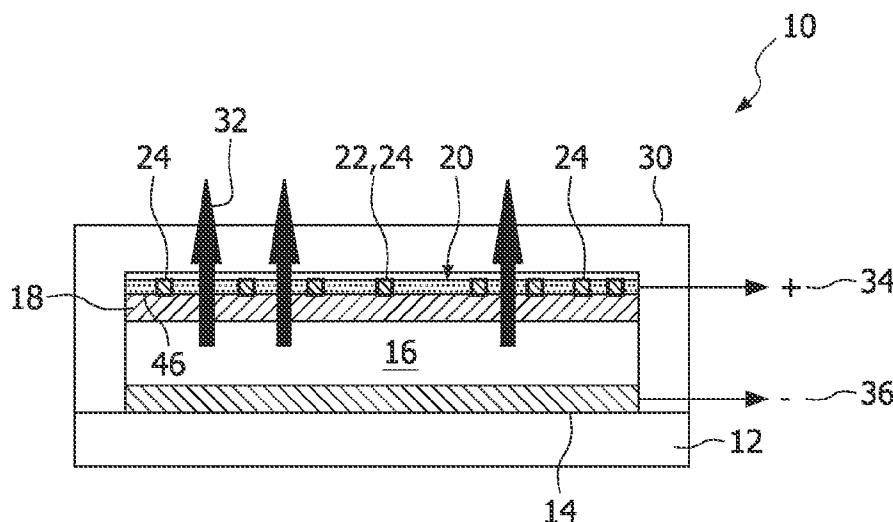

FIG. 1

(57) Abstract: The present invention relates to a method for manufacturing an OLED device, particularly a large area OLED device, comprising at least an emissive layer, a transparent conductor layer with a surface area and a grid unit having grid elements provided on the surface area of the conductor layer, comprising the steps of: modeling the current distribution of the OLED device without the grid unit, and designing the grid unit such that its grid elements are non-uniformly arranged on the conductor layer as to minimize inhomogeneities of the current distribution in the emissive layer. The invention also relates to such an OLED device.

WO 2008/135902 A2

METHOD FOR MANUFACTURING AN OLED DEVICE AND SUCH AN OLED DEVICE

5 FIELD OF THE INVENTION

The present invention relates to a method for manufacturing an OLED (organic light emitting diode) device, particularly a large area OLED device, comprising at least a transparent conductor layer with a surface area and a grid unit provided on the surface area of the conductor layer.

10 BACKGROUND OF THE INVENTION

Organic light emitting diode devices are generally known and gain increasing interest due to the advantages over liquid crystal displays or light emitting diodes. An organic light emitting diode is a special type of light emitting diode in which the emissive layer comprises a thin film of certain organic compounds. The emissive
15 electroluminescent layer can include a polymeric substance that allows the deposition of very suitable organic compounds, for example, in rows or columns on a flat carrier by using a simple "printing" method to create a matrix of pixels which can emit different colored light.

The emissive layer, which itself can consist of stapled layers, is
20 sandwiched between two electrode layers, one of which being transparent as to allow light passing through. The transparent electrode layer, which is also called conductor layer is often made of indium-tin-oxide which is transparent and conductive. However, the conductivity of this material is not comparable to that of for example metal. This poor conductivity does not play a role in OLED devices having small surface areas.
25 However, when increasing the surface area of the OLED device, the poor conductivity becomes a major issue which is addressed by providing low ohmic metal lines on the conductor layer for shunting. The low ohmic metal lines are arranged generally in form of horizontal and vertical lines defining grid elements of a uniform grid. In the context of the present invention grid element means any kind of a low ohmic element provided on

the conductor layer for shunting purposes.

Although OLED devices using such grids can get a larger homogeneous area and hence a more uniform light radiation, the presently used solutions are limited with respect to a further increase of the surface area of OLED devices.

5 SUMMARY OF THE INVENTION

Therefore, it is an object of the present invention to provide a method for manufacturing an OLED device, particularly a large area OLED device, which allows to design homogeneous OLED devices.

10 This object is solved by a method as mentioned above, comprising the steps of:

- modeling the current distribution of the OLED device without the grid unit, and
- designing the grid unit such that its grid elements are non-uniformly arranged on the conductor layer as to minimize inhomogeneities of the current distribution in the emissive layer.

15 In other words, the idea of the present invention is to use a grid unit design which is adapted to the current distribution of the OLED device, particularly the emissive layer, so that the combination of the emissive layer, conductor layer and the grid unit achieves a current distribution in the emissive layer which is more or less homogeneous. Hence, the grid unit at least partially compensates for a non-uniform
20 current distribution without grid unit.

The inventive solution achieves an OLED device which allows large surface areas for the emissive and transparent conductor layers without suffering from non-uniform light radiation.

25 Contrary to the prior art solutions which use uniform grids of horizontal and vertical lines, the grids manufactured according to the inventive method may be non-uniform if this design is required by the inhomogeneities of the current distribution in the OLED device (without grid unit), particularly in the emissive layer.

30 In a preferred embodiment, the grid unit is provided as metallic repetitive grid elements, for example in form of line elements, triangle elements, hexagonal elements, rectangular elements etc. The grid elements are preferably provided as low ohmic elements and are electrically coupled with each other.

More preferably, the grid unit is provided as a plurality of grid lines arranged parallel to each other with distances therebetween which are determined to obtain the desired current distribution. Moreover the grid lines may also have different widths and/or thicknesses.

5 In other words, the current distribution of the OLED device, particularly in the emissive layer, may be adjusted by selecting the distance between adjacent lines and/or the structure of each line, namely its width and/or thickness.

In a further preferred embodiment, an outermost grid line is placed a distance from the edge of the conductor layer, the distance being selected to accurately
10 control the in-coupling of the current into the conductor layer.

In a further preferred embodiment, the step of modeling comprises calculating the current distribution.

By calculating the current distribution of the OLED device (without grid unit), particularly in the emissive layer, the grid unit can be designed more accurately
15 compared to the step of modeling.

The object of the present invention is also solved by a large area OLED device comprising at least an emissive layer, a transparent conductor layer with a surface area, and a grid unit with grid elements provided on the surface area of the conductor layer, said emissive layer having a predetermined current distribution, wherein said grid
20 elements of said grid unit are arranged on the conductor layer non-uniformly as to minimize inhomogeneities of current distribution in the emissive layer.

This inventive OLED device has the advantage that a larger homogeneous area with respect to the transparent conductor layer is achievable. The inhomogeneities of large area OLED devices are minimized by the inventive grid unit and its non-
25 uniformly arranged grid elements so that the light radiation is homogeneous over the whole surface area of the transparent conductor layer.

Due to the fact that large area OLED devices with their emissive layers and conductor layers have in general non-uniform current distributions (without a grid unit), the grid unit is also non-uniform compared to the grids of prior art solutions which
30 use vertical and horizontal lines uniformly arranged.

It is preferred that the grid unit comprises a plurality of grid elements

electrically coupled with each other and distributed across the surface area. The grid elements are generally low ohmic elements, for example metallic lines, triangles, rectangles, hexagons or any other two-dimensional structures for shunting purposes. Of course, the grid unit may comprise grid elements of different structures, like a
5 combination of lines and rectangles.

Further, the grid elements of the grid unit may have any chaotic structure and for example, do not need to be continuous. Further, the structure of the grid elements with respect to width and/or thickness may be different, and hence non-uniform.

10 Further features and advantages can be taken from the following description and the enclosed drawings.

It is to be understood that features mentioned above and those yet to be explained below can be used not only in the respective combinations indicated, but also in other combinations or in isolation, without leaving the scope of the present invention.

15 One embodiment of the invention is shown in the drawings and will be explained in more detail in the description below with reference to same. In the drawings:

BRIEF DESCRIPTION OF THE DRAWINGS

In the drawings

20

Figure 1 shows a schematic side view of an OLED device according to the present invention; and

25 Figure 2 is a schematic plan view of an OLED device according to the present invention.

DETAILED DESCRIPTION OF EMBODIMENTS

30 In Figure 1, an organic light emitting diode device (OLED) is schematically shown and indicated with reference numeral 10. It is to be noted that the structure of the illustrated OLED device 10 only serves to describe the invention.

Therefore, the illustrated structure is not a detailed presentation of an OLED and hence does not comprise all elements necessary for implementing an OLED device.

Generally, an OLED device 10 comprises a substrate 12 which carries a cathode layer 14, an emissive layer 16, which itself can consist of stapled layers, and an conductor layer 18. The conductor layer 18 is made of a conductive transparent material so that light generated within the emissive layer may pass through the conductor layer. The cathode layer 14 and the transparent conductor layer 18 serve as electrodes which are coupled with the negative and positive terminals 36, 34, respectively, of a driver unit or a power supply.

10 The transparent conductor layer 18 comprises a transparent conductive oxide, such as indium-tin-oxide (ITO), the conductivity of this layer being generally adequate to produce the necessary light emissions to illuminate small OLEDs but the conductivity is not sufficient to produce the necessary current to illuminate a large area OLED.

15 Therefore, on the conductor layer 18 a grid unit 20 is provided. The grid unit 20 comprises a plurality of grid elements 22, which are low ohmic shunting elements and are distributed over a surface area 46 of the conductor layer 18. As shown in Figure 2, the grid unit 20 comprises grid elements 22 in form of metallic lines 24. The metallic lines 24 having a good conductivity are used to shunt the transparent conductor which
20 itself has a poor conductivity.

The grid elements are distributed over the surface area 46 of the conductor layer 18 according to a predetermined pattern which will be described below.

In the embodiment shown in Figure 2, the metallic lines 24 are placed parallel to each other on the conductor layer 18, wherein the distance d between adjacent
25 lines 24 decreases from the left side to the right side of Figure 2. In other words, the distance between the left outermost lines 24, which is indicated with d_1 , is greater than the distance d_2 of the right outermost lines 24.

Figure 2 also shows that all lines 24 are electrically coupled with an edge portion 21 of the grid unit.

30 Further, it is shown that there is a gap 42 between the edge of the conductor layer 42 on the right hand side and the first metallic line 24 from the right

side. This gap between the transparent conductor layer and the line 24 allows to regulate accurately the in-coupling of the current into the conductor layer 18.

As already mentioned before, the form and pattern of the grid elements 22 is designed on the basis of the current distribution characteristic of the OLED device, particularly its emissive layer 16, without a grid unit.

That is, the emissive layer 16 with the conductor layer 18 has a certain current distribution (without the grid unit 20 coupled thereto) which is in general non-uniform for large surface areas.

In order to determine the pattern of the grid elements 22, the current distribution of the OLED device, particularly the emissive layer 16, without a grid unit is theoretically modelled or practically calculated. The grid unit with its grid elements is then designed such that the inhomogeneities of the current distribution are minimized by the grid elements.

When the conductor layer 18 and the grid unit 20 are then combined, the current distribution in the emissive layer 16 is homogeneous and uniform with the result that the light produced in the emissive layer 16 is also homogeneous across the surface area.

The grid elements are hence used to minimize inhomogeneities of the current distribution in the large area emissive layer as to achieve a uniform light production. It is to be noted that the grid elements shown in Figure 2 are just illustrative examples rather than limiting the scope of the invention. The grid elements may also be provided as triangle elements, rectangular elements, hexagonal elements or any combination thereof. Further, the grid elements may have different widths and/or thicknesses.

Further, the grid elements may be continuous or non-continuous. The grid elements may have any chaotic structure only following the object to minimize inhomogeneities of current distribution in the emissive layer 16.

OLED devices having a grid unit as defined above may be used in general lighting, furniture, lighting for public spaces, city beautification, ambient lighting, etc. The OLED device according to the present invention is of particular interest for large area OLED devices.

CLAIMS:

5

1. Method for manufacturing an OLED device, particularly a large area OLED device, comprising at least an emissive layer, a transparent conductor layer with a surface area and a grid unit having grid elements provided on the surface area of the conductor layer, comprising the steps of:

- 10 - modeling the current distribution of the OLED device without the grid unit, and
 - designing the grid unit such that its grid elements are non-uniformly arranged on the conductor layer as to minimize inhomogeneities of the current distribution in the emissive layer.

15 2. Method of claim 1, wherein the grid unit is provided as metallic repetitive grid elements.

3. Method of claim 2, wherein said grid elements are selected from the group comprising line elements, triangle elements, hexagonal elements.

20

4. Method of claim 2 or 3, wherein said grid elements are provided as low ohmic elements and are electrically coupled with each other.

5. Method of claim 1, wherein said grid unit is provided as a plurality of grid
25 lines arranged parallel to each other with distances therebetween which are determined to minimize inhomogeneities of the current distribution.

6. Method of claim 5, wherein an outermost grid line is placed a distance
30 from the edge of the conductor layer, the distance being selected to accurately control the in-coupling of the current into the conductor.

7. Method of any of claims 1 to 6, wherein the step of modeling comprises calculating the current distribution.

8. Large area OLED device, comprising at least an emissive layer (16), a transparent conductor layer (18) with a surface area (46), and a grid unit (20) with grid elements (24) provided on the surface area (46) of the conductor layer (18), said emissive layer having a predetermined current distribution, wherein said grid elements (24) of the grid unit (20) are arranged on the conductor layer non-uniformly as to minimize inhomogeneities of current distribution in the emissive layer.

10

9. OLED device of claim 7, wherein said grid unit (20) comprises a plurality of grid elements (22) electrically coupled with each other and distributed across the surface area.

15 10. OLED device of claim 9, wherein said grid elements (22) are metallic lines (24), triangles, rectangles, hexagons or any other two-dimensional structure.

11. OLED device of claim 10, wherein said grid elements are lines (24) with different width and/or thickness.

20

1/1

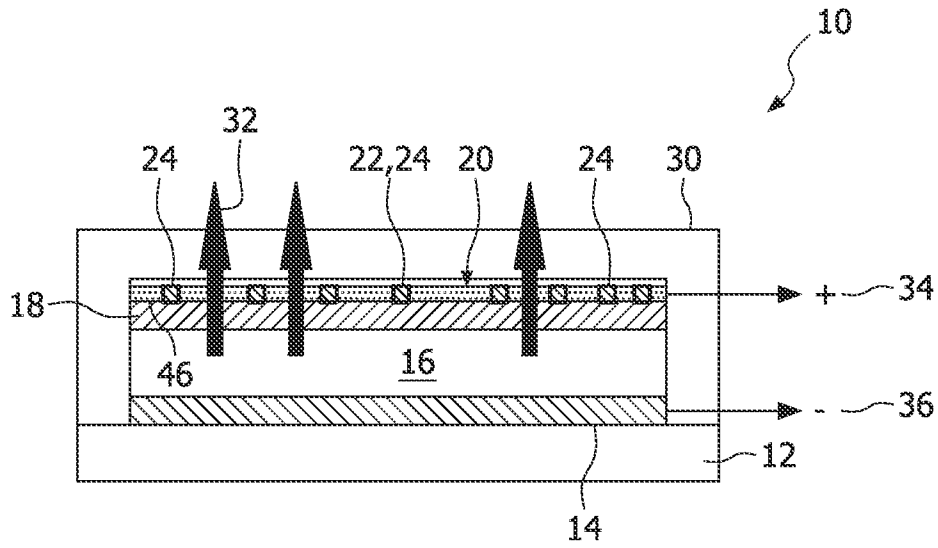

FIG. 1

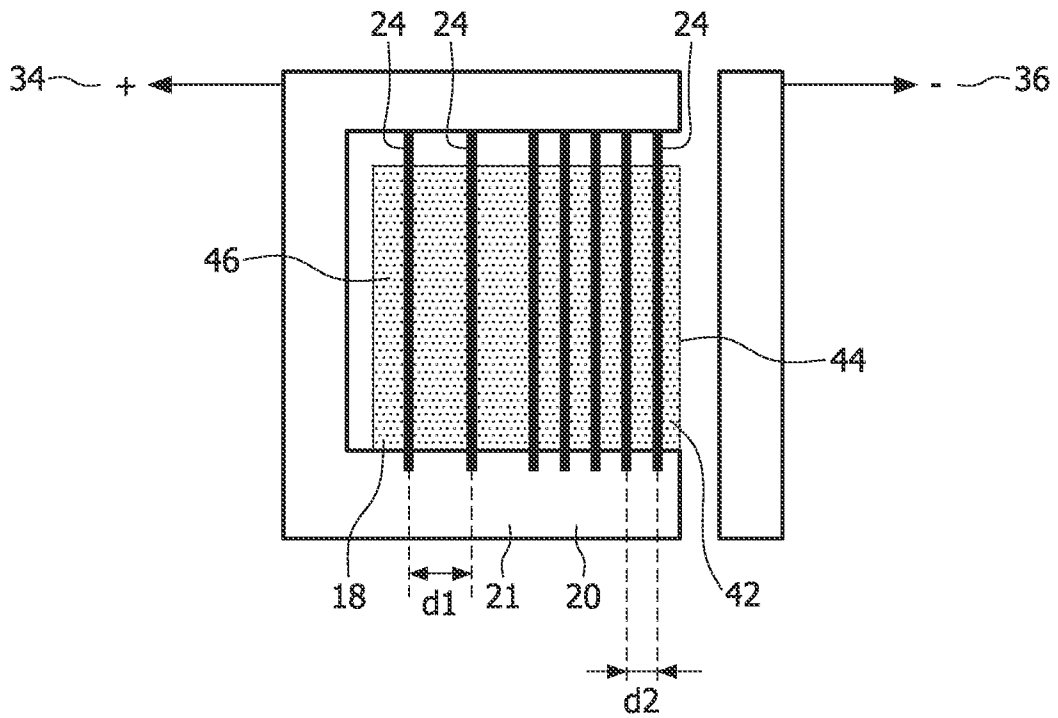

FIG. 2