

[72] **Inventors** Alfred Hesse;
Karl-Heinz Rosing, Wilhelmshaven,
Germany
[21] **Appl. No.** 775,003
[22] **Filed** Nov. 12, 1968
[45] **Patented** Mar. 2, 1971
[73] **Assignee** Olympia Werke A G
Wilhelmshaven, Germany
[32] **Priority** Nov. 25, 1967
[33] **Germany**
[31] O12903

[50] **Field of Search**..... 242/55,
67.1, 67.2, 75.2, 67.3, 76; 197/133, 180, 187

[56] **References Cited**
UNITED STATES PATENTS
2,633,968 4/1953 Lippert..... 197/133
2,780,165 2/1957 Kuhn..... 197/133X
Primary Examiner—George F. Mautz
Attorney—Michael S. Striker

[54] **PAPER GUIDING ARRANGEMENT FOR A BUSINESS MACHINE**
10 Claims, 2 Drawing Figs.

[52] **U.S. Cl.**..... 242/55,
197/133
[51] **Int. Cl.**..... B41j 15/04,
B65h 19/00

ABSTRACT: A paper roll supplies a paper band through an inlet opening in the housing of a business machine to a platen which transports the paper band back towards the top of the paper roll. When the diameter of the paper roll is small, the paper band is curved and tends to reenter the inlet opening which is prevented by a closure means mounted on the carrier of the paper roll and substantially closing the inlet opening when the carrier is displaced due to the reduction of the diameter of the paper roll.

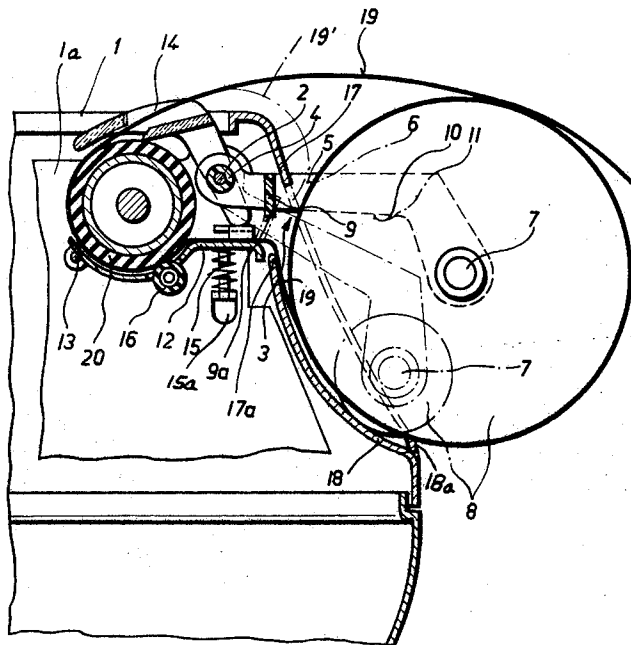
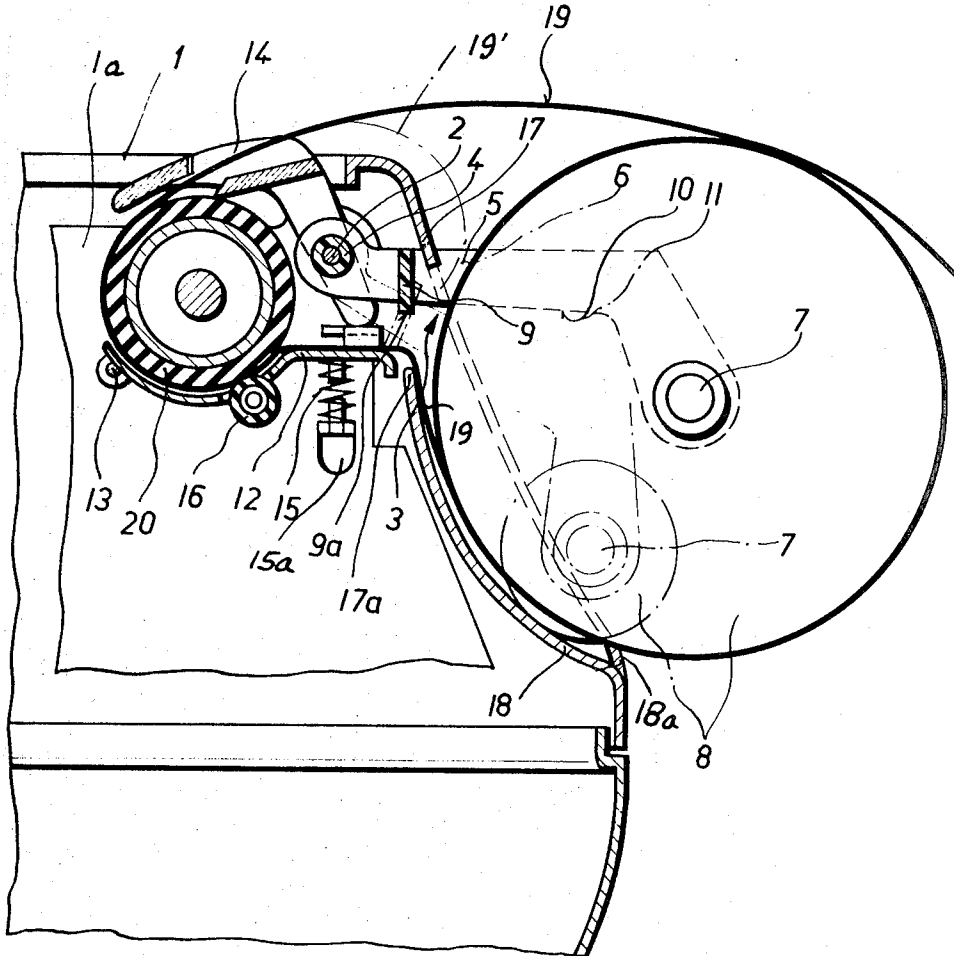

FIG. 1



INVENTORS ALFRED HESSE
KARL-HEINZ ROSING
BY: *Max S. Stricker*
ATTORNEY

PAPER GUIDING ARRANGEMENT FOR A BUSINESS MACHINE

BACKGROUND OF THE INVENTION

It is known to support paper roll resting on a housing wall on a pivoted carrier which moves downward as the diameter of the paper roll is decreased by supplying a paper band through an inlet opening of the housing to a platen which transports the paper band back towards and over the top of the paper roll.

However, it has been found that after the diameter of the paper roll is reduced, the paper band supplied by the same is sharply curved and therefore has a tendency to reenter the inlet opening and to be wound up on the platen which detrimentally influences the appearance of imprints on the paper band, and further requires unwinding of the woundup paper band from the platen.

SUMMARY OF THE INVENTION

It is one object of the invention to overcome this disadvantage of known paper guiding arrangements, and to provide a paper guiding arrangement preventing winding up of imprinted paper band on the platen of a business machine.

Another object of the invention is to provide a paper guiding arrangement in which a paper band supplied by a paper roll passes through an inlet opening in the housing, over a platen, and back towards the paper roll without reentering the inlet opening.

Another object of the invention is to provide means for automatically covering the inlet opening of the housing when the diameter of the paper roll has been reduced so that a paper band unwound from the paper roll can still enter through an inlet opening in the housing, while the free end of the paper band is prevented from entering the inlet opening.

Another object of the invention is to improve a known paper guiding arrangement by novel and unobvious structure of great simplicity serving the purpose of preventing a malfunction frequently occurring when the diameter of the paper roll is reduced.

With these objects in view, the carrier of the paper roll is provided with a closure means which covers the inlet opening through which the paper band passes to such an extent that the paper band can still be supplied to the platen, but cannot reenter the inlet opening after having passed around the platen.

One embodiment of the invention comprises a platen mounted in a housing having an inlet opening, carrier means for rotatably supporting a paper roll in a position resting on the housing and being mounted from movement between a first position in which the carrier means is held by a paper roll having a great diameter, and a second position in which the carrier means is held by a paper roll having a small diameter, and resting on the housing, and a closure means connected or fixedly secured to the carrier means for movement with the same and substantially uncovering, and substantially covering, the inlet opening in the first and second positions, respectively, of the carrier means.

The arrangement is such that the paper band curved to a small diameter on a paper roll having a small diameter cannot reenter into the inlet opening after having passed about the platen.

When the inlet opening of the housing is substantially covered by the closure means, the same rests on the supplied paper band and on a paper guide supporting the paper band.

In the preferred embodiment of the invention, the carrier means includes two arms located on opposite sides of the paper roll and having journals projecting into a center opening of the same so that the paper roll is supported for turning movement on the carrier means. The closure means is preferably a bar fixedly secured to the arms and extending between the same so that the closure bar moves with the carrier means whereas the diameter of the paper roll is progressively reduced due to the supply of the paper band to the platen.

A particularly inexpensive and simple construction is obtained when the carrier means and closure bar together form an integral body, which is advantageously molded of a thermoplastic synthetic material.

The novel features which are considered as characteristic for the invention are set forth in particular in the appended claims. The invention itself, however, both as to its construction and its method of operation, together with additional objects and advantages thereof, will be best understood from the following description of specific embodiments when read in connection with the accompanying drawing.

BRIEF DESCRIPTION OF THE DRAWING

FIG. 1 is a fragmentary vertical sectional view illustrating an embodiment of the invention; and

FIG. 2 is a fragmentary perspective view illustrating the rear portion of a business machine provided with embodiment of the invention shown in FIG. 1.

DESCRIPTION OF THE PREFERRED EMBODIMENTS

Referring now to the drawings, the housing 1 of the business machine includes vertical supporting walls 1a carrying a shaft 2 on which a carrier 3 for a paper roll 8 is mounted for angular movement about the axis of shaft 2. Carrier 3 includes a hollow sleeve 4 turnable on shaft 2 and a pair of arms 5 and 6 having journal portions 7 projecting into a central opening in paper roll 8 and supporting the same for turning movement. A closure bar 9 is secured to the arms 5 and 6 and extends between the same so that turning of carrier 3 about shaft 2 will cause up and down movement of closure bar 9. The lower edge 9a of closure bar 9 projects downward below the lower edges 10 and 11 of the arms 5 and 6.

It is advantageous to construct sleeve 4, arms 5 and 6, journal 7, and closure bar 9 as an integral body consisting of thermoplastic synthetic material.

As best seen in FIG. 1, the lower peripheral portion of paper roll 8 rests on a wall portion 18a of housing 1 when the roll still has a great diameter, as shown in solid lines, but when the diameter of the roll has been reduced, the lower portion of the roll rests on a curved wall portion 18, as shown in chain lines. As the diameter of the paper roll 8 is reduced, journals 7 move downward, and carrier 3 pivots downward about shaft 2 from a first higher position to a second lower position.

The closure bar 9 is located within the housing 1 adjacent an inlet opening which is formed between the edges of a pair of housing wall portions 17 and 17a.

A paper guide 12 is mounted for angular movement about a stationary shaft 13 supported on housing walls 1a. A pressure roller 16 is mounted for turning movement on paper guide 12 and cooperates with a cylindrical conventional platen 20 mounted for turning movement on housing walls 1a. The paper band 19 is guided from the lower peripheral portion of paper roll 8 through the inlet opening between wall portions 17 and 17a, over the top of paper guide 12, between platen 20 and pressure roller 16, and about platen 20 to pass between the same and a paper holder 14 by which the paper band 19 is guided toward and over the top of a full paper roll 18. Paper holder 14 is mounted for angular movement on shaft 2 and has a portion abutting a portion of paper guide 12. A pressure spring 15 urges paper guide 12 to turn in counterclockwise direction about shaft 13 so that the pressure roller 16 resiliently engages platen 20. The pressure of spring 15 can be adjusted to operation of manual adjusting means 15a. Spring 15 also acts through paper guide 12 to bias paper holder 14 in counterclockwise direction into engagement with paper band 19 on platen 20. When paper holder 14 is manually turned in clockwise direction about shaft 2, and away from platen 20, pressure roller 16 is also moved away from platen 20 and paper band 19 can be freely moved about the platen.

When a full paper roll 8 having a great diameter is placed on the journals 7, carrier 3 is raised to a position determined by the diameter of the paper roll whose lower peripheral portion rests on the housing. Paper band 19 unwound from roll 18 is

inserted into the housing through the space between wall portion 17a and the lower edge 9a of closure bar 9, and is placed on the top surface of paper guide 12, and inserted between pressure roller or pressure rollers 16 and platen 20. When the platen is turned in clockwise direction, the inserted paper band 19 is transported about the platen and guided by the paper holder 14 toward the rear of the machine, and since paper band 19 is only slightly curved due to the large diameter of the new full paper roll 8, it passes over the top surface of the full paper roll 8 without disturbing the further unwinding of the paper roll. Finally, a portion of a paper band 19 is torn off.

However, when the diameter of the paper roll 8 has been substantially reduced, the paper band is unwound therefrom in a sharply curved condition which is not improved by the platen which also has a small diameter. Consequently, the paper band 19', shown in chain lines, will not pass over the top of paper roll 8, but will reenter the inlet opening of the housing under the wall portion 17, as shown in chain lines in the upper portion of FIG. 1. If paper band 19' were permitted to continue its movement, its leading edge would be caught between pressure roller 16 and platen 20 and wound in repeated turns onto the platen.

This malfunction is prevented by the construction of the present invention since the closure bar 9 moves downward with carrier 3, and more specifically with arms 5 and 6 as the diameter of paper roll 8 is progressively reduced. When the diameter of paper roll 8 is so small that the unwound paper band 19' has a curvature causing reentry into the housing, carrier 3 is in the lower position shown in chain lines in FIG. 1, and the lower edge 9a of closure bar 9 rests on the unwound paper band and through the same on the paper guide 12 as shown in chain lines in FIG. 1. While the unwound paper band can enter between edge 9a and paper guide 12, the curved free leading end portion 19' cannot assume a position located on the paper guide 12 or between pressure roller 16 and platen 20, since it is blocked by closure bar 9 in the lower position shown in chain lines in FIG. 1.

Spring 15 is adjusted to provide sufficient pressure so that it cannot be compressed by the weight of carrier 3 with closure bar 9.

The closure bar 9 of the invention does not prevent the use of a new paper roll of small diameter. It is only necessary to slightly raise a small paper roll together with closure bar 9 so that carrier 3 and closure bar 9 assume the higher position as shown in FIG. 1, whereupon the paper band can be unwound from the lower portion of the small paper roll and inserted between the lower edge 9a of closure bar 9 and paper guide 12.

The term "closure bar" is used in the present application in a descriptive manner, and it will be understood that any closure means for covering the inlet opening of the housing and connected with the carrier 3 may be used. For example, a cylindrical rod, or a comb-shaped plate may be used instead of bar 9.

It will be understood that each of the elements described above, or two or more together, may also find a useful application in other types of paper guiding arrangements for business machines differing from the types described above.

While the invention has been illustrated and described as embodied in a paper guiding arrangement for a business machine including a closure means for preventing winding up of a paper band on the platen of the machine, it is not intended to be limited to the details shown, since various modifications and structural changes may be made without departing in any way from the spirit of the present invention.

We claim:

1. Paper guiding arrangement for a business machine, comprising, in combination, housing means having an inlet opening; a platen mounted in said housing means; carrier means for rotatably supporting a paper roll in a position resting on said housing means and supplying a paper band through said inlet opening to said platen so that the latter guides the leading por-

tion of said paper band back toward said paper roll, said carrier means being mounted on said housing means for movement between a first position in which said carrier means is held by a paper roll having a great diameter, and a second position in which said carrier means is held by a paper roll having a small diameter resting on said housing means; and a closure means located in the region of said inlet opening and being connected with said carrier means for movement with the same, said closure means partly covering said inlet opening in said second position for reducing said inlet opening to such a size that said paper band can still be supplied to said platen while said leading portion of said paper band, curved to a small diameter on a paper roll having a small diameter in said second position, is blocked by said closure means and cannot reenter said inlet opening, and so that said closure means opens said inlet opening in said first position of said carrier means sufficiently for the insertion of the paper band.

2. Paper guiding arrangement as claimed in claim 1 wherein said closure means forms an integral body with said carrier means, and wherein said integral body consists of a thermoplastic synthetic material.

3. Paper guiding arrangement as claimed in claim 1 wherein said carrier means include two arms located on opposite sides of said paper roll; and wherein said closure means is located between said arms and is secured to the same.

4. Paper guiding arrangement as claimed in claim 3 wherein said closure means is a bar having ends secured to said arms, respectively; and wherein said carrier means is mounted on said housing means for pivotal movement about an axis parallel to said bar.

5. Paper guiding arrangement as claimed in claim 1 comprising a paper guide mounted on said housing means between said platen and said inlet opening for guiding said paper band from said paper roll to said platen; and wherein said closure means rests on said paper band and said paper guide in said second position of said carrier means and is spaced from the same in said first position of said carrier means.

6. Paper guiding arrangement as claimed in claim 5 wherein said closure means includes a bar secured to said carrier means and having a lower edge resting on said paper band and said paper guide in said second position, and being spaced from the same in said first position of said carrier means.

7. Paper guiding arrangement as claimed in claim 5 wherein said paper guide is mounted on said carrier means for angular movement; comprising a roller mounted on said paper guide for rotation and cooperating with said platen for guiding said paper band about the same; and biasing means connected with said paper guide for urging said roller toward said platen.

8. Paper guiding arrangement as claimed in claim 1 wherein said housing means has an outlet opening; and comprising a paper holder mounted on said housing means in the region of said outlet opening and cooperating with said platen for holding said paper band on the same and for guiding a slightly curved paper band toward and over the top of a paper roll having said great diameter.

9. Paper guiding arrangement as claimed in claim 1 comprising means mounting said carrier means on said housing means for angular movement about an axis between said first and second positions; wherein said carrier means includes two arms located on opposite sides of said paper roll and having journals adapted to project into a central opening of said paper roll; wherein said closure means includes a bar parallel with said axis and having ends secured to said arms, respectively; comprising a paper guide mounted on said housing means for guiding said paper band toward said platen; and wherein said bar rests on said paper band and paper guide in said second position of said carrier means.

10. Paper guiding arrangement as claimed in claim 1 wherein said carrier means includes two arms located on opposite sides of said paper roll; and wherein said closure means is a bar extending between said arms and forming with said carrier means an integral body; and wherein said integral body consists of a thermoplastic synthetic material.