



(51) International Patent Classification:

*G02B 5/30* (2006.01)      *B29D 11/00* (2006.01)  
*B29C 43/20* (2006.01)      *G02C 7/12* (2006.01)

(21) International Application Number:

PCT/IB2012/000749

(22) International Filing Date:

16 April 2012 (16.04.2012)

(25) Filing Language:

English

(26) Publication Language:

English

(30) Priority Data:

61/475,871      15 April 2011 (15.04.2011)      US

(71) Applicant (for all designated States except US): **POLAR-  
OID EYEWEAR A DIVISION OF STYLEMARK UK,  
LTD.** [GB/GB]; Vale of Leven Industrial Estate, Dumbar-  
ton G82 2PW, Scotland, United Kingdom (GB).

(72) Inventors; and

(75) Inventors/Applicants (for US only): **BOINARD, Eric** [FR/GB]; Vale of Leven Industrial Estate, Dumbarton G82 3PW (GB). **BOINARD, Pascal** [FR/GB]; Vale of Leven Industrial Estate, Dumbarton G82 3PW (GB).

(81) Designated States (unless otherwise indicated, for every kind of national protection available): AE, AG, AL, AM,

AO, AT, AU, AZ, BA, BB, BG, BH, BR, BW, BY, BZ, CA, CH, CL, CN, CO, CR, CU, CZ, DE, DK, DM, DO, DZ, EC, EE, EG, ES, FI, GB, GD, GE, GH, GM, GT, HN, HR, HU, ID, IL, IN, IS, JP, KE, KG, KM, KN, KP, KR, KZ, LA, LC, LK, LR, LS, LT, LU, LY, MA, MD, ME, MG, MK, MN, MW, MX, MY, MZ, NA, NG, NI, NO, NZ, OM, PE, PG, PH, PL, PT, QA, RO, RS, RU, RW, SC, SD, SE, SG, SK, SL, SM, ST, SV, SY, TH, TJ, TM, TN, TR, TT, TZ, UA, UG, US, UZ, VC, VN, ZA, ZM, ZW.

(84) Designated States (unless otherwise indicated, for every kind of regional protection available): ARIPO (BW, GH, GM, KE, LR, LS, MW, MZ, NA, RW, SD, SL, SZ, TZ, UG, ZM, ZW), Eurasian (AM, AZ, BY, KG, KZ, MD, RU, TJ, TM), European (AL, AT, BE, BG, CH, CY, CZ, DE, DK, EE, ES, FI, FR, GB, GR, HR, HU, IE, IS, IT, LT, LU, LV, MC, MK, MT, NL, NO, PL, PT, RO, RS, SE, SI, SK, SM, TR), OAPI (BF, BJ, CF, CG, CI, CM, GA, GN, GQ, GW, ML, MR, NE, SN, TD, TG).

Published:

- with international search report (Art. 21(3))
- before the expiration of the time limit for amending the claims and to be republished in the event of receipt of amendments (Rule 48.2(h))

(54) Title: CURVED LENSES AND RELATED METHODS

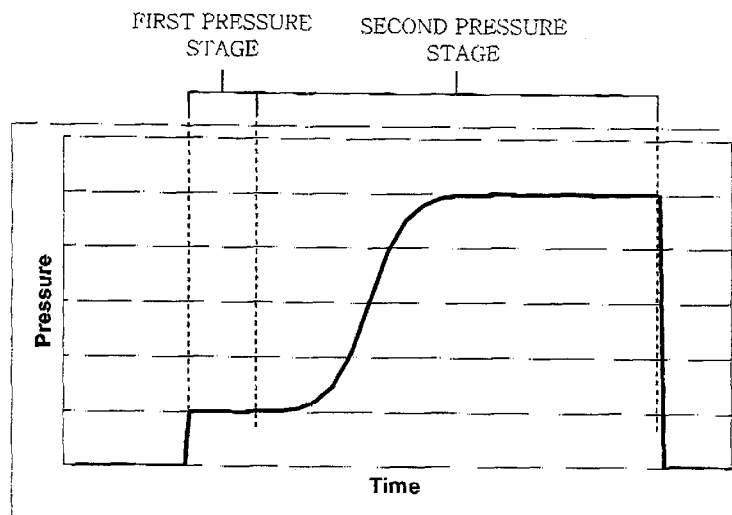

FIG. 10

(57) Abstract: Curved lenses and methods for making curved lenses are described. One embodiment of a method of making a curved lens includes curving a lens blank made of a linear polarizer layer laminated together with a plurality of polymeric layers. The lens blank is curved by heating and pressing the lens blank between a convex member and a concave member at a first pressure, ramping the pressure sigmoidally to a higher pressure over a period of time, and maintaining the higher pressure for a time sufficient to allow the lens blank to conform to the shape of the convex member and concave member. Methods of the invention may be used to make curved lenses with different polarization properties and curvatures.

WO 2012/140501 A1

## CURVED LENSES AND RELATED METHODS

### CROSS-REFERENCE TO RELATED APPLICATION

**[0001]** The application claims priority to U.S. Provisional Application Serial No. 61/475,871 titled "Apparatus and Method for Shaping Light Polarizers," which was filed on April 15, 2011 and is incorporated herein by reference in its entirety.

### FIELD OF THE INVENTION

**[0002]** The invention relates to the field of polarized eyewear, and, more particularly, to curved polarized lenses and eyewear having curved polarized lenses.

### BACKGROUND

**[0003]** Light polarizing lenses such as those incorporated into sunglasses or other eyewear are preferably shaped to comply with fashion trends, to minimize the amount of light that can disturb the wearer's peripheral vision and to minimize the appearance of reflections. Unfortunately, there are currently very few techniques that can transform planar polarizing lens blank materials into a curved lens. The techniques that exist may suffer from one or more of the following drawbacks: some may produce lenses with optical power, production is not adapted for efficient automation, some involve time consuming grinding processes, or the forming process damages the linear polarizer.

### SUMMARY

**[0004]** In view of the foregoing, it is an object of the invention to provide curved polarized lenses having substantially no optical power, which can be produced according to efficiently automated processes that impart minimal damage to the delicate linear polarizer material.

**[0005]** According to a method aspect of the invention, a formed lens is prepared from a lens blank made of a linear polarizer layer laminated together with a plurality of polymeric layers, the linear polarizer layer having a polarization axis. The lens blank is heated and pressed between a convex member and a concave member at a first pressure. The pressure is ramped sigmoidally to a higher pressure over a ramping time and the higher pressure is maintained for a time sufficient to allow the lens blank to conform to the shape of the convex member and concave member.

**[0006]** In another method aspect of the invention, a formed lens is prepared from a lens blank made of a linear polarizer layer laminated together with a plurality of polymeric layers, the linear polarizer layer having a polarization axis. The lens blank is heated to a forming temperature by pressing the lens blank at a first pressure between a convex member and a concave member, the convex member and concave member both being at the forming temperature. The pressure is ramped to a second pressure while heating at the forming temperature, wherein ramping from the first pressure to the second pressure is performed according to a sigmoidal pressure profile. The second pressure is maintained while heating at the forming temperature for allowing the lens blank to conform to the shape of the convex member and concave member. The temperature is reduced to a reduced temperature while maintaining the second pressure for allowing the lens blank to become a rigid lens having a convex side and a concave side. The rigid lens is then removed from between the convex member and concave member.

**[0007]** In another method aspect of the invention, eyewear is prepared from a first lens and a second lens made of a linear polarizer layer laminated together with a plurality of polymeric layers, the linear polarizer layer having a polarization axis. The first lens and second lens are formed from lens blanks into a desired shape according to the following steps: (i) heating and pressing the lens blanks separately between a convex member and a concave member at a first pressure, (ii) ramping the pressure sigmoidally to a higher

pressure over a ramping time, and (iii) maintaining the higher pressure for a time sufficient to allow the lens blanks to conform to the shape of the convex member and concave member. The formed first and second lenses are then placed into an eyeglass frame.

**[0008]** The following are preferred forming parameters that may optionally be used in methods of the invention. Heating is preferably conducted at about 70°C to about 200°C. The first pressure is about 0.75 to about 2.5 MPa. The second pressure is about 1.5 to about 32 MPa. The ramping time is preferably about 5 to about 150 seconds.

**[0009]** In some embodiments, a method may comprise cooling the lens blank while maintaining the second pressure. Cooling may be conducted at about 20°C to about 90°C.

**[0010]** In some embodiments, a method may comprise, heating the lens blank to a temperature of between about 20°C to about 150°C prior to placing the lens blank between the convex member and concave member and pressing the lens blank at the first pressure.

**[0011]** In certain embodiments, at least one of the polymeric layers is an optical wave retarder having fast and slow axes and the fast retarder axis is aligned at an angle relative to the polarizer axis. The angle may be chosen to render the lens a linear polarizer, an elliptical polarizer, or a circular polarizer.

**[0012]** In embodiments in which the lens is a circular polarizer, an anti-reflective coating may be applied to the concave surface and convex surface of the formed lens. This advantageously allows the formed lens to have a parallel polarizer transmittance equal to or greater than 90% and a cross polarizer transmittance equal to or less than 0.5%.

**[0013]** In some embodiments, the shape of the convex member and concave member may be adjusted to produce a spherically, toroidally, or cylindrically shaped lens. A spherically shaped lens has a first radius of curvature and a

second radius of curvature perpendicular to the first radius of curvature, wherein the first radius of curvature and second radius of curvature are equal. A toroidally shaped lens has a first radius of curvature and a second radius of curvature perpendicular to the first radius of curvature, wherein the first radius of curvature and second radius of curvature are not equal. A cylindrically shaped lens has a first radius of curvature and a second radius of curvature perpendicular to the first radius of curvature, wherein the first radius of curvature is non-zero and second radius of curvature is zero.

**[0014]** In some embodiments, the shape of the convex member and concave member produces a lens having non-uniform thickness with a maximum thickness of the lens being located proximal to the center of the lens, which advantageously allows the lens to have substantially no optical power.

**[0015]** Embodiments of the invention also include eyeglass lenses made according to method aspects of the invention.

**[0016]** These and other objects, aspects, and advantages of the present invention will be better appreciated in view of the drawings and following detailed description of the preferred embodiments.

#### BRIEF DESCRIPTION OF THE DRAWINGS

**[0017]** FIG. 1 is a side elevation view of a preferred composite light polarizer sheet that can be used to form a lens in accordance with an embodiment of the invention;

**[0018]** FIG. 2 is a side elevation view of another preferred composite light polarizer sheet that can be used to form a lens in accordance with an embodiment of the invention;

**[0019]** FIG. 3 is a side elevation view of another preferred composite light polarizer sheet that can be used to form a lens in accordance with an embodiment of the invention;

**[0020]** FIG. 4. is a plan view of a preferred composite light polarizer sheet from which a lens blank can be cut, showing the alignment of the transmission axis of the linear polarizer layer and the fast axis of the retarder layer;

**[0021]** FIG. 5 is a plan view of a section of a composite light polarizer sheet, showing how lens blanks may be cut therefrom;

**[0022]** FIG. 6 is a plan view of a lens blank removed from the section of composite light polarizer sheet of FIG. 4;

**[0023]** FIG. 7 is a cross-sectional view of an apparatus that can be used to curve lens blanks into lenses according to a method aspect of the invention;

**[0024]** FIG. 8 is a cross-sectional view of the apparatus of FIG. 7 during a pressure stage of a method aspect of the invention;

**[0025]** FIG. 9 is a cross-sectional view of the apparatus of FIG. 7, showing a curved lens removed from the apparatus;

**[0026]** FIG. 10 is a line graph showing a typical sigmoidal pressure profile used in forming a lens blank into a curved lens, according to a method aspect of the invention;

**[0027]** FIGS. 11A-C are schematics of spherically, toroidally, and cylindrically shaped lenses, respectively, made according to a method aspect of the invention;

**[0028]** FIG. 12 is a perspective view of eyeglasses incorporating lenses of the invention;

**[0029]** FIG. 13 is a cutaway view of a curved lens including a hard coating in accordance with an embodiment of the invention; and

**[0030]** FIG. 14 is a cutaway view of a curved lens including an anti-reflective coating in accordance with an embodiment of the invention.

## DETAILED DESCRIPTION OF PREFERRED EMBODIMENTS

**[0031]** In the Summary above and in the Detailed Description of Preferred Embodiments, reference is made to particular features (including method steps) of the invention. It is to be understood that the disclosure of the invention in this specification includes all possible combinations of such particular features. For example, where a particular feature is disclosed in the context of a particular aspect or embodiment of the invention, that feature can also be used, to the extent possible, in combination with and/or in the context of other particular aspects and embodiments of the invention, and in the invention generally.

**[0032]** The term "comprises" is used herein to mean that other features, steps, etc. are optionally present. When reference is made herein to a method comprising two or more defined steps, the steps can be carried in any order or simultaneously (except where the context excludes that possibility), and the method can include one or more steps which are carried out before any of the defined steps, between two of the defined steps, or after all of the defined steps (except where the context excludes that possibility).

**[0033]** This invention may be embodied in many different forms and should not be construed as limited to the embodiments set forth herein.

**[0034]** A drawback of typical curved polarized lenses is that lenses of uniform thickness have optical power. Because the optical power increases with the thickness and curvature of a lens, increasing the thickness and/or the curvature of a lens, for the purpose of increasing its durability, undesirably increases the optical power. One process for making curved polarized lenses with substantially no optical power is described in U.S. Patent No. 5,434,707 to Dalzell, which is incorporated herein by reference in its entirety. Dalzell's process involves pressing its lens making material between two heated glass molds in a single pressure application step. Unfortunately, the inventors have found that Dalzell's process may create a defect in the lenses known as "split

haze," which results from the break-up of the delicate linear polarizer material when heat and pressure are applied. The thicker and curvier the lens, the more significant the damage to the linear polarizer material. Split haze reduces the optical clarity and diminishes the polarization efficiency of the lens.

**[0035]**As will be described below, the invention described here overcomes these drawbacks. The inventors have advantageously developed thick and durable curved lenses with minimal or no damage to the linear polarizer material using a unique forming process involving pressing the lens blanks in multiple pressure application stages.

**[0036]**FIGS. 1-3 illustrate exemplary composite light polarizer sheets from which the curved polarized lenses of the invention may be formed. Referring initially to FIG. 1, an exemplary sheet 1 includes a polarizer layer 12 laminated between first and second polymeric layers 14, 16. A protective hardcoat layer 5 is coated on top of both polymeric layers 14, 16. Referring to FIG. 2 another exemplary sheet 10 includes a polarizer layer 12 laminated between first and second polymeric layers 14, 16 and a retarder layer 18 laminated to the second polymeric layer 16. Referring now to FIG. 3, an alternative example of a sheet 20 includes a polarizer layer 12 laminated to a first polymeric layer 14 on one side and to a retarder layer 18 on the other side. A second polymeric layer 16 is laminated to the retarder layer 18 on the side of the retarder layer 18 that is opposite the polarizer layer 12.

**[0037]**The polarizer layer 12 is preferably a linear polarizer, which may be made of any number of suitable linear polarizer materials such as H-type or K-type polarizers. In a preferred example, the polarizer material is made from a linear molecularly oriented dichroic light-polarizing material. Such materials typically have a thickness in the range of about 0.025 to 0.076 mm. A preferred material to serve as the light polarizer is a layer of stretched (oriented) polyvinyl alcohol of about 0.025mm thickness, which is stained with a dichroic dye such as iodine. Optionally, the polarizer may be borated to



improve stability. Polarizers of this type are disclosed in U.S. Reissue Pat. Re. 23,297 and in U.S. Pat. No. 4,166,871.

**[0038]** Alternatively, the polarizer material may be a stretched polyvinyl alcohol (PVA) sheet containing polyvinylene light-polarizing species such as may be provided by typical hydrochloric acid vapor processing. Preferably, such polarizing material will be borated for improved stability. Suitable light-polarizing materials of this type can be prepared according to U.S. Pat. No. 2,445,555. Other light polarizing materials such as those described in U.S. Pat. Nos. 2,237,567; 2,527,400; and 2,554,850 may also be used. Regardless of the type of polarizer material used, the polarizer material may be sandwiched to or between one or more support layers, such as a polymeric material layer **14**, **16** to provide mechanical strength to the polarizer layer **12**.

**[0039]** The polymeric layers **14**, **16** are preferably made from one or more thermoplastic polymers, which are polymers that can be formed to a desired shape by applying temperature and/or pressure. Suitable polymers include, but are not limited to, cellulose derivatives such as cellulose acetate, cellulose diacetate, cellulose triacetate, or cellulose acetate butyrate; acrylate derivatives such as polymethylmethacrylate (PMMA); polycarbonates; polyamides, polyurethanes; polypropylenes; polyethylenes; or cyclo-olefin based polymers or copolymers. The polymeric material layers **14**, **16** may be made from a single layer of a single polymer, a single layer of a blend of polymers, multiple laminated layers of a single polymer, or multiple laminated layers made of different polymers or a blend of polymers.

**[0040]** It is preferred that the polymeric layers **14**, **16** provide durability, mechanical strength, and scratch resistance to the sheet **12** and the finished curved lens made from the sheet **12**. In some cases, it may be beneficial to use polymers that either carry or may be provided with a suitable protective coating such a polymeric hard coating **5** that can withstand the temperatures and pressures used in the forming process. Suitable protective coatings include polyurethanes, polyacrylates, or urea-based resins.

**[0041]**The retarder layer **18** is preferably made from a light transmissive birefringent material such as a cyclo-olefin based polymer or co-polymer. Other suitable materials that can be used to form the retarder layer **18** include, but are not limited to, acrylate based polymer, polypropylenes, polyesters, cellulose acetate based polymers, PVA, polystyrenes, polycarbonates, and norbornene based polymers and co-polymers.

**[0042]**One or more additives may be included in the polarizer layer **12**, polymeric layers **14**, **16** and/or retarder layer **18**. For example, stabilizers, UV absorbers, and colorant dyes may be employed depending on the desired properties of the finished curved optical filter.

**[0043]**The polarizer layer **12** and retarder layer **18** include axes that may be aligned relative to one another to produce a desired polarization effect. Referring to FIG. 4, an exemplary sheet **30** having polarizer layer **12** and a retarder layer **18** is shown. The polarizer layer **12** has a transmission axis **T** aligned at the angle  $\theta$ . The fast axis **R** of the retarder layer **18**, is aligned at the angle  $\varphi = \theta + \beta$  where  $\beta$  is the angular offset of the fast axis **R** of the retarder layer **18** relative to the transmission axis **T** of the polarizer layer **12**. When  $\beta = (n-1) (\pi/2)$  with  $n$  an integer, the two axes are either parallel or orthogonal to each other and the sheet **30** behaves as a linear polarizer. When  $\beta = (2n-1) (\pi/4)$  with  $n$  an integer, the sheet **30** behaves as a circular polarizer. For any other values of  $\beta$ , the sheet **30** behaves as an elliptical polarizer.

**[0044]**In more detail, the linear polarizer layer **12** has a transmission axis **T** oriented at  $\theta$  and defined by the Stoke vector of Eq. (1).

$$\text{Eq. (1).} \quad \frac{1}{2} \begin{pmatrix} S_0 + S_1 \cdot \cos 2\theta + S_2 \cdot \sin 2\theta \\ S_0 \cdot \cos 2\theta + S_1 \cdot \cos^2 2\theta + S_2 \cdot \sin 2\theta \cos 2\theta \\ S_0 \cdot \sin 2\theta + S_1 \cdot \sin 2\theta \cos 2\theta + S_2 \cdot \sin^2 2\theta \\ S_3 \end{pmatrix}$$

The polarizer comprises a linear polarizer layer **12** with transmission axis **T** orientated at  $\theta$  and a retarder layer with its fast axis **R** aligned at  $\phi$  defined by the Stoke vector of Equation 2.

Eq. (2).

$$\frac{1}{2} \begin{pmatrix} S_0 + \cos 2\theta \cdot (S_1 \cos^2 2\phi + S_2 \cos 2\phi \sin 2\phi - S_3 \sin 2\phi) + \sin 2\theta \cdot (S_1 \cos 2\phi \sin 2\phi + S_2 \sin^2 2\phi + S_3 \cos 2\phi) \\ \cos 2\theta \cdot S_0 + \cos^2 2\theta \cdot (S_1 \cos^2 2\phi + S_2 \cos 2\phi \sin 2\phi - S_3 \sin 2\phi) + \sin 2\theta \cos 2\theta \cdot (S_1 \cos 2\phi \sin 2\phi + S_2 \sin^2 2\phi + S_3 \cos 2\phi) \\ \sin 2\theta \cdot S_0 + \sin 2\theta \cos 2\theta \cdot (S_1 \cos^2 2\phi + S_2 \cos 2\phi \sin 2\phi - S_3 \sin 2\phi) + \sin^2 2\theta \cdot (S_1 \cos 2\phi \sin 2\phi + S_2 \sin^2 2\phi + S_3 \cos 2\phi) \\ S_1 \sin 2\phi - S_2 \cos 2\phi \end{pmatrix}$$

$$S = \begin{pmatrix} S_0 \\ S_1 \\ S_2 \\ S_3 \end{pmatrix} \text{ defines the Stoke vector of light that is transmitted though the sheet}$$

**30.**

**[0045]** Using these relationships any number of sheets **1, 10, 20, 30** configurations can be formed depending on the desired polarization properties of the sheet **1, 10, 20, 30** and the finished curved lens. In practice one may form a sheet **10, 20, 30** having desired polarization properties by predetermining the desired polarization properties of the sheet **10, 20, 30** and then forming the sheet **10, 20, 30** in such a way that the fast axis **R** of the retarder layer **18** is aligned at the desired angle relative to the polarization axis **T** of the polarizer layer **12** to achieve the desired polarization properties.

**[0046]** In preparation for making a curved lens, lens blanks may be prepared by cutting and removing blanks of a size and shape suited for the production of the desired lens from a composite light polarizer sheet of the invention. A preferred method of preparing a blank to be formed into a lens is shown in FIG. 4, which is a plan view of a section of sheet **40** from which blanks **42, 44** are cut and removed. The blanks **42, 44** are prepared by making a cut **46** through the section of sheet **40**. The cut **46** defines the perimeter of an individual blank **42, 44** from which a blank **48** can be removed as shown in FIG. 5. Suitable methods of making the cut **46** include the use of a rolling

knife cutter, a reciprocal stamping cutter, a straight edge cutting knife, a rotary die, or a laser cutter.

**[0047]** Individual blanks, such as blank **48** shown in FIG. **5**, may be formed into lenses in the manner described below. In certain embodiments, the blanks **48** may be subjected to one or more pre-forming treatments such as cleaning, coating, or polishing if desired.

**[0048]** A method by which a blank **48** of the invention is formed into a lens that is concave on one side and convex on the other side will now be described in connection with FIGS. **7** through **9**.

**[0049]** The forming process can be carried out by an apparatus **50** of the type shown in FIG. **7**. The apparatus includes concave platen **52**, convex platen **54**, a mechanism for driving the platens into and out of pressure-applying relationship with each other, and mechanism for alternately heating and cooling the platens during each pressure-applying interval.

**[0050]** Concave platen **52** includes a metal member **56**, a fixed support **60**, a fluid chamber **62**, fluid inlet coupling **64**, and fluid outlet coupling **66**. The metal member **56** has a smooth concave forming surface **58**.

**[0051]** Convex platen **54** includes metal member **68**, shaft **72** operatively connected to a suitable drive mechanism, fluid chamber **74**, fluid inlet coupling **76** and fluid outlet coupling **78**. The metal member **68** has a smooth convex forming surface **70**.

**[0052]** The use of the metal members **56**, **68** is advantageous over conventional lens press molds such as the glass molds described in Dalzell. Due to their fragility and complexity, the glass molds only allowed for spherical lenses to be formed. Moreover, concave and convex glass molds would not be able to withstand the higher pressures needed to form some of today's thicker and tougher curved lenses, such as the lenses of the invention. Further, metal members **56**, **68** with different shapes may be interchanged to match a desired

lens curvature. Therefore, rather than just being able to form spherically curved lenses, as one would with the conventional glass molds, the invention allows for toroidally or cylindrically shaped lenses to be formed simply by selecting a suitably shaped set of metal members **56**, **68**. Furthermore, metal members **56**, **68** can be designed with a de-centered curvature allowing to form lenses with their optical centres away from their geometric centres. This is of special interest in minimizing the potential prismatic power effect that can be generated when mounting thick lenses with high curvatures in an eyeglass frame of the wrap-around style. Due to the fragility and low heat transfer of glass, lens de-centering would be difficult to achieve with glass molds.

**[0053]** A preferred drive mechanism includes a suitable hydraulic piston and cylinder arrangement **80** operatively connected to convex platen **54** for moving the convex platen **54** into and out of pressure-applying relationship with the concave platen **52**.

**[0054]** A preferred heating and cooling mechanism for both platens **52**, **54** includes a three-way valve **82**, a heating fluid conduit **84**, a cooling fluid conduit **86**, and fluid inlet **88** connecting one of the three way valves **82** to each of fluid inlet couplings **64**, **76** of the platens **52**, **54** respectively.

**[0055]** In forming a curved lens, a blank **48** is placed on the smooth concave forming surface **58**. The the smooth concave forming surface **58** and the smooth convex forming surface **70** are then moved into contact with the blank **48** as shown in FIG. 8.

**[0056]** The inventors discovered that the undesirable "split haze" effect discussed previously is avoidable by applying pressure to the blank **48** in multiple pressure application stages. In a first pressure stage relatively low pressure is applied to allow for efficient heat transfer to the blank **48**. This is followed by a second pressure stage in which the pressure is ramped over a pre-determined time period, allowing for a smooth flow of the blank **48** material, thereby preventing damage to the polarizer layer **12**.

**[0057]** In the first pressure stage, relatively low pressure is applied in order to transfer heat from the surfaces **58, 70** to the blank **48**. In the second pressure stage, the pressure is ramped in order to form or shape the blank **48**, by the combined effects of pressure and temperature, into a shaped lens of non-uniform thickness characterized by concave and convex opposed surfaces and maximum thickness in the central region of the lens.

**[0058]** The amount of pressure applied, the pressure profile and the time delay between the first and second pressure stages may be adjusted depending on the characteristics of the blank **48**, with the temperatures of the forming surfaces **58** and **70** and with the curvature intended to be given to the blank **48**.

**[0059]** A typical ramping pressure profile is presented in FIG. **10**. In a preferred embodiment, the pressure applied to the blank **48** during the first pressure stage is in the range of about 0.75 to about 2.50 MPa and the pressure applied to the blank in the second stage is in the range of about 1.50 to about 32 MPa. The pressure is preferably ramped between the first pressure and second pressure according to a sigmoidal pressure profile as shown. A preferred range for the ramping time is 1 second or more, or more preferably about 5 seconds to about 150 seconds.

**[0060]** During the pressure stages, the platens **52, 54** are heated by passing hot fluid through the fluid chambers **62, 74** of platens **52** and **54**, respectively. Surfaces **58** and **70** are continually heated sufficiently to cause deformation and flow of the lens blank **48** material and conformation of the surfaces of blank **48** to the forming surfaces **58, 70**. Thermoplastic flow and application of pressure by the platens **52, 54** onto the blank **48** therebetween causes the blank **48** to deform and fill the space between the platens **52, 54**, producing a curved polarizer of non-uniform thickness and substantially no optical power.

**[0061]** If the conditions of temperature and pressure are insufficient to cause the blank **48** to fill the space between the forming surfaces **58, 70**, the blank

**48** will retain its uniform thickness, thereby resulting in a lens having optical power.

**[0062]** In the production of a curved lens of the invention, it will be convenient to utilize a platen **52** having a forming surface **58** corresponding to a predetermined curvature of the convex side of the lens to be formed. The convex surface of the lens, formed against forming surface **58**, may serve as the outer surface of an eyeglass lens. A suitable radius of curvature for surface **58** for forming a convex lens surface is about 50 to about 270 mm, or about 65 to about 90 mm. In a particular embodiment, the radius of curvature is about 87.2mm.

**[0063]** The temperature sufficient to cause the blank **48** to deform may vary with the chemical composition of the blank's **48** composite structure. A preferred heating temperature range is between about 70°C to about 200°C. Another preferred heating range is between about 90°C to about 110°C. One particular preferred heating temperature is about 105°C.

**[0064]** In some cases it may be helpful to pre-heat the blank **48** before applying pressure. Suitable pre-heating temperatures are within the range of about 20°C to about 150°C.

**[0065]** The temperature of the forming surfaces **58**, **70** of the platens **52**, **54** can be controlled by the passage of heated fluid and cooled fluid, as described previously. The platens **52**, **54** are preferably preheated, prior to placement of the blank therebetween, to the desired forming temperature for a heating cycle sufficient to provide the desired shaped lens. The desired forming temperature is maintained for a duration sufficient to effect desired lens formation. Although not limiting, a suitable duration is between about 80 to about 90 seconds. Thereafter, the temperature of the forming surfaces **58**, **70** is reduced by passing a cooling fluid, through the fluid chambers **62**, **74** of the platens **52**, **54**. The cooling fluid is passed through the platens **52**, **54** for a time sufficient to cool the formed lens. Although not limiting, a suitable cooling duration is

about 30 seconds. Cooling temperatures from about 20°C to about 35°C provide good results, but other cooling temperatures are also contemplated.

**[0066]** Hot fluid is supplied to the platens **52, 54** through the heating fluid conduits **84** and the relatively cool fluid is supplied through the cooling fluid conduits **86**. During the heating cycle, the valves **82** open a connecting passage between the heating fluid conduits **84** and the respective inlets **64, 76** and closes the cooling fluid conduit **86**. During the cooling cycle, the valves **82** open a connecting passage between the cooling fluid conduits **86** and the respective inlets **64, 76** and closes the heating fluid conduit **84**. The transition from the heating cycle to the cooling cycle is carried out by operating valves **82** to mix cool fluid with the hot fluid until the hot fluid is completely displaced by cool fluid. Transition from the cooling cycle to heating cycle is carried out by reversing the operation.

**[0067]** After the cooling operation, the platens **52, 54** are separated to relieve the pressure on the formed lens **90** and permit its removal, as shown in FIG. **9**. If the formed lens **90** adheres to one of the platens **52, 54**, it may be removed by applying a stream of compressed air.

**[0068]** One or more coatings can be applied on the concave and/or convex surfaces of the formed lens **90** using conventional vacuum deposition techniques. The inventors discovered that applying an anti-reflective coating to the convex and concave surfaces of a circular polarizer lens of the invention can significantly improve the transmittance % of the finished circular polarizer lens.

**[0069]** The method described above can also include repeating each of these steps using a series of concave and convex platens **52, 54** for the shaping of blanks **48** to each of a series of convex lens surfaces, each of such surfaces having a different curvatures within a desired range of curvatures, thus providing a series of lenses, each having a different convex surface within a desired range of curvatures.



**[0070]** A lens of the invention may also gradually be shaped to a desired form by repeating the steps and gradually increasing the curvature of the platens **52, 54** prior to each repetition. This can be accomplished using a series of platens **52, 54** with each set in the series having an increased curvature relative to the prior set.

**[0071]** The shape of a formed lens of the invention will substantially correspond to the shape of the forming surfaces **58, 70**. Accordingly, different shaped forming surface **58, 70** can be used to form lenses with different curvatures. For example, a pair of spherically shaped, a pair of cylindrically shaped, or a pair of toroidally shaped forming surfaces **58, 70** can be used to form spherically curved, cylindrically curved, and toroidally curved light polarizer lenses, respectively.

**[0072]** For spherically, toroidally, and cylindrically curved lenses, the shape of the lens, along the first principal meridian corresponds substantially to the relationship  $(n-1) [1/r_{11}-1/r_{21}+((n-1)/n) t/(r_{11}r_{21})]=0$ , the shape of the lens along the second principal meridian, perpendicular to the first principal meridian, corresponds substantially to the relationship  $(n-1) [1/r_{12}-1/r_{22}+((n-1)/n) t/(r_{12}r_{22})]=0$ ,  $t$  represents the thickness of the blank **48**,  $n$  is its index of refraction,  $r_{11}$  and  $r_{12}$  are the radii of curvature of each principal meridian of the concave forming surface **58** and  $r_{21}$  and  $r_{22}$  are the radii of curvature of each principal meridian of the convex forming surface **70**. In preferred embodiments,  $r_{11}$ ,  $r_{12}$ ,  $r_{21}$  and  $r_{22}$  are typically in the range of about 1 to about 10 diopters and the thickness is typically in the range of about 0.2 mm to about 2.5 mm. To form a spherically curved lens  $r_{11}$  equals  $r_{12}$  and  $r_{21}$  equals  $r_{22}$ . To form a toroidally curved lens  $r_{11}$  is different from  $r_{12}$  and  $r_{21}$  is different from  $r_{22}$ . To form a cylindrically curved lens,  $r_{11}$  is different from  $r_{12}$  and  $r_{12}$  is about 0 diopters. This relationship can also apply to other shaped curvatures.

**[0073]** FIGS. **11A-C** depict a formed spherical lens **90'**, a formed toroidal lens **90''**, and a formed cylindrical lens **90'''**, respectively. The curvature of each

lens **90'**, **90''**, **90'''** is characterized by a first radius of curvature  $r_{11}$  and a second radius of curvature  $r_{12}$ . The lines along which  $r_{11}$  and  $r_{12}$  are determined are indicated. For a spherically curved lens **90'**,  $r_{11}$  equals  $r_{12}$ . For toroidally curved lens **90''**,  $r_{11}$  is different from  $r_{12}$ . For a cylindrically curved lens **90'''**,  $r_{12}$  is about 0 diopter.

**[0074]** Another object of the invention is to provide polarized eyewear that includes two lenses of the invention. Referring to FIG. 12, the eyewear **100** includes an eyeglass frame **102**, a first lens **104** and a second lens **106**. The lenses **104**, **106** may be the same or different, depending on the desired use of the eyewear. For the manufacture of linear polarized eyewear, the first lens **104** and second lens **106** are identical. The sheet used for these lenses will have a stoke vector as described in Equation 1 with the polarizer axis orientated parallel to the horizontal ( $\theta=0$ ). In some preferred examples for stereoscopic use, both lenses are made of linear polarizer sheet having a stoke vector as described in Equation 1 with the polarizer axis of the first lens **104** orientated at  $\theta$  and the polarizer axis of the second lens **106** orientated at  $\theta+\pi/2$ . In a further preferred example for stereoscopic use, the sheet material comprises a retarder layer **18** and has a Stoke vector as described in Equation 2. The first lens **104** has its polarizer axis **T** orientated at  $\theta$  and fast axis of the retarder **R** orientated at  $\varphi = \theta + \beta$  and the second lens **106** has its polarizer axis **T** orientated at  $\theta$  and fast axis of the retarder **R** orientated at  $\varphi = \theta - \beta$ .

## EXAMPLES

**[0075]** In this section, certain illustrative embodiments of the invention are described. These are provided by way of example only and, therefore, do not limit the scope of the invention.

### EXAMPLE 1

#### PREPARATION OF A LENS OF THE INVENTION

**[0076]** A spherically shaped linear polarizer lens of the invention was prepared using the method and apparatus described above. The structure of the lens

112 will be better understood by referring to FIG. 13. The lens 112 was formed from a total of six layers of material including a polarizer layer 12, a first polymeric layer 14, a second polymeric layer 16, a third polymeric layer 118, a first hard coat layer 114 and a second hard coat layer 116. The lens has its maximum thickness in the central portion. The materials used to make the lens 112, the properties of the platens, and the forming parameters are all specified in TABLE 1.

**TABLE 1. Materials and Parameters Used to Form an Exemplary Lens of the Invention**

Lens Materials	Layer 1 (114)		hardcoat
	Layer 2 (118)		cellulose triacetate
	Layer 3 (16)		cellulose triacetate
	Layer 4 (12)		stretched PVA with iodine
	Layer 5 (14)		cellulose triacetate
	Layer 6 (116)		hardcoat
	Thickness of blank material		0.8mm
Platens	Material		steel
	Radius (r11= r21)		87.2 mm
Forming Parameters	Temperatures	pre-heating	50-70°C
		heating	90-100°C
		cooling	20-35°C
	Pressures	stage 1	1.4-1.6 MPa
		stage 2	8-10 MPa
		ramping time	8-12 seconds

**EXAMPLE 2**

**IMPROVEMENT OF TRANSMITTANCE USING ANTI-REFLECTIVE COATINGS ON CIRCULAR POLARIZED LENSES**

[0077]Circular polarizer lenses of the invention were coated on both the convex and concave surfaces with an anti-reflective coating in order to determine whether an anti-reflective coating can improve the transmittance %

within the wavelength range of 280 to 700 nm, which includes the visible light spectrum. The structure of a circular polarized lens including an antireflective coating will be better understood with reference to FIG. 14 in which the lens 120 includes a polarizer layer 12, a first polymeric layer 14, a second polymeric layer 16, a retarder layer 18, a first antireflective coating layer 122 and a second antireflective coating layer 124.

[0078] TABLE 2 shows results of typical transmittance % improvement.

**TABLE 2. Transmittance Improvement Data**

Anti-reflective coating applied?	Cross polarizer transmittance (%)	Parallel polarizer transmittance (%)
NO	0.02	82
YES	0.03	90

[0079] The application of an anti-reflective coating is used regularly in eyewear products. For both sunglass and corrective eyewear it is applied to the back of the lens to minimize disturbing back reflections on the lens from light sources situated behind the wearer. For corrective eyewear, it is also applied at the front of the lens for cosmetic reasons, namely in order to prevent reflections from the front of the lenses, making the eyewear less noticeable.

[0080] We found that when anti-reflective coatings are applied to stereoscopic eyewear as described in this example, the coating advantageously and significantly increases the transmittance of the light the lens is designed to transmit without increasing the transmittance of the light the lens is designed to block. In this case, the lenses were designed to maximize the parallel polarizer transmittance, while minimizing the cross-polarizer transmittance. The results show that the anti-reflective coating allowed us to increase by the parallel polarizer transmittance by 8% with minimal increase in the cross-polarizer transmittance. This is especially important to 3D projection operators,

such as cinema operators, since a significant amount of light is lost in the 3D display. The ability of the eyewear to transmit more light allows the operators to use less powerful light sources resulting in significant operational cost savings.

**[0081]** The present invention has been described hereinabove with reference to the accompanying drawings, in which preferred embodiments of the invention are shown. Unless otherwise defined, all technical and scientific terms used herein are intended to have the same meaning as commonly understood in the art to which this invention pertains and at the time of its filing. Although various methods and materials similar or equivalent to those described herein can be used in the practice or testing of the present invention, suitable methods and materials are described. The skilled should understand that the methods and materials used and described are examples and may not be the only ones suitable for use in the invention.

**[0082]** Accordingly, this invention may be embodied in many different forms and should not be construed as limited to the illustrated embodiments set forth herein. The invention has been described in some detail, but it will be apparent that various modifications and changes can be made within the spirit and scope of the invention as described in the foregoing specification and as defined in the appended claims.

**THAT WHICH IS CLAIMED IS:**

1. A method of making a formed lens, the method comprising:

obtaining a lens blank comprising, in superposed relation, a linear polarizer layer laminated together with a plurality of polymeric layers, the linear polarizer layer having a polarization axis;

heating and pressing the lens blank between a convex member and a concave member at a first pressure;

ramping the pressure sigmoidally to a higher pressure over a ramping time; and

maintaining the higher pressure for a time sufficient to allow the lens blank to conform to the shape of the convex member and concave member.

2. The method of claim 1, wherein heating is conducted at about 70°C to about 200°C.

3. The method of claim 1, wherein the first pressure is about 0.75 MPa to about 2.50 MPa.

4. The method of claim 1, wherein the second pressure is about about 1.5 MPa to about 32 MPa.

5. The method of claim 1, wherein the ramping time is about 5 to about 150 seconds.

6. The method of claim 1, further comprising cooling the lens blank while maintaining the second pressure.
7. The method of claim 6, wherein cooling is conducted at about 20° C to about 90° C.
8. The method of claim 1, further comprising, preheating the lens blank to a temperature of about 20° C to about 150° C prior to applying the first pressure.
9. The method of claim 1, wherein at least one of the polymeric layers is an optical wave retarder having a fast axis and the fast axis is aligned at an angle relative to the polarizer axis.
10. The method of claim 9, wherein the angle renders the lens a linear polarizer.
11. The method of claim 9, wherein the angle renders the lens an elliptical polarizer.
12. The method of claim 9, wherein the angle renders the lens a circular polarizer.

**13.** The method of claim **9**, further comprising coating a concave surface and a convex surface of the formed lens with an anti-reflective coating.

**14.** The method of claim **13**, wherein the formed lens has a parallel polarizer transmittance equal to or greater than 90% and a cross polarizer transmittance equal to or less than 0.5%

**15.** The method of claim **1**, wherein the shape of the convex member and concave member produce a spherically shaped lens having a first radius of curvature and a second radius of curvature perpendicular to the first radius of curvature, wherein the first radius of curvature and second radius of curvature are equal.

**16.** The method of claim **1**, wherein the shape of the convex member and concave member produce a toroidally shaped lens having a first radius of curvature and a second radius of curvature perpendicular to the first radius of curvature, wherein the first radius of curvature and second radius of curvature are not equal.

**17.** The method of claim **1**, wherein the shape of the convex member and concave member produce a cylindrically shaped lens having a first radius of curvature and a second radius of curvature perpendicular to the first radius of curvature, wherein the first radius of curvature is non-zero and the second radius of curvature is zero.



18. The method of claim 1, wherein the shapes of the convex member and concave member produce a lens having non-uniform thickness.

19. An eyeglass lens made according to the method of claim 1.

20. A method of making a formed lens, the method comprising:

obtaining a lens blank comprising, in superposed relation, a linear polarizer layer laminated together with a plurality of polymeric layers, the linear polarizer layer having a polarization axis;

heating the lens blank to a forming temperature by pressing the lens blank at a first pressure between a convex member and a concave member, the convex member and concave member both being at the forming temperature;

ramping the pressure to a second pressure while heating at the forming temperature, wherein ramping from the first pressure to the second pressure is performed according to a sigmoidal pressure profile;

maintaining the second pressure while heating at the forming temperature for allowing the lens blank to conform to the shape of the convex member and concave member;

reducing the temperature to a reduced temperature while maintaining the second pressure for allowing the lens blank to become a rigid lens having a convex side and a concave side; and

removing the rigid lens from between the convex member and concave member.

21. The method of claim 20, wherein the forming temperature is about 70°C to about 200° C.

22. The method of claim 20, wherein the first pressure is about 0.75 MPa to about 2.50 MPa.

23. The method of claim 20, wherein the second pressure is about 1.5 MPa to about 32 MPa.

24. The method of claim 20, wherein a time for ramping from the first pressure to the second pressure is about 5 to about 150 seconds.

25. The method of claim 20, wherein the reduced temperature is about 20°C to about 90° C.

26. The method of claim 20, further comprising, preheating the lens blank to a temperature of about 20° C to about 150° C prior to applying the first pressure.

27. The method of claim 20, wherein at least one of the polymeric layers is an optical wave retarder having a fast axis and the fast axis is aligned at an angle relative to the polarizer axis.

**28.** The method of claim **27**, wherein the angle renders the lens a linear polarizer.

**29.** The method of claim **27**, wherein the angle renders the lens an elliptical polarizer.

**30.** The method of claim **27**, wherein the angle renders the lens a circular polarizer.

**31.** The method of claim **27**, further comprising coating a concave surface and a convex surface of the formed lens with an anti-reflective coating.

**32.** The method of claim **31**, wherein the formed lens has a parallel polarizer transmittance equal to or greater than 90% and a cross polarizer transmittance equal to or less than 0.5%

**33.** The method of claim **20**, wherein the shape of the convex member and concave member produce a spherically shaped lens having a first radius of curvature and a second radius of curvature perpendicular to the first radius of curvature, wherein the first radius of curvature and second radius of curvature are equal.

**34.** The method of claim **20**, wherein the shape of the convex member and concave member produce a toroidally shaped lens having a first radius of curvature and a second radius of curvature perpendicular to the first radius of

curvature, wherein the first radius of curvature and second radius of curvature are not equal.

**35.** The method of claim **20**, wherein the shape of the convex member and concave member produce a cylindrically shaped lens having a first radius of curvature and a second radius of curvature perpendicular to the first radius of curvature, wherein the first radius of curvature is non-zero and the second radius of curvature is zero.

**36.** The method of claim **20**, wherein the shape of the convex member and concave member produce a lens having non-uniform thickness.

**37.** An eyeglass lens made according to the method of claim **20**.

**38.** A method of making eyewear, the method comprising:

(a) obtaining a first lens and a second lens, the first lens and second lens comprising, in superposed relation, a linear polarizer layer laminated together with a plurality of polymeric layers, the linear polarizer layer having a polarization axis, the first lens and second lens being formed from lens blanks into a desired shape according to the following steps:

(i) heating and pressing the lens blanks separately between a convex member and a concave member at a first pressure;

(ii) ramping the pressure sigmoidally to a higher pressure over a ramping time; and

(iii) maintaining the higher pressure for a time sufficient to allow the lens blanks to conform to the shape of the convex member and concave member; and

(b) placing the first lens and second lens into an eyeglass frame.

1/8

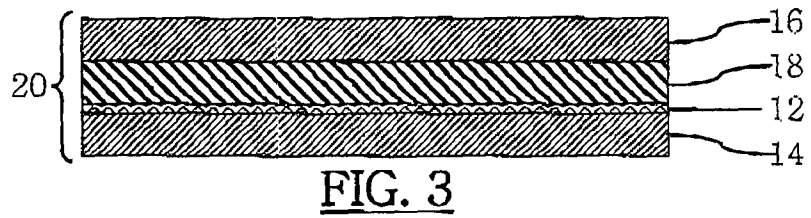
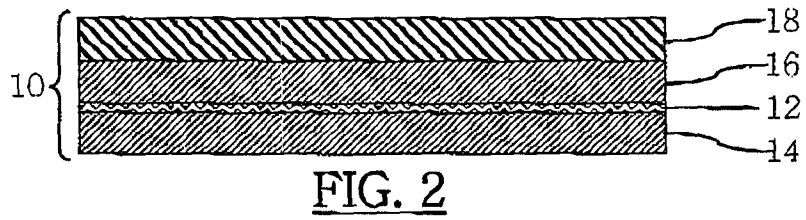
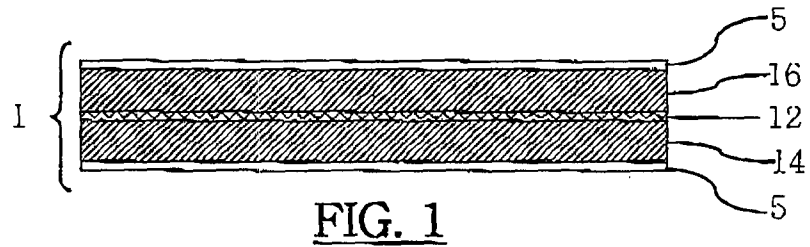

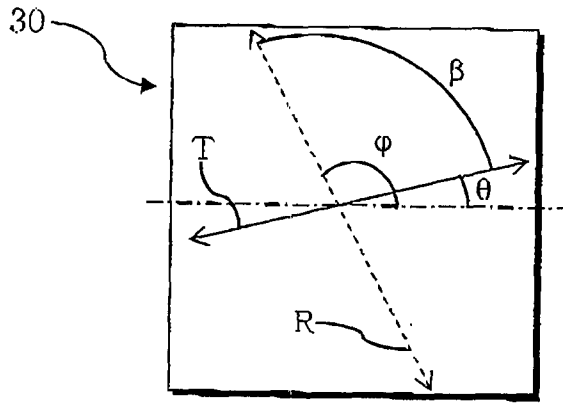

FIG. 4

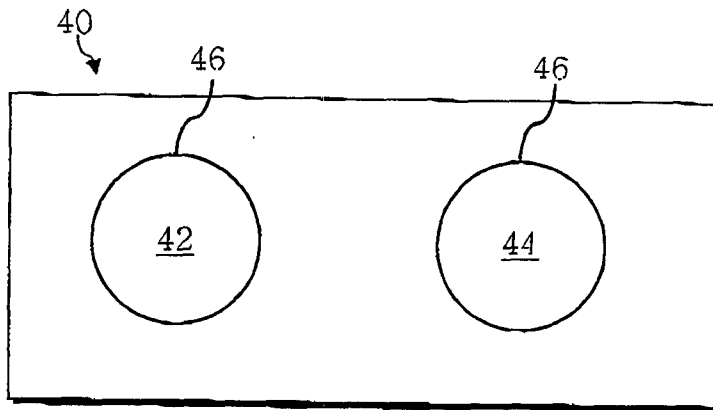

FIG. 5

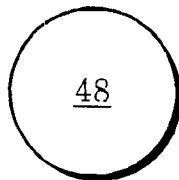

FIG. 6

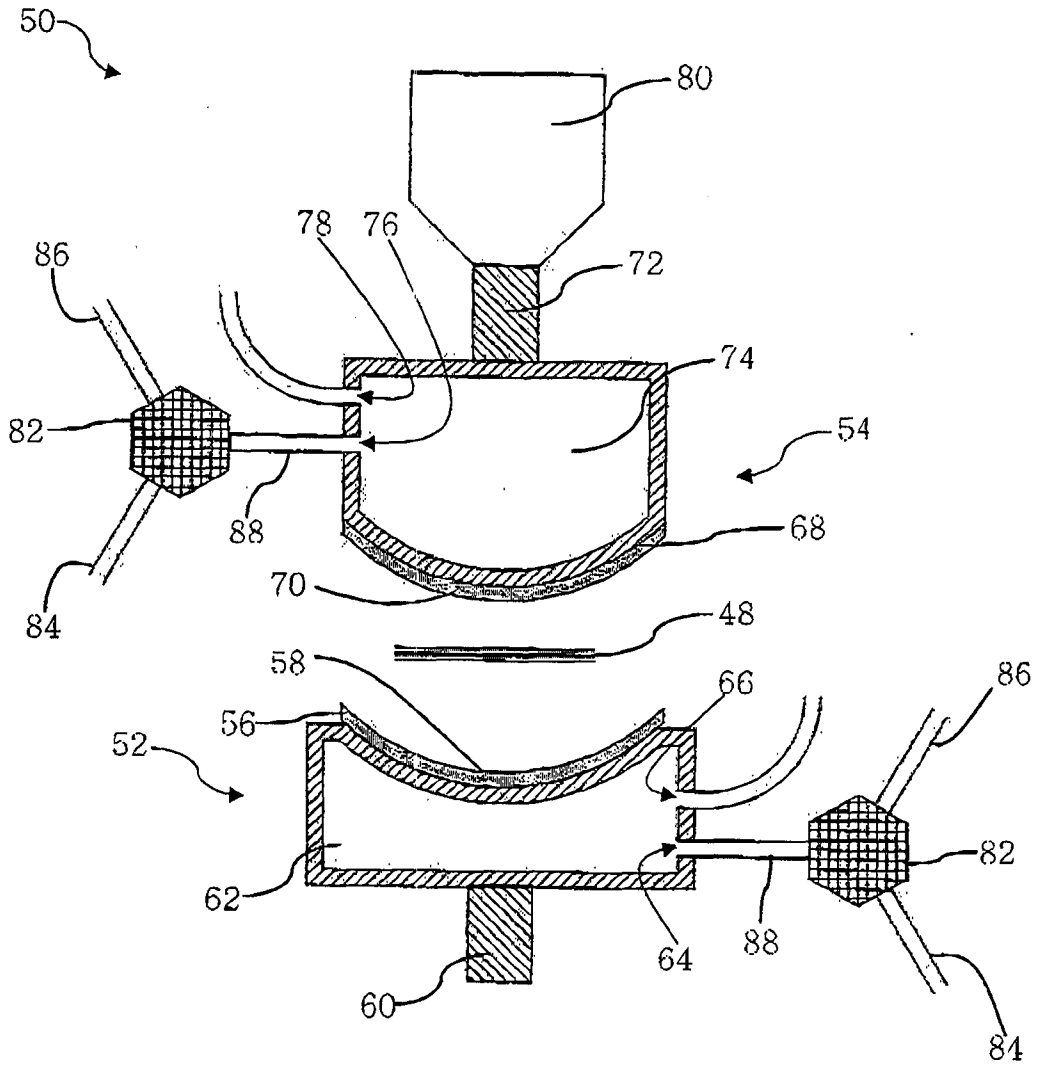

FIG. 7



4/8

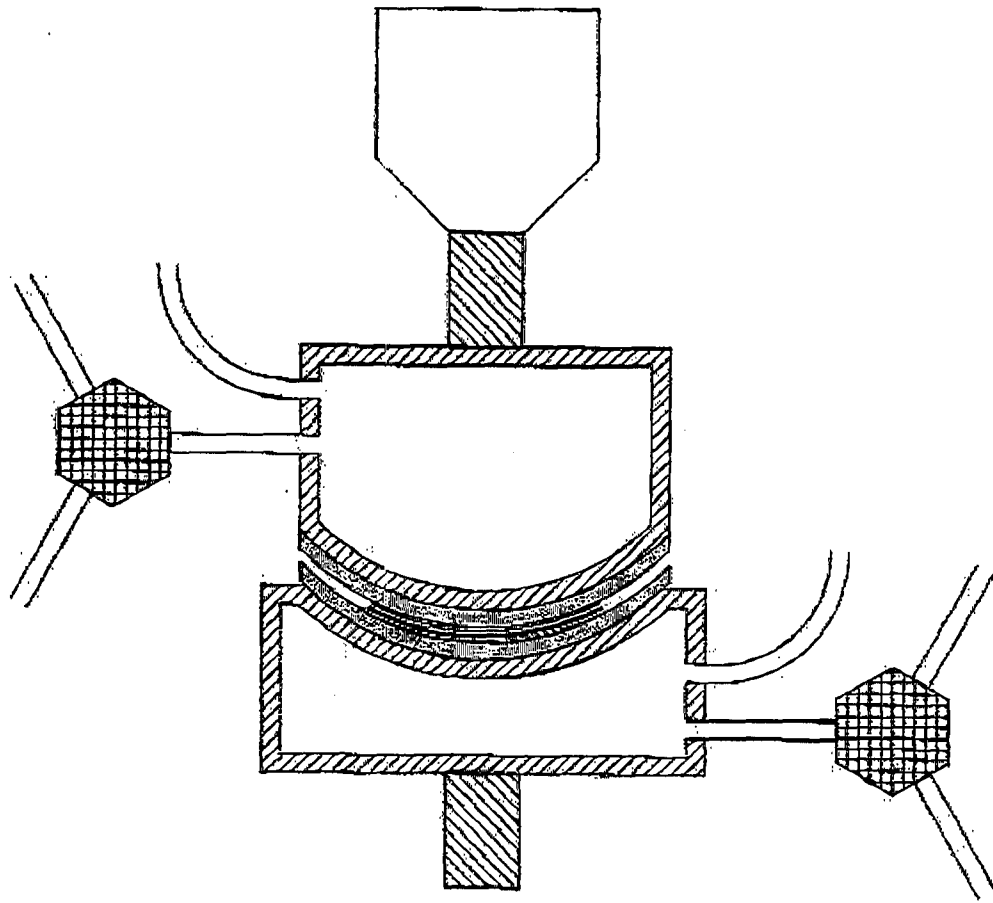

FIG. 8

5/8

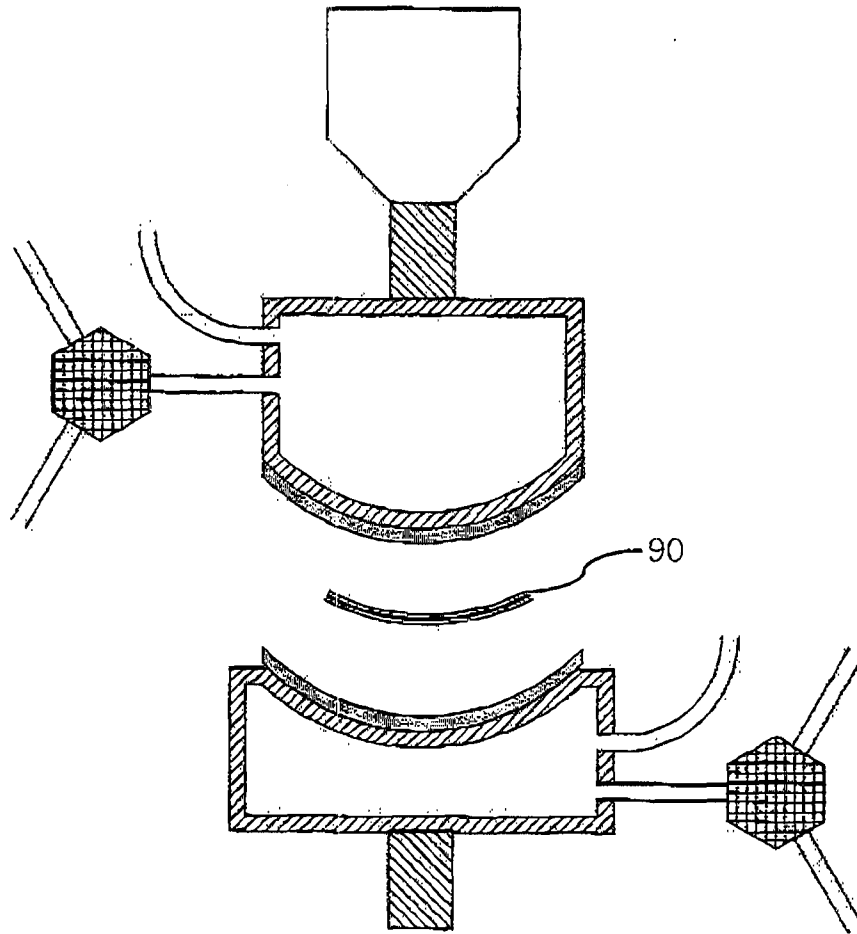

FIG. 9

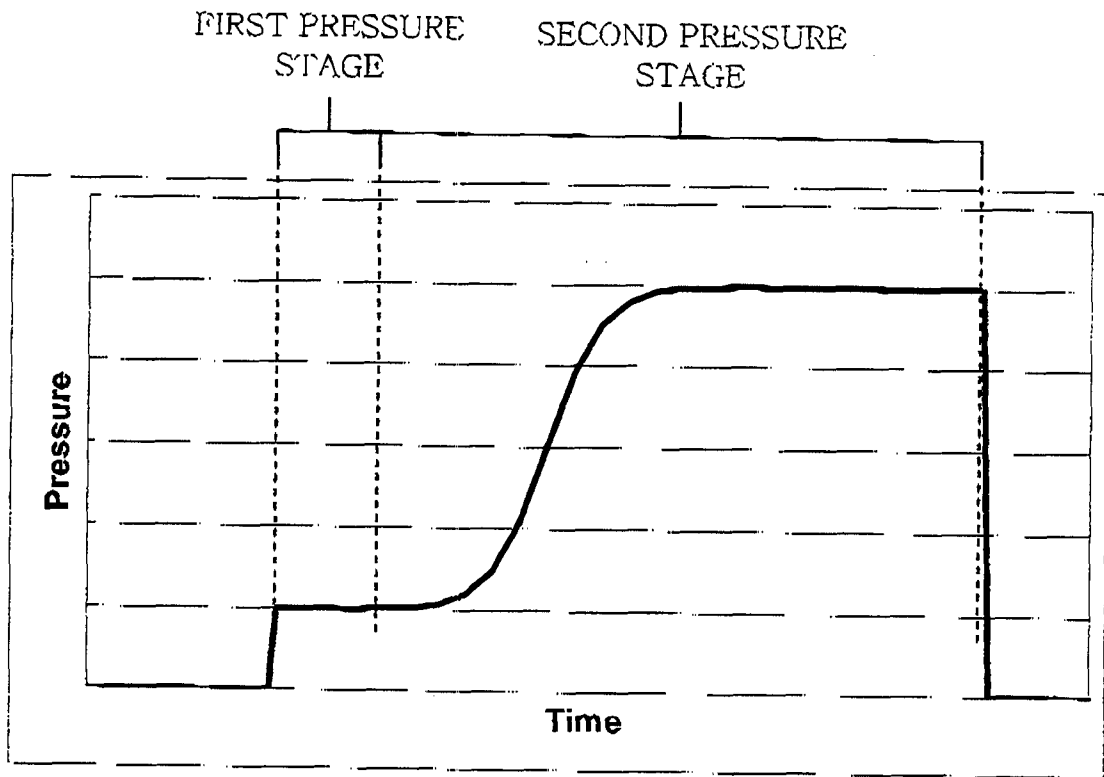
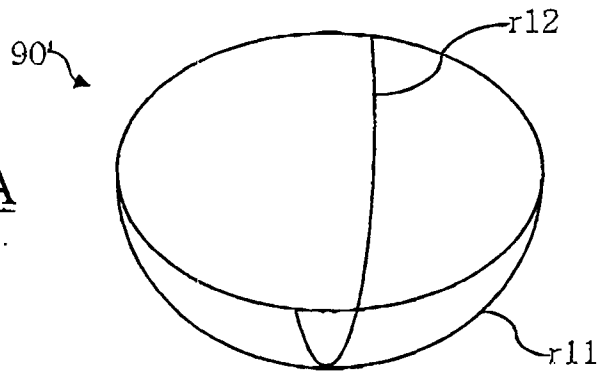

FIG. 10

7/8

FIG. 11A



Spherical:  
 $r11=r12$

FIG. 11B

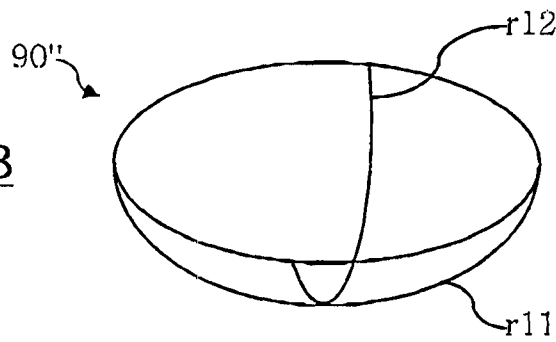

Toroidal:  
 $r11 \neq r12$

FIG. 11C

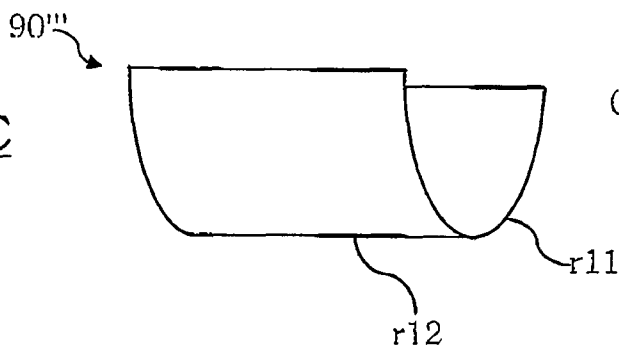

Cylindrical  
 $r12 = 0$

FIG. 12

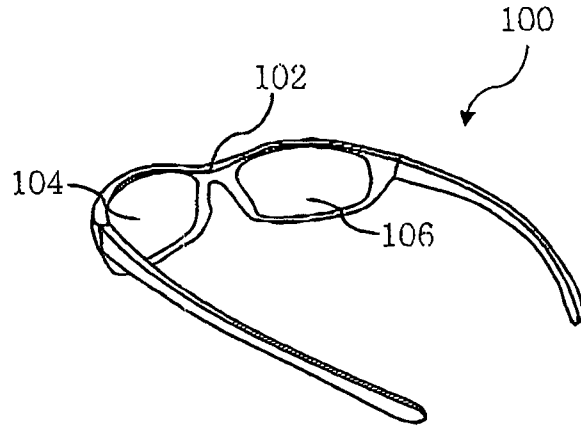

FIG. 13

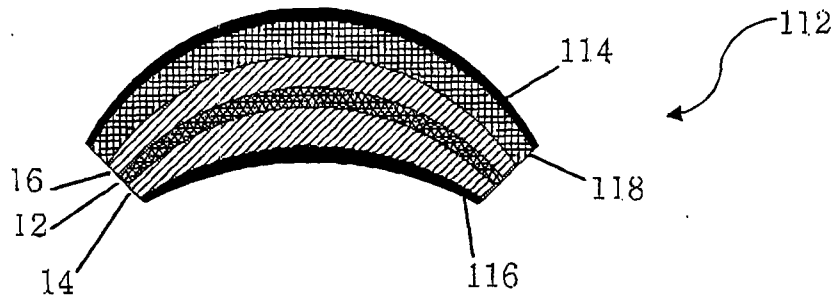
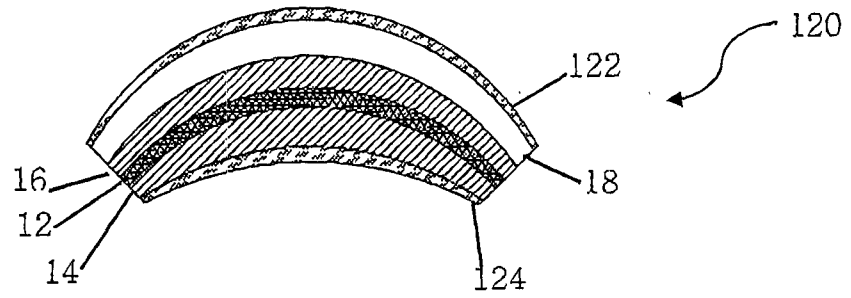

FIG. 14



# INTERNATIONAL SEARCH REPORT

International application No PCT/IB2012/000749
---

<b>A. CLASSIFICATION OF SUBJECT MATTER</b> INV. G02B5/30      B29C43/20      B29D11/00      G02C7/12 ADD.		
According to International Patent Classification (IPC) or to both national classification and IPC		
<b>B. FIELDS SEARCHED</b>		
Minimum documentation searched (classification system followed by classification symbols) G02B B29C B29D G02C		
Documentation searched other than minimum documentation to the extent that such documents are included in the fields searched		
Electronic data base consulted during the international search (name of data base and, where practicable, search terms used)  EPO-Internal, WPI Data		
<b>C. DOCUMENTS CONSIDERED TO BE RELEVANT</b>		
Category*	Citation of document, with indication, where appropriate, of the relevant passages	Relevant to claim No.
Y	WO 97/38345 A1 (POLAROID CORP [US]) 16 October 1997 (1997-10-16) page 8, line 13 - page 10, line 18; figure 1 page 15, line 8 - page 17, line 11; figure 4 page 19, line 1 - page 20, line 21 -----	1-38
Y	US 6 521 146 B1 (MEAD VANDENBERG [US]) 18 February 2003 (2003-02-18) column 2, line 33 - column 3, line 17; figures 1,2 -----	1-38
Y	US 4 199 538 A (WU SHY-HSIEN [US]) 22 April 1980 (1980-04-22) column 3, line 57 - column 4, line 19 ----- -/--	1-38
<input checked="" type="checkbox"/> Further documents are listed in the continuation of Box C. <input checked="" type="checkbox"/> See patent family annex.		
* Special categories of cited documents :		
"A" document defining the general state of the art which is not considered to be of particular relevance	"T" later document published after the international filing date or priority date and not in conflict with the application but cited to understand the principle or theory underlying the invention	
"E" earlier application or patent but published on or after the international filing date	"X" document of particular relevance; the claimed invention cannot be considered novel or cannot be considered to involve an inventive step when the document is taken alone	
"L" document which may throw doubts on priority claim(s) or which is cited to establish the publication date of another citation or other special reason (as specified)	"Y" document of particular relevance; the claimed invention cannot be considered to involve an inventive step when the document is combined with one or more other such documents, such combination being obvious to a person skilled in the art	
"O" document referring to an oral disclosure, use, exhibition or other means	"&" document member of the same patent family	
"P" document published prior to the international filing date but later than the priority date claimed		
Date of the actual completion of the international search	Date of mailing of the international search report	
21 September 2012	02/10/2012	
Name and mailing address of the ISA/ European Patent Office, P.B. 5818 Patentlaan 2 NL - 2280 HV Rijswijk Tel. (+31-70) 340-2040, Fax: (+31-70) 340-3016	Authorized officer  P Theopistou-Bertram	

INTERNATIONAL SEARCH REPORT

International application No  
PCT/IB2012/000749

C(Continuation). DOCUMENTS CONSIDERED TO BE RELEVANT		
Category*	Citation of document, with indication, where appropriate, of the relevant passages	Relevant to claim No.
Y	US 7 854 506 B1 (JOHNSON DAVID A [US] ET AL) 21 December 2010 (2010-12-21) column 3, line 43 - column 4, line 21; figure 5 column 5, line 4 - line 38; figure 7 claim 1 -----	9-14, 27-32,38
Y	WO 97/38344 A1 (POLAROID CORP [US]) 16 October 1997 (1997-10-16) page 8, line 1 - page 9, line 28; figure 1 page 13, line 8 - page 15, line 9; figure 2 page 19, line 6 - line 28 -----	9-18, 27-36
Y	US 2009/079934 A1 (SU KAI C [US] ET AL) 26 March 2009 (2009-03-26)  paragraph [0041] - paragraph [0049]; claim 1; figures 1,2 -----	13, 15-18, 31,33-36
Y	US 6 554 421 B1 (BILLARD ETIENNE [FR] ET AL) 29 April 2003 (2003-04-29) column 6, line 32 - line 39; figure 3 column 7, line 11 - column 8, line 17; figure 5 -----	16,17, 34,35,38

# INTERNATIONAL SEARCH REPORT

Information on patent family members

International application No PCT/IB2012/000749
---

Patent document cited in search report	Publication date	Patent family member(s)	Publication date	
WO 9738345	A1	16-10-1997	AU 2435197 A	29-10-1997
			US 5751481 A	12-05-1998
			WO 9738345 A1	16-10-1997
-----				
US 6521146	B1	18-02-2003	AU 3383100 A	14-09-2000
			BR 0008518 A	13-02-2002
			CA 2364139 A1	31-08-2000
			CN 1345267 A	17-04-2002
			EP 1178885 A1	13-02-2002
			IL 145042 A	18-12-2005
			JP 4116769 B2	09-07-2008
			JP 2002537155 A	05-11-2002
			US 6162376 A	19-12-2000
			US 6521146 B1	18-02-2003
			US 2003146526 A1	07-08-2003
WO 0050222 A1	31-08-2000			
-----				
US 4199538	A	22-04-1980	NONE	
-----				
US 7854506	B1	21-12-2010	US 7854506 B1	21-12-2010
			US 2011085237 A1	14-04-2011
			US 2012147466 A1	14-06-2012
			WO 2011050176 A2	28-04-2011
-----				
WO 9738344	A1	16-10-1997	AU 2435097 A	29-10-1997
			EP 0891575 A1	20-01-1999
			JP 2000508436 A	04-07-2000
			US 5805336 A	08-09-1998
			WO 9738344 A1	16-10-1997
-----				
US 2009079934	A1	26-03-2009	AU 2008304553 A1	02-04-2009
			CA 2700548 A1	02-04-2009
			CN 101932435 A	29-12-2010
			EP 2203300 A1	07-07-2010
			US 2009079934 A1	26-03-2009
			WO 2009042660 A1	02-04-2009
-----				
US 6554421	B1	29-04-2003	AU 1509100 A	19-06-2000
			EP 1135711 A1	26-09-2001
			FR 2786885 A1	09-06-2000
			US 6554421 B1	29-04-2003
			WO 0033123 A1	08-06-2000
-----				



# INTERNATIONAL SEARCH REPORT

International application No.  
PCT/IB2012/000749

## Box No. II Observations where certain claims were found unsearchable (Continuation of item 2 of first sheet)

This international search report has not been established in respect of certain claims under Article 17(2)(a) for the following reasons:

1.  Claims Nos.:  
because they relate to subject matter not required to be searched by this Authority, namely:
  
2.  Claims Nos.:  
because they relate to parts of the international application that do not comply with the prescribed requirements to such an extent that no meaningful international search can be carried out, specifically:
  
3.  Claims Nos.:  
because they are dependent claims and are not drafted in accordance with the second and third sentences of Rule 6.4(a).

## Box No. III Observations where unity of invention is lacking (Continuation of item 3 of first sheet)

This International Searching Authority found multiple inventions in this international application, as follows:

see additional sheet

1.  As all required additional search fees were timely paid by the applicant, this international search report covers all searchable claims.
2.  As all searchable claims could be searched without effort justifying an additional fees, this Authority did not invite payment of additional fees.
3.  As only some of the required additional search fees were timely paid by the applicant, this international search report covers only those claims for which fees were paid, specifically claims Nos.:
4.  No required additional search fees were timely paid by the applicant. Consequently, this international search report is restricted to the invention first mentioned in the claims; it is covered by claims Nos.:

### Remark on Protest

- The additional search fees were accompanied by the applicant's protest and, where applicable, the payment of a protest fee.
- The additional search fees were accompanied by the applicant's protest but the applicable protest fee was not paid within the time limit specified in the invitation.
- No protest accompanied the payment of additional search fees.

**FURTHER INFORMATION CONTINUED FROM PCT/ISA/ 210**

This International Searching Authority found multiple (groups of) inventions in this international application, as follows:

1. claims: 1-8, 19-26, 37

Method for making a formed lens by obtaining a lens blank comprising a polarizer layer laminated with polymeric layers, heating and pressing the lens blank between a convex and a concave member and increasing the pressure to form a curved lens.

---

2. claims: 9-14, 27-32

Method for making a formed lens by obtaining a lens blank comprising a polarizer layer laminated with polymeric layers, heating and pressing the lens blank between a convex and a concave member and increasing the pressure to form a curved lens, wherein one of the polymeric layers is an optical wave retarder with its fast axis aligned at certain angle to the polarizer axis.

---

3. claims: 15-18, 33-36

Method for making a formed lens by obtaining a lens blank comprising a polarizer layer laminated with polymeric layers, heating and pressing the lens blank between a convex and a concave member and increasing the pressure to form a curved lens, wherein the concave and the convex members are having radii of curvature to produce a specific shape of lens.

---

4. claim: 38

Method for making eyewear by obtaining a first lens and a second lens, the lenses formed by lens blanks comprising a polarizer layer laminated with polymeric layers, heating and pressing the lens blanks between a convex and a concave member and increasing the pressure to form the first and second lenses and placing them into an eyeglass frame.

---