

(No Model.)

4 Sheets—Sheet 1.

C. M. JARVIS.

MACHINE FOR GRINDING COCKS AUTOMATICALLY.

No. 521,980.

Patented June 26, 1894.

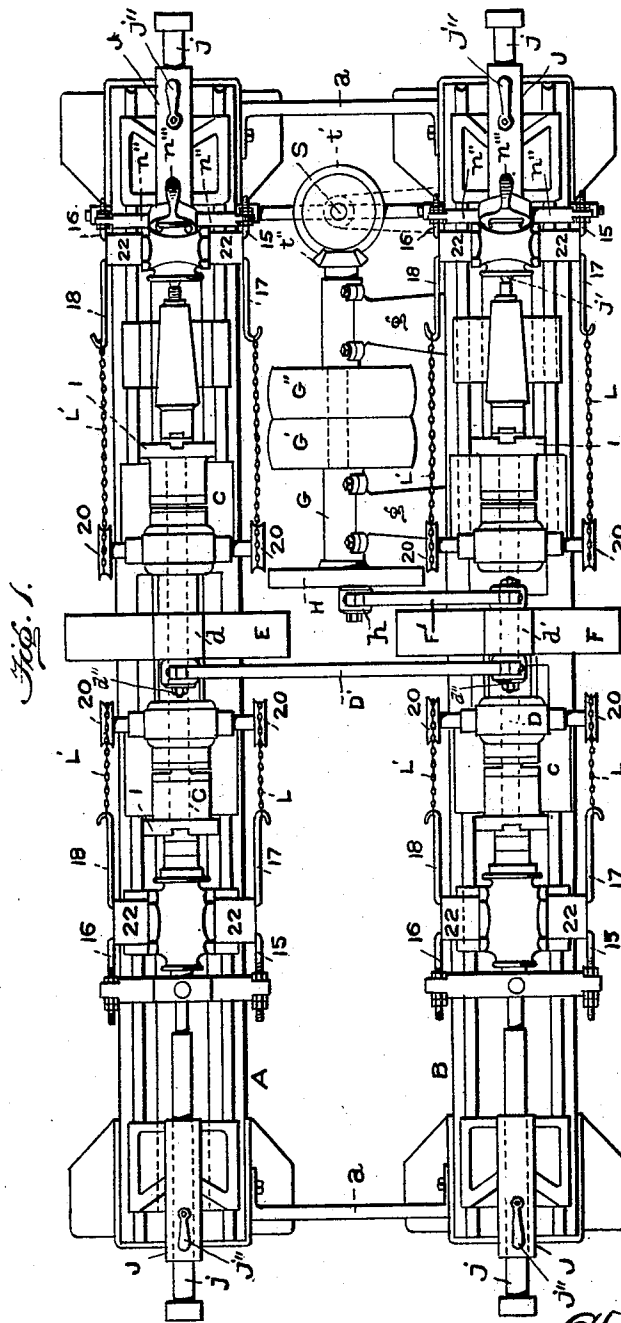

Fig. 1.

Witnesses:

Wm. C. Fashier
H. J. Bunker

Chas. M. Jarvis.
 Inventor.

By Edson Bees.
 Attorneys

C. M. JARVIS.

MACHINE FOR GRINDING COCKS AUTOMATICALLY.

No. 521,980.

Patented June 26, 1894.

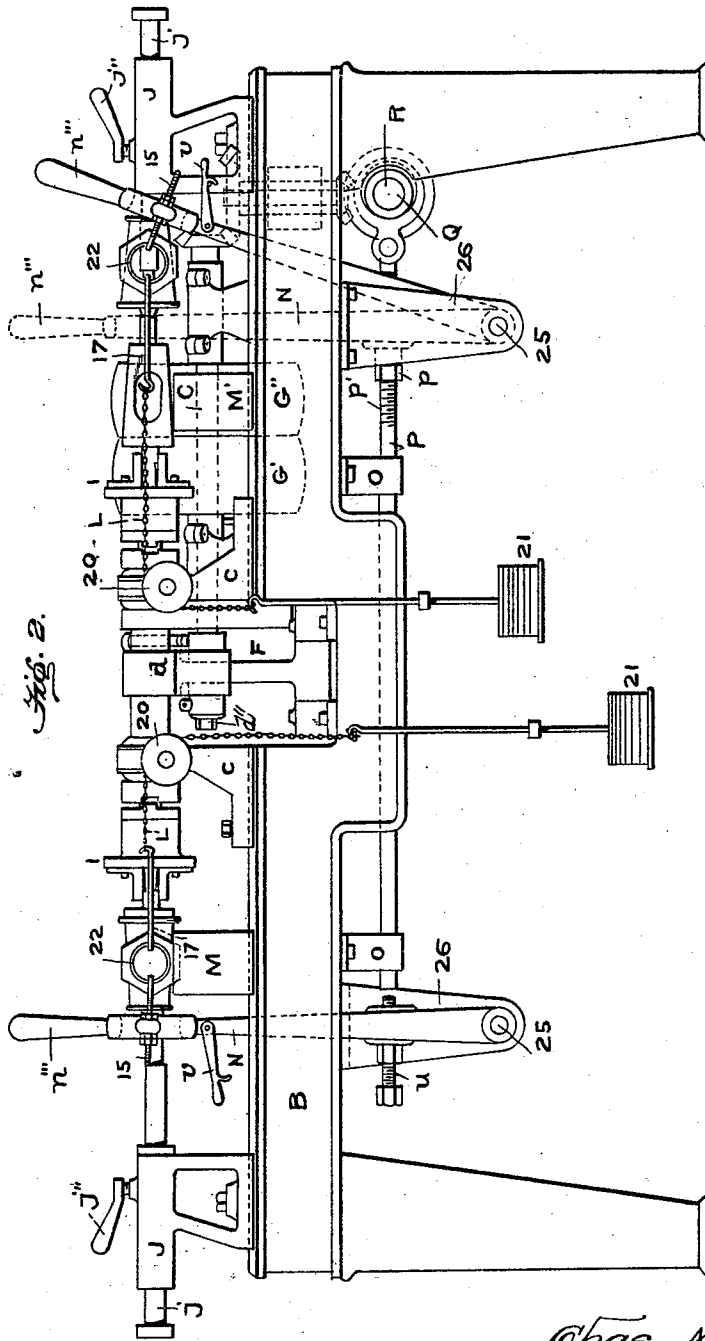

Fig. 2.

Chas. M. Jarvis.
Inventor.

Witnesses:
J. O. Dashiell
H. J. Rowland

By *Edson Bros.*
Attorneys

C. M. JARVIS.

MACHINE FOR GRINDING COCKS AUTOMATICALLY.

No. 521,980.

Patented June 26, 1894.

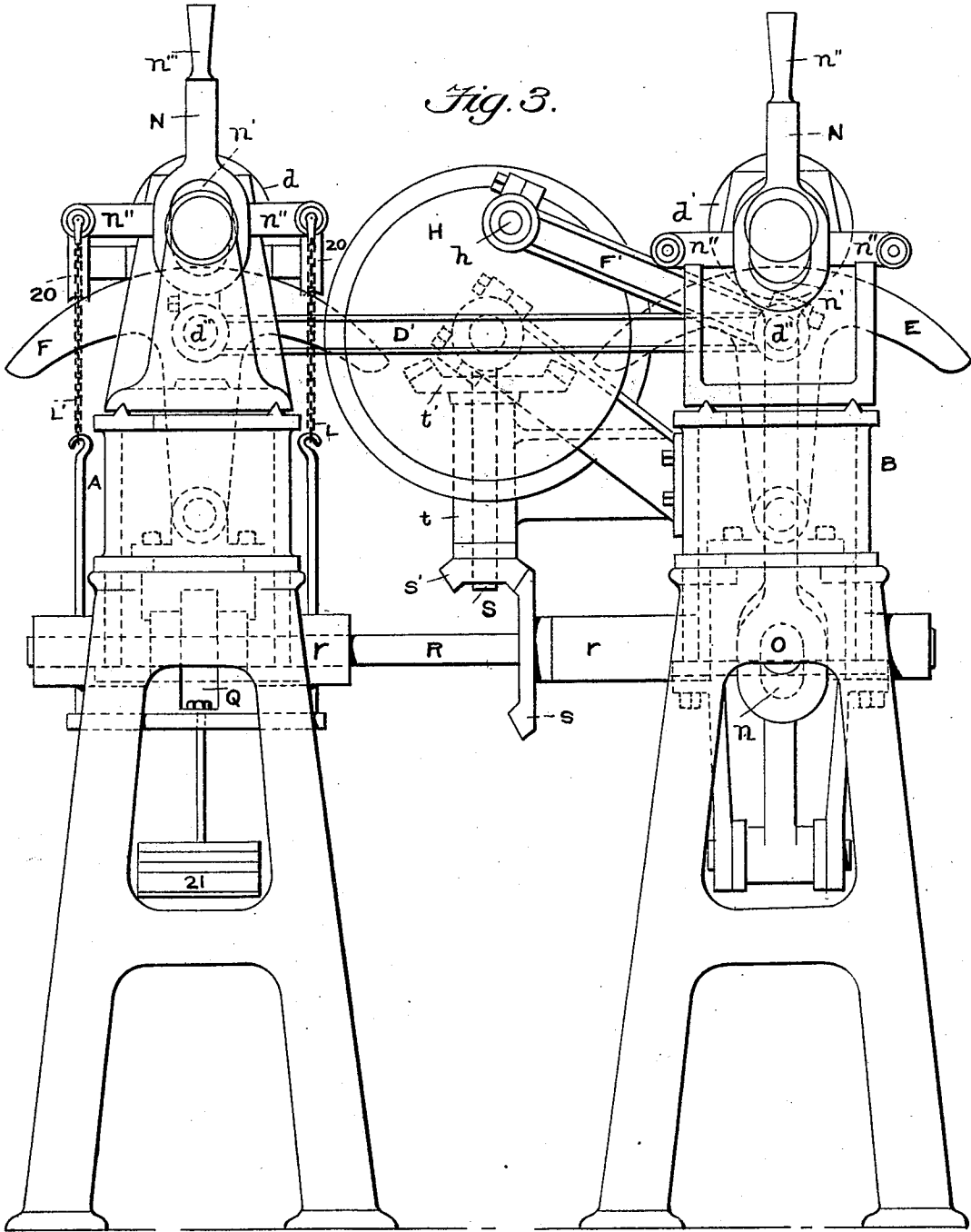

Fig. 3.

Witnesses:

Wm. D. Fisher
H. A. Benson

Chas. M. Jarvis.
 Inventor.

By *Edron Bros.*
 Attorneys

C. M. JARVIS.

MACHINE FOR GRINDING COCKS AUTOMATICALLY.

No. 521,980.

Patented June 26, 1894.

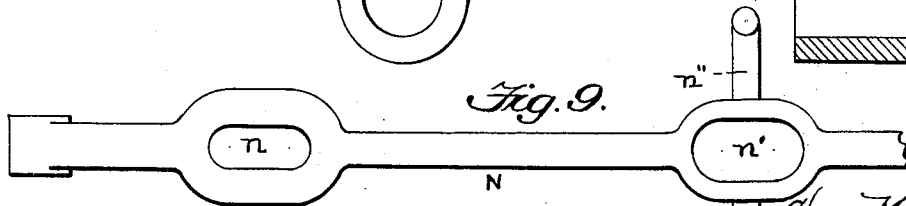
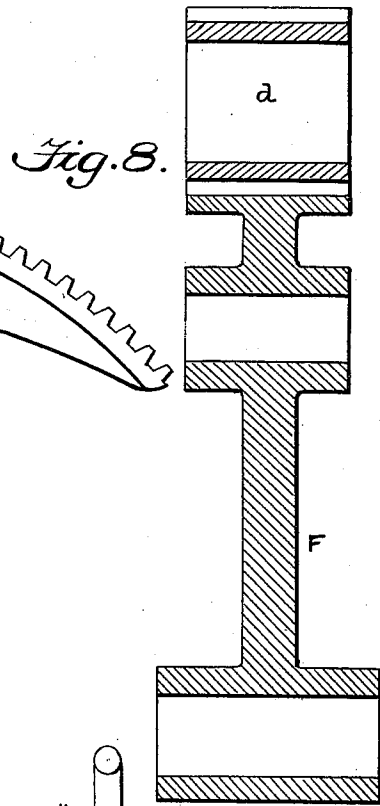
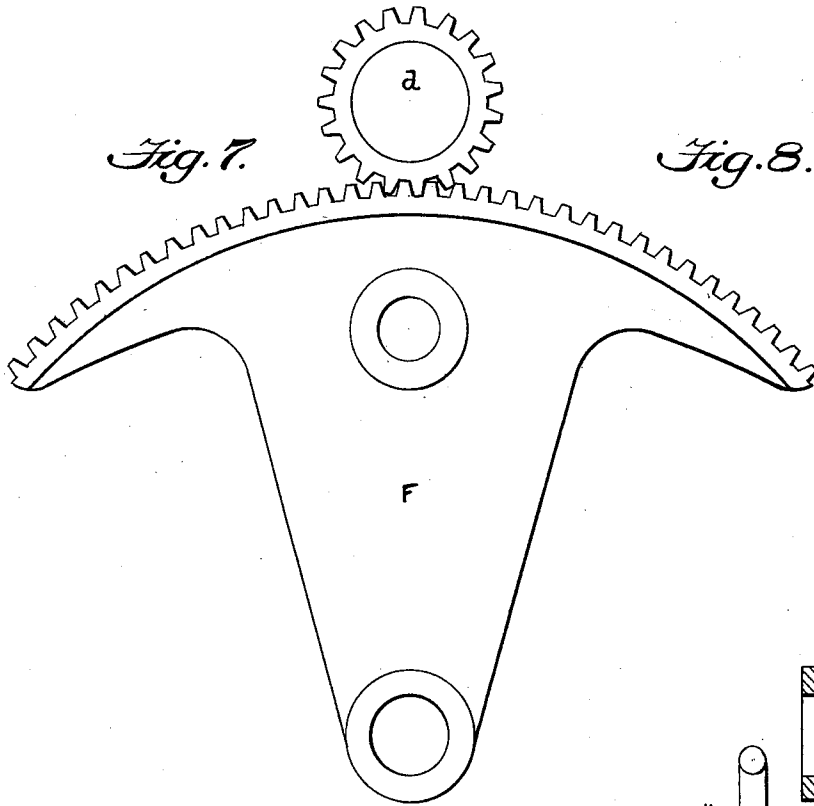
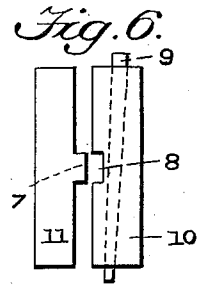
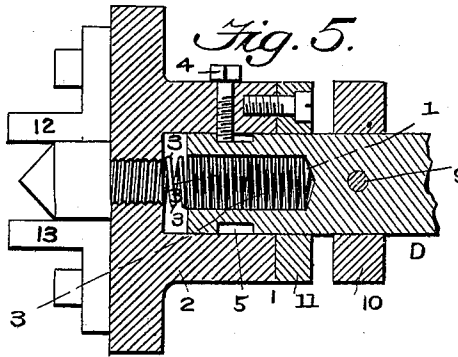
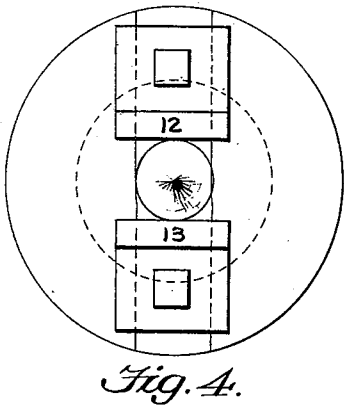

Witnesses:

Wm. C. Ashlee
H. A. Bernhard

Chas. M. Jarvis.
 Inventor.
 By *Edson Birds*
 Attorneys

UNITED STATES PATENT OFFICE.

CHARLES M. JARVIS, OF ERIE, PENNSYLVANIA, ASSIGNOR OF ONE-HALF TO
THE HAYS MANUFACTURING COMPANY, OF SAME PLACE.

MACHINE FOR GRINDING COCKS AUTOMATICALLY.

SPECIFICATION forming part of Letters Patent No. 521,980, dated June 26, 1894.

Application filed January 4, 1894. Serial No. 495,688. (No model.)

To all whom it may concern:

Be it known that I, CHARLES M. JARVIS, a citizen of the United States, residing at Erie, in the county of Erie and State of Pennsylvania, have invented certain new and useful Improvements in Machines for Grinding Cocks Automatically; and I do hereby declare the following to be a full, clear, and exact description of the invention, such as will enable others skilled in the art to which it appertains to make and use the same.

My invention relates to a machine for automatically grinding cocks, and the object that I have in view is to so combine a series of grinding mechanisms with a single driving mechanism that a series of four cocks can be operated on at one and the same time, each grinding mechanism being so constructed that it can be stopped, started and controlled at the will of a single operator, without interference or hinderance from either of the other grinding mechanism so that the operator can inspect either of the cocks and if it is finished, take the same from the machine and replace it with another cock, without stopping the operation of grinding the remaining cocks in the machine, whereby the operator is required to attend to the four pieces of work in the machine and can accomplish more work in a given time than by other machines or processes known to me.

With these ends in view, my grinding mechanism consists in the combination with a driving shaft, of a spindle geared with said shaft and arranged to be driven continuously thereby in a manner to rotate the spindle back and forth one and a quarter revolutions to each rotation of the driving shaft, a chuck carried by the spindle and coacting with a tail stock to support and rotate the plug of the cock to be ground, a shell-sustaining mechanism for holding the shell of the cock under tension and in position to be adjusted upon the plug to which rotary motion back and forth on its axis is imparted by the chuck and spindle, and mechanism operated by the driving shaft for imparting to the shell-holding mechanism a reciprocating motion in order to adjust the shell onto the plug and withdraw the shell from the plug at certain intervals in order to free the sand from between the shell and

plug, whereby the plug has imparted to it an axial rotary back and forth motion and the shell has a reciprocating motion in line with the plug to effect the proper grinding of the seat in the shell and to so furnish the plug as to properly fit said seat in the shell without producing any grooves or uneven surfaces in the plug or shell. A series of these grinding mechanisms are embodied in my invention for the purpose of operating a number of cocks at one and the same time, and said series of grinding mechanisms are so combined with a single driving shaft that the spindles are continuously rotated thereby in the manner described while the plug-holding chuck and shell sustaining mechanism of each of the series of grinding mechanisms can be thrown out of gear in order to permit of the removal of the finished cock and the insertion of a new cock to be ground without interference from either of the other grinding mechanisms which can remain in operation while the removal and insertion of the cocks is being effected in the grinding mechanism so arrested or thrown out of gear, each of the shell-sustaining mechanisms being so arranged that they can be adjusted manually by the operator for the purpose of inspecting the work at any time to ascertain the condition and progress of the grinding operation

My invention further consists in the peculiar mechanism by which the power from the driving shaft is transmitted to the chuck spindles; in the peculiar form of chuck and its clutch mechanism by which the act of inserting the plug in the chuck serves to clutch the latter to the spindle and make the chuck fast therewith; in the novel form of the shell-holding devices which enables the shell to be manually adjusted away from the plug at any stage of the operation of grinding in order to inspect the work; and in the novel mechanism by which automatic reciprocating motion is imparted to the shell-sustaining devices.

The invention further consists in the novel combination of devices and in the peculiar construction and arrangement of parts which will be hereinafter fully described and particularly pointed out in the claims.

I have illustrated the preferred embodi-

ment of my quadruplex cock grinding machine in the accompanying drawings, forming a part of this specification, and in which—

Figure 1 is a top plan view of my machine.
 5 Fig. 2. is a side elevation. Fig. 3 is an end elevation. Figs. 4 and 5 are respectively a face view and a longitudinal sectional view, on an enlarged scale, of my chuck, the clutch and spindle being shown by Fig. 5. Fig. 6
 10 is a detail view of the clutch, in side elevation. Figs. 7 and 8 are detail views of the oscillating segment, and the rotary pinion adapted to be fixed to the spindle, forming a part of the transmitting mechanism between
 15 the driving shaft and one of the spindles, and Fig. 9 is a detail view of one of the levers forming a part of one of the shell-sustaining mechanisms.

Like letters and numerals of reference denote corresponding parts in all the figures of the drawings.

I employ two lathe-beds A, B, which are placed side by side, in parallel positions, and which are securely united together by transverse ties, *a*, see Fig. 1, to present a substantial foundation on which the whole operative mechanisms of the machine are contained. On these parallel beds A, B, are mounted or cast the bearings *c* which are disposed near
 25 the middle of each bed, and in the bearings *c* of the bed A is mounted a longitudinal spindle C while in the bearings *c* of the other bed B is mounted another longitudinal spindle D, said spindles being indicated by dotted lines in Fig. 1 and shown by full lines in
 30 Fig. 5, and each spindle being so disposed that the ends thereof project beyond the bearings *c* on both sides to enable each spindle to carry two chucks, one at each end thereof, whereby
 40 the two spindles are adapted to carry and operate the four chucks necessary for the quadruplex grinding mechanisms. These spindles C, D, are provided with driving wheels *d*, *d'*, respectively, which are keyed or otherwise suitably fastened thereto at points
 45 between the bearings *c* on the lathe-beds A, B; and these driving wheels or pinions are arranged to engage with and be driven by the oscillating segments E, F, which are pivotally supported on the lathe-beds below the
 50 spindles C, D in such manner that the arc-shaped surfaces thereof will engage with the wheels or pinions *d*, *d'* in order to rotate the latter and the spindles. These segments have
 55 their shanks pivoted or fulcrumed at their lower ends on suitable supports on the lathe beds so as to swing or oscillate back and forth in a path at right angles across the longitudinal axes of the lathe-beds and the longitudinal
 60 spindles mounted thereon, and said segments are coupled together for simultaneous operation by means of the link D' which is connected by the wrist pins *d''* to the segments which are operated by connections with
 65 the power shaft G. This power shaft is situated between the lathe-beds and journaled in suitable bearings *g* attached to or rigid

with said lathe-beds, and on the shaft are mounted the fast and loose driving pulleys G', G'', see Fig. 1. On one end of this shaft
 70 is fixed a disk, H, which rotates or turns with the shaft, and on this disk is provided a wrist pin *h* to which is connected one end of a pitman F', the other end of which pitman is connected to the wrist-pin *d''* of one of the
 75 oscillating segments, F, whereby the power of the driving shaft is transmitted through the pitman to one of the oscillating segments and the latter in turn operates the other segment through the link D' so that the two segments
 80 turn the gears and the spindles simultaneously. The arcs of the segments, and the throw or movements of the segments, are so proportioned that the gears and spindles are turned one and a quarter revolutions in one
 85 direction as the segments move in one direction on a half revolution of the eccentric disk and power shaft; and as the power shaft and eccentric disk complete the revolution, the
 90 connected segments are swung in the opposite direction to impart reverse movement to the gears and spindles for one and a quarter revolutions on the completion of the rotation
 95 by the power shaft, so that it will be seen each spindle is rotated alternately for one and a fourth revolution on each turn of the power shaft whereby the reciprocating shell is adapted to engage with the plug, rotating
 100 with the spindle, at different points and obviate the formation of grooves and produce the proper grinding of the plug-seat and the plug.

Each grinding mechanism, of which four are provided in the machine, contemplates the provision for a chuck I, a mechanism for
 105 holding and reciprocating the shell and to enable it to be moved manually by the operator away from the plug for the purpose of inspecting the work, and automatic mechanism for moving the shell-sustaining mechanism
 110 at predetermined intervals for the purpose of freeing the sand or other attrition material from between the shell or plug. The chucks I are carried on the ends of the two
 115 spindles C, D, one at each end thereof, and each chuck is loosely mounted on the spindle and adapted to be automatically clutched thereto by the act of fitting the plug between the chuck and the tail stock. These tail
 120 stocks J, of which four are provided, are mounted on sliding beds at each end of the two lathe beds, opposite to and in line with the chucks on the spindles, as seen by reference to Fig. 1; and each tail stock has a longitudinally-moving rod *j* which has the usual
 125 center *j'*, the rod *j* being clamped in its bearing by a suitable clamp *j''* and the tail stock bed being held on the lathe-bed in the usual or any preferred way. I have illustrated the tail stocks as being of the common construction familiar to those skilled in the art to
 130 which this invention relates, but any suitable form of the tail stock can be used in my grinding machine. The end of the spindle

C or D, is hollowed or bored out, as at 1, to provide a chamber, and the hub 2 of the chuck is fitted loosely on the chambered end of the spindle so as to be movable freely back and forth on the spindle. Between the chuck and the spindle is interposed a spring 3 which bears at one end against the chuck and at its other end against the end wall of the chamber 1, in which chamber the spring is contained; and the chuck is held or confined on the spindle, while capable of free back and forth movement thereon, by means of a pin or screw 4 which is fixed in the hub of the chuck and has its inner end fitted and operating in an angular groove or channel 5 formed in the outside cylindrical surface of the spindle, see Figs. 5 and 6, whereby the chuck is prevented from being forced off the end of the spindle by the pressure of the spring 3 and at the same time the chuck can remain at rest or stationary, that is not partake of the rotary motions of the spindle, except when the chuck is made fast with the spindle, by means of the clutch shown by Figs. 6 and 7. This clutch consists of the fast and loose members 10, 11, one of the members, 11, being applied against the end of the chuck hub 2 and made fast therewith by means of screws or in an equivalent manner, and the fast member 10 of the clutch is made rigid with the spindle so as to rotate therewith at all times, the member 10 being secured preferably by means of a pin or screw 9 which passes through the clutch-member 10 and the spindle, as shown by Fig. 7.

In one of the members, 10, of the clutch are provided the notches or seats 8 and on the other member, 11, of the clutch are provided the lugs or projections 7 which are made to fit or take into the seats 8 when the square or polygonal end of the plug is fitted in the chuck and the latter is forced, along the spindle, against the pressure of the spring, so that the clutch members 10, 11 are engaged and the chuck is made fast to the spindle by the act of fitting the plug in the chuck.

On the front face of the chuck are provided the jaws 12, 13, which are made fast to the chuck-head by bolts or any other suitable means, and these jaws are so disposed relatively to each other that the square or polygonal end of the plug can be fitted and gripped between them, to cause the plug when properly engaged with the tail-stock center j and the chuck, to partake of the rotary back and forth motions imparted to the spindle by the driving mechanism between the spindle and power shaft.

The mechanism for sustaining and adjusting the shell or body of the cock consists of the lever N, the hook rods 15, 16, connected to the lever and adapted to engage with the cock-shell, and the weighted chains L, L' provided with the hook-rods 17, 18, also adapted to engage with the cock body, the hook-rods of the lever and weighted chains extending in opposite directions from the cock body and

70 serving to suspend or hold the cock body under tension between them. These weighted chains are disposed on opposite sides of the spindle and chuck in a manner not to interfere with the action of the rotary devices, and they pass over guide rollers or pulleys 20 which are suitably journaled on the sides of the standards or bearings *c* on the lathe-bed, and the lower ends of these chains sustain the multiple weights 21, 21, which can be changed or regulated so as to draw the cock-shell or body with more or less force on the plug and to vary the tension or contact between the shell and plug of the cock as may be found most desirable in the operation of grinding.

The shell or body of the cock, previous to its introduction in the machine, is fitted with the short nipples, indicated at 22 in Fig. 1 of the drawings, and these nipples extend in opposite directions from the body or shell so that the hook-rods 15, 16, of the lever and the similar rods 17, 18, of the weighted chains can be engaged with the shell or body of the cock; and to prevent said shell or body from partaking of the rotary motions of the plug when the shell is seated or fitted upon the plug to effect the grinding of the plug and its seat in the shell, I provide the stationary rests M, M', which are erected on the lathe-bed on opposite sides of the spindle, chuck and tail stock, and in such position between and relative to the chuck and tail-stock that the nipples 22 of the shell or body will engage with said rests M, M', when the shell or body of the cock is drawn by the weighted chains upon the plug, as will be readily understood by reference to the drawings.

105 The levers N of the grinding mechanisms are disposed near the ends of the lathe-beds, between the spindles and the tail stocks, see Figs. 1 and 2, and these levers are disposed centrally in relation to the lathe-beds, but they are constructed to enable them to operate in conjunction with the weighted chains and without interference with the tail-stocks. The lever N of one grinding mechanism is shown in detail in Fig. 9 of the drawings, and as will be seen it is constructed near the lower end with an elongated eye or loop *n*, and with a similar elongated loop or eye *n'* near its upper end; and said lever is further provided with the laterally extending arms *n''* and has its upper extremity formed into a handle *n'''*. The lever is arranged in an upright position to extend through the lathe-bed, or between the sides thereof, in such position that the tail-stock is adapted to pass through the upper loop or slot *n'* of the lever, and the hook-rods 15, 16, are connected to the lateral arms *n''* of said lever, the lower extremity of the lever being fulcrumed to a shaft or pin at 25 supported by the pendent arm or arms 26 on the lathe-bed, see Figs. 2 and 3.

130 It will be noted that the two levers N to each lathe-bed are arranged in line with each

other and with the spindle journaled on the lathe-bed, and through the lower slots n of right hand levers passes the endwise movable rod, the rod for the levers N on the right hand lathe-bed being shown at O in Figs. 1, 2, and 3 and the rod for the left hand lathe-bed being indicated at P in Figs. 1 and 3. These rods O, P are reciprocated positively by the cams or eccentrics Q , Figs. 2 and 3 which are operated by connection with the power shaft, and these rods O, P serve to impart oscillating motion to the series of four levers N so that the levers are automatically moved at the tail-stocks a limited distance, say three-eighths of an inch, which movement of the levers is sufficient to pull upon the weighted chains and withdraw the cock bodies or shells from off the plugs in order to free or release the sand from between each body and its plug and enable fresh sand to be supplied thereto according as the judgment of the attendant may dictate. The eccentrics Q, Q are carried by a transverse shaft R which extends across from one lathe-bed to the other, and which is journaled in suitable bearings r on the lathe-beds; and on the middle of this shaft is keyed or fastened a bevel gear, s , which meshes with a smaller bevel gear s' on the lower end of an upright shaft S . This latter shaft is journaled in a vertical bearing t suitably connected or fastened to one of the lathe-beds, see Fig. 3, and the upper end of said vertical shaft is geared, through intermeshing bevel gears t', t'' , to one end of the power shaft, the bevel gear t' and s being of greater diameter than the bevel gears t'' and s' with which they respectively intermesh in order that the rods O, P , may be reciprocated once in every four revolutions of the spindles and their chucks. The rods O, P , are guided in suitable pendent brackets o on the lathe-beds, and to the rods O, P , are connected the yokes or straps which encompass the eccentrics Q and by which the reciprocating movements are imparted to the rods. The right hand lever N is connected with its reciprocating rod by means of nuts p, p , which are fitted on the threaded portion p' of the rod and which nuts impinge or bear against the lever which, it will be noted, is drawn normally against the nuts by the weighted chains when the latter and the lever are connected by the hook rods to the shell or body of the cock, for operation. The left hand levers are each arranged for operation by the opposite end of the endwise movable rod by having an adjustable threaded stem u attached thereto and arranged in the path of the free end of the endwise movable rod, the nuts and the stem being adjustable relatively to the endwise movable rods so that the throw or movement of the whole series of levers can be regulated and varied according to the extent of movement it is desired to impart to the shells or bodies of the cocks in order to withdraw them from and force them upon their respective plugs. It will be noted that the weighted chains of the right-hand levers

serve to draw the levers through the cock-body or shell, toward the right hand chuck and plug, and the left hand chains serve to draw the corresponding left hand levers toward the left hand chucks; and that the endwise movable rods O, P , actuate the levers automatically at certain intervals to withdraw each shell from its plug for a limited distance, which distance or movement can be regulated or varied by adjusting the nuts or threaded spindles of the levers, but at the same time each lever can be operated by hand to wholly withdraw the body or shell from its plug, in which case the weighted chains move or give to its respective lever, whereby the operator can inspect the work to ascertain its condition and progress without stopping the rotation of the chuck and plug, in which condition the lever and weighted chains can be locked, as by the pivoted catch v , so that the plug can be removed from the chuck and the finished cock taken from the machine and replaced by another cock to be ground.

Although I have shown and described the transverse shaft R , the eccentrics, the endwise movable rods, and the vertical shaft geared to the power shaft and the transverse shaft as the preferred embodiment of the mechanism for imparting reciprocating motion to the endwise movable rods and to the levers, yet I do not strictly confine myself to the use of this specific mechanism for imparting automatic reciprocating motion to the levers, as I am aware that cams can be arranged to act directly against the levers, to force them positively in one direction and use the weighted chains to draw the levers toward the chucks, said cams being carried by shafts geared to the power shaft.

In Figs. 7 and 8 of the drawings I have shown the oscillating segments and the driving pinions on the spindles C, D , as provided with intermeshing gear teeth, but I can dispense with these noisy gear teeth and drive the pinions by frictional contact with the arc-shaped surfaces of the oscillating segments, as indicated in Figs. 1, 2 and 3 of the drawings in which case the pinion is made or its periphery faced with wood and the arc-shaped surface of the segment is faced with a friction material, such as rawhide, or any equivalent substance, in order to insure the necessary frictional contact between the segment and pinion, to drive the latter. The segment or the pinion may be so supported that they can be adjusted toward each other, to compensate for wear and insure the desired engagement with each other.

This being the construction of my machine, the operation may be described as follows: The upright levers, N , are held or locked by the pivoted catches in position over the tail stocks, and power having been applied to the fast pulley, the power shaft is driven to turn the crank disk and through the pitman and link, the segments and driving pinions are rotated so that the chucks and spindles have

the rotary back and forth motions for one and a quarter revolutions to each half rotation of the shaft. To place a cock in either one of the grinding mechanisms of the machine for grinding the plug and the plug-seat in the shell or body, the plug is first fitted in the chuck so that its polygonal end is confined or gripped between the jaws thereof and the center of the tail stock is then brought up against the other end of the plug to force the chuck endwise on the spindle and cause it to be made fast with the spindle through the action of the clutch, after which the tail-stock center is clamped in place, thus causing the chuck and the plug centered between the spindle. The body or shell of the cock, having the nipples 22 fitted in its opposite sides, is now connected to the hook rods 15, 16 of the lever; the hook rods of the weighted chains are now drawn up and connected to said nipples of the cock-body on the opposite side thereof to the hook rods of the lever; the water and sand applied to the cock-body and to the plug, and finally the pivoted catches are unclasped to release the levers and permit the weighted chains to draw the levers toward the chuck and force the body or shell upon the rotating plug, the nipples of the shell being fitted upon the stationary rests so that the shell will not partake of the rotary motions of the plug. The plug is turned axially in the cock-body back and forth in the manner described, and at certain intervals the lever is forced by the reciprocating mechanism away from the chuck for a very limited distance sufficient to free the sand between the plug and the body of the cock; and this positive limited movement of the lever draws the body or shell and the weighted chains with said lever, after which the chains draw the lever and shell backward and force the plug into the seat in the body or shell for the purpose of continuing the grinding operation of the opposing faces of the plug and shell. The lever can be drawn by hand away from the chuck to raise the chains and withdraw the body from the plug, to permit the attendant to inspect the work at any stage of its operation, and when the grinding is complete, the operator forces the lever backward and locks it in place, thus withdrawing the shell wholly from off the plug, the shell is detached from the rods of the chains and lever, the tail-stock is released, and the plug taken out of the chuck, to be replaced by another cock to be ground.

It will be observed that a series of four cocks can be ground at one time in my machine, and that as each of the grinding mechanisms can be controlled by the hand lever thereof, the work of inspecting and removing the ground cocks can be effected without interfering with the operation of grinding the remaining cocks.

I am aware that changes and alterations in the mechanisms herein shown and described

as an embodiment of my invention can be made without departing from the spirit or sacrificing the advantages of my invention, and I therefore reserve the right to make such modifications as fairly fall within the scope of my invention.

Although I have herein shown and described the machine as constructed to grind a series of four cocks at one time, yet it is evident that I can build the machine on the same principle to grind more than four cocks; hence my invention is not restricted to a machine in which any particular number of cocks can be simultaneously operated on.

Having thus fully described my invention, what I claim as new, and desire to secure by Letters Patent, is—

1. In a machine for grinding cocks automatically, mechanism substantially as described for rotating the plug a complete revolution and fractional part thereof in one direction and an equal rotary motion in the reverse direction, in combination with a lever disposed in axial alignment with said plug-rotating mechanism and provided with means for attachment to one side of a cock-shell or body, a yielding tension device adapted to be connected to the opposite side of the cock-shell or body and serving to normally move the lever toward the plug-rotating devices, and automatic devices to move the lever and the tension device away from the plug-rotating devices at certain intervals, substantially as and for the purposes described.

2. In a machine for grinding cocks automatically, the combination with a spindle carrying a chuck, a tail stock, and mechanism for imparting alternately-reversed rotary motions to said spindle and chuck, of the coacting lever and tension device arranged between the tail stock and said chuck, to move in axial alignment therewith, and each provided with fastenings adapted to connect with the respective sides of the cock-shell or body, and automatic devices for imparting reciprocating motion to said lever and tension device, whereby the cock-shell can be momentarily withdrawn from the plug and returned, by the tension-device, to have proper engagement, under pressure, with said plug, as described.

3. In a machine for grinding cocks automatically, the combination with a spindle carrying a chuck and mechanism for rotating the same, substantially as described, of a lever having means for attachment to a shell or body, the tension devices also having means for attachment with the shell or body, and mechanism for automatically moving the lever and tension devices a limited distance away from the chuck at certain periods, substantially as and for the purposes described.

4. In a machine for grinding cocks automatically, the combination with means for giving to the plug alternately-reversed rotary motions of equal period, of a shell-sustaining device embodying a movable lever to be connected to one side of a shell and a tension device to

be connected to the opposite side of the shell, and which parts coact with the shell to hold the same under tension upon the plug and enable the shell to be withdrawn wholly from the plug, and mechanism for imparting to the shell-sustaining devices a limited reciprocating motion to partially withdraw the shell from the plug at certain regular periods, substantially as and for the purposes described.

5. In a machine for grinding cocks automatically, the combination of the spindles each provided with the chucks, the tail-stocks disposed oppositely to the chucks, a driving mechanism common to said spindles and geared to impart alternately-reversed rotations thereto for equal periods, the shell-sustaining lever and tension device provided with means for engaging with the respective sides of a cock-shell and disposed between each of the chucks and its corresponding tail stock, in axial alignment therewith, and mechanism operated by the driving mechanism and connected with the shell-sustaining levers to impart reciprocating motion thereto in line with the spindles and tail stocks, substantially as and for the purposes described.

6. In a machine for grinding cocks automatically, the combination of the chuck-carrying spindle, the tail stocks in line with said spindles, a driving mechanism geared to said spindle to impart alternate-reversed rotary motions thereto, the coacting lever and tension device between each chuck and its tail-stock and provided with means for engaging opposite sides of the cock-shell, a vertical shaft geared to said driving mechanism, a cam-shaft geared to the vertical shaft, and connections between the levers and said cam-shaft to impart reciprocating motion to each lever at certain periods during the rotation of the corresponding chuck, substantially as and for the purposes described.

7. In a machine for grinding cocks automatically, the combination of the chuck-carrying spindle, a tail-stock, a driving mechanism for imparting alternately-reversed rotary motions to the spindle, the coacting lever and tension device having means for engagement with the cock-shell, and the transmitting automatic mechanism geared to the driving mechanism and provided with adjustable connections for said vibrating lever to vary the throw or movement thereof, substantially as and for the purposes described.

8. In a machine for grinding cocks automatically, the combination with the chuck-carrying spindles, the tail-stocks therefor, and the driving mechanism geared to said spindles, of the coacting lever and tension device between each chuck and its tail-stock and having means for engaging with opposite sides of the cock-shell, the vertical shaft geared to the driving mechanism, the transverse cam-shaft geared to said vertical-shaft, and the reciprocating rods actuated by said cam shaft and having means engaging with

the levers to vibrate the same, for the purposes described, substantially as set forth.

9. In a machine for grinding cocks automatically, the combination with the parallel chuck-carrying spindles of a driving shaft between said spindles, the oscillating segments each pivoted at one end and having its arch-shaped surface geared to one of the spindles, connections between the driving shaft and the segments to impart oscillating motion simultaneously thereto, a tail stock opposite to each chuck, a coacting lever and tension device constituting a shell-sustaining device between each chuck and its tail stock, and means for automatically reciprocating each lever and its tension device, substantially as and for the purposes described.

10. The combination with a recessed spindle, and a tail stock in line therewith, of a slidable non-rotatable chuck fitted loosely on said recessed end of the spindle, a spring seated in said recessed spindle and normally pressing against the slidable chuck, and means for making the clutch fast to the spindle by the adjustment of the work between the tail stock and the slidable chuck, substantially as and for the purposes described.

11. The combination with a spindle, and a tail stock in alignment therewith, of a non-rotatable chuck loosely fitted on said spindle and slidably connected thereto, a spring normally acting on the chuck to force the same to the limit of adjustment permitted by the slidable connection between the chuck and spindle, and a clutch having one member fast to the spindle and the other member fast to the slidable chuck and said members being spaced to engage with each other by the endwise movement of the chuck as the work is adjusted between the chuck and tail stock, substantially as and for the purposes described.

12. The combination of a spindle, a slidable chuck fitted loosely thereon and connected by a slide joint therewith to permit the chuck to have a limited movement on the spindle and to enable the latter to rotate without rotating the chuck, a clutch having its members fast with the spindle and the chuck, respectively, and a spring interposed between the spindle and the chuck, for the purposes described, substantially as set forth.

13. The combination of a spindle provided with a hollow spring-seat in its end, a slidable chuck fitted loosely upon said end of the spindle and connected by a slide joint therewith, a spring seated in the hollow end of the spindle and against the chuck, and the clutch having one member fast with the loose chuck and the other member fast with the spindle, substantially as and for the purposes described.

14. The combination with a spindle, a chuck, and a tail stock, of the slotted lever arranged in line with the spindle and adapted to be fitted on the tail stock, devices for con-

necting said lever with a shell or body of the cock, the weighted chains guided by suitable rollers and having means to engage with the shell or body of the cock, and the fixed rests
 5 disposed to engage with the shell or body and prevent it from rotating on the same as the shell is fitted upon the plug, substantially as and for the purposes described.

15. In a machine for grinding cocks auto-
 10 matically, the combination with the spindles, the chucks, and the tail stocks, of the levers and weighted chains arranged to sustain the shells or bodies of the cocks in operative po-
 15 sitions relative to the plugs between said chucks and tail stocks, the transverse shaft having the cams for imparting limited move-
 20 ment to the series of levers during certain periods of the grinding operations, a power shaft, and countershaft geared to the power shaft and to the transverse shaft, substan-
 tially as and for the purposes described.

16. In a machine for grinding cocks auto-
 25 matically, the combination with mechanism for rotating the plugs, of the shell-sustaining devices having the levers, the power shaft, a transverse cam shaft driven through interme-
 diate gearing from said power shaft, reciprocating rods operated by cams on the trans-

verse shaft, and adjustable connections be-
 30 tween said rods and said levers to vary and regulate the throw of the levers and the move-
 ment of the shell-sustaining devices, substan-
 tially as and for the purposes described.

17. In a machine for grinding cocks auto-
 35 matically, the combination with mechanism for imparting alternately reversed rotary mo-
 tions to a series of plugs, of the shell sustain-
 ing devices having the levers, a transverse
 shaft provided with cams or eccentrics, the
 40 reciprocating rods having means for rocking the levers of the shell-sustaining devices and
 arranged to be operated by the cams or ec-
 centrics of the transverse shaft, a power shaft,
 and a countershaft geared to the power and
 45 transverse shafts to actuate the rods and levers at certain periods during the rotations
 of the plug mechanism, substantially as and
 for the purposes described.

In testimony whereof I affix my signature in
 presence of two witnesses.

CHAS. M. JARVIS.

Witnesses:

HENRY A. CLARK,
 JNO. M. GLAZIER.