



HU000028995T2

(19) **HU**(11) Lajstromszám: **E 028 995**(13) **T2****MAGYARORSZÁG**
Szellemi Tulajdon Nemzeti Hivatala**EURÓPAI SZABADALOM**
SZÖVEGÉNEK FORDÍTÁSA(21) Magyar ügyszám: **E 11 728804**(51) Int. Cl.: **F03D 80/00** (2006.01)(22) A bejelentés napja: **2011. 06. 20.**(96) Az európai bejelentés bejelentési száma:
EP 20110728804(86) A nemzetközi (PCT) bejelentési szám:
PCT/EP 11/060219(97) Az európai bejelentés közzétételi adatai:
EP 2603693 A2 **2012. 02. 16.**(87) A nemzetközi közzétételi szám:
WO 12019815(97) Az európai szabadalom megadásának meghirdetési adatai:
EP 2603693 B1 **2016. 04. 13.**

(30) Elsőbbségi adatok: 202010011397 U 2010. 08. 13. DE	(73) Jogosult(ak): Wobben Properties GmbH, 26607 Aurich (DE)
(72) Feltaláló(k): MÜLLER, Johann, 26607 Aurich (DE)	(74) Képviselő: Danubia Szabadalmi és Jogi Iroda Kft., Budapest

(54)

Munkaállvány és lift szélturbinához

Az európai szabadalom ellen, megadásának az Európai Szabadalmi Közlönyben való meghirdetésétől számított kilenc hónapon belül, felszólalást lehet benyújtani az Európai Szabadalmi Hivatalnál. (Európai Szabadalmi Egyezmény 99. cikk(1))

A fordítást a szabadalmas az 1995. évi XXXIII. törvény 84/H. §-a szerint nyújtotta be. A fordítás tartalmi helyességét a Szellemi Tulajdon Nemzeti Hivatala nem vizsgálta.

WORKING PLATFORM AND LIFT FOR WIND TURBINE

The present invention relates to a wind turbine work scaffold according to the preamble of claim 1,
5 having a working platform and a rail which is arranged on the working platform, wherein the rail can be blocked
by means of a blocking element and the blocking element is arranged in a transition region to a lift.

The invention further relates to a wind turbine having at least one wind turbine work scaffold men-
tioned above, a lift and a locking device for a wind turbine.

Work scaffolds of the above-mentioned type are used during the assembly of wind turbines or for ser-
vice operations during the service-life of wind turbines. Specific types of wind turbines only require the tempo-
10 rary presence of work scaffolds on or in a wind turbine, in particular during the construction or disassembly,
whilst with other turbine types, in particular large turbines, one or more work scaffolds are often fixedly in-
stalled. Work scaffolds of the above-mentioned type can also be arranged in the control booth of a wind turbine.
The work scaffolds of specific wind turbines are approached by means of a lift. The access from the lift to the
15 work scaffold of the turbine is produced in a transition region on the work scaffold. If operations have to be
carried out in parallel on a plurality of scaffolds or if the lift is required to travel to the control booth or to return
to the ground, it may be the case during operation that operators remain on the work scaffolds when the lift does
not stop on the platform. For safety reasons, it is absolutely necessary for the transition region of the operating
scaffolds to be blocked by means of a blocking element so that the danger of accidents involving falling can be
20 reduced to the greatest possible extent.

Known devices provide for this purpose locking devices on the rails of working platforms, by means of
which the locking elements on the rails can be locked. However, it is possible in the known devices, as a result
of occurrences of negligence or even intentionally, for the locking element to remain unlocked when the lift
leaves the work scaffold. This is considered to be a disadvantage in the prior art and at the same time perceived
25 to be a serious security loophole.

Document FR 2821613 A1 sets out a lift cabin with a key which is secured to a chain and by means of
which a screen door can be locked and unlocked, wherein the chain is arranged inside the lift. The length of the
chain is sized in such a manner that it is not possible to unlock the screen unless the lift is placed at the correct
height.

30 Document WO 2006/056196 sets out a wind turbine having a base and a tower which is positioned on
the base, wherein the tower has a lift by means of which it is possible to travel back and forth between a ground
level and a work scaffold level.

Document US 5,069,324 discloses a chain lock for shopping trolleys having a front and a rear keyhole,
which are each constructed for receiving a key, wherein with one key in a locking mechanism the other key is
35 released in each case.

Based on this, an object of the present invention is to provide a wind turbine work scaffold, a locking
device which is constructed for this purpose, a lift and a wind turbine, which each provide better security against
accidents involving falling.

The present invention solves the problem addressed with a wind turbine work scaffold of the type men-
40 tioned in the introduction by the scaffold being constructed according to claim 1 having a locking device having

a locking mechanism for receiving a first locking element and a second locking element, wherein the first locking element is connected to the lift and the second locking element is connected to the blocking element and the locking mechanism is constructed for release of one of the two locking elements by means of the locking of the other locking element in each case relative to the locking device.

5 The locking mechanism is constructed in the manner of a deposit locking system. The advantage of the use of a deposit locking system in particular involves such systems being commercially available and, in the case of older work scaffolds which have already been installed, also being able to be retrofitted with extremely little complexity.

10 The invention is based on the recognition that the safety with respect to an unintentional fall through the transition region of the rail of the work scaffold is improved in the most effective manner by removal of the lift from the work scaffold without previously securing the transition region by locking the blocking element relative to the work scaffold being made impossible. This is implemented according to the invention in that in order to unlock the locking device of the work scaffold the first locking element has to be moved into a locking position relative to the locking mechanism of the locking device. However, by the first locking element also
15 being connected to the lift, in particular securely connected in a mechanical manner, in addition to the first locking element, the lift is also in a locking position when the second locking element, which is associated with the blocking element on the work scaffold, is located in a release position. According to the invention, the locking position of the first locking element can be exclusively cancelled by the second locking element being moved into a locking position relative to the locking device. The locking mechanism of the locking device is consequently constructed to always retain either the first locking element or the second locking element in a locking
20 position so that two safety-relevant states are alternately produced. These are, firstly, a locking of the blocking element on the work scaffold in the absence of the lift and, secondly, a presence of the lift on the work scaffold in the release position of the blocking element. A removal of the first locking element and consequently a release of the lift from the work scaffold is not possible when the blocking element is not locked on the work scaffold.
25

 Preferably, the locking mechanism has locking means for alternate positive-locking connection and/or non-positive-locking connection to the first and second locking element. The blocking means preferably have at least one blocking member for positive-locking engagement and/or non-positive locking engagement with the first or second locking element which can be brought out of engagement with the first or second locking element by means of a displacement member which is associated with the other locking element in each case.
30

 The invention is advantageously developed in that the locking mechanism is configured to receive the first locking element in the form of a coin, a profiled and/or contoured flat member, rod or a hollow member. The first locking element is preferably constructed in such a manner that only it can be brought into engagement with the locking mechanism. An operator is consequently prevented from introducing into the locking mechanism an alternative commercially available object which is not fixedly connected to the lift. When the locking
35 element is a coin, this is preferably achieved by the coin being associated with a foreign currency. Possibilities of bypassing use in accordance with safety and provisions are thereby limited.

 Preferably, the second locking element is similarly constructed in the form of a coin, a profiled and/or contoured flat member, rod or a hollow member.

A deposit locking system is intended to be understood to be, for example, a locking system for shopping trolleys or luggage storage devices.

The locking mechanism is preferably arranged inside a housing of the locking device. The housing affords protection against damage and/or improper opening of the locking mechanism in a manner not in accordance with provisions. Furthermore, protection is afforded against the introduction of contamination.

In a preferred embodiment of the work scaffold, the locking mechanism is arranged in a fixed manner in the locking device on the work scaffold, preferably on the rail. An arrangement of the locking mechanism at a height which is convenient for an operator, preferably approximately at waist height, simplifies the operation.

According to another advantageous embodiment of the work scaffold according to the invention, the blocking element is pivotably connected to the rail in a first portion of the transition region to the lift, and the locking mechanism is arranged in a second portion of the transition region to the lift opposite the first portion. The blocking element is preferably a rod, a chain or a door. The selection of the blocking element is preferably based on the size of the work scaffold. As an alternative to a pivotable arrangement of the blocking element, arrangements which can be displaced in a parallel manner are also intended to be preferably used, in particular when the spatial requirement does not permit a pivoting movement.

The lift is preferably constructed for travelling on a ground level and the at least one work scaffold and has an access portion and a first locking element which is connected to the lift.

The first locking element for actuating a locking device is constructed according to a preferred embodiment of the present invention, wherein the first locking element is connected to the lift in a first portion of the connection member by means of a first connection member, preferably a chain, a wire, wire mesh or cable, wherein the connection member is arranged with a second portion of the first connection member opposite the first portion of the first connection member in an inner space of the lift, and the first connection member extends in the locking position through the access portion of the lift.

According to another preferred embodiment, the access portion of the lift has a detection means for detecting a presence of objects in the access portion, preferably a photoelectric barrier, and further has a control system which is constructed to prevent travel of the lift when the detection means detects a presence of objects in the access portion of the lift. Two possibilities for preventing the travel of the lift in the locking position of the first locking element may be considered to be particularly preferred. On the one hand, the lift is almost prevented from travelling as a result of the mechanical connection and, on the other hand, a control system makes provision for the lift to only be in a position to travel when the door of the lift is closed. The closure of the door is either prevented mechanically as a result of the extension of the first connection member through the access portion of the lift and, on the other hand, by detecting a blockage of the access portion by the first connection member by way of the detection means.

In a preferred embodiment, the access portion of the lift has a door and the first connection member extends in the locking position of the first locking element past the door, wherein

the length of the first connection member is sized to prevent closure of the door in the locking position of the first locking element, and wherein the lift has a control system which makes provision for travel of the lift only when the door is closed.

The invention further solves the problem addressed by providing a wind turbine having a ground level, at least one work scaffold, a lift for travelling on the ground level and the at least one work scaffold, a rail which

is arranged on the work scaffold and which has a transition region to a lift, a blocking element for blocking the transition region to the lift and a second locking element which is connected to the blocking element, wherein the work scaffold is constructed according to a preferred embodiment of the present invention.

Preferably, in the wind turbine according to the invention, the lift is constructed according to a preferred embodiment of the present invention.

The present invention further relates to the use of a locking device in the manner of a deposit locking system for blocking a rail on a work scaffold of a wind turbine by means of a blocking element, wherein the blocking element is preferably arranged in a transition region to a lift.

The invention is explained in greater detail below with reference to preferred embodiments and with reference to the appended drawings, in which:

Figure 1 is a schematic illustration of a transition region of a wind turbine work scaffold according to the present invention;

Figure 2 is a schematic side view from above of the embodiment shown in Figure 1;

Figure 3 is a cross-section of a lift according to the invention and a work scaffold according to the invention from the side;

Figure 4 is a side view of the arrangement from Figure 3 from above in a first operating state;

Figure 5 shows the arrangement from Figure 4 in an alternative operating state;

Figure 6 is a schematic illustration of a wind turbine according to the invention.

Figure 1 shows a transition region between a lift and a work scaffold 1 according to the present invention, when viewed from the direction of the lift. The wind turbine work scaffold 1 has a working platform 3 and a rail 7. The rail 7 can be locked by means of a blocking element. The blocking element 5 is pivotably secured with a first hinge 17 and a second hinge 19 to a first portion 4' of the rail 7. A locking device 9 is arranged on a second portion 4 of the rail 7. The locking device 9 retains in the configuration shown a second locking element 15 in a corresponding receiving member. The second locking element 15 is secured by means of a second connection member 23 to a portion 21 opposite the second locking element on the blocking element 5. The second connection member 23 is in this instance constructed as a chain and the blocking element 5 is constructed as a door. The locking device 9 has a receiving member 11 for the second locking element and a receiving member 13 for the first locking element.

In addition to the work scaffold 1, a lift 27 is schematically illustrated from above in Figure 2. The lift 27 has an access portion 37 which is arranged between an inner space 37 of the lift 27 and the work scaffold 1 in a transition region 25 between the work scaffold 1 and the lift 27.

The lift 27 has a first locking element 29 which corresponds to the receiving member 13 illustrated in Figure 1 for the first locking element 29. The first locking element 29 has a first portion 33, to which there is secured a first connection member 31 which is constructed in this instance as a chain. The first connection member 31 is securely connected to the lift 27 at a second portion 35 in the inner space of the lift 27.

The first locking element 29 is constructed to be moved into engagement with the locking device 9 and the locking mechanism which is received therein. The locking device 9 is fixedly arranged on the rail 7 in the second portion 4 of the rail 7. The lift 27 illustrated in Figure 2 can be moved freely in the illustrated operating position and is not connected to the work scaffold 1.

An alternative operating position is illustrated in Figure 3. The lift 27 has a door 39 in the access portion 37. The door 39 is illustrated in this instance schematically as a rolling grille. A construction of the door as a sliding door is also particularly preferred. The door 39 is located in Figure 3 in the open state. The first connection member 31, which is secured in the second portion 35 inside the lift 27, extends through the access portion past the open door 39. The first portion 33 of the connection member is guided in such a manner in the vicinity of the locking device 9 that the first locking element 29 is located in a locking position with the locking mechanism inside the locking device 9. In the illustration shown, the lift 27 is securely connected to the rail 7 on the working platform 3 and travel of the lift is not possible.

Two detailed views of the alternative locking positions of the locking mechanism of the locking device 9 according to the invention are illustrated in Figures 4 and 5. The state illustrated in Figure 4 shows the second locking element 15 in the locking position inside the locking device 9, whereby the blocking element 5 is locked in the closed position relative to the rail 7. The work scaffold 1 cannot be entered or left in the position shown in Figure 4. The first locking element 29 is located in a release position, but is secured by means of the first connection member 21 to the second portion 35 inside the lift 27.

In Figure 5, however, the first locking element 29 is located in a locking position with the locking mechanism arranged inside the locking device 9. The first locking member 31, which is constructed in this instance as a chain, is substantially deployed to the maximum extent and extends through the access portion 37 from the inner space of the lift 27. The first connection member 31 is still secured to the second portion 35 inside the lift 27. In contrast to the first locking element 29, the second locking element 15 is located in a release position. The second locking element 15 is secured to a first portion 41 of a second connection member 43. The second connection member 43 which is constructed in this instance as a chain is itself secured in a second portion 47 of the connection member to the blocking element 5 which is constructed as a door. The blocking element 5 is pivoted from a closed position to an open position and angled with respect to the rail 7. In the position illustrated in Figure 5, it is possible to leave and enter the lift 27 or the work scaffold 1, whilst travel of the lift 27 is not possible.

Figure 6 is a schematic partial section of a wind turbine 49 according to the invention. The wind turbine 49 has at the inner side thereof a lift 27 according to the invention which is suspended on a pulling device 51 and which is guided by a guiding device 53. In addition to the lift 27, there are arranged inside a tower 55 of the wind turbine 49 a plurality of work scaffolds, of which two work scaffolds 1 are illustrated. The work scaffolds 1 each have a rail 7 to which a locking device 9 is fixedly fitted. Figure 6 illustrates that the lift 27 is located so close to one of the work scaffolds 1 that it is possible to pass in the transition region 25 between the lift 27 and the work scaffold 1.

Figure 6 does not illustrate that the lift can be moved upwards as far as the control booth 57 constructed with the rotor 59. However, it is established that this illustrates another alternative possibility in the context of the present invention. The control booth may also provide on a rail or a similar device a locking device according to the invention.

MUNKAÁLLVÁNY ÉS LIFT SZÉLTURBINÁHOZ

Szabadalmi igénypontok

1. Szélturbina-munkaállvány (1), melynek tartószerkezete, munkadobogója (3), valamint a munkadobogón (3) elrendezett korlátja (7) van, ahol
- 5 a korlát (7) záróelem (5) révén lezárható, és a záróelem (5) lifthez (27) irányuló átjárózónában (25) van elrendezve, **azzal jellemezve**, hogy első reteszelőelem (29) és második reteszelőelem (15) fogadásához reteszelőszerkezettel rendelkező reteszelőberendezése (9) van,
- ahol a reteszelőszerkezet letétes záróberendezés formájában van kialakítva, ahol
- az első reteszelőelem (29) a lifttel (27) van összekapcsolva, és
 - 10 – a második reteszelőelem (15) a záróelemmel (5) van összekapcsolva, és
 - a reteszelőszerkezet olyan módon van kialakítva, hogy a két reteszelőelem (15, 29) egyikét minden esetben a másik reteszelőelem (29, 15) reteszelőberendezéshez (9) viszonyított reteszelésével oldja.
2. Az 1. igénypont szerinti munkaállvány (1), **azzal jellemezve**, hogy a reteszelőszerkezet az első reteszelőelemet (29) érme, profilozott és/vagy kontúrozott lapos tag, rúd vagy üreges tag formájában fogadón van
- 15 kiképezve.
3. Az 1. vagy a 2. igénypont szerinti munkaállvány (1), **azzal jellemezve**, hogy a második reteszelőelem (15) érmeként, profilozott és/vagy kontúrozott lapos tagként, rúdként vagy üreges tagként van kiképezve.
4. Az előző igénypontok bármelyike szerinti munkaállvány (1), **azzal jellemezve**, hogy a reteszelő-
- 20 szerkezet fixen van a munkaállványon (1), előnyösen a korláton (7) elrendezve.
5. A 4. igénypont szerinti munkaállvány (1), **azzal jellemezve**, hogy
- a záróelem (5) a lifthez irányuló átjárózóna (25) első szakaszán (4') a korláttal (7) csuklósan van összekapcsolva, és
 - a reteszelőszerkezet a lifthez irányuló átjárózóna (25) első szakasszal (4') szemközti második szakaszán (4)
- 25 van elrendezve.
6. Az előző igénypontok bármelyike szerinti munkaállvány (1), **azzal jellemezve**, hogy a záróelemet (5) rúd, lánc vagy ajtó képezi.
7. Szélturbina (49), melynek van
- földszintje,
 - 30 – legalább egy munkaállványa (1),
 - a földszint és a legalább egy munkaállvány (1) közötti utazáshoz liftje (27),
 - a munkaállványon (1) elrendezett, lifthez (27) irányuló átjárózónával rendelkező korlátja (7),
 - a lifthez (27) irányuló átjárózóna (25) lezárásához záróeleme (5), valamint
 - második reteszelőeleme (15), amely a záróelemmel (5) van összekapcsolva,
 - 35 **azzal jellemezve**, hogy a munkaállvány az 1-6. igénypontok bármelyike szerint van kialakítva.

8. A 7. igénypont szerinti szélturbina (49), **azzal jellemezve**, hogy a lift (27) a földszint és a legalább egy munkaállvány közötti utazásra alkalmasan van kialakítva, továbbá belépőtartománnyal, valamint egy a lifttel összekapcsolt első reteszelőelemmel rendelkezik.

5 9. A 8. igénypont szerinti szélturbina (49), **azzal jellemezve**, hogy az első reteszelőelem (29) első részen (33) első összekötőelem (31) révén, előnyösen az összekötőelem lánc, sodronya, sodronyfonata vagy kötele révén a lifttel (27) van összekapcsolva, ahol az első összekötőelemnek (31) az első összekötőelem (31) első részével (33) szemközti második része (35) a lift (27) belső terében van elrendezve, és az első összekötőelem (31) reteszelőhelyzetben a lift (27) belépőtartományán (37) keresztül terjed.

10 10. A 9. igénypont szerinti szélturbina (49), **azzal jellemezve**, hogy tárgyak belépőtartománybeli (37) jelenlétének észlelésére a lift belépőtartománya (37) érzékelőeszközzel, előnyösen fénykapuval rendelkezik, továbbá a lift (27) vezérléssel van ellátva, amely olyan módon van kialakítva, hogy megakadályozza a lift (27) működését, amennyiben az érzékelőeszköz a lift (27) belépőtartományában tárgyak jelenlétét észleli.

15 11. A 9. vagy a 10. igénypont szerinti szélturbina (49), **azzal jellemezve**, hogy a lift (27) belépőtartománya (37) ajtóval (39) rendelkezik, az első összekötőelem (31) az első reteszelőelem (29) reteszelő helyzetében az ajtó (39) mellett terjed, és az első összekötőelem (31) hossza olyan módon van megválasztva, hogy az első reteszelőelem (29) reteszelő helyzetében az ajtó (39) bezárása gátolt, továbbá a lift (27) vezérléssel van ellátva, amely a lift (27) működését kizárólag bezárt ajtó (39) mellett teszi lehetővé.

20 12. Letétes záróberendezés alkalmazása korlát (7) lezárására szélturbina-munkaállványon (1), ahol a szélturbina-munkaállvány az 1. igénypont szerint van kialakítva.

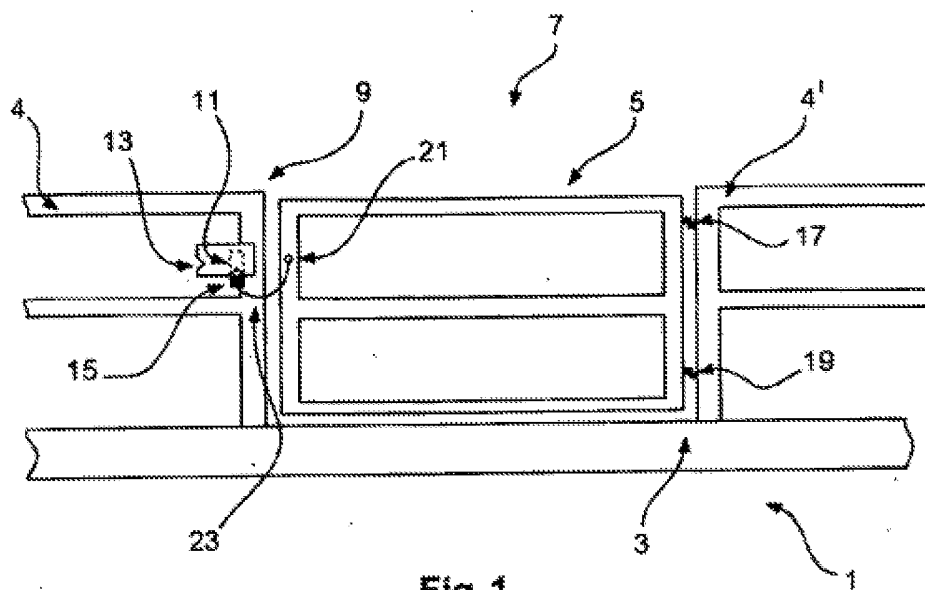

Fig. 1

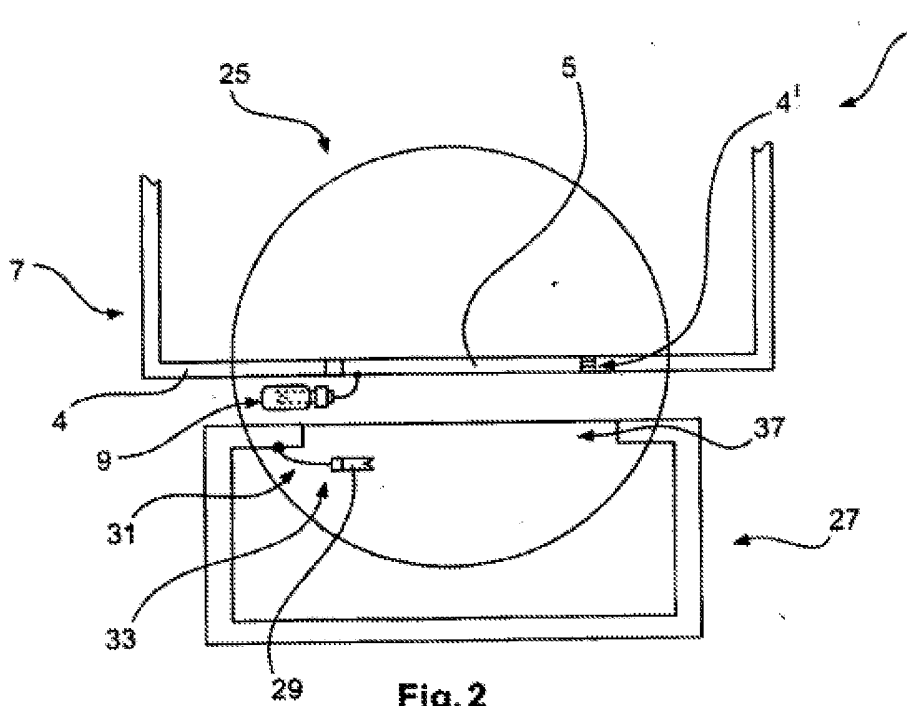

Fig. 2

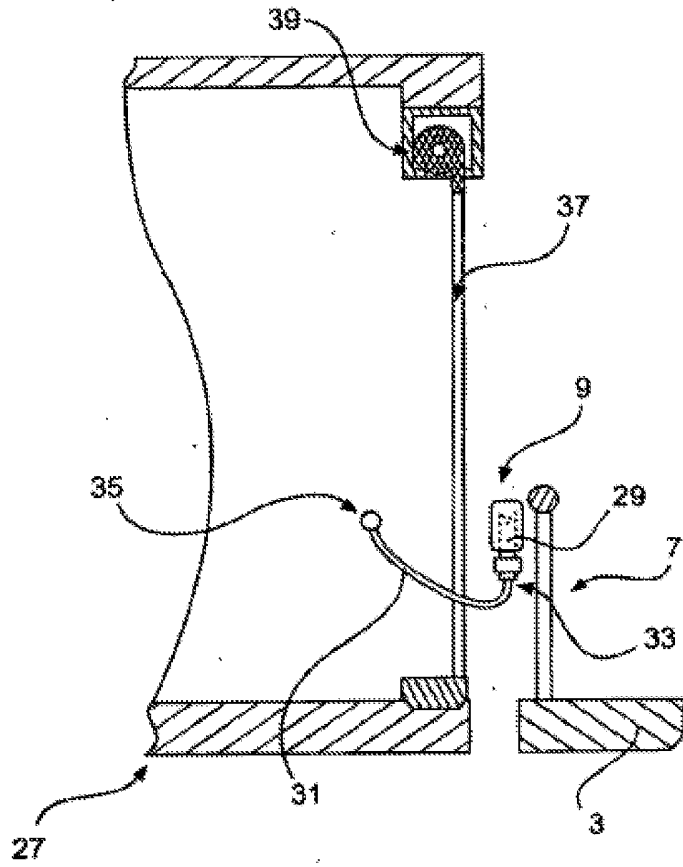

Fig. 3

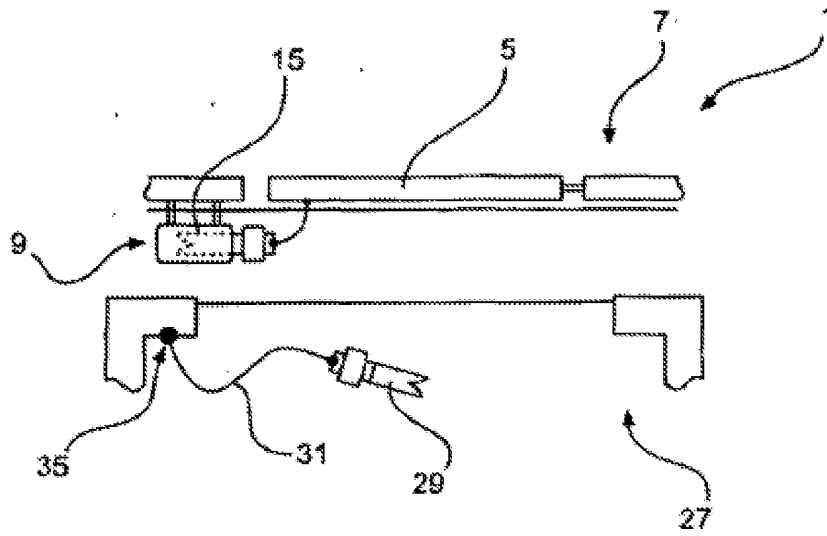

Fig. 4

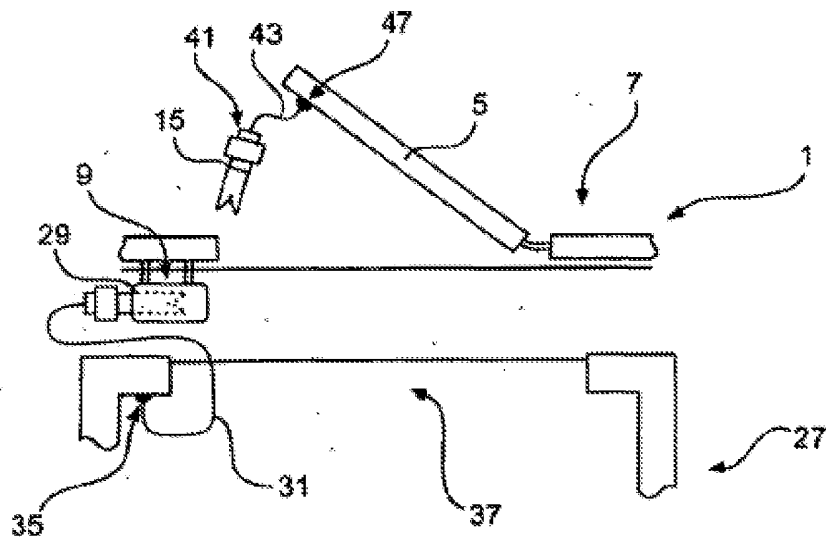

Fig. 5

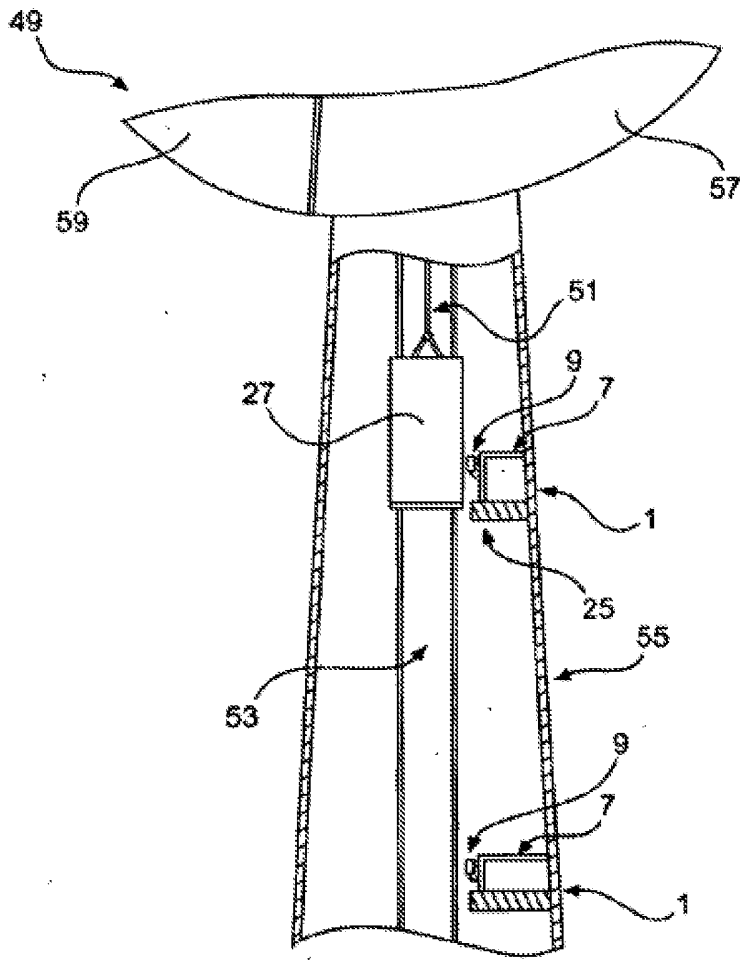

Fig. 6