

(12) INTERNATIONAL APPLICATION PUBLISHED UNDER THE PATENT COOPERATION TREATY (PCT)

(19) World Intellectual Property Organization
International Bureau



(43) International Publication Date
30 November 2000 (30.11.2000)

PCT

(10) International Publication Number
WO 00/72333 A1

- (51) International Patent Classification⁷: H01C 10/06 (74) Agents: LEUNG, Chun-Pok, Roger et al.; Townsend and Townsend and Crew LLP, Two Embarcadero Center, 8th Floor, San Francisco, CA 94111-3834 (US).
- (21) International Application Number: PCT/US00/13032
- (22) International Filing Date: 11 May 2000 (11.05.2000) (81) Designated State (*national*): JP.
- (25) Filing Language: English (84) Designated States (*regional*): European patent (AT, BE, CH, CY, DE, DK, ES, FI, FR, GB, GR, IE, IT, LU, MC, NL, PT, SE).
- (26) Publication Language: English
- (30) Priority Data: 09/318,183 25 May 1999 (25.05.1999) US — *Published:*
With international search report.
- (71) Applicant: VARATOUCH TECHNOLOGY INCORPORATED [US/US]; 7325 Roseville Road, Sacramento, CA 95842-1600 (US). *For two-letter codes and other abbreviations, refer to the "Guidance Notes on Codes and Abbreviations" appearing at the beginning of each regular issue of the PCT Gazette.*
- (72) Inventors: SCHRUM, Allan, E.; 3197 Boeing Road, Cameron Park, CA 95682 (US). ROGERS, Michael, D.; 966 King George Way, El Dorado Hills, CA 95762 (US).

(54) Title: VARIABLE RESISTANCE DEVICES AND METHODS

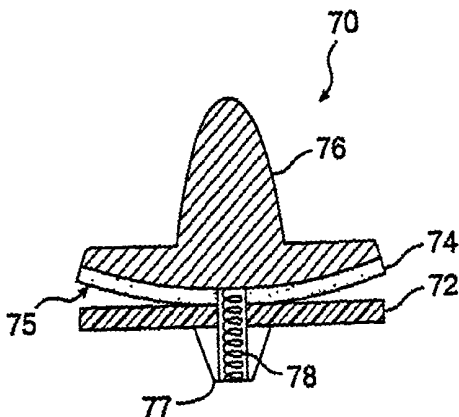

(57) Abstract: A variable resistance device comprises a resistive member having a resistive rubber material (74). A first conductor (78) and second conductor on substrate (72) are configured to be electrically coupled with the resistive member (74) at a first contact location over a first contact area, and a second contact location over a second contact area, respectively. The resistance between the first conductor at the first contact location and the second conductor at the second contact location is equal to the sum of a straight resistance component and a parallel path resistance component. The straight resistance component increases or decreases as the distance between contact locations increases or decreases respectively. Changing the contact locations and areas presets the components such that the change in resistance can be governed by the parallel or straight resistance components.

WO 00/72333 A1

VARIABLE RESISTANCE DEVICES AND METHODS

5

BACKGROUND OF THE INVENTION

This invention relates generally to variable resistance devices and methods and, more particularly, to devices and methods which employ resistive rubber materials for providing variable resistance.

Variable resistance devices have been used in many applications including sensors, switches, and transducers. A potentiometer is a simple example of a variable resistance device which has a fixed linear resistance element extending between two end terminals and a slider which is keyed to an input terminal and makes movable contact over the resistance element. The resistance or voltage (assuming constant voltage across the two end terminals) measured across the input terminal and a first one of the two end terminals is proportional to the distance between the first end terminal and the contact point on the resistance element.

Resistive elastomers or resistive rubber materials have been used as resistance elements including variable resistance devices. The terms "resistive rubber" and "resistive rubber material", as used herein, refer to an elastomeric or rubber material which is interspersed with electrically conductive materials including, for example, carbon black or metallic powder. Heretofore, the use of resistive rubber in variable resistance devices has been limited to relatively simple and specific applications. For instance, some have only exploited the variable resistance characteristics of a resistive rubber caused by deformation such as stretching and compression. There is a need for variable resistance devices and methods which utilize more fully the resistive characteristics of resistive rubber materials.

25

SUMMARY OF THE INVENTION

The present invention relates to variable resistance devices and methods that make use of the various resistive characteristics of resistive rubber materials. The inventors have discovered characteristics of resistive rubber materials that previously have not been known or utilized.

30

The resistance of a resistor is directly proportional to the resistivity of the material and the length of the resistor and inversely proportional to the cross-sectional area perpendicular to the direction of current flow. The resistance is represented by the following well-known equation:

5
$$R = \rho l / A \quad (1)$$

where ρ is the resistivity of the resistor material, l is the length of the resistor along the direction of current flow, and A is the cross-sectional area perpendicular to the current flow. Resistivity is an inherent property of a material and is typically in units of $\Omega \cdot \text{cm}$. The voltage drop across the resistor is represented by the well-known Ohm's law:

10
$$R = E / I \quad (2)$$

where E is the voltage across the resistor and I is the current through the resistor.

When resistors are joined together in a network, the effective resistance is the sum of the individual resistances if the resistors are joined in series. The effective resistance increases when the number of resistors that are joined in series increases. That is, the effective resistance increases when the total length l of the resistors increases, assuming a constant cross-sectional area A according to a specific example based on equation (1). If the resistors are joined in parallel, however, the effective resistance is the reciprocal of the sum of the reciprocals of the individual resistances. The higher the number of resistors that are joined in parallel, the lower the effective resistance is. This is also consistent with equation (1), where the effective resistance decreases when the total area A of the resistors increases in a specific example, assuming a constant length l .

Commonly available resistors typically include conductive terminals at two ends or leads that are connected between two points in a circuit to provide resistance. These resistors are simple and discrete in structure in the sense that they each have well-defined contact points at two ends with a fixed resistance therebetween. The effective resistance of a resistive network formed with resistors that have such simple, discrete structures is easily determinable by summing the resistances for resistors in series and by summing the reciprocals of the resistances for resistors that are in parallel and taking the reciprocal of the sum. Geometric factors and contact variances are absent or at least sufficiently insignificant in these simple resistors so that the effective resistance is governed by the simple equations described above. When the resistors are not simple and

discrete in structure, however, the determination of the effective resistance is no longer so straightforward.

The inventors have discovered that the effective resistance is generally the combination of a straight path resistance component and a parallel path resistance component. The straight path resistance component or straight resistance component is analogous to resistors in series in that the straight resistance component between two contact locations increases with an increase in distance between the two contact locations, just as the effective resistance increases when the total length l increases and the area A is kept constant in equation (1). The increase in the amount of resistive material in the current path between the two contact locations causes the increase in resistance. The parallel path resistance component is analogous to resistors in parallel. As discussed above, the effective resistance decreases when the total area A of the combined resistors having a common length l increases. This results because there are additional current paths or "parallel paths" provided by the additional resistors joined in parallel. Similarly, when the amount of parallel paths increases between two contact locations due to changes in geometry or contact variances, the parallel path resistance component decreases. As used herein, the term "parallel paths" denote multiple paths available for electrical current flow between contact locations, and are not limited to paths that are geometrically parallel.

In accordance with an aspect of the present invention, a variable resistance device comprises a resistive member comprising a resistive rubber material. A first conductor is configured to be electrically coupled with the resistive member at a first contact location over a first contact area. A second conductor is configured to be electrically coupled with the resistive member at a second contact location over a second contact area. The first contact location and the second contact location are spaced from one another by a distance. A resistance between the first conductor at the first contact location and the second conductor at the second contact location is equal to the sum of a straight resistance component and a parallel path resistance component. The straight resistance component increases as the distance between the first contact location and the second contact location increases, and decreases as the distance between the first contact location and the second contact location decreases. The parallel path resistance component has preset desired characteristics based on selected first and second contact locations and selected first and second contact areas.

In certain embodiments, the first and second locations and first and second contact areas are selected to provide a parallel path resistance component which is at least substantially constant with respect to changes in the distance between the first contact location and the second contact location. As a result, the resistance between the first conductor at the first contact location and the second conductor at the second contact location increases as the distance between the first contact location and the second contact location increases, and decreases as the distance between the first contact location and the second contact location decreases.

In other embodiments, the first and second contact locations and first and second contact areas are selected such that the parallel path resistance component is substantially larger than the straight resistance component. The change in the resistance between the first conductor at the first contact location and the second conductor at the second contact location is at least substantially equal to the change in the parallel path resistance component between the first conductor and the second conductor.

In still other embodiments, the resistive member has a resistive surface for contacting the first and second conductors at the first and second contact locations, respectively. The resistive surface has an outer boundary and a thickness which is substantially smaller than a square root of a surface area of the resistive surface. The parallel path resistance component between the first conductor at the first contact location and the second conductor at the second contact location is substantially larger than the straight resistance component when both the first and second contact locations are disposed away from the outer boundary of the resistive surface. The straight resistance component between the first conductor at the first contact location and the second conductor at the second contact location is substantially larger than the parallel path resistance component when at least one of the first and second contact locations is at or near the outer boundary of the resistive surface.

In accordance with other aspects of the invention, the resistance between the first conductor at the first contact location and the second conductor at the second contact location increases when the resistive member undergoes a stretching deformation between the first contact location and the second contact location. The resistance between the first conductor at the first contact location and the second conductor at the second contact location decreases when the resistive member is subject to a pressure between the first contact location and the second contact location. The resistance

between the first conductor at the first contact location and the second conductor at the second contact location increases when the resistive member undergoes a rise in temperature between the first contact location and the second contact location, and decreases when the resistive member undergoes a drop in temperature between the first contact location and the second contact location.

Another aspect of the present invention is directed to a method of providing a variable resistance from a resistive member including a resistive rubber material. The method comprises electrically coupling a first conductor with the resistive member at a first location over a first contact area and electrically coupling a second conductor with the resistive member at a second location over a second contact area. At least one of the first location, the second location, the first contact area, and the second contact area is changed to produce a change in resistance between the first conductor and the second conductor. The resistance between the first conductor and the second conductor includes a straight resistance component and a parallel path resistance component. The straight resistance component increases as the distance between the first location and the second location increases and decreases as the distance between the first location and the second location decreases. The parallel path resistance component has preset desired characteristics based on selected first and second locations and selected first and second contact areas.

BRIEF DESCRIPTION OF THE DRAWINGS

Figs. 1a-1c are elevational views of a variable resistance device exhibiting effective straight resistance characteristics in accordance with an embodiment of the present invention;

Fig. 1d is a plot of the effective resistance as a function of the contact location for the variable resistance device of Figs. 1a-1c;

Fig. 2 is a perspective view of the variable resistance device of Figs. 1-2;

Fig. 3 is a schematic view of the variable resistance device of Figs. 1a-1c;

Fig. 4 is an elevational view of a variable resistance device exhibiting effective straight resistance characteristics in accordance with another embodiment of the invention;

Fig. 5a is a plan view of a variable resistance device exhibiting effective straight resistance characteristics in accordance with another embodiment of the invention;

Fig. 5b is an elevational view of the variable resistance device of Fig. 5a;

5 Fig. 6a is a schematic view of a variable resistance device exhibiting effective parallel path resistance characteristics in accordance with an embodiment of the invention;

10 Fig. 6b is a schematic view of a variable resistance device exhibiting effective parallel path resistance characteristics in accordance with another embodiment of the invention;

Fig. 7 is a schematic view of a variable resistance device exhibiting effective parallel path resistance characteristics in accordance with another embodiment of the invention;

15 Fig. 8 is a partial cross-sectional view of a variable resistance device exhibiting effective parallel path resistance characteristics in accordance with another embodiment of the invention;

Figs. 9a-9c are schematic views illustrating parallel paths for different contact locations in the variable resistance device of Fig. 8;

20 Fig. 10 is a plot of the effective resistance as a function of distance between contact locations for the variable resistance device of Fig. 8;

Fig. 11a is a schematic view of the a conductive trace pattern of a segment of the substrate in the variable resistance device of Fig. 8 in accordance with another embodiment of the invention;

25 Fig. 11b is a schematic view of the another conductive trace pattern of a segment of the substrate in the variable resistance device of Fig. 8 in accordance with another embodiment of the invention;

Fig. 12 is an exploded perspective view of a variable resistance device exhibiting effective straight resistance characteristics in accordance with another embodiment of the invention;

30 Fig. 13 is a schematic view of a variable resistance device exhibiting effective parallel path resistance characteristics with a rectangular resistive footprint in accordance with another embodiment of the invention;

Fig. 14 is a schematic view of a variable resistance device exhibiting effective parallel path resistance characteristics with a triangular resistive footprint in accordance with another embodiment of the invention;

Fig. 15 is a schematic view of a variable resistance device exhibiting effective parallel path resistance characteristics with a logarithmic resistive footprint in accordance with another embodiment of the invention;

Fig. 16 is a plot of the effective resistance as a function of displacement of the resistive footprint for the variable resistance device of Fig. 15;

Fig. 17 is an exploded perspective view of a variable resistance device exhibiting effective straight resistance characteristics with a logarithmic conductor footprint in accordance with another embodiment of the invention; and

Fig. 18 is a plot of the effective resistance as a function of contact location between the resistive rubber transducer and the conductor footprint for the variable resistance device of Fig. 17.

DESCRIPTION OF THE SPECIFIC EMBODIMENTS

The variable resistance devices of the present invention include components made of resistive rubber materials. An example is a low durometer rubber having a carbon or a carbon-like material imbedded therein. The resistive rubber advantageously has a substantially uniform or homogeneous resistivity, which is typically formed using very fine resistive particles that are mixed in the rubber for a long period of time in the forming process. The resistive property of resistive rubber material is typically measured in terms of resistance per a square block or sheet of the material. The resistance of a square block or sheet of a resistive rubber material measured across opposite edges of the square is constant without regard to the size of the square. This property arises from the counteracting nature of the resistance-in-series component and resistance-in-parallel component which make up the effective resistance of the square of material. For instance, when two square blocks of resistive rubber material each having a resistance of 1Ω across opposite edges are joined in series, the effective resistance becomes 2Ω due to the doubling of the length. By coupling two additional square blocks along the side of the first two square blocks to form a large square, the effective resistance is the reciprocal of the sum of the reciprocals. The sum of the reciprocals is $\frac{1}{2} \Omega^{-1} + \frac{1}{2} \Omega^{-1} = 1 \Omega^{-1}$. Thus the effective resistance for a large square that is made up of 4

small squares is 1Ω , which is the same as the resistance of each small square. The use of the resistance-in-series or straight path resistance component and the resistance-in-parallel or parallel path resistance component of the resistive rubber material is discussed in more detail below.

5 The resistance per square of the resistive rubber material employed typically falls within the range of about 10-100 Ω per square. In some applications, the variable resistance device has a moderate resistance below about 50,000 ohms (Ω). In certain applications involving joysticks or other pointing devices, the range of resistance is typically between about 1,000 and 25,000 ohms. Advantageously, the resistive rubber
10 material can be formed into any desirable shape, and a wide range of resistivity for the material can be obtained by varying the amount of resistive particles embedded in the rubber material.

 The resistive response of a variable resistance device made of a resistive rubber material can be attributed to three categories of characteristics: material
15 characteristics, electrical characteristics, and mechanical characteristics.

A. Material Characteristics

 The resistance of a resistive rubber material increases when it is subjected to stretching and decreases when it is subjected to compression or pressure. The deformability of the resistive rubber material renders it more versatile than materials that
20 are not as deformable as the resistive rubber material. The resistance of a resistive rubber material increases with an increases in temperature and decreases with a decrease in temperature.

B. Electrical Characteristics

 The effective resistance of a resistive rubber component is generally the
25 combination of a straight path resistance component and a parallel path resistance component. The straight path resistance component or straight resistance component is analogous to resistors in series in that the straight resistance component between two contact locations increases with an increase in distance between the two contact locations, just as the effective resistance increases when the number of discrete resistors joined in
30 series increases. The parallel path resistance component is analogous to resistors in parallel in that the parallel path resistance component decreases when the amount of parallel paths increases between two contact locations due to changes in geometry or contact variances, just as the effective resistance decreases when the number of discrete

resistors joined in parallel increases, representing an increase in the amount of parallel paths.

To demonstrate the straight resistance characteristics and parallel path resistance characteristics, specific examples of variable resistance devices are described herein. In some examples, straight resistance is the primary mode of operation. In other
5 examples, parallel path resistance characteristics are dominant.

1. Straight Path Resistance

One way to provide a variable resistance device that operates primarily in the straight resistance mode is to maintain the parallel path resistance component at a
10 level which is at least substantially constant with respect to changes in the distance between the contact locations. The parallel path resistance component varies with changes in geometry and contact variances. The parallel path resistance component may be kept substantially constant if, for example, the geometry of the variable resistance
15 device, the contact locations, and the contact areas are selected such that the amount of parallel paths between the contact locations remains substantially unchanged when the contact locations are moved.

An example is a potentiometer 10 shown in Figs. 1a-1c. A resistive rubber transducer 12 is disposed adjacent and generally parallel to a conductor or conductive
20 substrate 14. The resistive rubber transducer 12 is supported at two ends by end supports 16a, 16b, and is normally spaced from the conductor 14 by a small distance. A roller or wheel mechanism 18 is provided for applying a force on the transducer 12 to deflect the transducer 12 to make contact with the conductor 14 at different locations between the
25 two ends of the transducer 12, as illustrated in Figs. 1a-1c. In this embodiment, one end of the resistive rubber transducer 12 adjacent the first end support 16a is grounded and the other end adjacent the second end support 16b is energized with an applied voltage V . As the roller mechanism 18 deflects the transducer 12 to contact the conductor 14 at different
30 locations, voltage measurements taken along the length of the transducer 12 increases as the contact location approaches the end with the applied voltage V . Also, resistance readings R taken at the contact locations d vary between the two ends of the transducer 12. This is illustrated in the plot in Fig. 1d.

Fig. 2 shows that the transducer 12 and conductor 14 have generally constant widths and the roller mechanism 18 is set up so that the contact area between the transducer 12 and the conductor 14 remains generally constant at different contact

locations. The contact area preferably extends across the entire width of the transducer 12 which amounts to a substantial portion (almost half) of the perimeter of the cross-section of the transducer 12 at the contact location. The resistive rubber transducer 12 has a substantially uniform cross-section, and the resistive rubber preferably has substantially uniform resistive properties. The voltage V is applied at the end of the transducer 12 substantially across the entire cross-section. This may be done by capping the entire end with a conductive cap or conductive end support 16b and applying the voltage through the conductive end support 16b. The other end of the transducer 12 is grounded preferably also across the entire cross-section, for instance, by capping the end with a grounded conductive end support 16a. This end may alternatively be energized with another voltage which is different from the voltage V to create the voltage differential between the two ends of the transducer. In a specific embodiment, the resistive rubber transducer 12 has a thickness which is significantly smaller than its width and length (e.g., the width is at least about 5 times the thickness), so that the transducer 12 is a thin strip, which is flat and straight in the embodiment shown.

Current flows from the applied voltage end of the transducer 12 to the grounded end of the transducer 12 via parallel paths that extend along the length of the transducer 12. For the variable resistance device 10, the contact area between the resistive rubber transducer 12 and the conductor 14 is substantially constant and the amount of parallel paths remains substantially unchanged as the contact location is moved across the length of the transducer. As a result, the parallel path resistance component is kept substantially constant, so that the change in the effective resistance of the device 10 due to a change in contact location is substantially equal to the change in the straight resistance component. The straight resistance component typically varies in a substantially linear fashion with respect to the displacement of the contact location because of the uniform geometry and homogeneous resistive properties of the resistive rubber material (see Fig. 1d). Fig. 3 shows a schematic representation of the potentiometer 10 of Figs. 1-2.

Another variable resistance device 20 which also operates primarily on straight resistance principles is shown in Fig. 4. The device 20 includes a generally longitudinal resistive rubber member 22 which is substantially uniform in cross-section. For instance, the member 22 may be generally identical to the resistive rubber transducer 12 in Fig. 2. One end of the resistive rubber member 22 is coupled to a first conductor

24, preferably across substantially the entire cross-section. A second conductor 26 makes movable contact with the resistive rubber member 22 along its length to define a variable distance with respect to the first conductor 24. In this embodiment, the movable conductor 26 includes a roller with a curved surface which makes rolling contact on the surface of the resistive rubber member 22. The contact area between the movable conductor 26 and the resistive rubber member is substantially constant, and preferably extends across the entire width of the member 22 which amounts to a substantial portion (almost half) of the perimeter of the cross-section of the member 22 at the contact location. In this way, the amount of parallel paths between the first conductor 24 and the second conductor 26 is substantially unchanged during movement of the second conductor 26 relative to the first conductor 24. The effective resistance of the variable resistance device 20 exhibits straight resistance characteristics, and increases or decreases when the variable distance between the first conductor 24 and the second conductor 26 increases or decreases, respectively. If the resistive properties of the resistive rubber material are substantially uniform, the effective resistance varies substantially linearly with respect to changes in the distance between the first conductor 24 and the second conductor 26 in a manner similar to that shown in Fig. 1d.

Another example of a variable resistance device 30 as shown in Figs. 5a and 5b employs two conductors 32, 34 in tandem. The conductor surfaces of the two conductors 32, 34 which are provided for making contact with a resistive surface or footprint 36 are spaced from each other by a variable distance. In the embodiment shown, the conductors 32, 34 are longitudinal members with substantially constant widths, and the distance between them increases from one end of each conductor 32, 34 to the other end. The resistive footprint 36 movably contacts the first conductor surface of the first conductor 32 over a first contact area and the second conductor surface of the second conductor 34 over a second contact area. Fig. 5a shows movement of the footprint 36 to positions 36a, 36b. The first contact area and second contact area respectively remain substantially constant during movement of the footprint 36 to positions 36a, 36b. In the embodiment shown, the resistive footprint 36 is substantially constant in area and circular in shape. Fig. 5b shows an embodiment of a resistive rubber member 38 which provides the circular resistive footprint 36. The resistive rubber member 38 includes a curved resistive surface which is manipulated by a stick or joystick 40 to make rolling contact with the conductors 32, 34. In the embodiment shown, the

conductor 32, 34 are disposed on a substrate 42, and the resistive rubber member 38 is resiliently supported on the substrate 42. When a force is applied on the joystick 40 to push the resistive rubber member 38 down toward the substrate 42, it forms a resistive footprint 36 in contact with the conductors 32, 34. When the force shifts in the direction of the conductors 32, 34, the footprint 36 moves to locations 36a, 36b. When the force is removed, the resilient resistive rubber member 38 is configured to return to the rest position shown in Fig. 5b above the conductors 32, 34. The resistive rubber member 38 preferably has a thickness which is substantially less than a square root of the area of the resistive footprint. For example, the thickness may be less than about 1/5 of the square root of the area of the resistive footprint.

The resistive footprint 36 bridges across the two conductor surfaces defined by an average distance over the footprint 36. The use of an average distance is necessary because the distance is typically variable within a footprint. Given the geometry of the variable resistance device 30 and the contact locations and generally constant contact areas between the conductors 32, 34 and the footprint 36 of the resistive rubber member 38, the amount of parallel paths between the two conductors 32, 34 is substantially unchanged. As a result, the change in the effective resistance is substantially governed by the change in the straight resistance component of the device 30, which increases or decreases with an increase or decrease, respectively, of the average distance between the portions of the conductor surfaces of the two conductors 32, 34 which are in contact with the resistive footprint 36. If the average distance varies substantially linearly with displacement of the resistive footprint 36 relative to the conductors 32, 34 (e.g., from d_1 to d_2 as shown for a portion of the conductors 32, 34 in Fig. 5a), and the resistive properties of the resistive rubber material are substantially constant, then the effective resistance also varies substantially linearly with displacement of the footprint 36. Alternatively, a particular nonlinear resistance curve can result by arranging the conductors 32, 34 to define a specific variation in the average distance between them (e.g., logarithmic variations).

2. Parallel Path Resistance

The effective resistance of a device exhibits parallel path resistance behavior if the straight resistance component is kept substantially constant. Figs. 6 and 7 show examples of variable resistance devices that operate primarily in the parallel path resistance mode.

In Fig. 6a, the variable resistance device 50 includes a pair of conductors 52, 54 which are spaced from each other by a gap 55 which is substantially constant in size. The conductor surfaces of the conductors 52, 54 in the embodiment shown are generally planar and rectangular with straight edges defining the gap 55. The edges which define the gap may have nonlinear shapes in other embodiments. A resistive footprint 56 bridges across the gap between the conductors 52, 54 and changes in size to footprints 56a, 56b. In the embodiment shown, the resistive footprint 56 is circular and makes movable contact with the conductors 52, 54 in a generally symmetrical manner as it increases in size to footprints 56a, 56b. Alternate footprint shapes and nonsymmetrical contacts may be employed in other embodiments. The movable contact may be produced by a resistive rubber member similar to the resistance member 38 shown in Fig. 5 with the joystick 40 for manipulating the movement of the footprint 56. The change in the area of the footprint 56 may be generated by increasing the deformation of the resistive rubber member 38. For instance, a larger force pushing downward on the joystick 40 against the resistive rubber member 38 produces greater deformation of the resistive rubber member 38 and thus a larger footprint size.

Because the gap 55 between the conductors 52, 54 which is bridged by the resistive footprint 56 is substantially constant, the straight resistance component of the overall resistance is substantially constant. The effective resistance of the variable resistance device 50 is thus dictated by the parallel path resistance component. The amount of parallel paths increases with an increase in the contact areas between the resistive footprint from 56 to 56a, 56b and the conductors 52, 54. The parallel path resistance component decreases with an increase in parallel paths produced by the increase in the contact areas. Thus, the effective resistance of the device 50 decreases with an increase in the contact area from the footprint 56 to footprints 56a, 56b. In the embodiment shown, the contact areas between the resistive footprint 56 and the conductors 52, 54 increase continuously in the direction of movable contact from the footprint 56 to footprints 56a, 56b. In such a configuration, the parallel path resistance component between the conductors 52, 54 decreases in the direction of the movable contact. The change in the contact areas can be selected to provide a particular resistance response for the variable resistance device 50 such as, for example, a resistance that decreases in a linear manner with respect to the displacement of the footprint 56 in the direction to footprints 56a, 56b.

Although Fig. 6a shows a moving resistive footprint 56, a similar variable resistance device 50' will exhibit similar characteristics for a stationary footprint 56 that changes in size to footprints 56a, 56b as illustrated in Fig. 6b. Further, Fig. 6a shows a footprint 56 that maintains its circular shape, but a footprint 56 in an alternative
5 embodiment may change shape (e.g., from circular to elliptical) in addition to size.

In Fig. 7, the variable resistance device 60 includes a pair of conductors 62, 64 having nonuniformly shaped conductor surfaces for making contact with a resistive footprint 66. The conductor surfaces are spaced by a substantially constant gap 65 in a manner similar to that shown in Fig. 6a. The resistive footprint 66 is circular and
10 makes movable contact with the conductor surfaces which are triangular in this embodiment. The resistive footprint 66 maintains a substantially constant size when it moves over the conductor surfaces to footprint 66a. This device 60 is similar to the device 50 in Fig. 6a except for the triangular conductor surfaces and the substantially constant footprint size. As in the device 50 in Fig. 6a, the constant gap 65 in this device
15 60 produces a straight resistance component that is substantially constant. When the resistive footprint 66 moves relative to the conductors 62, 64 to footprint 66a, the contact areas between the footprint 66 and the conductors 62, 64 increase due to the shape of the triangular conductor surfaces, thereby increasing the amount of parallel paths and lowering the parallel path resistance component. The contact areas change in size in the
20 device 50 of Fig. 6a due to variations in the footprint size, while the contact areas change in size in the device 60 of Fig. 7 due to variations in the shape of the conductor surfaces. As compared to the device 50 of Fig. 6a, the variable resistance device 60 depicted in Fig. 7 represents a different way of selecting the geometry, contact locations, and contact areas to produce an alternate embodiment that operates similarly in the parallel path
25 resistance mode.

Another way to ensure that a variable resistance device operates primarily in the parallel path resistance mode is to manipulate the geometric factors and contact variances such that the parallel path resistance component is substantially larger than the straight resistance component. In this way, the change in the effective resistance is at
30 least substantially equal to the change in the parallel path resistance component.

An example of a variable resistance device in which the parallel path resistance component is dominant is a joystick device 70 shown in Fig. 8. The variable resistance joystick device 70 includes a conductive substrate 72, a resistive rubber

transducer 74 having a curved resistive surface 75 in rolling contact with the surface of the conductive substrate 72, and a stick 76 coupled with the transducer 74 for moving the transducer 74 relative to the conductive substrate 72. A conductive spring 78 extends through an opening in the central region of the conductive substrate 72 and resiliently couples a center contact portion 79 of the transducer 74 to a fixed pivot region 77 relative to the conductive substrate 72. The spring 78 is electrically insulated from the conductive substrate 72. In the embodiment shown, a voltage is applied through the conductive spring 78 to the center portion of the resistive rubber transducer 74. In a specific embodiment, the resistive rubber transducer 74 has a small thickness which is substantially smaller than the square root of the surface area of the resistive surface 75.

In operation, the user applies a force on the stick 76 to roll the transducer 74 with respect to the conductive substrate 72 while the spring 78 pivots about the pivot region 77. The resistive surface 75 makes movable contact with the surface of the conductive substrate 72. Figs. 9a-9c show several movable contact locations or footprints 80a, 80b, 80c on the resistive surface 75 of the transducer 74 at different distances from the contact portion 79 where the voltage is applied. Current flows from the conductive spring 78 to the center contact portion 79 of the transducer 74 through the resistive rubber material of the transducer 74 to the conductive substrate 72 at the contact location (80a, 80b, 80c) where the voltage is read. There will be a drop in voltage from the voltage source at the contact portion 79 to the contact location with the conductive substrate 72 as the current travels through the resistive rubber material of the transducer 74.

Figs. 9a-9c schematically illustrate parallel paths 82a-82c on the resistive surface 75 between the contact portion 79 and the movable contact locations 80a-80c. Figs. 9a-9c do not show the parallel paths through the body of the resistive rubber transducer 74 but only the parallel paths 82a-82c over the resistive surface 75, which are representative of the amount of parallel paths through the body of the transducer 74 between the contact portion 79 and the movable contact locations 80a-80c. The contact area sizes of the contact locations 80a-80c preferably are substantially constant. The shape of the contact area typically is also generally constant.

In Fig. 9a, both the contact portion 79 for the applied voltage and the contact location 80a are disposed generally in a central region of the resistive surface 75 and away from the outer edge of the resistive surface 75. In this configuration, both the contact portion 79 and the contact location 80a are surrounded by resistive rubber

material. The current flows from the contact portion 79 in an array of parallel paths 82a in many directions into the resistive rubber material of the transducer 74 surrounding the contact portion 79 toward the contact location 80a also from different directions surrounding the contact location 80a. In contrast, the straight resistance component
5 between the contact portion 79 and the contact location 80a as defined by the distance between them is significantly smaller than the dominant parallel path resistance component. Due to the short distance between the contact portion 79 and the contact location 82a which limits the amount of resistive rubber material through which the current travels, the amount of parallel paths 82a is relatively small.

10 In Fig. 9b, the contact location 80b moves further away from the contact portion 79, but still stays generally in a central region of the resistive surface 75 away from the outer edge of the resistive surface 75. Because the contact location 80b is spaced further from the contact portion 79, there is a larger amount of resistive rubber material and thus a larger amount of parallel paths 82b for the current to flow than in Fig.
15 9a. The increase in parallel paths causes a decrease in the parallel path resistance component. The greater distance between the contact portion 79 and the contact location 80b produces an increase in the straight resistance component, but it is still a small component compared to the parallel path component due to the presence of the large amount of parallel paths which more than compensates for the increase in straight
20 resistance. Therefore, the effective resistance decreases as the contact location 80b moves further away from the fixed center contact portion 79.

Eventually the additional generation of parallel paths decreases as the distance increases between the contact portion 79 and the contact location increases. In the embodiment shown in Fig. 9c, this occurs when the contact location 80c approaches
25 the edge of the resistive surface 75, where the contact location 80c is no longer surrounded by as much resistive rubber material as in Figs. 9a and 9b. The resistive rubber material available for the parallel paths 82c is limited by geometric factors. Meanwhile, the straight resistance component continues to increase as a result of the increase in distance.

30 Fig. 10 shows a plot of the effective resistance R as a function of the footprint distance D from the center contact portion 79. The effective resistance R initially exhibits parallel path resistance characteristics, and decreases as the contact moves from the contact location 80a in Fig. 9a to contact location 80b in Fig. 9b. A

portion of the resistance curve in Fig. 10 is substantially linear. This occurs where the distance between the center contact portion 79 and the contact location 80b is in the medium distance range between about 2.5 and 6.5 normalized with respect to the radius of the resistive surface 75. When the contact location 80c approaches the edge of the resistive surface 75 as shown in Fig. 9c, a cross-over occurs where the straight resistance component overtakes the parallel path resistance component and becomes the dominant component. This cross-over is seen in Fig. 10 as a rise in the effective resistance with an increase in footprint distance to about 7.5-8.5 near the edge of the resistive surface 75. The cross-over phenomenon can be used in certain applications as a switch activated by the movement of the contact location 82c toward the edge of the resistive surface 75.

In Fig. 8, the surface of the conductive substrate 72 over which the resistive rubber transducer 74 rolls and makes movable contact is assumed to be divided into two or more segments (typically four) to provide directional movement in two axes. Figs. 11a and 11b show segments of alternative conductive patterns that can be used to modify the resistance characteristics of the variable resistance device 70. Fig. 11a shows a continuous conductive pattern 86 on the substrate, while the Fig. 11b shows a conductive pattern 88 made up of individual conductive traces. In both cases, the amount of conductive material for contacting with the footprint of the resistive surface 75 increases as the contact location moves further away from the center contact portion 79. Thus, the effective contact area between the resistive footprint and the conductive pattern 86, 88 increases in size as the footprint distance from the center contact portion 79 increases (even though the size of the footprint remains generally constant), so that the increase in the amount of parallel paths is amplified with respect to increase in the footprint distance. As a result, the effective resistance exhibits more pronounced parallel path characteristics until the resistive footprint approaches the edge of the resistive surface 75. The embodiments in Figs. 11a and 11b introduce the additional factor of varying the effective contact area to manipulate the effective resistance characteristics of the variable resistance device 70.

As discussed above, the straight path resistance component becomes dominant as the contact location 82c of the resistive footprint approaches the edge of the resistive surface 75 as shown in Figs. 9c and 10. Another embodiment of a variable resistance device 90 which makes use of this property is shown in the exploded view of Fig. 12. The device 90 includes a thin sheet of resistive rubber member 92 which is

rectangular in the embodiment shown. One corner 94 is energized with an applied voltage V , while another corner 96 is grounded. Alternatively, the second corner 96 can be energized with a different voltage to create a voltage differential across the resistive rubber member 92. A conductive sheet 98 is disposed generally parallel with and spaced above the resistive rubber sheet 92. A force can be applied via a pen 99 or the like to bring the resistive rubber sheet 92 and the conductive sheet 98 in contact at various contact locations. In this variable resistance device 90, the straight resistance component is dominant, partly because the formation of parallel paths is limited by the lack of resistive material surrounding the corners 94, 96. The amount of parallel paths remains limited even when the contact with the conductive sheet 98 is made in the center region of the resistive rubber sheet 92 because the voltage is applied at the corner 94. In contrast, the application of the voltage in the center contact portion 79 in the device 70 shown in Fig. 8 allows current to flow in many directions into the resistive rubber material that surrounds the center contact portion 79.

The above examples illustrate some of the ways of controlling the geometry and contact variances to manipulate the straight resistance and parallel path resistance components to produce an effective resistance having certain desired characteristics.

C. Mechanical Characteristics

Another factor to consider when designing a variable resistance device is the selection of mechanical characteristics for the resistive rubber member and the conductors. This includes, for example, the shapes of the components and their structural disposition that dictates how they interact with each other and make electrical contacts.

The use of a resistive rubber strip 12 to form a potentiometer is illustrated in Figs. 1-2. The use of conductive bars 32, 34 are shown in Figs. 5a and 5b. A flat sheet of resistive rubber is illustrated in Fig. 12. In the configuration of Fig. 12, typically two corners are energized with voltage potentials and the remaining two corners are grounded. A voltage is read through the contact between the conductive sheet 98 and the resistive rubber sheet 92 and processed to determine the contact location over an X-Y Cartesian coordinate system using methods known in the art. The variable resistance device 90 of this type is applicable, for example, as a mouse pointer or other control interface tools.

Resistive rubber members in the form of curved sheets are shown in Figs. 5b and 8. The examples of Figs. 5b and 8 represent joysticks or joystick-like structures,

but the configuration may be used in other applications such as pressure sensors. For instance, the force applied to a curved resistive rubber sheet may be caused by a variable pressure and the contact area between the curved resistive rubber sheet and a conductive substrate may be proportional to the level of the applied pressure. In this way, the change
5 in resistance can be related to the change in pressure so that resistance measurements can be used to compute the applied pressure.

Another mechanical shape is a rod. In Fig. 4, the example of a conductive rod 26 is shown. A rod produces a generally rectangular footprint. The rod configuration can also be used for a resistive rubber member to produce a rectangular resistive
10 footprint. An example is the variable resistance device 100 shown in Fig. 13, which is similar to the device 60 of Fig. 7. The device 100 has a similar pair of conductors 102, 104 spaced by a similar gap 105. The difference is that the resistive footprints 106, 106a are rectangular as opposed to the circular footprints 66, 66a in Fig. 7. The change in the shape of the footprint 106 will produce a different resistance response, but the effective
15 resistance is still governed by the parallel path resistance component as in the device 60 of Fig. 7.

Yet another mechanical shape for a footprint is that of a triangle, which can be produced by a cone or a wedge. In Fig. 14, the variable resistance device 110 is similar to the device 50 in Fig. 6, and includes a pair of conductors 112, 114 spaced by a
20 gap 115. Instead of a circular resistive footprint 56 that changes in size, the device 110 uses a triangular resistive footprint 116 that makes movable contact with the conductors 112, 114 in the direction of the gap 115. As a result, the contact areas between the resistive footprint 116 and the conductors 112, 114 increase in the direction of movement of the footprint 116 even though the footprint 116 is constant in size, creating a similar
25 effect as that illustrated in Fig. 6. In this embodiment, due to the substantial linear increase in contact areas, the resistance response is also substantially linear.

In the variable resistance device 120 of Fig. 15, the shape of the triangular resistive footprint 126 is modified to produce a logarithmic resistance response when it makes movable contact with the conductors 122, 124 in the direction of the gap 125. The
30 change in resistance R is proportional to the logarithm of the displacement D of the resistive footprint 126 in the direction of the gap 125. A plot of the change in resistance R versus the displacement D of the resistive footprint 126 is shown in Fig. 16.

A logarithmic resistance response can also be produced using the embodiment of Figs. 1-2 if the rectangular conductive member 14 is replaced by a generally triangular conductive member 14', as illustrated in the variable resistance device 130 of Fig. 17. The conductor 16a is grounded while the conductor 16b is energized with a voltage V . Fig. 18 shows a plot of the resistance R versus the distance of the contact location between the resistive rubber transducer 12 and the conductive member 14' measured from the end of the transducer 12 adjacent the conductor 16b where the voltage V is applied.

As illustrated by the above examples, resistive rubber materials can be shaped and deformed in ways that facilitate the design of variable resistance devices having a variety of different geometries and applications. Furthermore, devices made of resistive rubber materials are often more reliable. For instance, the potentiometer shown in Figs. 1-2 provides a resistive rubber transducer 12 having a relatively large contact area as compared to those in conventional devices. The problem of wear is lessened. The large contact area also renders the potentiometer less sensitive than conventional devices to contamination such as the presence of dust particles.

It will be understood that the above-described arrangements of apparatus and methods therefrom are merely illustrative of applications of the principles of this invention and many other embodiments and modifications may be made without departing from the spirit and scope of the invention as defined in the claims. For instance, alternate shapes and structural connections can be utilized to produce variable resistance devices having a variety of different resistance characteristics. Geometric factors and contact variances can be manipulated in other ways to produce specific resistance responses.

WHAT IS CLAIMED IS:

1 1. A variable resistance device comprising:
2 a resistive member comprising a resistive rubber material;
3 a first conductor which is configured to be electrically coupled with the
4 resistive member at a first contact location over a first contact area; and
5 a second conductor which is configured to be electrically coupled with the
6 resistive member at a second contact location over a second contact area, the first contact
7 location and the second contact location being spaced from one another by a distance,
8 wherein a resistance between the first conductor at the first contact
9 location and the second conductor at the second contact location is equal to the sum of a
10 straight resistance component and a parallel path resistance component, the straight
11 resistance component increasing as the distance between the first contact location and the
12 second contact location increases and decreasing as the distance between the first contact
13 location and the second contact location decreases, the parallel path resistance component
14 having preset desired characteristics based on selected first and second contact locations
15 and selected first and second contact areas.

1 2. The variable resistance device of claim 1 wherein the first and
2 second contact locations and first and second contact areas are selected to provide a
3 parallel path resistance component which is at least substantially constant with respect to
4 changes in the distance between the first contact location and the second contact location,
5 so that the resistance between the first conductor at the first contact location and the
6 second conductor at the second contact location increases as the distance between the first
7 contact location and the second contact location increases and decreases as the distance
8 between the first contact location and the second contact location decreases.

1 3. The variable resistance device of claim 2 wherein the resistive
2 member has a length between two ends and a cross-section, the cross-section being at
3 least substantially uniform along the length; wherein the first contact location is at one of
4 the two ends, and the second contact location is movable over a resistive surface along the
5 length between the two ends of the resistive member; and wherein the first contact area
6 comprises at least substantially the entire cross-section of the resistive member at the first
7 contact location, and the second contact area is at least substantially constant and

8 comprises an area of the resistive surface of the resistive member which extends over a
9 substantial portion of a perimeter of the cross-section of the resistive member at the
10 second contact location.

1 4. The variable resistance device of claim 3 wherein the resistive
2 member has a width and a thickness which is substantially smaller than the width; and
3 wherein the second contact area extends at least substantially across the width on one side
4 of the resistive member at the second contact location.

1 5. The variable resistance device of claim 4 wherein the width of the
2 resistive member is at least about 5 times the thickness.

1 6. The variable resistance device of claim 3 wherein the resistive
2 surface is substantially planar.

1 7. The variable resistance device of claim 3 wherein at least a portion
2 of the resistive member is substantially linear along the length.

1 8. The variable resistance device of claim 3 wherein the second
2 conductor is disposed along at least a portion of the length of the resistive member and is
3 spaced from the resistive member, at least one of the second conductor and the resistive
4 member being deflectable to make contact with the other one of the second conductor and
5 the resistive member at different second contact locations on the resistive member.

1 9. The variable resistance device of claim 3 wherein the second
2 conductor has a curved surface which is rollable on the resistive surface along the length
3 of the resistive member.

1 10. The variable resistance device of claim 3 wherein the increase and
2 decrease in resistance is substantially linear with respect to the increase and decrease,
3 respectively, in the distance between the first contact location and the second contact
4 location over at least a portion of the length of the resistive member.

1 11. The variable resistance device of claim 3 wherein the first
2 conductor at the first contact location at one end of the resistive member is energized with
3 a voltage and the other end of the resistive member is grounded or energized with another
4 voltage different from the voltage at the first contact location.

1 12. The variable resistance device of claim 2 wherein the first
2 conductor comprises a first conductor surface and the second conductor comprises a
3 second conductor surface which is at least substantially fixed relative to the first
4 conductor surface and spaced from the first conductor surface by a variable distance; and
5 wherein the resistive member has a resistive footprint for movably contacting the first
6 conductor surface over a first contact area and the second conductor surface over a second
7 contact area, the first contact area being at least substantially constant and the second
8 contact area being at least substantially constant, the resistive footprint bridging across
9 the first conductor surface at the first contact location and the second conductor surface at
10 the second contact location with an average distance, such that the resistance between the
11 first conductor at the first contact location and the second conductor at the second contact
12 location increases as the average distance between the first contact location and the
13 second contact location increases, and decreases as the average distance between the first
14 contact location and the second contact location decreases.

1 13. The variable resistance device of claim 12 wherein the first
2 conductor surface comprises a first longitudinal conductor surface and the second
3 conductor surface comprises a second longitudinal conductor surface.

1 14. The variable resistance device of claim 13 wherein the first
2 longitudinal conductor surface comprises a first strip which is at least substantially linear
3 and has a first width which is at least substantially constant, and the second longitudinal
4 conductor surface comprises a second strip which is at least substantially linear and has a
5 second width which is at least substantially constant, the second strip being nonparallel to
6 the first strip.

1 15. The variable resistance device of claim 12 wherein the resistive
2 member has a thickness which is substantially less than a square root of the area of the
3 resistive footprint.

1 16. The variable resistance device of claim 12 wherein the resistive
2 footprint is at least substantially circular or rectangular or triangular.

1 17. The variable resistance device of claim 12 wherein the resistive
2 footprint is at least substantially constant in area.

1 18. The variable resistance device of claim 1 wherein the first and
2 second contact locations and first and second contact areas are selected such that the
3 straight resistance component is substantially larger than the parallel path resistance
4 component and the change in the resistance between the first conductor at the first contact
5 location and the second conductor at the second contact location is at least substantially
6 equal to the change in the straight resistance component between the first conductor and
7 the second conductor.

1 19. The variable resistance device of claim 18 wherein the resistive
2 member comprises a resistive sheet having a corner being coupled with the first
3 conductor which is energized with a voltage and wherein the second conductor is
4 configured to make movable contact with the resistive sheet at the second contact
5 location, such that the change in the resistance between the first conductor at the corner
6 and the second conductor at the second contact location is at least substantially equal to
7 the change in the straight resistance component between the first conductor at the corner
8 and the second conductor at the second contact location.

1 20. The variable resistance device of claim 1 wherein the distance
2 between the first contact location and the second contact location is at least substantially
3 constant and the straight resistance component is at least substantially constant, so that the
4 change in the resistance between the first conductor at the first contact location and the
5 second conductor at the second contact location is at least substantially equal to the
6 change in the parallel path resistance component between the first conductor at the first
7 contact location and the second conductor at the second contact location.

1 21. The variable resistance device of claim 20 wherein at least one of
2 the first and second contact areas is variable, the parallel path resistance component
3 generally decreasing with an increase in at least one of the first and second contact areas.

1 22. The variable resistance device of claim 21 wherein the resistive
2 member has a variable resistive footprint which contacts the first and second conductors
3 with at least one of a variable first contact area and a variable second contact area.

1 23. The variable resistance device of claim 21 wherein the first
2 conductor has a first edge and the second conductor has a second edge which is spaced

3 from the first edge by a distance that is at least substantially constant; and wherein the
4 resistive member has a resistive footprint which makes movable contact with the first and
5 second conductors across the first edge and the second edge to produce at least one of a
6 variable first contact area and a variable second contact area.

1 24. The variable resistance device of claim 23 wherein the resistive
2 footprint is at least substantially constant in size; and wherein at least one of the first and
3 second conductors has a nonuniform contact surface for making movable contact with the
4 resistive footprint to produce at least one of a variable first contact area and a variable
5 second contact area.

1 25. The variable resistance device of claim 23 wherein the at least one
2 of a variable first contact area and a variable second contact area increases continuously
3 in a direction of movable contact between the resistive footprint and the first and second
4 conductors, the parallel path resistance component between the first conductor and the
5 second conductor decreasing in the direction of movable contact.

1 26. The variable resistance device of claim 25 wherein the at least one
2 of a variable first contact area and a variable second contact area increases in such a
3 manner that the parallel path resistance component between the first conductor and the
4 second conductor decreases substantially linearly in the direction of movable contact.

1 27. The variable resistance device of claim 23 wherein the resistive
2 footprint is at least substantially circular or rectangular or triangular.

1 28. The variable resistance device of claim 21 wherein the resistive
2 member has a resistive footprint which is deformable to make variable contact with the
3 first and second conductors so as to produce at least one of a variable first contact area
4 and a variable second contact area.

1 29. The variable resistance device of claim 1 wherein the first and
2 second contact locations and first and second contact areas are selected such that the
3 parallel path resistance component is substantially larger than the straight resistance
4 component and the change in the resistance between the first conductor at the first contact
5 location and the second conductor at the second contact location is at least substantially

6 equal to the change in the parallel path resistance component between the first conductor
7 and the second conductor.

1 30. The variable resistance device of claim 29 wherein the resistive
2 member has a resistive surface with an outer boundary contacting the first and second
3 conductors at the first and second contact locations, respectively, the first and second
4 contact locations being disposed away from the outer boundary of the resistive surface.

1 31. The variable resistance device of claim 30 wherein the first contact
2 location is at least substantially fixed on the resistive surface.

1 32. The variable resistance device of claim 31 wherein the second
2 contact location is movable on the resistive surface relative to the first contact location.

1 33. The variable resistance device of claim 32 wherein the parallel path
2 resistance component between the first conductor at the first contact location and the
3 second conductor at the second contact location decreases with an increase in a distance
4 between the first contact location and the second contact location.

1 34. The variable resistance device of claim 33 wherein the parallel path
2 resistance component decreases in a substantially linear manner with an increase in the
3 distance between the first contact location and the second contact location over at least a
4 portion of the resistive surface.

1 35. The variable resistance device of claim 32 wherein the first contact
2 area at the first contact location is at least substantially constant and the second contact
3 area at the second contact location is at least substantially constant.

1 36. The variable resistance device of claim 31 wherein the first contact
2 location is fixed generally in a central region of the resistive surface.

1 37. The variable resistance device of claim 36 wherein the second
2 conductor includes a second conductor surface; and wherein at least one of the resistive
3 surface and the second conductor surface comprises a convex, curved surface to provide
4 rolling contact between the resistive surface and the second conductor surface.

1 38. The variable resistance device of claim 37 wherein the second
2 conductor surface includes a conductive portion and a nonconductive portion, the
3 conductive portion increasing in proportion and the nonconductive portion decreasing in
4 proportion with an increase in distance from the first contact location over at least a part
5 of the second conductive surface.

1 39. The variable resistance device of claim 38 wherein the conductive
2 portion gradually increases in proportion and the nonconductive portion gradually
3 decreases in proportion with an increase in distance from the first contact location.

1 40. The variable resistance device of claim 37 wherein one of the
2 resistive surface and the second conductor surface comprises a convex, curved surface,
3 and the other one of the resistive surface and the second conductor surface comprises a
4 substantially planar surface.

1 41. The variable resistance device of claim 37 wherein the second
2 conductor surface is generally annular with an outer boundary and an inner boundary, the
3 inner boundary of the second conductor surface being spaced from the first contact
4 location on the resistive surface.

1 42. The variable resistance device of claim 36 wherein the resistive
2 member is resiliently supported at the first contact location by a spring.

1 43. The variable resistance device of claim 42 wherein the first
2 conductor comprises the spring.

1 44. The variable resistance device of claim 36 wherein the first
2 conductor is energized with a voltage.

1 45. The variable resistance device of claim 30 wherein the distance
2 between the first and second contact locations is at least substantially fixed and the
3 parallel path resistance component generally decreases with an increase in at least one of
4 the first contact area at the first contact location and the second contact area at the second
5 contact location.

1 46. The variable resistance device of claim 45 wherein the first and
2 second contact locations are at least substantially fixed.

1 47. The variable resistance device of claim 45 wherein the first contact
2 location is fixed generally in a central region of the resistive surface.

1 48. The variable resistance device of claim 45 wherein the resistive
2 surface is deformable to make variable contact with the first and second conductors to
3 produce at least one of a variable first contact area and a variable second contact area, the
4 parallel path resistance component between the first conductor at the first contact location
5 and the second conductor at the second contact location generally decreasing with an
6 increase in at least one of the first and second contact areas.

1 49. The variable resistance device of claim 1 wherein the resistive
2 member has a resistive surface for contacting the first and second conductors at the first
3 and second contact locations, respectively, the resistive surface having an outer boundary
4 and a thickness which is substantially smaller than a square root of a surface area of the
5 resistive surface; wherein the parallel path resistance component between the first
6 conductor at the first contact location and the second conductor at the second contact
7 location is substantially larger than the straight resistance component when both the first
8 and second contact locations are disposed away from the outer boundary of the resistive
9 surface; and wherein the straight resistance component between the first conductor at the
10 first contact location and the second conductor at the second contact location is
11 substantially larger than the parallel path resistance component when at least one of the
12 first and second contact locations is at or near the outer boundary of the resistive surface.

1 50. The variable resistance device of claim 49 wherein the first contact
2 location is fixed generally in a central region of the resistive surface.

1 51. The variable resistance device of claim 50 wherein the second
2 contact location is movable relative to the first contact location, the straight resistance
3 component between the first conductor at the first contact location and the second
4 conductor at the second contact location increasing with an increase in distance between
5 the first contact location and the second contact location, the parallel path resistance
6 component between the first conductor at the first contact location and the second

7 conductor at the second contact location decreasing with an increase in distance between
8 the first contact location and the second contact location.

1 52. The variable resistance device of claim 51 wherein the first contact
2 area at the first contact location is at least substantially constant and the second contact
3 area at the second contact location is at least substantially constant.

1 53. The variable resistance device of claim 52 wherein the resistance
2 between the first conductor at the first contact location and the second conductor at the
3 second contact location decreases initially as the distance between the first contact
4 location and the second contact location increases until the second contact location
5 approaches closely toward the boundary location, whereupon the resistance increases
6 until the second contact location reaches the boundary of the resistive surface.

1 54. The variable resistance device of claim 49 wherein the first contact
2 location is disposed at or near the boundary of the resistive surface; and wherein the
3 second contact location is movable on the resistive surface, the resistance between the
4 first conductor at the first contact location and the second conductor at the second contact
5 location increasing with an increases in distance between the first contact location and the
6 second contact location.

1 55. The variable resistance device of claim 1 wherein the resistance
2 between the first conductor at the first contact location and the second conductor at the
3 second contact location increases when the resistive member undergoes a stretching
4 deformation between the first contact location and the second contact location.

1 56. The variable resistance device of claim 1 wherein the resistance
2 between the first conductor at the first contact location and the second conductor at the
3 second contact location decreases when the resistive member is subject to a pressure
4 between the first contact location and the second contact location.

1 57. The variable resistance device of claim 1 wherein the resistance
2 between the first conductor at the first contact location and the second conductor at the
3 second contact location increases when the resistive member undergoes a rise in
4 temperature between the first contact location and the second contact location and

5 decreases when the resistive member undergoes a drop in temperature between the first
6 contact location and the second contact location.

1 58. A method of providing a variable resistance from a resistive
2 member including a resistive rubber material, the method comprising:
3 electrically coupling a first conductor with the resistive member at a first
4 location over a first contact area;
5 electrically coupling a second conductor with the resistive member at a
6 second location over a second contact area;
7 changing at least one of the first location, the second location, the first
8 contact area, and the second contact area to produce a change in resistance between the
9 first conductor and the second conductor, the resistance between the first conductor and
10 the second conductor including a straight resistance component and a parallel path
11 resistance component, the straight resistance component increasing as the distance
12 between the first location and the second location increases and decreasing as the distance
13 between the first location and the second location decreases, the parallel path resistance
14 component having preset desired characteristics based on selected first and second
15 locations and selected first and second contact areas.

1 59. The method of claim 58 wherein the first and second locations and
2 first and second contact areas are selected to provide a parallel path resistance component
3 which is at least substantially constant with respect to changes in the distance between the
4 first location and the second location, so that the resistance between the first conductor at
5 the first location and the second conductor at the second location increases as the distance
6 between the first location and the second location increases and decreases as the distance
7 between the first location and the second location decreases.

1 60. The method of claim 58 wherein the first and second locations and
2 first and second contact areas are selected such that the straight resistance component is
3 substantially larger than the parallel path resistance component and the change in the
4 resistance between the first conductor at the first location and the second conductor at the
5 second location is at least substantially equal to the change in the straight resistance
6 component between the first conductor and the second conductor.

1 61. The method of claim 58 wherein the distance between the first
2 location and the second location is at least substantially constant and the straight
3 resistance component is at least substantially constant, so that the change in the resistance
4 between the first conductor at the first location and the second conductor at the second
5 location is at least substantially equal to the change in the parallel path resistance
6 component between the first conductor at the first location and the second conductor at
7 the second location.

1 62. The method of claim 58 wherein the first and second locations and
2 first and second contact areas are selected such that the parallel path resistance
3 component is substantially larger than the straight resistance component and the change in
4 the resistance between the first conductor at the first location and the second conductor at
5 the second location is at least substantially equal to the change in the parallel path
6 resistance component between the first conductor and the second conductor.

1 63. The method of claim 58 further comprising the step of stretching
2 the resistive member between the first location and the second location to increase the
3 resistance between the first conductor at the first location and the second conductor at the
4 second location.

1 64. The method of claim 58 further comprising the step of applying a
2 pressure on the resistive member between the first contact location and the second location
3 to decrease the resistance between the first conductor at the first location and the second
4 conductor at the second location.

1 65. The method of claim 58 further comprising the step of increasing
2 the temperature of the resistive member between the first location and the second location
3 to increase the resistance between the first conductor at the first location and the second
4 conductor at the second location or decreasing the temperature of the resistive member
5 between the first location and the second location to decrease the resistance between the
6 first conductor at the first location and the second conductor at the second location.

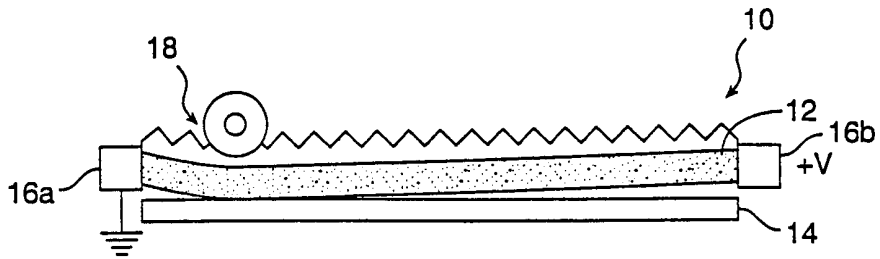

FIG. 1A

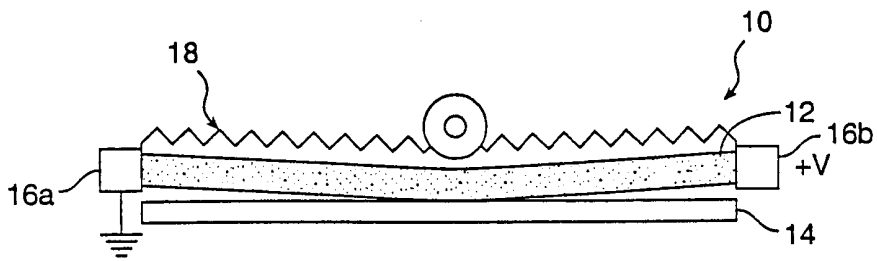

FIG. 1B

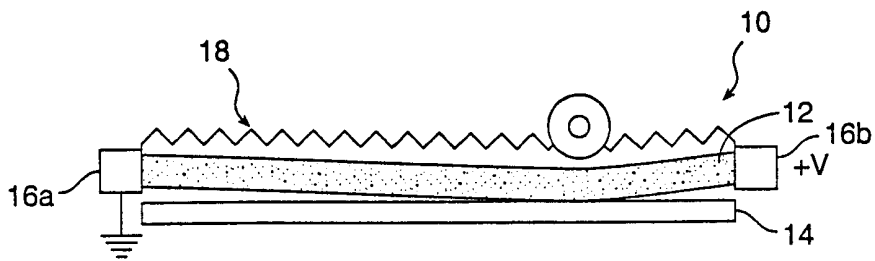

FIG. 1C

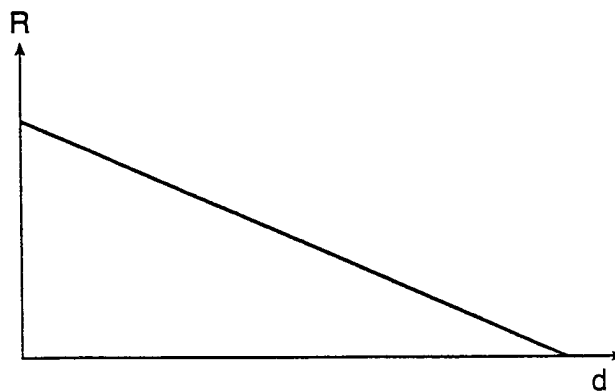

FIG. 1D

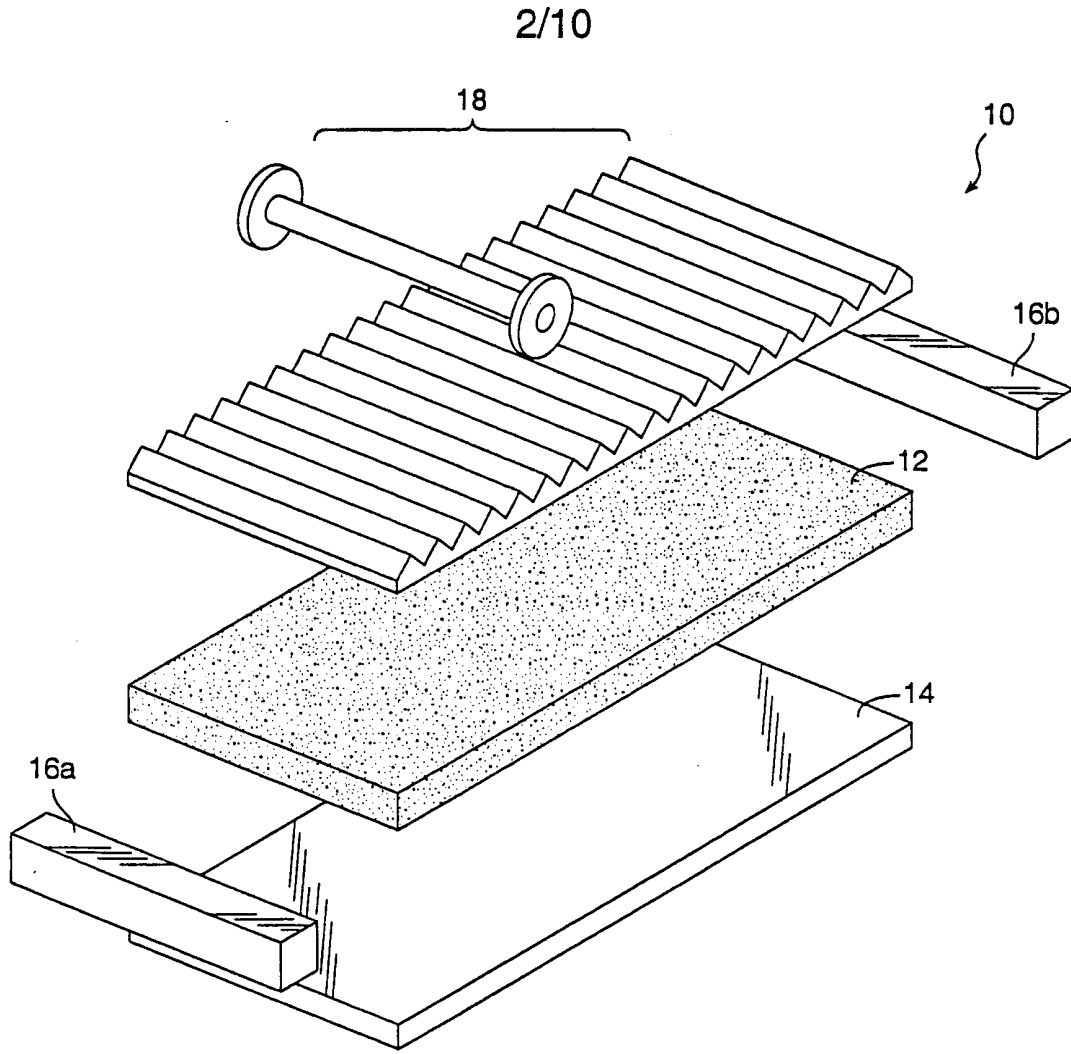

FIG. 2

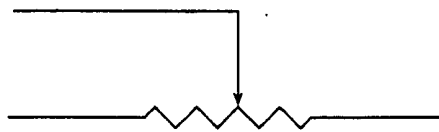

FIG. 3

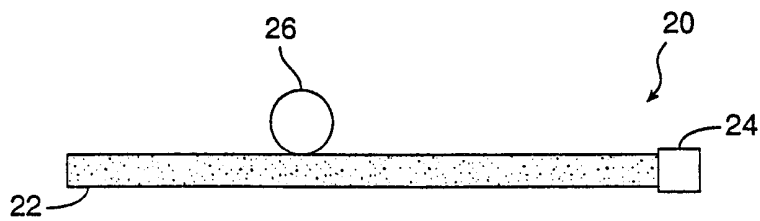

FIG. 4

3/10

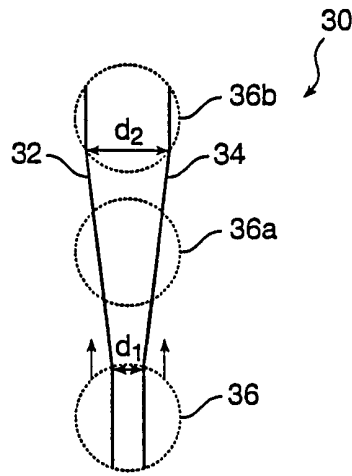

FIG. 5A

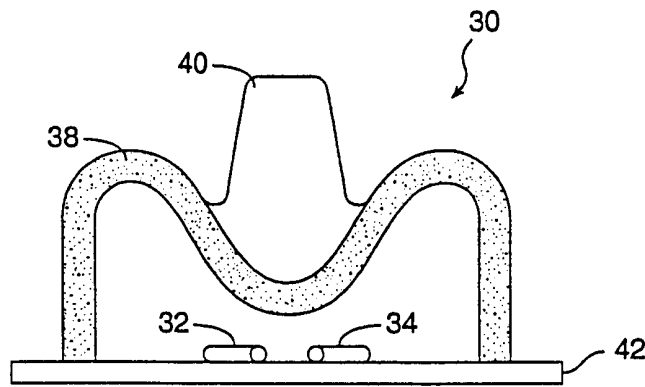

FIG. 5B

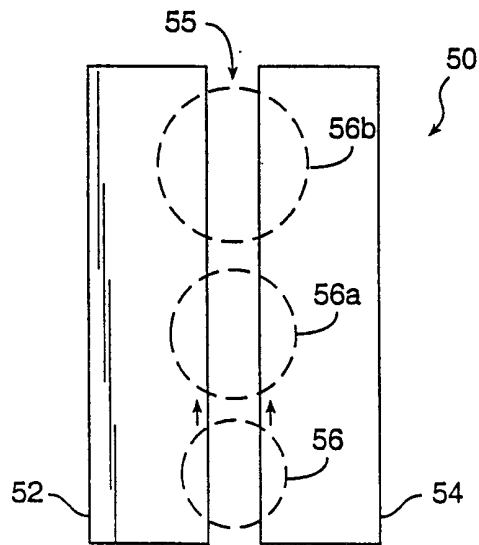

FIG. 6A

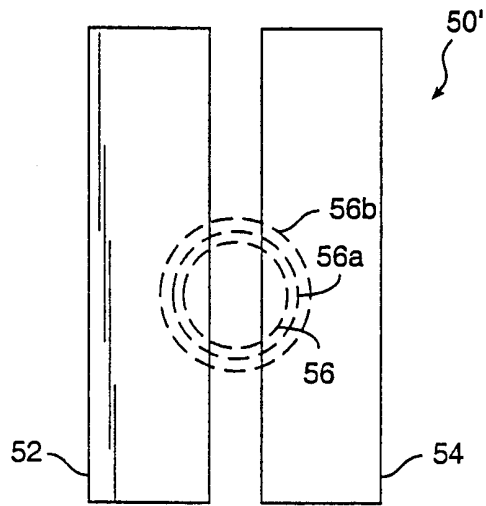

FIG. 6B

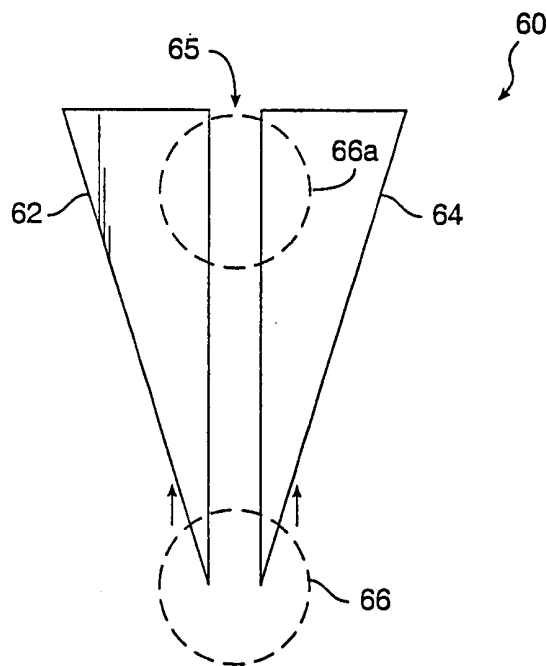

FIG. 7

5/10

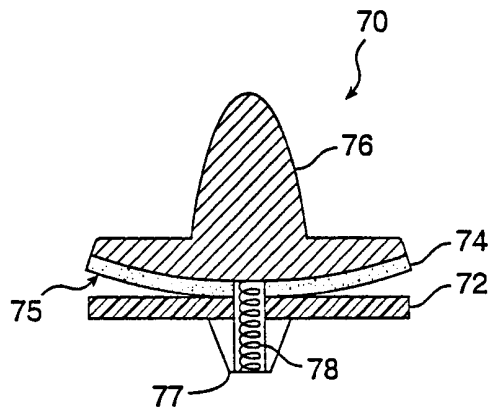

FIG. 8

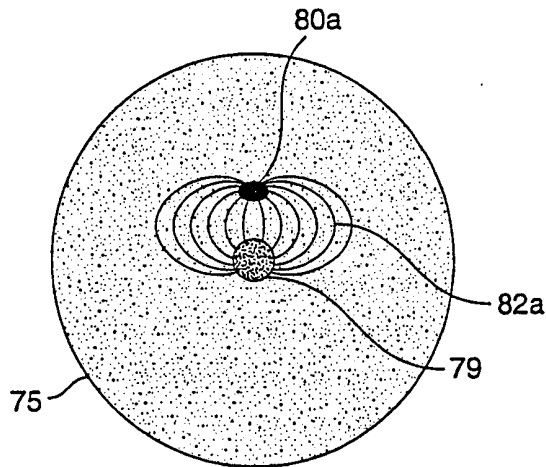

FIG. 9A

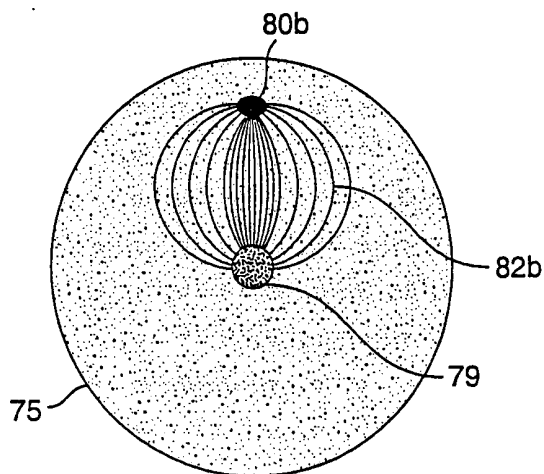

FIG. 9B

6/10

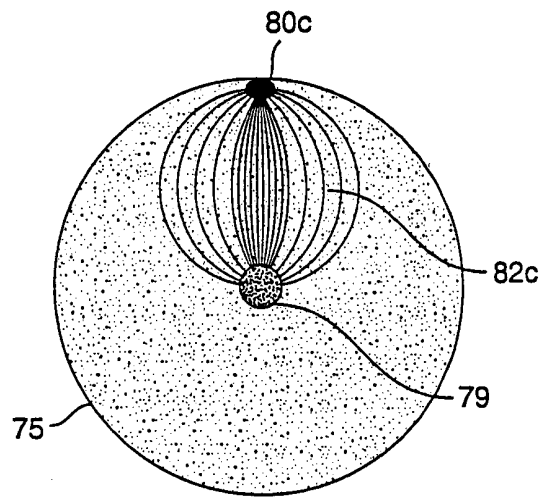

FIG. 9C

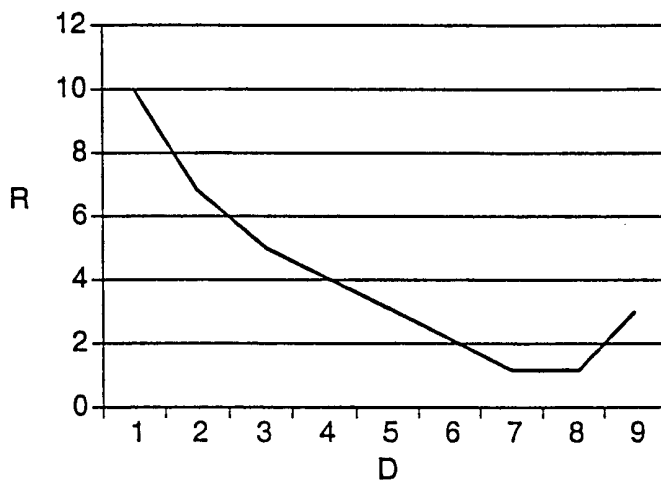

FIG. 10

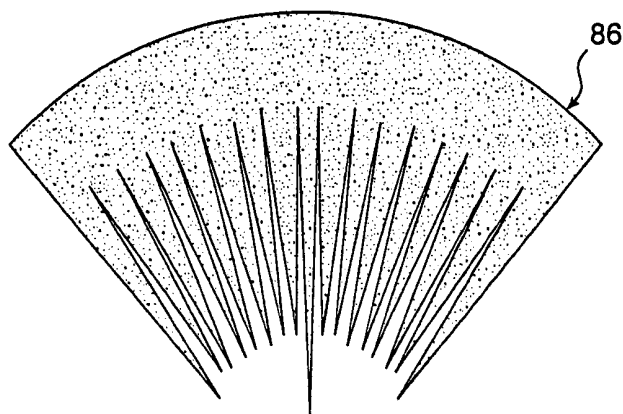

FIG. 11A

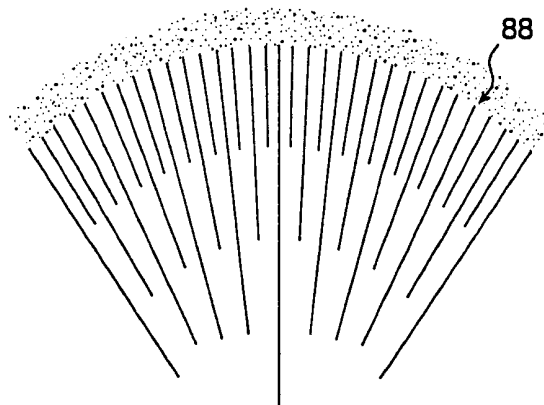

FIG. 11B

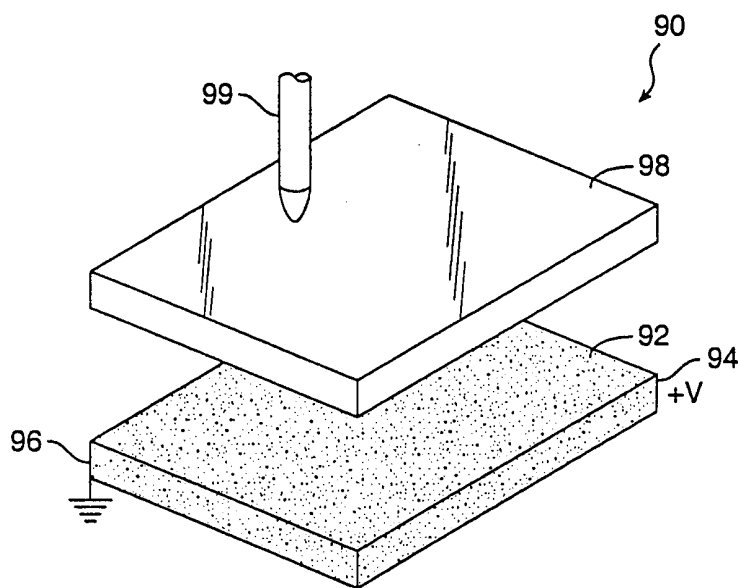

FIG. 12

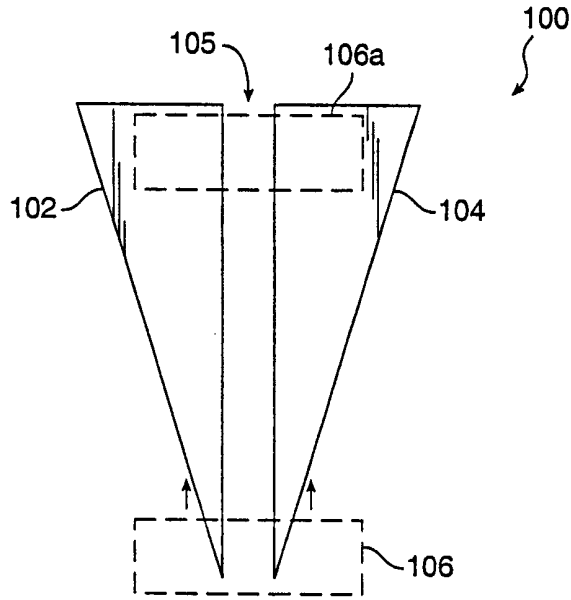

FIG. 13

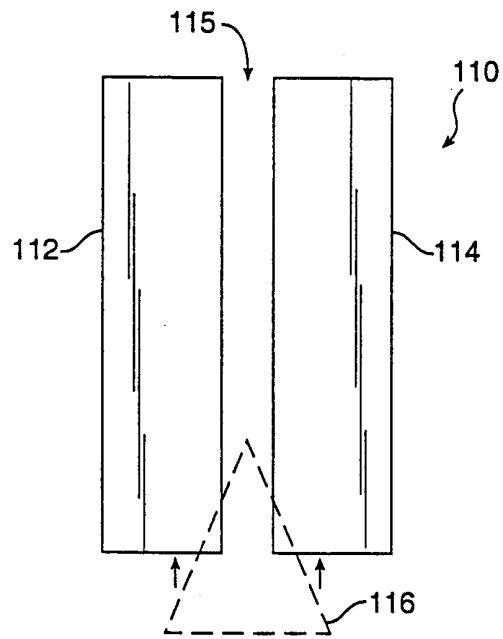

FIG. 14

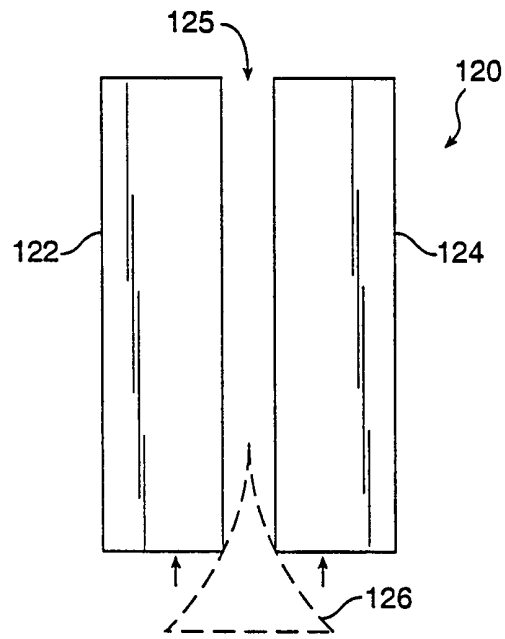

FIG. 15

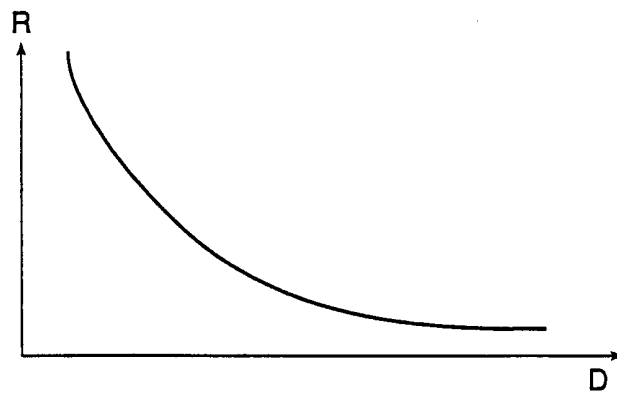

FIG. 16

10/10

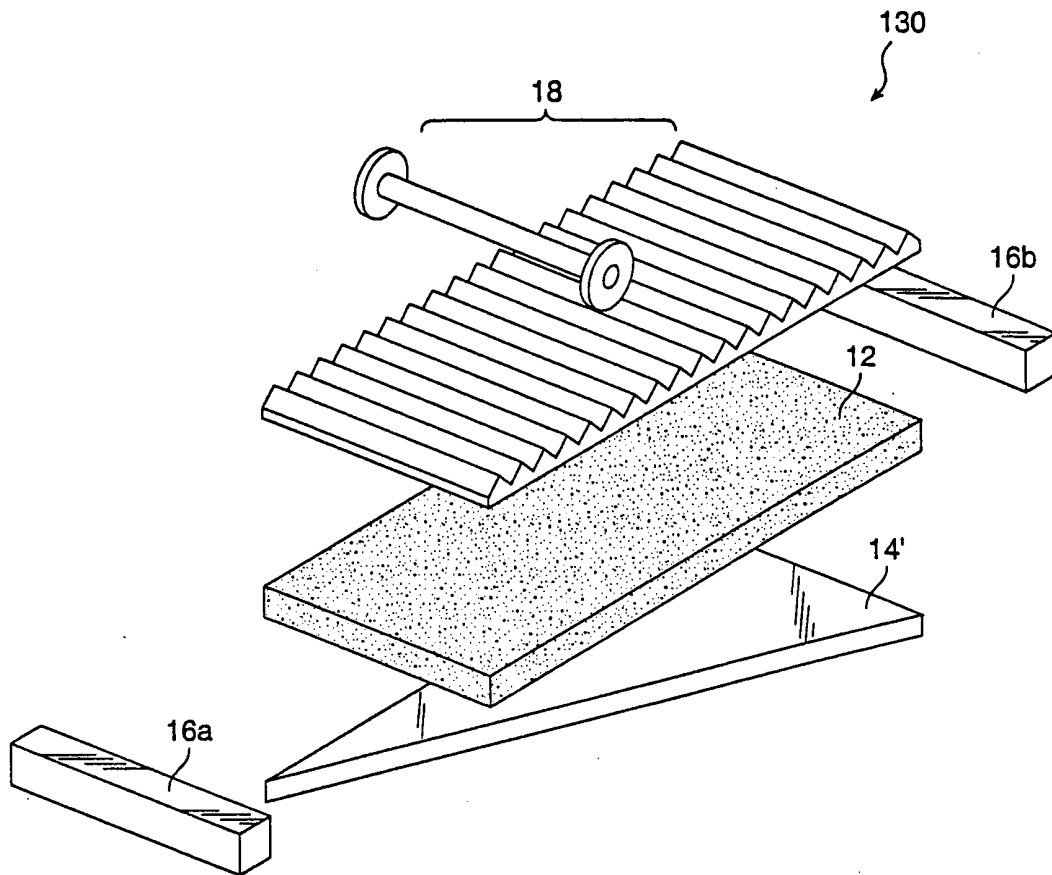

FIG. 17

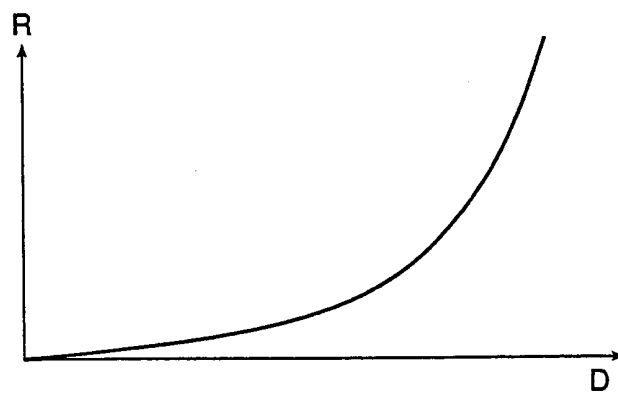

FIG. 18

INTERNATIONAL SEARCH REPORT

International application No.
PCT/US00/13032

A. CLASSIFICATION OF SUBJECT MATTER

IPC(7) :HOIC 10/06
US CL :338/92,96, 97, 158

According to International Patent Classification (IPC) or to both national classification and IPC

B. FIELDS SEARCHED

Minimum documentation searched (classification system followed by classification symbols)

U.S. : 338/92,96,97,158

Documentation searched other than minimum documentation to the extent that such documents are included in the fields searched

NONE

Electronic data base consulted during the international search (name of data base and, where practicable, search terms used)

NONE

C. DOCUMENTS CONSIDERED TO BE RELEVANT

Category*	Citation of document, with indication, where appropriate, of the relevant passages	Relevant to claim No.
X	US 5,644,283 A (GROSSE-WILDE et al.) 01 July 1997, (01/07/97) Figs. 2-3, 6, abstract.	1,18,19, 55-58, 65.
X	US 5,675,309 A (DeVOLPI) 07 October 1997, (07/10/97) Figs. 4-7, 13.	1-8, 10-18, 20-56, 58-64.
X	US 4,745,301 A (MICHALCHIK) 17 May 1988, (17/05/88) Figs. 3-4.	1, 55-56.
X	US 4,878,040 A (TAMURA) 31 October 1989, (31/10/89) Fig. 1.	1-3, 9, 58-62.

Further documents are listed in the continuation of Box C.

See patent family annex.

<p>* Special categories of cited documents:</p> <p>"A" document defining the general state of the art which is not considered to be of particular relevance</p> <p>"E" earlier document published on or after the international filing date</p> <p>"L" document which may throw doubts on priority claim(s) or which is cited to establish the publication date of another citation or other special reason (as specified)</p> <p>"O" document referring to an oral disclosure, use, exhibition or other means</p> <p>"P" document published prior to the international filing date but later than the priority date claimed</p>	<p>"T" later document published after the international filing date or priority date and not in conflict with the application but cited to understand the principle or theory underlying the invention</p> <p>"X" document of particular relevance; the claimed invention cannot be considered novel or cannot be considered to involve an inventive step when the document is taken alone</p> <p>"Y" document of particular relevance; the claimed invention cannot be considered to involve an inventive step when the document is combined with one or more other such documents, such combination being obvious to a person skilled in the art</p> <p>"&" document member of the same patent family</p>
--	---

Date of the actual completion of the international search

10 JULY 2000

Date of mailing of the international search report

25 JUL 2000

Name and mailing address of the ISA/US
Commissioner of Patents and Trademarks
Box PCT
Washington, D.C. 20231

Facsimile No. (703) 305-3230

Authorized officer

KARL EASTHOM *Macceleso*

Telephone No. (703) 308-3306