

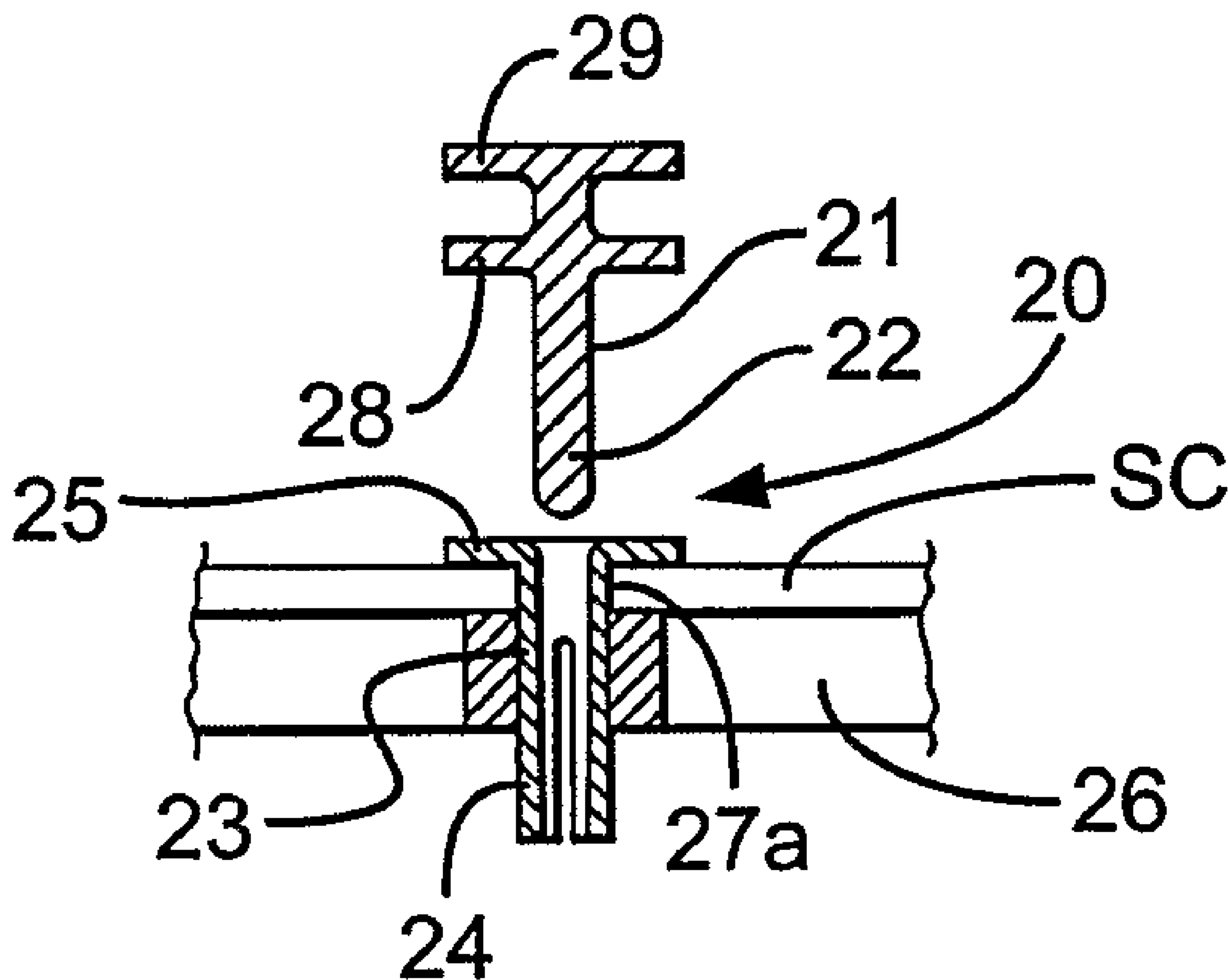

(86) Date de dépôt PCT/PCT Filing Date: 2003/01/16
 (87) Date publication PCT/PCT Publication Date: 2003/07/31
 (45) Date de délivrance/Issue Date: 2008/12/30
 (85) Entrée phase nationale/National Entry: 2004/06/30
 (86) N° demande PCT/PCT Application No.: GB 2003/000208
 (87) N° publication PCT/PCT Publication No.: 2003/061855
 (30) Priorité/Priority: 2002/01/16 (US10/053,350)

(51) Cl.Int./Int.Cl. *B07B 1/46* (2006.01),
B01D 33/03 (2006.01), *B07B 1/48* (2006.01)
 (72) Inventeurs/Inventors:
ADAMS, THOMAS COLE, US;
MCCLUNG, GUY LAMONT III, US
 (73) Propriétaire/Owner:
VARCO I/P, INC., US
 (74) Agent: MCFADDEN, FINCHAM

(54) Titre : SEPARATEUR DE MATERIAUX
 (54) Title: AN APPARATUS FOR SEPARATING MATERIAL



(57) Abrégé/Abstract:

An apparatus for separating material, said apparatus comprising a shale shaker and a screen assembly characterised in that said screen assembly (SC) comprises a plurality of holes (27a) and said shale shaker comprises holes (27) or recesses, the apparatus

(57) **Abrégé(suite)/Abstract(continued):**

further comprising a plurality of fasteners (20) for releasably connecting said screen assembly to said shale shaker through said plurality of holes.

(12) INTERNATIONAL APPLICATION PUBLISHED UNDER THE PATENT COOPERATION TREATY (PCT)

(19) World Intellectual Property Organization
International Bureau(43) International Publication Date
31 July 2003 (31.07.2003)

PCT

(10) International Publication Number
WO 03/061855 A1

- (51) International Patent Classification⁷: **B07B 1/46**, 1/48, B01D 33/03
- (21) International Application Number: PCT/GB03/00208
- (22) International Filing Date: 16 January 2003 (16.01.2003)
- (25) Filing Language: English
- (26) Publication Language: English
- (30) Priority Data:
10/053,350 16 January 2002 (16.01.2002) US
- (71) Applicants (for all designated States except US): **VARCO I/P, INC.** [US/US]; 2835 Holmes Road, Houston, TX 77051 (US). **LUCAS, BRIAN RONALD** [GB/GB]; Lucas & Co., 135 Westhall Road, Warlingham, Surrey CR6 9HJ (GB).
- (72) Inventors; and
- (75) Inventors/Applicants (for US only): **ADAMS, Thomas, Cole** [US/US]; 27306 Teepee Trail, Hockley, TX 77447 (US). **MCCLUNG III, Guy, Lamont** [US/US]; 18007 Pleasant Wood, Spring, TX 77379 (US).
- (74) Agent: **LUCAS, BRIAN RONALD**; Lucas & Co., 135 Westhall Road, Warlingham, Surrey CR6 9HJ (GB).
- (81) Designated States (*national*): AE, AG, AL, AM, AT, AU, AZ, BA, BB, BG, BR, BY, BZ, CA, CH, CN, CO, CR, CU, CZ, DE, DK, DM, DZ, EC, EE, ES, FI, GB, GD, GE, GH, GM, HR, HU, ID, IL, IN, IS, JP, KE, KG, KP, KR, KZ, LC, LK, LR, LS, LT, LU, LV, MA, MD, MG, MK, MN, MW, MX, MZ, NO, NZ, OM, PH, PL, PT, RO, RU, SC, SD, SE, SG, SK, SL, TJ, TM, TN, TR, TT, TZ, UA, UG, US, UZ, VC, VN, YU, ZA, ZM, ZW.
- (84) Designated States (*regional*): ARIPO patent (GH, GM, KE, LS, MW, MZ, SD, SL, SZ, TZ, UG, ZM, ZW), Eurasian patent (AM, AZ, BY, KG, KZ, MD, RU, TJ, TM), European patent (AT, BE, BG, CH, CY, CZ, DE, DK, EE, ES, FI, FR, GB, GR, HU, IE, IT, LU, MC, NL, PT, SE, SI, SK, TR), OAPI patent (BF, BJ, CF, CG, CI, CM, GA, GN, GQ, GW, ML, MR, NE, SN, TD, TG).
- Declaration under Rule 4.17:**
— of inventorship (Rule 4.17(iv)) for US only
- Published:**
— with international search report
- For two-letter codes and other abbreviations, refer to the "Guidance Notes on Codes and Abbreviations" appearing at the beginning of each regular issue of the PCT Gazette.*

(54) Title: AN APPARATUS FOR SEPARATING MATERIAL

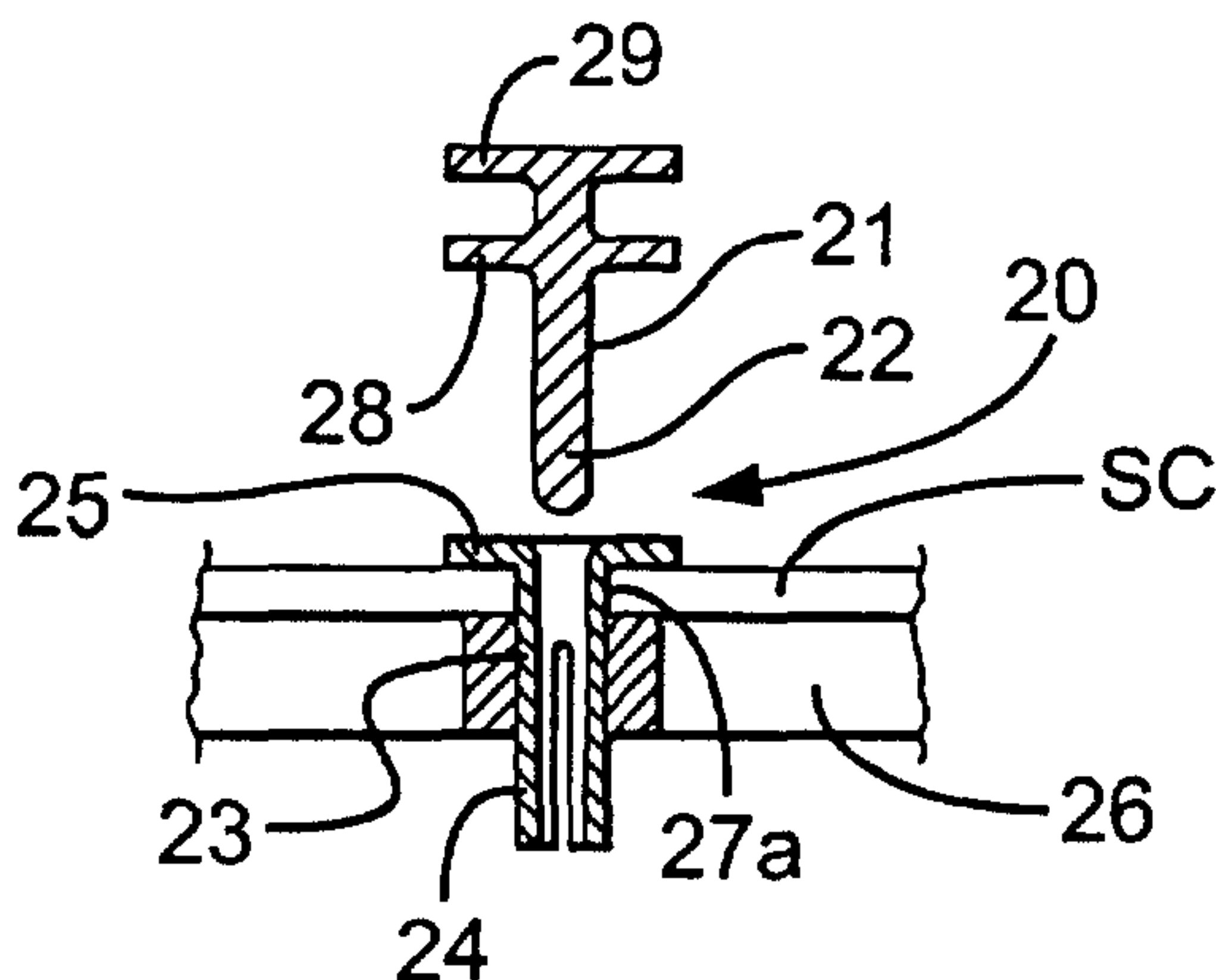

(57) Abstract: An apparatus for separating material, said apparatus comprising a shale shaker and a screen assembly characterised in that said screen assembly (SC) comprises a plurality of holes (27a) and said shale shaker comprises holes (27) or recesses, the apparatus further comprising a plurality of fasteners (20) for releaseably connecting said screen assembly to said shale shaker through said plurality of holes.



WO 03/061855 A1

AN APPARATUS FOR SEPARATING MATERIAL

The present invention relates to an apparatus for separating solids from a solids laden drilling mud, a screen assembly and a method for replacing a screen in a shale shaker.

In the drilling of a borehole in the construction of an oil or gas well, a drill bit is arranged on the end of a drill string and is rotated to bore the borehole. A drilling fluid known as "drilling mud" is pumped through the drill string to the drill bit to lubricate the drill bit. The drilling mud is also used to carry the cuttings produced by the drill bit and other solids to the surface through an annulus formed between the drill string and the borehole. The drilling mud contains expensive synthetic oil-based lubricants and it is normal therefore to recover and re-use the used drilling mud, but this requires the solids to be removed from the drilling mud. This is achieved by processing the drilling fluid. The first part of the process is to separate the solids from the solids laden drilling mud. This is at least partly achieved with a vibratory separator, such as those shale shakers disclosed in US 5,265,730, WO 96/33792 and WO 98/16328.

Shale shakers generally comprise an open bottomed basket having one open discharge end and a solid walled feed end. A number of rectangular screens are arranged in the basket, which are held in C-channel rails located on the basket walls, such as those disclosed in GB-A-2,176,425. The basket is arranged on springs above a receptor for receiving recovered drilling mud. A skip or ditch is provided beneath the open discharge end of the basket. A motor is fixed to the basket, which has a drive rotor provided with an offset clump weight. In use, the motor rotates the rotor and the offset clump weight,

- 2 -

which causes the basket and the screens fixed thereto to shake. Solids laden mud is introduced at the feed end of the basket on to the screens. The shaking motion induces the solids to move along the screens towards the open
5 discharge end. The recovered drilling mud is received in the receptor for further processing and the solids pass over the discharge end of the basket into the ditch or skip.

The prior art discloses a variety of mounting
10 systems and apparatuses for releasably mounting a screen assembly to a shale shaker. These include drawbar and hookstrip apparatuses; inflatable device systems (as described above); wedge systems; for example, the systems described in US-A-6,179,128 issued Jan 30, 2001; US-A-
15 5,392,925 issued Feb. 28, 1995; US-A-4,882,054 issued Nov. 21, 1989; US-A-4,582,597 issued Apr. 15, 1986; and in the prior art referred to in each of these references.

A prior art shale shaker is shown in Figure 5. The shale shaker 1 has a screen 2 (with screen or screening
20 cloth or mesh as desired) mounted on vibratable screen mounting apparatus or "basket" 3. The screen 2 may be any known screen or screens. The basket 3 is mounted on springs 4 (only two shown; two as shown are on the opposite side) which are supported from a frame 6. The
25 basket 3 is vibrated by a motor 5 and interconnected vibrating apparatus 8 which is mounted on the basket 3 for vibrating the basket and the screens. Elevator apparatus 7 provides for raising and lowering of the basket end.

30 Figure 6 discloses an example of a prior art shaker system (for example as shown in US-A-5,190,645). The system A has a shale shaker K having a screen or screens S. The screen(s) S are mounted in a typical shaker basket B and one or more vibrators V (any known suitable
35 shaker vibrator) vibrate the basket B and hence the

- 3 -

screen(s) S. The other components of the system A are as described in US-A-5,190,645.

The screens are generally of one of two types: hook-strip; and pre-tensioned.

5 The hook-strip type of screen comprises several rectangular layers of mesh in a sandwich, usually comprising one or two layers of fine grade mesh and a supporting mesh having larger mesh holes and heavier gauge wire. The layers of mesh are joined at each side
10 edge by a strip which is in the form of an elongate hook. In use, the elongate hook is hooked on to a tensioning device arranged along each side of a shale shaker. The shale shaker further comprises a crowned set of supporting members, which run along the length of the
15 basket of the shaker, over which the layers of mesh are tensioned. An example of this type of screen is disclosed in GB-A-1,526,663. The supporting mesh may be provided with or replaced by a panel having apertures therein.

 The pre-tensioned type of screen comprises several
20 rectangular layers of mesh, usually comprising one or two layers of fine grade mesh and a supporting mesh having larger mesh holes and heavier gauge wire. The layers of mesh are pre-tensioned on a rigid support comprising a rectangular angle iron frame and adhered thereto. The
25 screen is then inserted into C-channel rails arranged in a basket of a shale shaker. An example of this type of screen is disclosed in GB-A-1,578,948.

 A further example of a known rigid support is disclosed in PCT Publication No. WO 01/76719, which
30 discloses, amongst other things, a flat panel like portion having apertures therein and wing portions which are folded to form a support structure, which may be made from a single sheet of material. This rigid support has been assigned the Trade Mark "UNIBODY" by the applicants.

35 The layers of mesh in the screens wears out

- 4 -

frequently and therefore needs to be easily replaceable. Shale shakers are generally in the order of 5ft (1.5m) wide and 10ft long (3m). A screen of dimensions 4ft (1.2m) wide by 10ft (3m) long is difficult to handle, replace and transport. It is known to use two, three, four or more screens in a single shale shaker. A standard size of screen currently used is of the order of 4ft (1.2m) by 3ft (0.9m).

There is a need, recognized by the present inventors, for an efficient and effective screen support and screen assembly for a shale shaker. There is a need, recognized by the present inventors, for an efficient and cost-effective screen support and screens with such a support that are easily installed and which are easily repairable. There has long been a need for a relatively light weight screen assembly which can be easily handled and manipulated manually by personnel. There has long been a need, recognized by the present inventors, for a screen assembly none of whose portions is blocked by parts of a support frame beneath screening material; and for such a screen assembly which is easily plugged for repair.

In accordance with the present invention, there is provided an apparatus for separating solids from a solids laden drilling mud, the apparatus comprising a shale shaker having a screen deck arranged in a basket, the basket having walls and a screen assembly spanning between the walls of the basket, the screen assembly having two spaced-apart ends spanning between the walls of the basket the screen assembly comprising a support comprising a perforate plate and at least one layer of screening material tensioned thereon and fixed thereto characterised in that, the screen deck comprises a plurality of holes or recesses and the screen assembly comprises a plurality of corresponding holes in the

- 5 -

interior of said screen assembly between the spaced-apart ends, the apparatus further comprising a plurality of fasteners for releaseably connecting the screen assembly to the shale shaker through the plurality of holes.

5 Certain of these holes through which fasteners are inserted may be made so that there is relatively more area and mass around each hole.

Preferably, the support comprises a series of spaced apart strips. Advantageously, the support comprises an
10 outer frame. Preferably, the frame further comprises cross-members spanning the outer frame. Advantageously, the support perforate plate has wing portions which are folded to form a support structure, this support structure is referred to by the applicants under the
15 trademark UNIBODY.

Preferably, the screen assembly has two spaced-apart ends and the plurality of spaced-apart holes extend through the two spaced-apart ends. Advantageously, the screen assembly has an interior and the holes of the
20 plurality of holes extend through the interior of the screen assembly.

Advantageously, the screen assembly comprises at least one layer of screening material, the plurality of holes which pass through the screening material.
25 Preferably, the at least one layer of screening material comprises a plurality of layers of screening mesh.

Preferably, the screen assembly further comprises a plastic grid with holes therethrough corresponding in position to at least a portion of the holes of the
30 plurality of spaced-apart holes of the screen assembly so that fasteners are passable through the holes of the plastic grid.

Screens according to certain aspects of the present invention may be made with plastic grids or fused plastic
35 masses with holes, etc. that correspond to the fastener

- 6 -

holes, etc. of a support in accordance with the present invention.

Advantageously, the screen assembly comprises flat layers of screening material. Alternatively or
5 additionally, the screen assembly comprises an undulating layer of screening material comprising undulations with ridges and valleys.

Preferably, the fasteners are from the group consisting of threaded fasteners, bolts, locking
10 fasteners, finger expansion fasteners, air injection fasteners, and friction-fit fasteners.

Preferably, the fasteners are secured to the screen assembly. Advantageously, the fasteners are secured to the shale shaker.

15 The present invention also provides for use in a shale shaker for separating solids from a solids laden drilling fluid, a screen assembly having two spaced-apart ends comprising a support comprising a perforate plate and at least one layer of screening material tensioned
20 thereon and fixed thereto and wherein said screen assembly comprises a plurality of holes in the interior of said screen assembly between the spaced-apart ends which, in use, correspond to a plurality of holes or recesses in a screen deck of a shale shaker for
25 releaseably connecting said screen assembly to said shale shaker with a plurality of fasteners through said plurality of holes.

The invention also provides a method for replacing a screen assembly in a shale shaker, the shale shaker
30 comprising a basket and a screen deck arranged in the basket, the basket having walls, the screen deck having a plurality of holes or recesses, the screen assembly having two ends spanning between the walls of the basket, the screen assembly comprising a support and at least one
35 layer of screening material tensioned thereon and fixed

- 7 -

thereto the screening assembly having a plurality of corresponding holes in the interior of the screen assembly between the two spaced-apart ends, the method comprising the step of fastening the screen assembly to
5 the screen deck through the plurality of holes with a fastener.

10

- 8 -

For a better understanding of the present invention, reference will now be made, by way of example, to the accompanying drawings, in which:

5 Figure 1A is a top plan view of a screen assembly in accordance with the present invention with a screen support in accordance with the present invention;

Figure 1B is a side view of the screen assembly of Figure 1A.

10 Figures 2A is a side view in cross-section of fastener system for use in releasably connecting a screen assembly in accordance with the present invention to a shale shaker;

Fig 2B shows the fastener of Figure 2A in position connecting a screen assembly to a shale shaker;

15 Figure 3A is a side view in cross-section of fastener system for use in releasably connecting a screen assembly in accordance with the present invention to a shale shaker;

20 Figure 3B shows the fastener of Figure 3A in position following activation connecting a screen assembly to a shale shaker;

Figure 4 is a side view in cross-section of a fastener system releasably connecting a screen assembly according to the present invention to a shale shaker;

25 Figure 5 is a perspective view of a shale shaker;

Figure 6 is a schematic view of a prior art system for processing drilling mud including a shale shaker;

Figures 7 to 9 are perspective views of shale shakers in accordance with the present invention;

30 Figure 10A is a schematic view of a system in accordance with the present invention;

Figure 10B shows a shale shaker of the system of Figure 10A;

35 Figures 11, 12 and 15 are top plan views of screen assemblies in accordance with the present invention, with

- 9 -

parts of layers of screening material cut-away.

Figure 13 is a top plan view of a frame in accordance with the present invention;

Figure 14A is a top view of a plastic grid in accordance with the present invention;

Figure 14B is a perspective view of a plastic grid in accordance with the present invention;

Figure 16 is a cross-sectional view of a screen assembly in accordance with the present invention; and

Figure 17 is a perspective view of a frame support for a screen assembly in accordance with the present invention.

Figures 1A and 1B show a screen assembly 10 in accordance with the present invention which has a perforated plate 11 on which is mounted three layers 12 of mesh or screening material. One, two, four, or more layers of screening material may be used. The plate 11 has a plurality of side holes 18 on each of two of its sides for receiving releasable fasteners for mounting the screen 10 in a suitable shale shaker. Optionally, the screen assembly's plate 11 may also have inner portions 15 with holes 16 therethrough and/or inner portions 15a with interior holes 16a therethrough which holes are also for receiving releasable fasteners for releasably connecting the screen assembly to the shale shaker. To insert the fasteners through the holes 16, 16a and 18 into holes in a deck or bed below a screen assembly, corresponding and appropriate holes or openings are made in the screening material. Although the entire inner portions 15a are revealed in Figure 1A, in an actual screen assembly, prior to making holes in screening material, the holes 16a and inner portions 15a are covered by screening material.

Figure 2A shows a fastener system 20 in accordance with the present invention which has a top member 21 with

- 10 -

a lower portion 22 that is received within a bottom member 23 which has a plurality of spaced-apart fingers 24. The lower portion 22 upon insertion into the bottom member 23 forces the fingers 24 apart for a tight friction fit of the lower portion 22 within the bottom member 23. An upper shoulder 25 of the bottom member 23 abuts the top surface of a screen assembly SC which may be any screen assembly in accordance with the present invention. A shale shaker deck 26 has a hole 27 corresponding to a hole 27a through the screen assembly SC through which is mounted the bottom member 23. Any fastener hole in any screen assembly or part thereof in accordance with the present invention and/or any corresponding hole through a shaker deck in accordance with the present invention may have any desired opening shape as viewed from above, including, but not limited to, rectangular, triangular, elliptical, oval, pentagonal, circular, and hexagonal.

Figure 2B shows the fastener system 20 releaseably holding the screen assembly SC to the shaker deck 26. Spaced apart shoulders 28 and 29 of the top member 21 provide an abutment against the screen assembly SC (the bottom shoulder 28) and a structure (the top shoulder 29) to grasp or contact to facilitate removal of the fastener.

Figures 3A and 3B show another embodiment of a fastener system in accordance with the present invention for releasably connecting a screen assembly to a shale shaker. A system 30 has a fastener 31 with a body 32 and a lower inflatable member 33. A stop shoulder 39 on the body 32 abuts the top of a screen assembly SC (like that of Figure 2A). Following insertion of the body 32 through a hole 34 in the screen assembly SC (see Figure 3A), the inflatable member 33 is inflated through valve apparatus 35 to hold the fastener (and thus the screen

- 11 -

assembly) in place. To release the fastener, the valve apparatus is activated to allow air to escape from the inflated inflatable member 33. The inflatable member 33 is sized and positioned so that, upon inflation, it abuts
5 an underside of the deck 36 (like the deck 26, Figure 2A) of a shale shaker.

Figure 4 shows a fastener 40 for releasably connecting a screen assembly SC (like that of Figure 2A) to a shale shaker with a deck 46 (like the deck 26,
10 Figure 2A). The fastener 40 has a body 41 that is inserted through a hole 42 in the screen assembly SC. Optional threads 43 on the fastener body 41 mate with corresponding threads 44 on the deck 46 to releasably hold the fastener, and thus the screen assembly, in place.
15 Any fastener in accordance with the present invention and any deck in accordance with the present invention may have such threads. Optionally, the threads are deleted and the fastener is held in place with a friction fit; and/or, glue, epoxy, or an adhesive is used to hold the
20 fastener in position (as may be done, optionally, with any other fastener disclosed herein); or a non-threaded locking fastener is used with required holes and/or surfaces on the shaker deck or bed. Any suitable screw or bolt may be used for the body 41. Optionally, the
25 fastener 40 has a top head 45 that facilitates turning of and removal of the fastener 40. Any fastener in Figures 2A - 4 may be used with any screen assembly disclosed herein.

It is within the scope of this invention for the
30 screen assembly SC to have one, two, three or more layers of screening material, i.e., screen, mesh, and/or cloth made, e.g., of stainless steel wire and/or plastic. Any such layer or combination of layers may be bonded together (glued, welded, and/or sintered) in any known
35 manner and/or bonded to the plate 11 in any known manner.

- 12 -

Any such layer or layers of screening material may be substantially flat or may be undulating (with a series of alternating ridges and valleys) as is well known in the art. In accordance with the present invention any known support, plate, strip support, or frame for supporting a shale shaker screen and/or for mounting thereto of one or more layers of screening material, mesh, and/or cloth may have one or more holes for receiving one or more fasteners in accordance with the present invention for releasably connecting a screen assembly to a shale shaker.

Figure 7 shows a shale shaker 70 in accordance with the present invention which is like a shaker disclosed in U.S. Patent 5,641,070 co-owned with the present invention; but the shaker 70 has a basket 71 with screen mounting decks 72 and 73. Supports 72a and 73a of the decks 72 and 73, respectively, have holes 72b, 72c, 72d and 72e therethrough (in deck 72) and 73a, 73b, 73c (in deck 73). As desired such holes may be provided on all sides and/or on all cross-members of either or both decks. These holes are sized and positioned to correspond to holes in a screen support (and, optionally, holes through screening mesh and/or cloth) of screen assemblies (not shown) to be mounted in the basket 71. Springs 75 (two shown; four, six or more may be used) support the basket in a shaker body 76 and one or more vibrators 77 connected to the basket 71 vibrate the basket 71. Holes as in either or both decks 72, 73 may be provided for the deck(s) of any known multi-deck shale shaker so that screen assemblies in accordance with the present invention with holes in accordance with the present invention may be releasably fastened thereto.

Figure 8 shows a shale shaker 80 in accordance with the present invention with screen assemblies 81, 82 in accordance with the present invention mounted in a basket

- 13 -

83 to decks 86, 87 with fasteners 84, 85 which may be any screen assembly disclosed herein in accordance with the present invention. The fasteners 84, 85 extend through holes (not shown) in the screen assemblies into holes (not shown) in the decks 86, 87. The basket 83 is mounted on spring mounts 88 (three shown; four used in this embodiment) and is vibrated by a vibrator 89.

Referring now to Figure 9, a shale shaker 90 in accordance with the present invention has a screen deck 92 in accordance with the present invention in a basket 91. The deck 92 has holes 93 therearound into which are releasably inserted fasteners (not shown; including, but not limited to, fasteners as disclosed herein and/or fasteners in accordance with the present invention) to releasably secure one or more screen assemblies (not shown) to the deck 92. Any screen in accordance with the present invention may be used on the deck 92. The basket 91 is mounted on springs 94 (only two shown; two as shown are on the opposite side) which are supported from a frame 96. The basket 91 is vibrated by a motor 99 and interconnected vibrating apparatus 98 which is mounted on the basket 91 for vibrating the basket and the screens. Optional elevator apparatus 97 provides for raising and lowering of the basket end.

Referring now to Figures 10A and 10B a well 111 is being drilled by a bit 112 carried on a string of drill pipe 114. Drilling mud is pumped by a pump 118 into the drill pipe 114 and out through nozzles in the bit 112. The mud cools and cleans the cutters of the bit and then passes up through a well annulus 116 flushing cuttings out with it.

After the mud is removed from the well annulus 116, it is treated before being pumped back into the pipe 114. First, the mud enters the shale shaker 110 where relatively large cuttings are removed. The mud then

- 14 -

enters a degasser 124 where gas can be removed if necessary. Degasser 124 may be automatically turned on and off, as needed, in response to an electric or other suitable signal produced by a computer 124 and communicated to degasser 124 as indicated by line 125. The computer 1344 produces the signal as a function of data from a sensor assembly 136 associated with shale shaker 110 and described more fully below. The data from sensor assembly 136 is communicated to computer 134 by line 182. The mud then passes to a desander and (or a desilter), jointly represented by station 126, for removal of smaller solids picked up in the well.

The mud next passes to a treating station 128 where, if necessary, conditioning media, such as barite, may be added from source 130. As shown, suitable flow control means, indicated in a simplified form by valve 132, controls flow of media from source 130 to station 128. Valve 132, in turn, may be automatically operated by an electric or other suitable signal produced by computer 134 as a function of the data from sensor assembly 136, such signal being communicated to valve 132 as indicated by line 131.

From the station 128, the mud is directed to tank 140, from which pump 118 takes suction, to be re-cycled through the well. Any shale shaker disclosed herein may be substituted for the shale shaker 110. The system 100 is like the systems disclosed in U.S. Patent 5,190,645, but the system 100 has a shale shaker in accordance with the present invention.

The shale shaker 110 as shown in detail in Figure 10B has a basket 121 in which a screen mounting deck 122 (shown schematically in Figure 10B). A screen assembly 123 in accordance with the present invention (shown schematically) is releasably secured to the deck 122 by a plurality of spaced-apart fasteners 133 which extend

- 15 -

through holes 135 in the screen assembly 123 and through corresponding holes 137 in the deck 122. Vibrator apparatus 139 vibrates the basket 121 which is mounted on mounts 127. Material flows through exit structure 141
5 into a collection receptacle 143.

The screen assembly 123 may be any (one, two, three or more) screen assembly in accordance with the present invention and the fasteners 133 may be any fastener in accordance with the present invention.

10 Figure 11 shows a screen assembly 190 in accordance with the present invention which has a lower tubular frame support 191 to which is connected and/or welded a perforated plate 192 (including, but not limited to a perforated plate like that disclosed in U.S. Patent
15 4,575,421; but with holes in accordance with the present invention for receiving fasteners in accordance with the present invention to releasably connect the screen assembly 190 to a shale shaker).

Referring to Figure 11, the perforated plate 191 of
20 the screen assembly 190 has a plurality of peripheral holes 193 and a plurality of interior holes 194 (either holes 193 or holes 194 may be deleted - as is the case for any support, plate, or frame in accordance with the present invention). A plurality of fasteners 195 (two
25 shown; one through each hole 193, 194) connect the plate 192 to the tubular frame support 191. The fasteners' lower ends are received in holes 196 of the tubular frame support 191 whose position corresponds to that of the holes 193, 194.

30 As shown in Figure 11 there are three layers 197a, 197b, 197c of screening material on the plate 192. Any one or two of these layers may be deleted; any known combination of layers may be used; and the layers may or may not be connected and/or bonded together at their
35 edges and/or across their surfaces in any known manner

- 16 -

with any known material and/or process. Any known suitable tubular members may be used to make the tubular frame support 191 with its outer members 191a and its cross-members 191b.

5 Figure 12 shows a screen assembly 210 in accordance with the present invention with a UNIBODY structure 220 in accordance with the present invention. The screen assembly 210 has, optionally, three 211, 212, 213 of screening material (shown partially; extending over the
10 entire open area of the UNIBODY structure 220) bonded to a top surface 222 of the UNIBODY structure 220. Preferably, the layers 211, 212, 213 are also bonded together over substantially their entire surface area. A plurality of fasteners 240 extend through holes 241 in
15 the UNIBODY structure 220 to releasably connect the screen assembly 210 to a screen mounting deck 242 of a shale shaker (not shown in its entirety). Optionally, one or more fasteners 243 (one shown) may extend through the layers of screening material on the screen assembly
20 210 and into the deck 242.

 A plurality of openings 224 through the UNIBODY structure 220 define a plurality of support members 226. To the underside of the UNIBODY structure 220 are, optionally, connected a plurality of spaced-apart ribs
25 228 which, in one aspect are welded to a metal UNIBODY structure 220. In this particular embodiment the ribs 228 are positioned along a substantial majority of their length directly beneath one of the support members 226 that extend across a major portion of the UNIBODY
30 structure 220; but it is within the scope of this invention to use no such ribs or to position them anywhere on the underside of the UNIBODY structure 220. The UNIBODY structure 220 has spaced-apart sides 236, 238. The screen assembly 210 has an end 214 and a ledge
35 end 216. The ledge end has an upper ledge portion that

- 17 -

rests on a shoulder of an end of an adjacent screen. Thus one screen end seals against another screen end when such screens are used end-to-end (as described in U.S. Patent 6,283, 302 co-owned with the present invention).

5 Figure 13 shows a screen strip support 250, in accordance with the present invention with a plurality of spaced-apart strips 252 (made of any suitable metal or metal-like material) secured to and between spaced-apart sides 254. The screen strip support 250 is like the
10 strip support of Figure 51A, U.S. Patent 6,290,068 (co-owned with the present invention); but the screen strip support 250 has outer holes 267 and inner holes 268 through which may be inserted any fastener disclosed herein for releasably connecting the support 250 (and any
15 screen assembly of which it is a part) to a shale shaker deck. Either holes 267 or holes 268 may be deleted. Any known strip support may be provided, in accordance with the present invention, with holes 267 and/or holes 268. Each end 256 of each strip 252 is received and held in a
20 recess 264 in a side 254. The recess 264 corresponds in shape to the shape of the end 256 and a shoulder 266 of each strip 252 abuts a side 254. The end 256 may be inserted into the recess 254 from the side or from above or below. The top and bottom strips 252 each has two
25 humps or ridges 253 which are located, sized, and configured to be received in corresponding corrugations of a corrugated plate and/or corrugated screen assembly. It is within the scope of this invention for each strip to have one, two, or a plurality of multiple humps or
30 ridges. In one aspect there is one hump or ridge for each corrugation on a superimposed plate and/or screen assembly. It is within the scope of this invention to delete the humps and/or ridges so that the strips 252 are flat for use with flat mesh and/or screen(s).

35 Figures 14A and 14B show plastic grids 270, 271,

- 18 -

respectively, each with a body 270d, 271d respectively
with a plurality of openings 270a, 270b, 271b
respectively, therethrough. Although only certain of the
openings 271b are shown, it is to be understood they
5 extend across the entire surface of the body 271d. The
plastic grids 270, 271 are like plastic grids disclosed
in U.S. Patents 5,417,859; 5,958,236; 5,783,077; and
6,053,332; but the grids 270, 271 each have a plurality
of spaced-apart holes 270c, 271c, respectively
10 therethrough for accommodating fasteners in accordance
with the present invention which extend through a screen
assembly in accordance with the present invention to
releasably connect a screen assembly to a shale shaker.
Any grid disclosed in the patents cited above and any
15 known plastic grid or piece used in a screen assembly for
a shale shaker may have holes as shown in Figures 14A and
14B (and/or any holes disclosed herein for any perforated
plate or support disclosed herein); and any screen or
screen assembly disclosed in the patents cited above may
20 have any such grid or piece. Any such grid or piece in
accordance with the present invention may have holes
corresponding to any fastener holes as described herein.
In one aspect the holes in the grid or piece are made, in
accordance with the present invention, prior to the final
25 formation or assembly of a screen or screen assembly (as
may also be the case with any perforated plate or strip
support in accordance with the present invention); while
in another aspect the holes are made through the plastic
grid (and/or through other parts, pieces and/or layers of
30 the screen or screen assembly) following final formation
or assembly thereof (as may also be the case with any
perforated plate, frame or strip support in accordance
with the present invention). It is to be understood that
it is within the scope of the present invention to have a
35 plastic layer or a mass of fusing plastic fusing together

- 19 -

layers of screening material, the layer or mass optionally provided initially by a plastic grid, the plastic layer or mass having holes for fasteners corresponding to holes in a screening material support.

5 Figure 15 shows a screen assembly 280 in accordance with the present invention with a lower supporting perforated plate 281 in accordance with the present invention. The screen assembly 280 is like those disclosed, e.g., in U.S. Patent 4,575,421; but without
10 hookstrip mounting apparatus and with a plurality of peripheral holes 282 and one or more interior holes 284 for receiving fasteners 283 to releasably connect the screen assembly 280 to a shale shaker (not shown) whose deck or mounting structure has corresponding holes for
15 releasably receiving a portion of the fasteners 283 (as is the case for a shale shaker and fasteners through any screen or screen assembly in accordance with the present invention). In certain preferred aspects holes 282 and/or 284 are simply added to a perforated plate as
20 shown in U.S. Patent 4,575,421; while in other aspects the plate is initially made so that plate portions 288 have only a hole 282 or a hole 284. In one particular aspect (as is true for any perforated plate in accordance with the present invention) an area like the areas 288
25 (and/or like the areas 15, Figure 1A and/or like the areas around the holes 193, 194, Figure 11 and for any plastic grid or piece in accordance with the present invention) are at least as large (viewed from above) as one of the openings or perforations through the plate and
30 in another preferred aspect are at least twice as large (viewed from above) as such an opening or perforation.

One, two, or three (or more) layers of mesh and/or screening material may, in accordance with the present invention, be used on a perforated plate 280 (or on any
35 perforated plate in accordance with the present

- 20 -

invention); e.g., as shown in Figure 15, three layers 285, 286, and 287 are used on the plate 281. Although these layers are shown partially, it is to be understood they substantially cover the plate 281.

5 The prior art discloses a variety of non-flat screens and screen assemblies sometimes referred to as "3D" or "Three Dimensional" screens (e.g., but not limited to, as disclosed in U.S. Patents 5,417,793; 5,417,858; 5,417,859; 6,053,332; 5,598,236; 5,783,077; 10 6,283,302; 6,290,068). Figure 16 illustrates that, in accordance with the present invention, non-flat screen assemblies may be fastened with releasable fasteners passing through holes therethrough to a shale shaker. A screen assembly 290 (shown partially) has a lower 15 perforated plate 291 (which, optionally, may be any support plate, frame, or strip support) with a plurality of spaced-apart openings 292 therethrough (see, e.g., but not limited to, Figure 13, U.S. Patent 5,417,858; and Figure 3, U.S. Patent 5,417,859 regarding possible plates 20 and screening material). A plurality of fasteners 295 passing through holes 296 (in screening material 294), holes 297 (in the plate 291) and into (and, optionally, through) holes 298 (in a shaker deck 293).

As shown in Figure 16, it is also within the scope 25 of this invention to employ one or more fasteners 299 which extend through a portion of the screening material 294 that is not directly adjacent the plate 291 but which is spaced-apart therefrom. As shown a fastener 299 passes through a highest (with respect to the plate 291 30 as viewed in Figure 16) portion of the screening material 294 and through holes 299a, and 299b, in the plate 291 and deck 293, respectively, and through a hole 299c in the material 294; but it is within the scope of this invention to have one or more fasteners 299 (or 295) pass 35 through any part or portion of the screening material

- 21 -

294. As may be the case with any fastener in accordance with the present invention and any fastener used with a screen assembly in accordance with the present invention, any suitable desired washer(s) and/or sleeve(s) may be used with the fastener(s) 295, 299 at any interface and/or for any hole.

It is within the scope of the present invention to provide holes for fasteners as disclosed herein in any known prior art frame used as a support for screening material for a screen assembly for a shale shaker. Figure 17 illustrates a frame 300 in accordance with the present invention which is like a frame as disclosed in U.S. Patent 5,417,858, Figure 8; but which has a series of outer holes 301 through tubular frame members 302 and, optionally, (or instead of the holes 301) holes 303 through interior tubular members 304. Any holes described herein for releasably fastening a screen assembly to a shale shaker may be used in the frame 300 or in any frame support for a shale shaker screen assembly. Any layer or layers of mesh or screening material described or referred to herein or known in the prior art may be used on the frame 300 or on any frame in accordance with the present invention.

With screen assemblies in accordance with the present invention (e.g. as in Figure 1A) which employ no lower support frame, any opening through the lower support can receive a common plug to replace torn screening material above the opening and no frame member blocks any of the openings which could require a customized plug.

- 22 -

CLAIMS:

1. An apparatus for separating solids from a solids laden drilling mud, said apparatus comprising a shale shaker having a screen deck arranged in a basket, said basket having walls and a screen assembly having two spaced-apart ends spanning between said walls of said basket, said screen assembly comprising a support comprising a perforate plate and at least one layer of screening material tensioned thereon and fixed thereto characterised in that, said screen deck comprises a plurality of holes or recesses and said screen assembly comprises a plurality of corresponding holes in the interior of said screen assembly between said spaced-apart ends, the apparatus further comprising a plurality of fasteners for releaseably connecting said screen assembly to said shale shaker through said plurality of holes of said screen deck and said screen assembly.
2. The apparatus as claimed in claim 1, wherein said support further comprises a series of spaced-apart strips.
3. The apparatus as claimed in claim 1 or 2, wherein said support further comprises an outer frame.
4. The apparatus as claimed in claim 3, further comprising cross-members spanning said outer frame.
5. The apparatus as claimed in any one of claims 1 to 4, wherein said perforate plate has wing portions which are folded to form a support structure.
6. The apparatus as claimed in any one of claims 1 to 5, wherein the screen assembly further comprises a plurality of spaced-apart holes extending through the two spaced-apart ends.
7. The apparatus as claimed in any one of claims 1 to 6, wherein said plurality of holes in said screen assembly pass through said at least one layer of screening material.

- 23 -

8. The apparatus as claimed in claim 7, wherein said at least one layer of screening material comprises a plurality of layers of screening mesh.
9. The apparatus as claimed in any one of claims 1 to 8, wherein said screen assembly comprises flat layers of screening material.
10. The apparatus as claimed in any one of claims 1 to 9, wherein said screen assembly comprises an undulating layer of screening material having undulations with ridges and valleys.
11. The apparatus as claimed in any one of claims 1 to 10, wherein the fasteners are selected from the group consisting of threaded fasteners, bolts, locking fasteners, finger expansion fasteners, air injection fasteners, and friction-fit fasteners.
12. The apparatus as claimed in any one of claims 1 to 11, wherein said fasteners are secured to said screen assembly.
13. The apparatus as claimed in any one of claims 1 to 12, wherein said fasteners are secured to said shale shaker.
14. A screen assembly for use in a shale shaker for separating solids from a solids laden drilling fluid, said screen assembly having two spaced-apart ends comprising a support comprising a perforate plate and at least one layer of screening material tensioned thereon and fixed thereto and wherein said screen assembly comprises a plurality of holes in an interior of said screen assembly between spaced-apart ends which, in use, correspond to a plurality of holes or recesses in a screen deck of a shale shaker for releaseably connecting said screen assembly to said shale shaker with a plurality of fasteners through said plurality of holes.
15. A kit comprising a screen assembly as claimed in claim 14, and a fastener of the apparatus as claimed in any one of claims 1 to 13.

- 24 -

16. A method for replacing a screen assembly in a shale shaker, the shale shaker comprising a basket and a screen deck arranged in the basket, the basket having walls, the screen deck having a plurality of holes or recesses, the screen assembly having two ends spanning between the walls of the basket, the screen assembly comprising a support comprising a perforate plate and at least one layer of screening material tensioned thereon and fixed thereto, the screening assembly having a plurality of corresponding holes in an interior of said screen assembly between the two spaced-apart ends, the method comprising the step of fastening the screen assembly to the screen deck through the plurality of holes with a fastener.

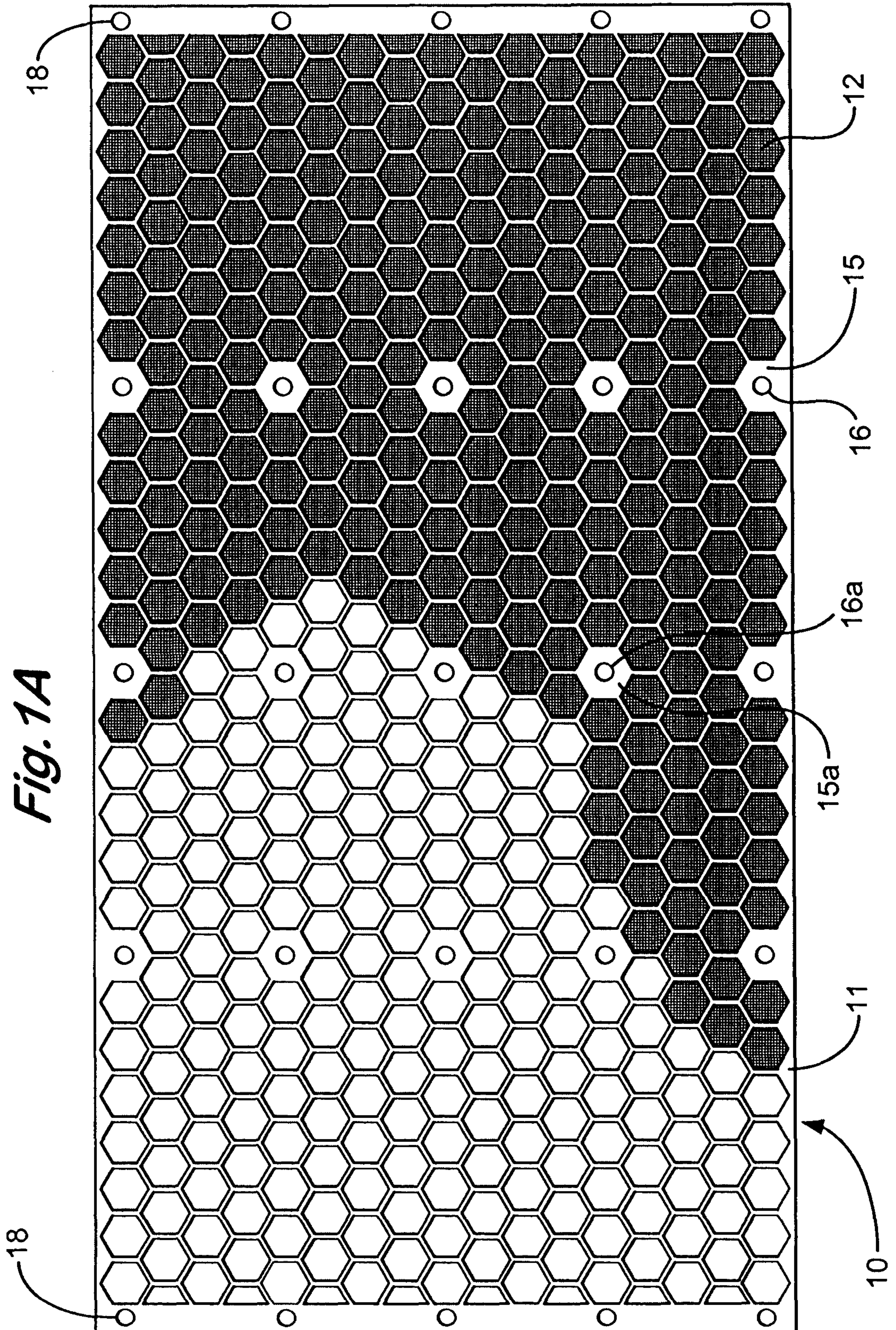

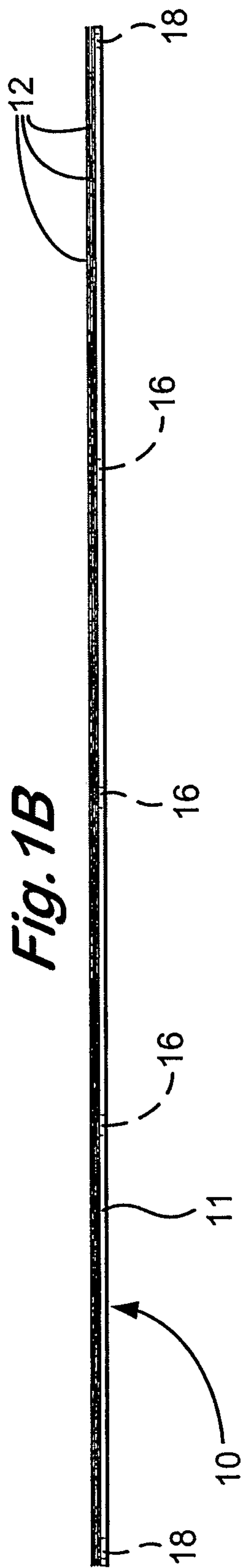

Fig. 1B

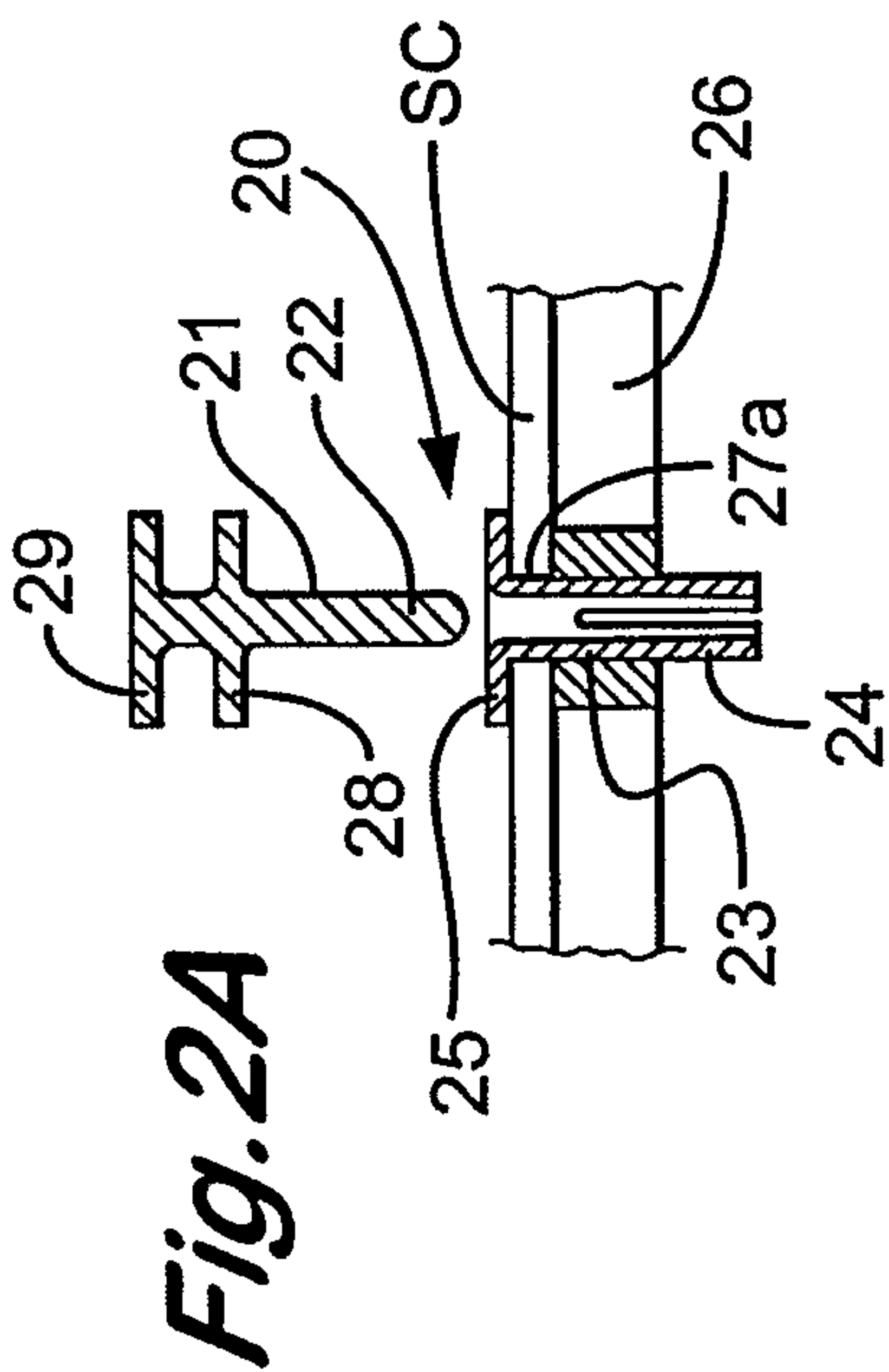

Fig. 2A

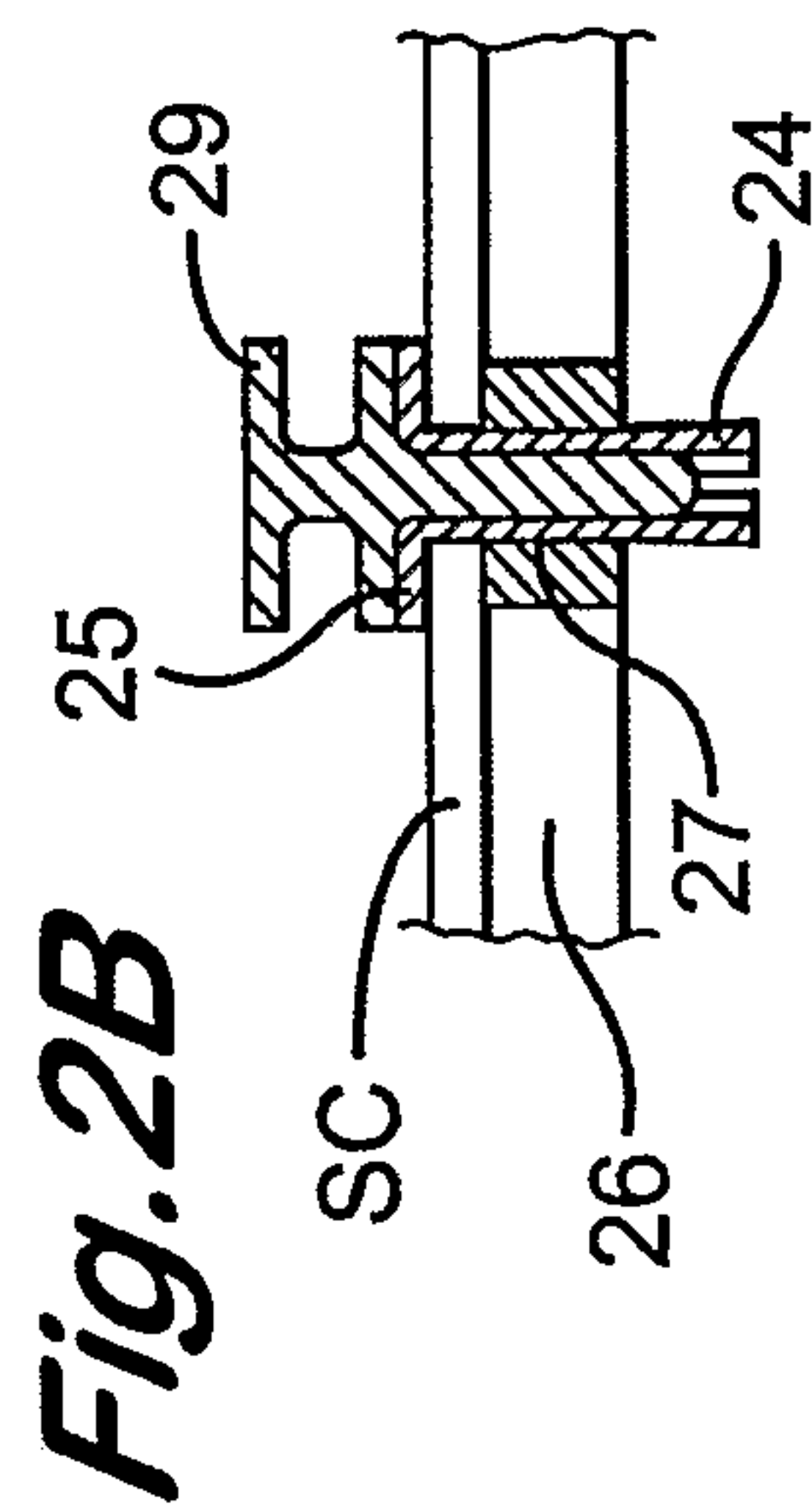

Fig. 2B

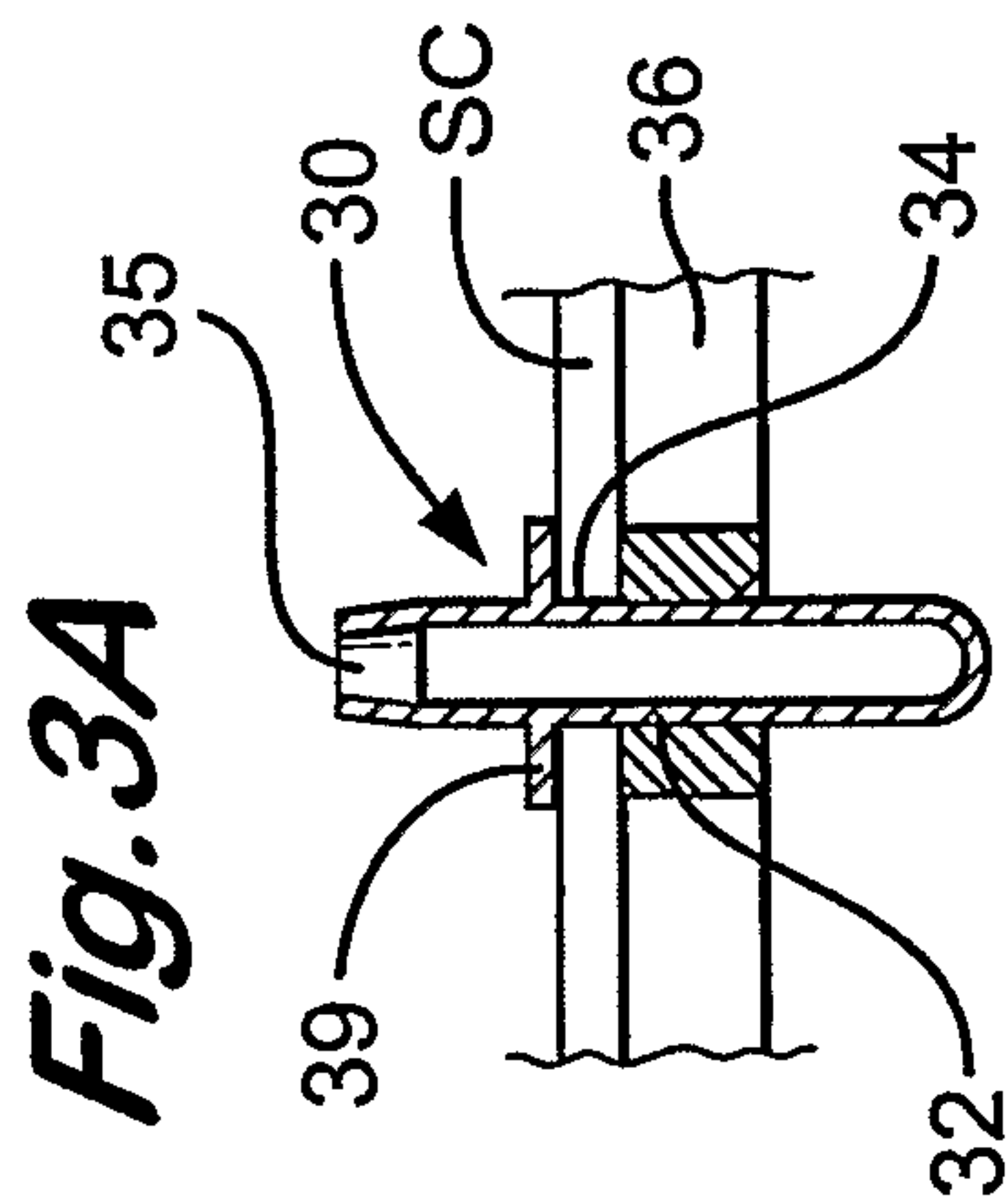

Fig. 3A

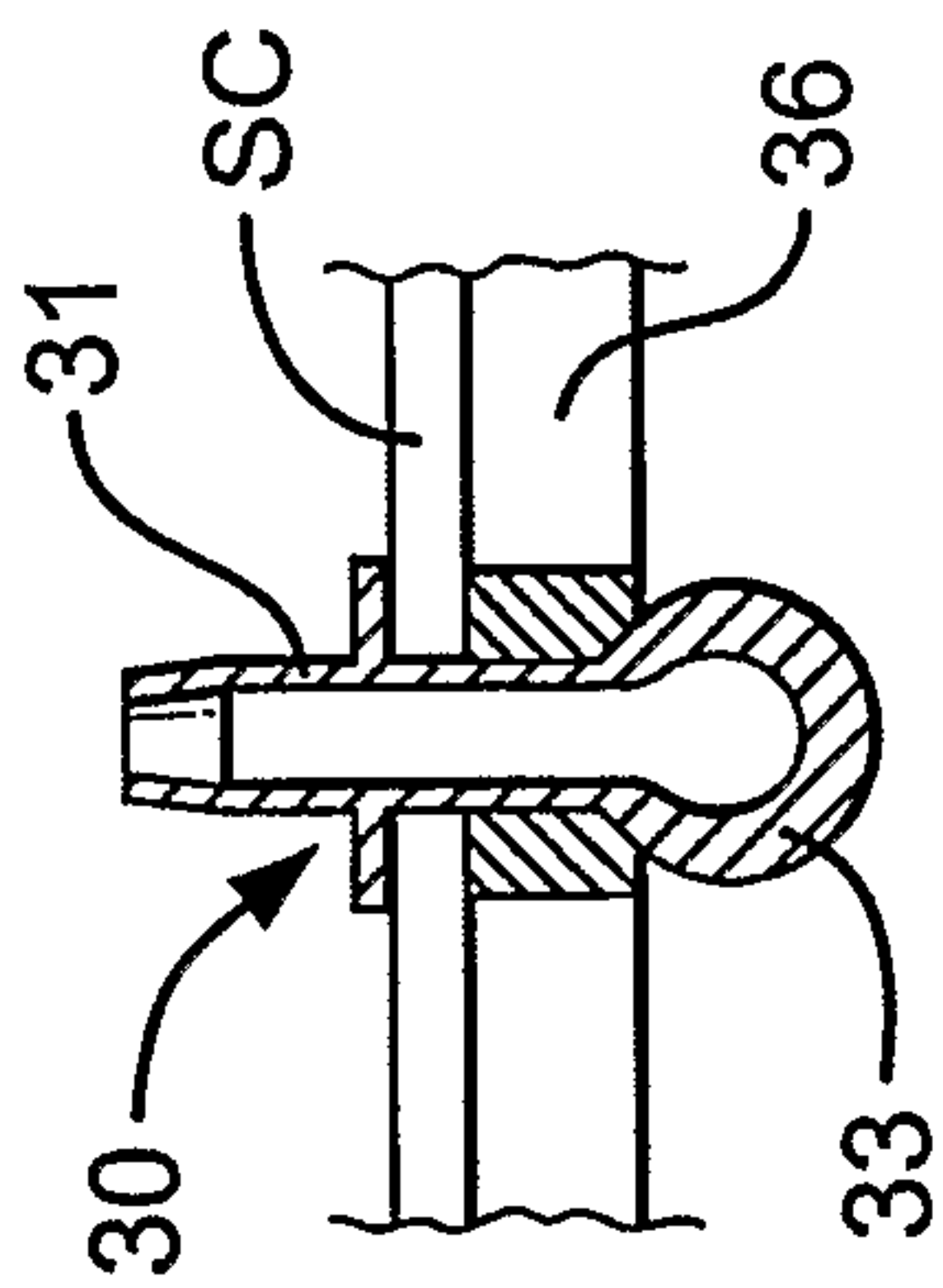

Fig. 3B

2/13

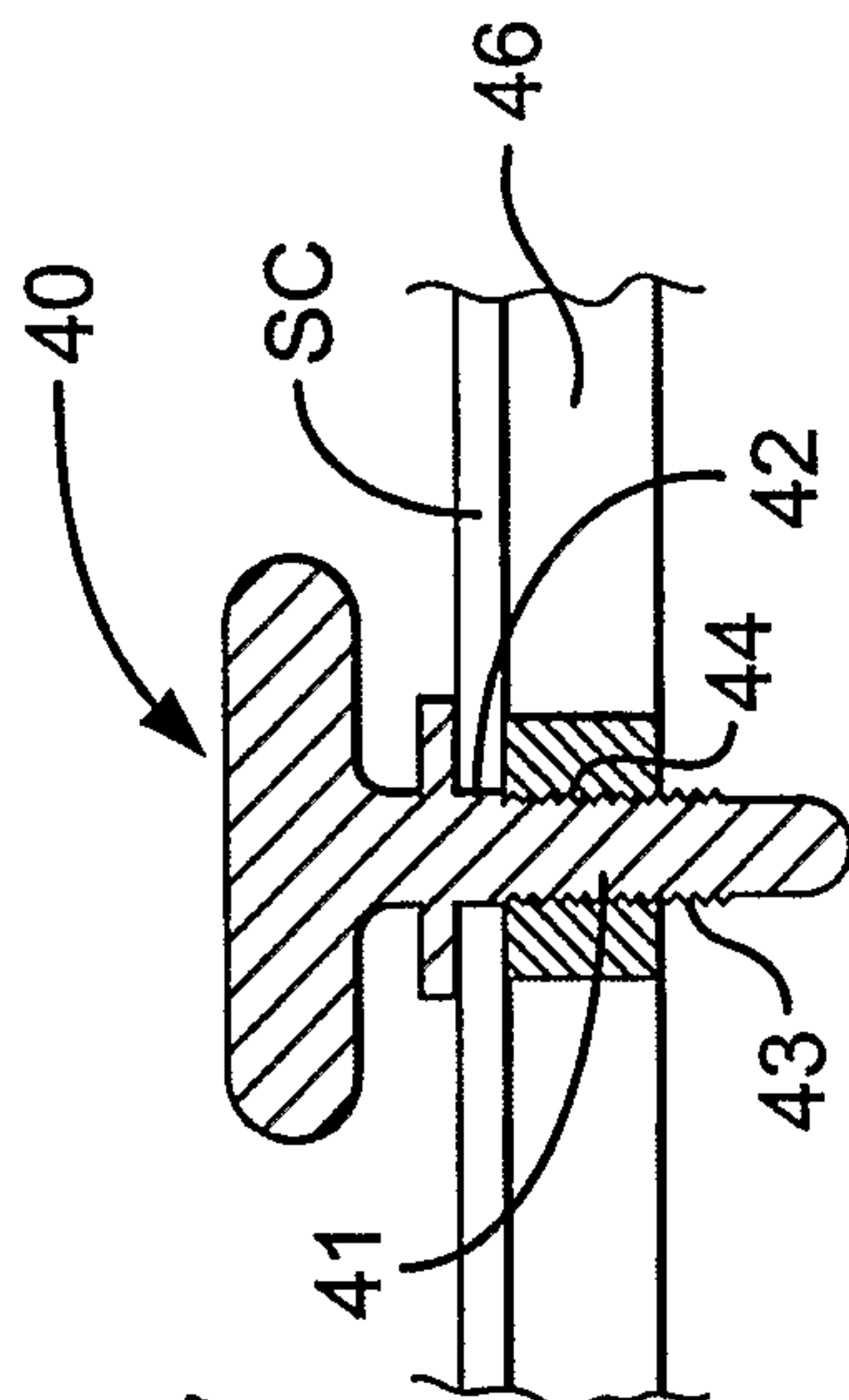

Fig. 4

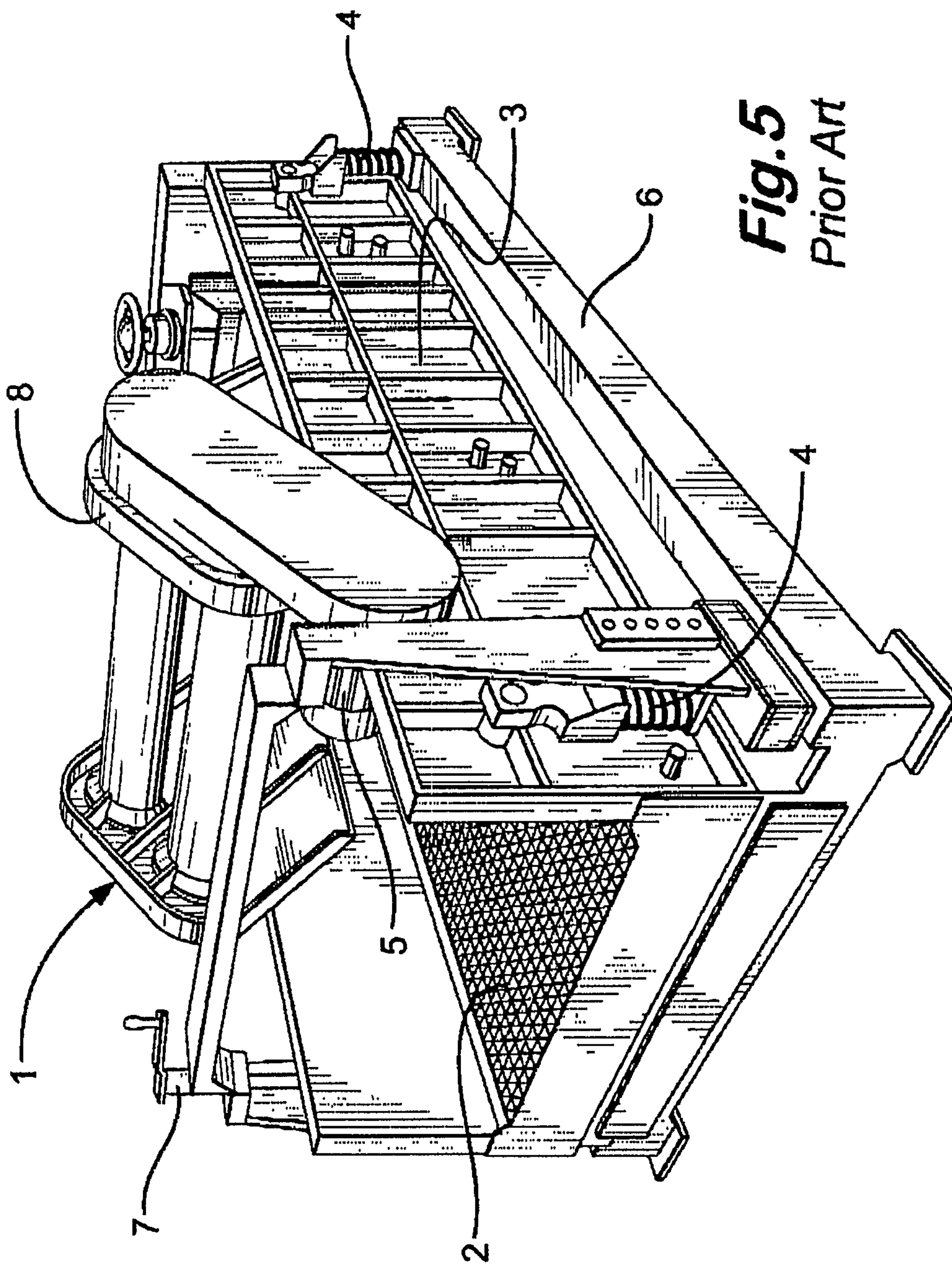
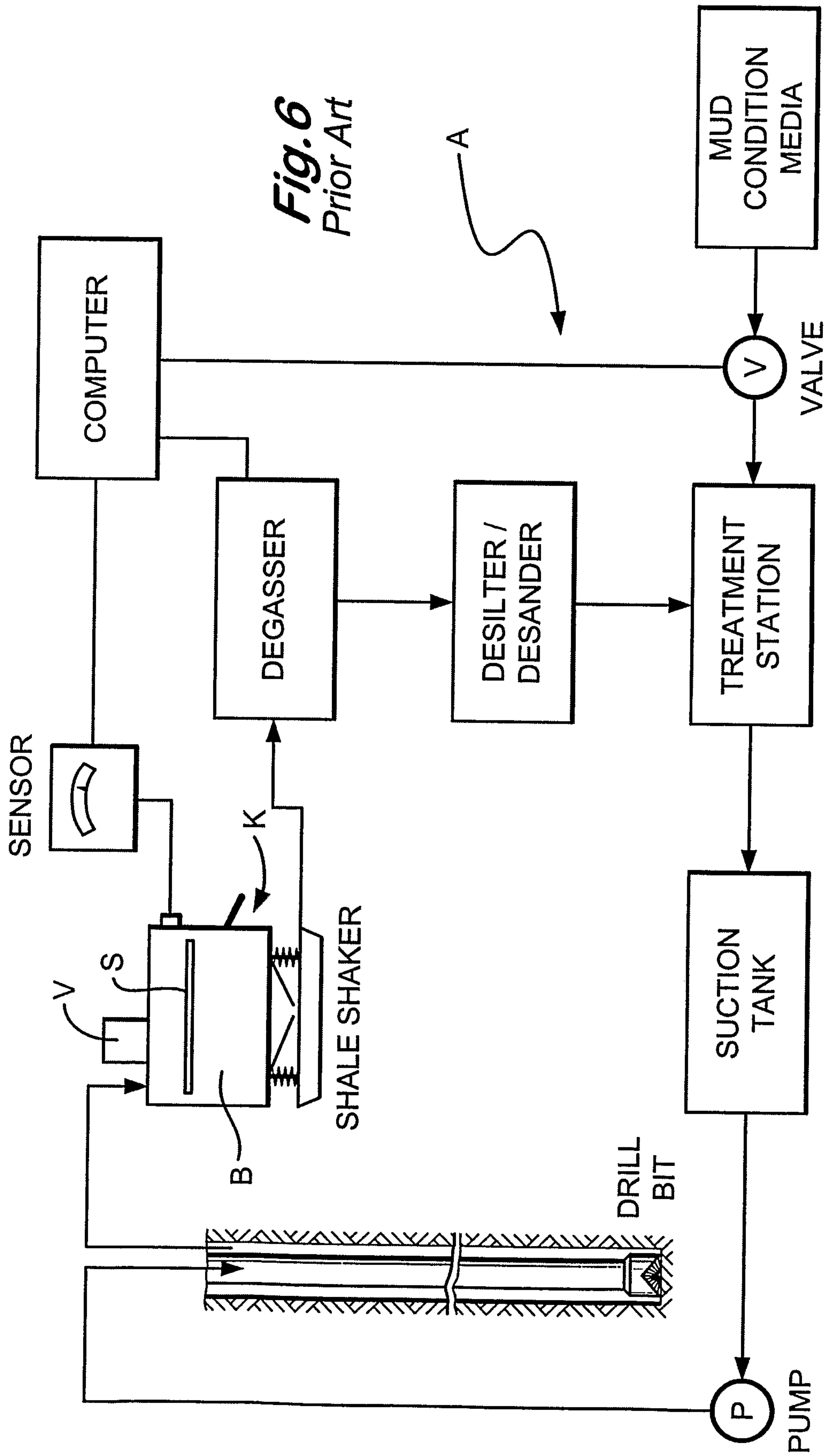

Fig. 5
Prior Art

4/13



5/13

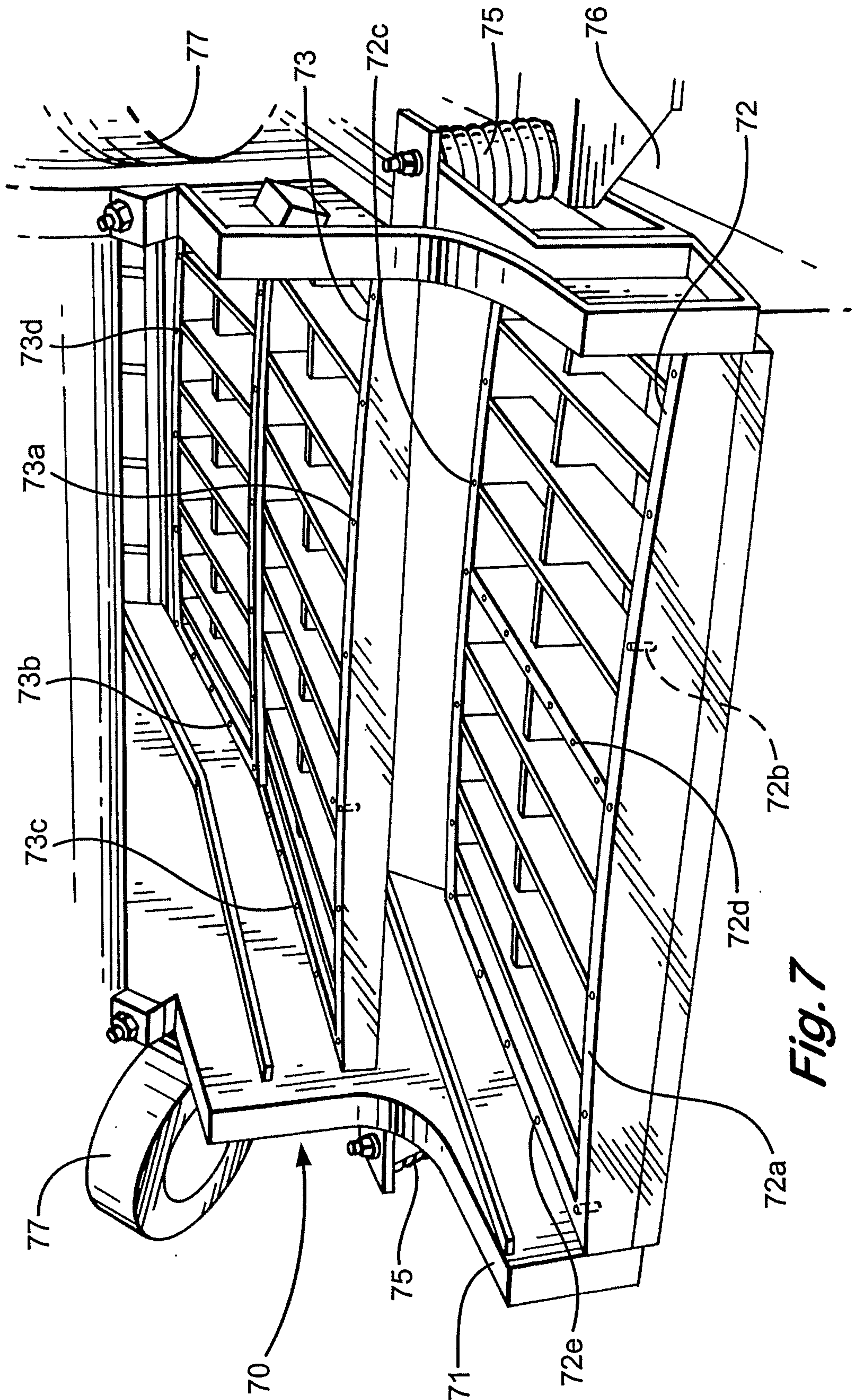

Fig. 7

6/13

Fig. 8

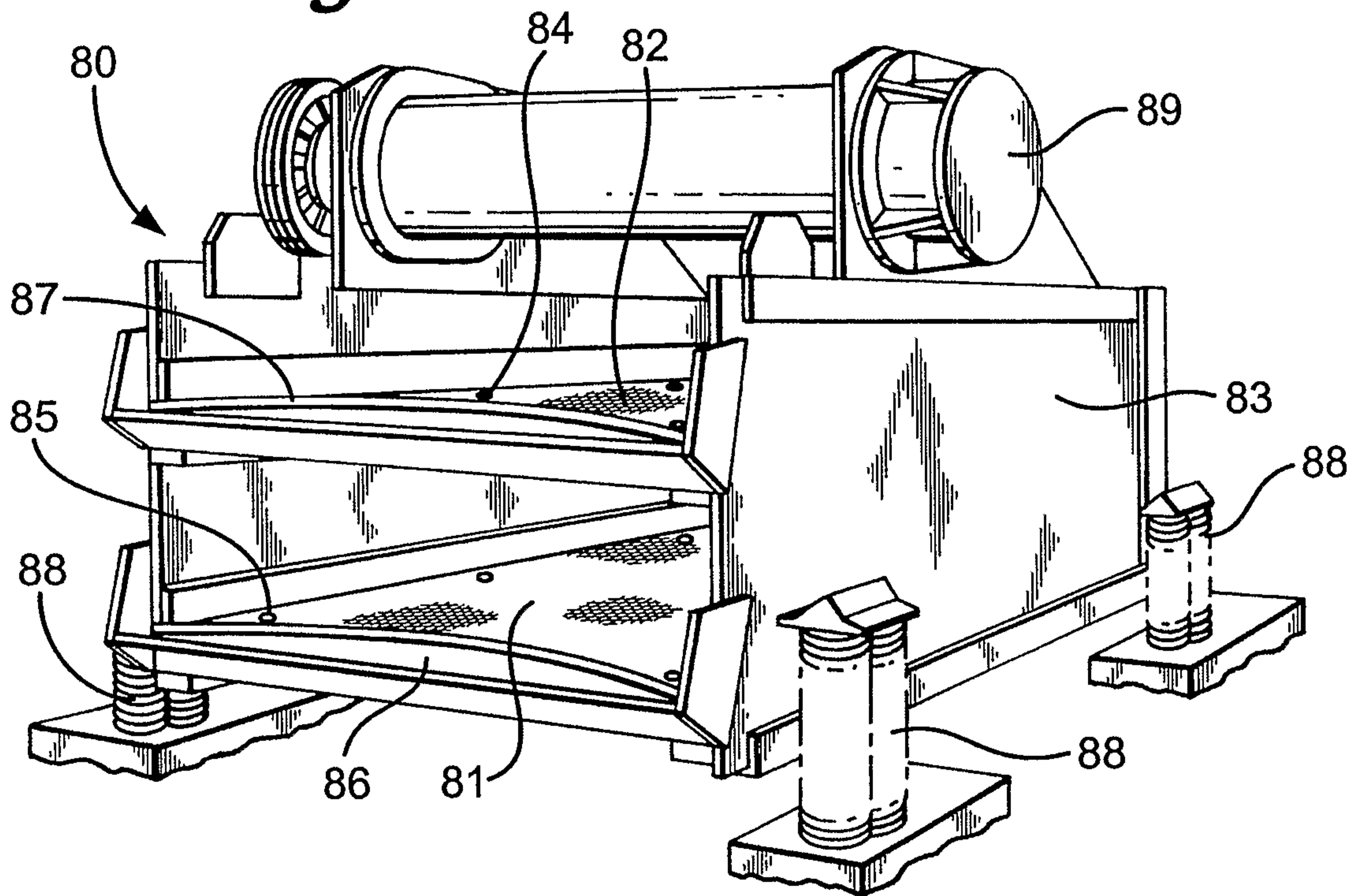
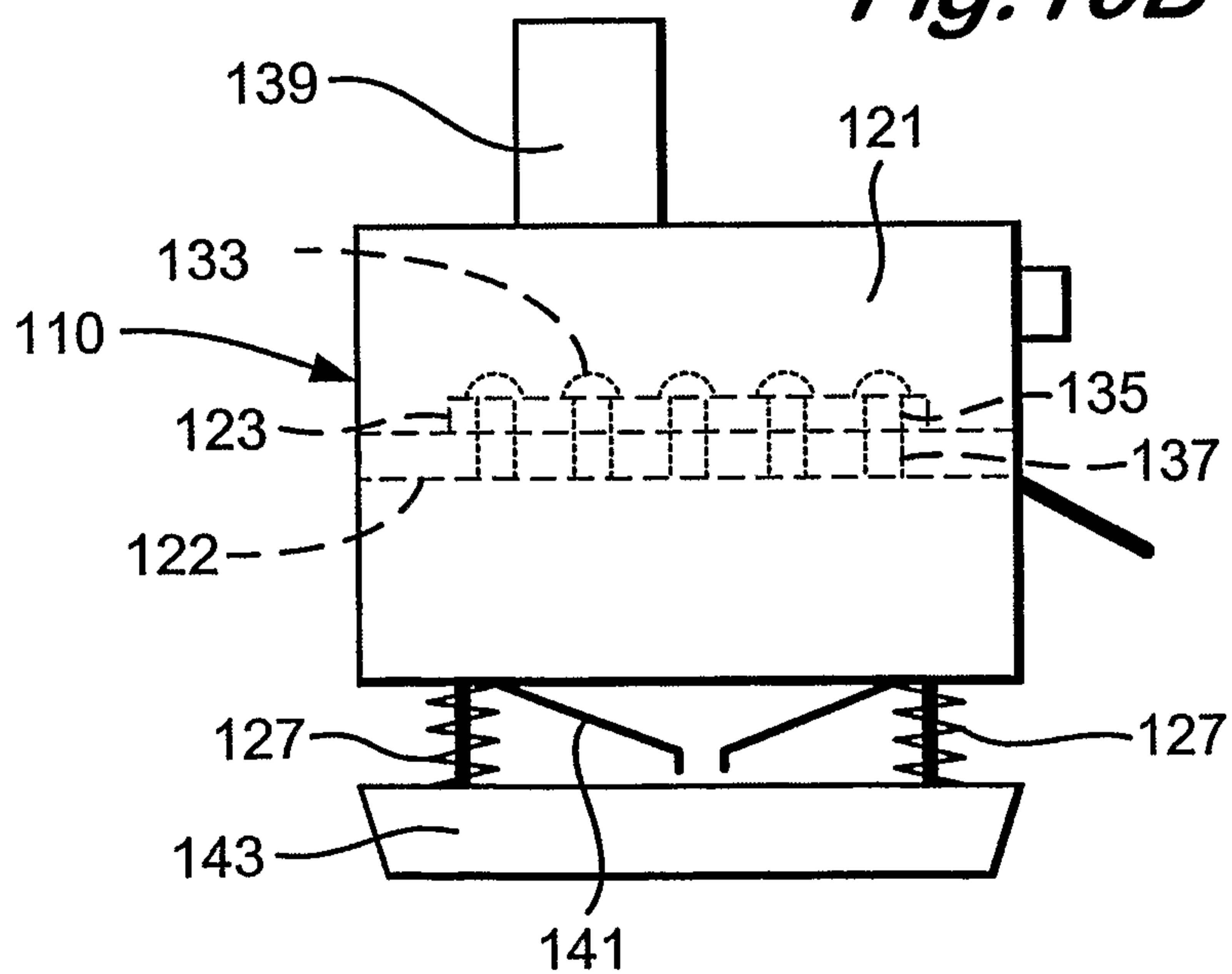
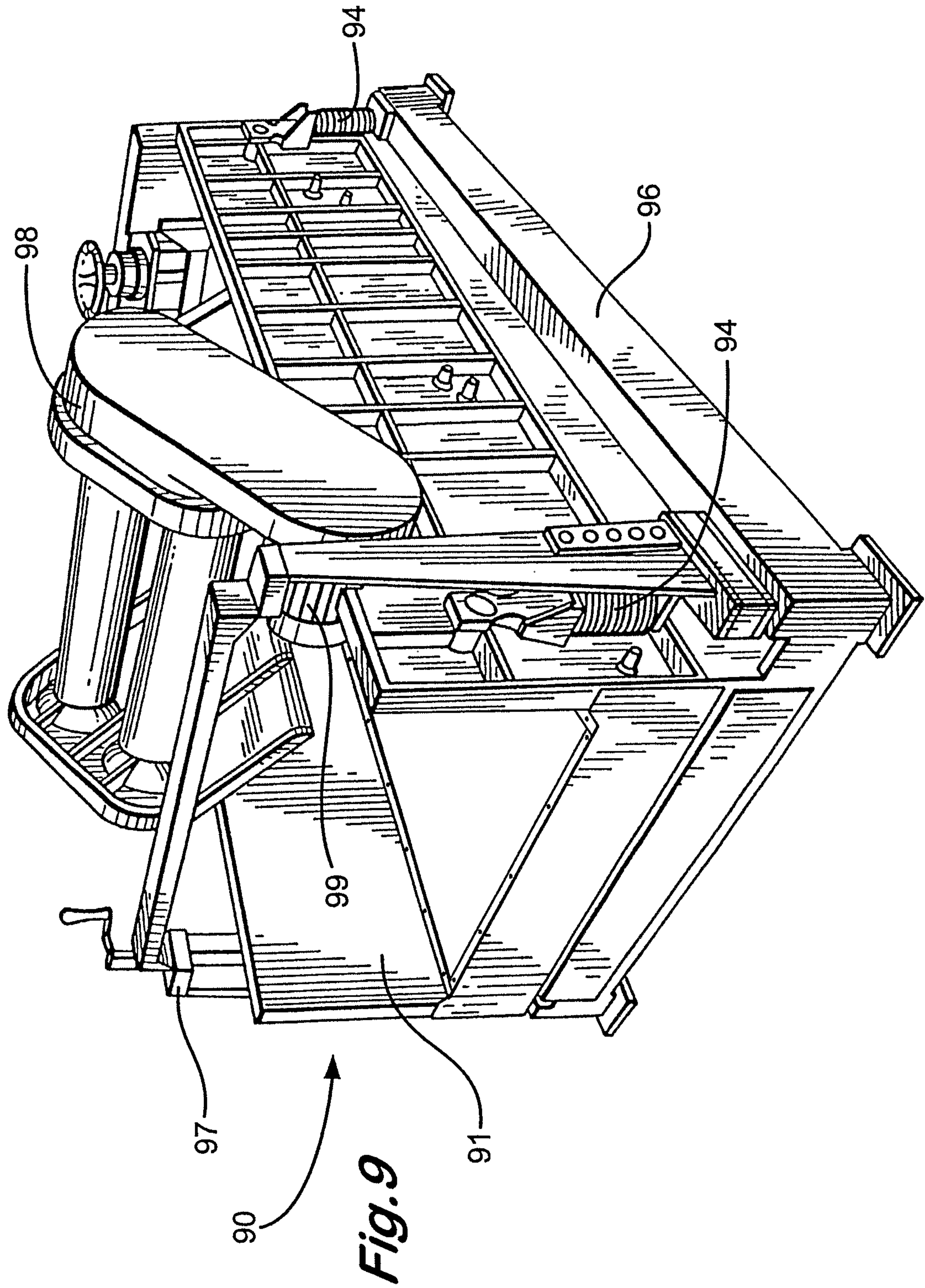

Fig. 10B



7/13



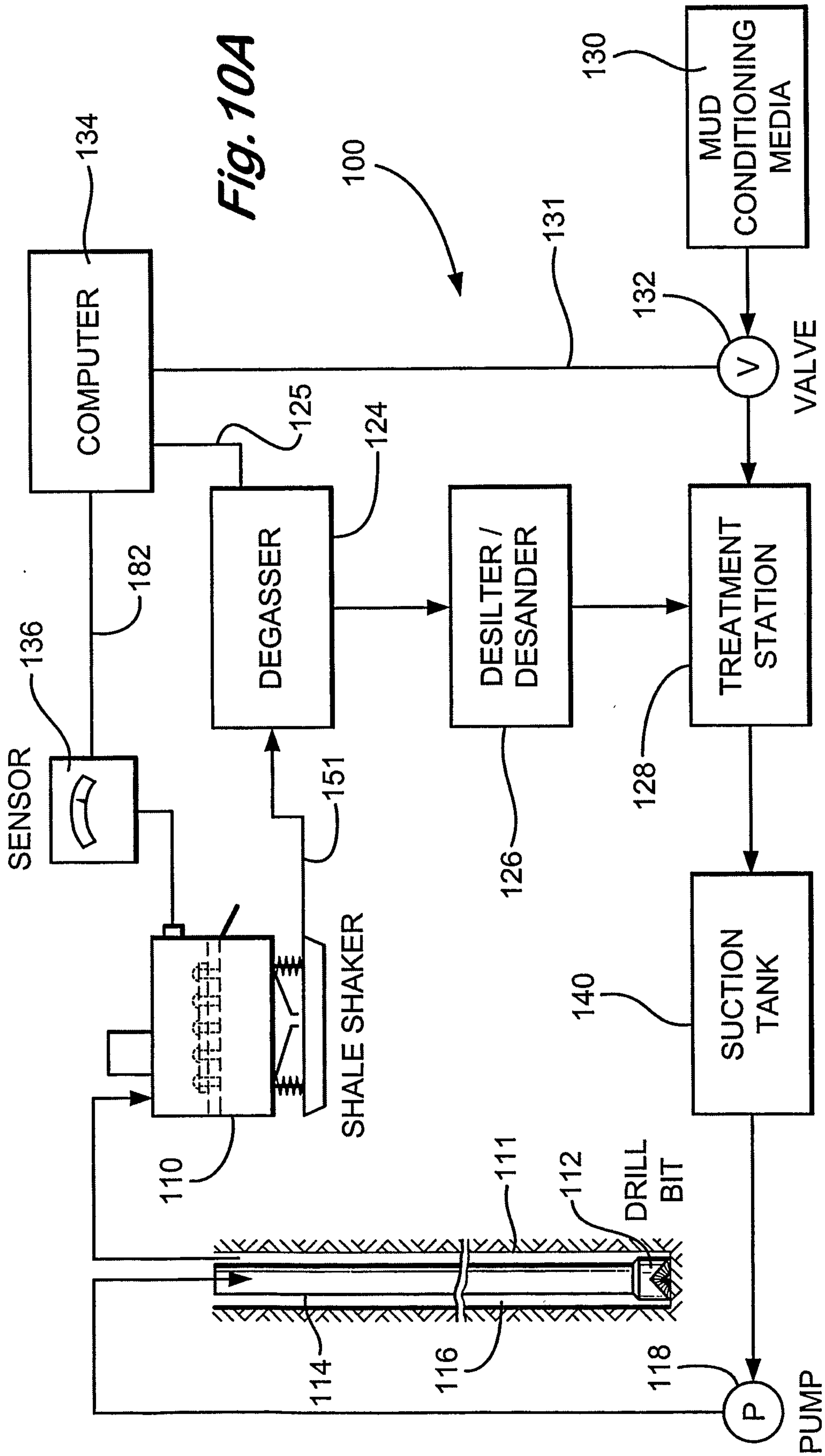
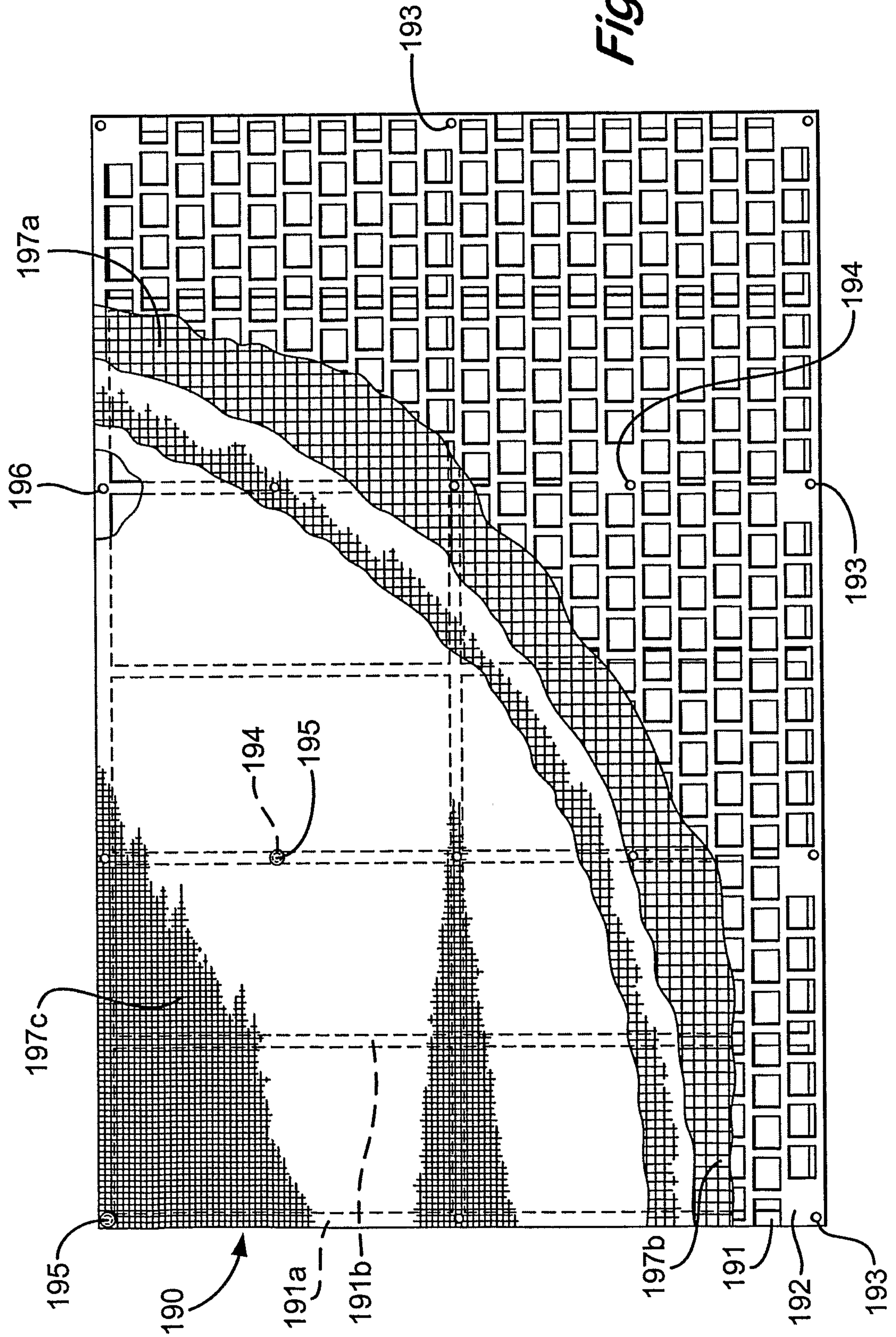
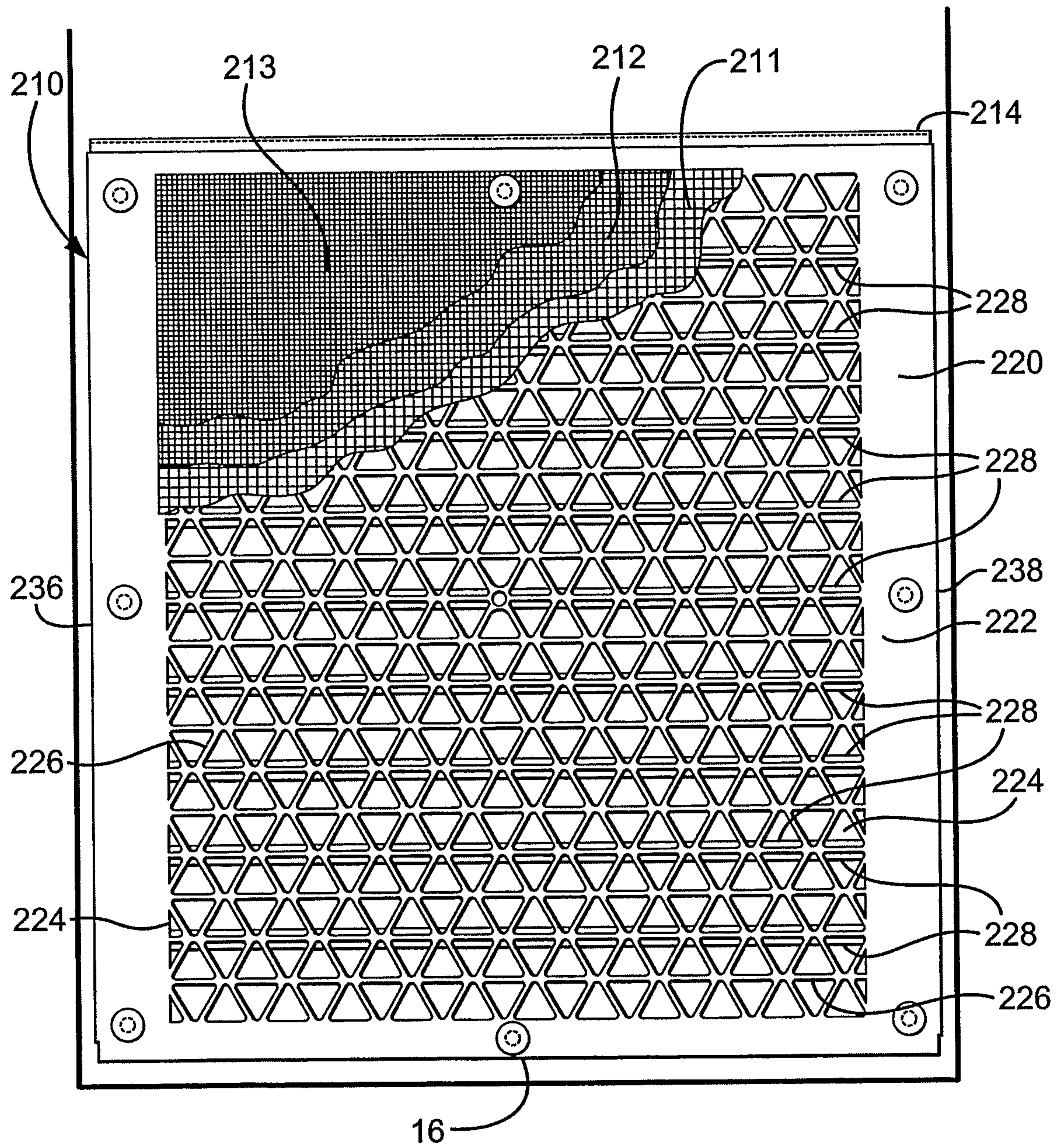

Fig. 11



10/13

Fig. 12



11/13

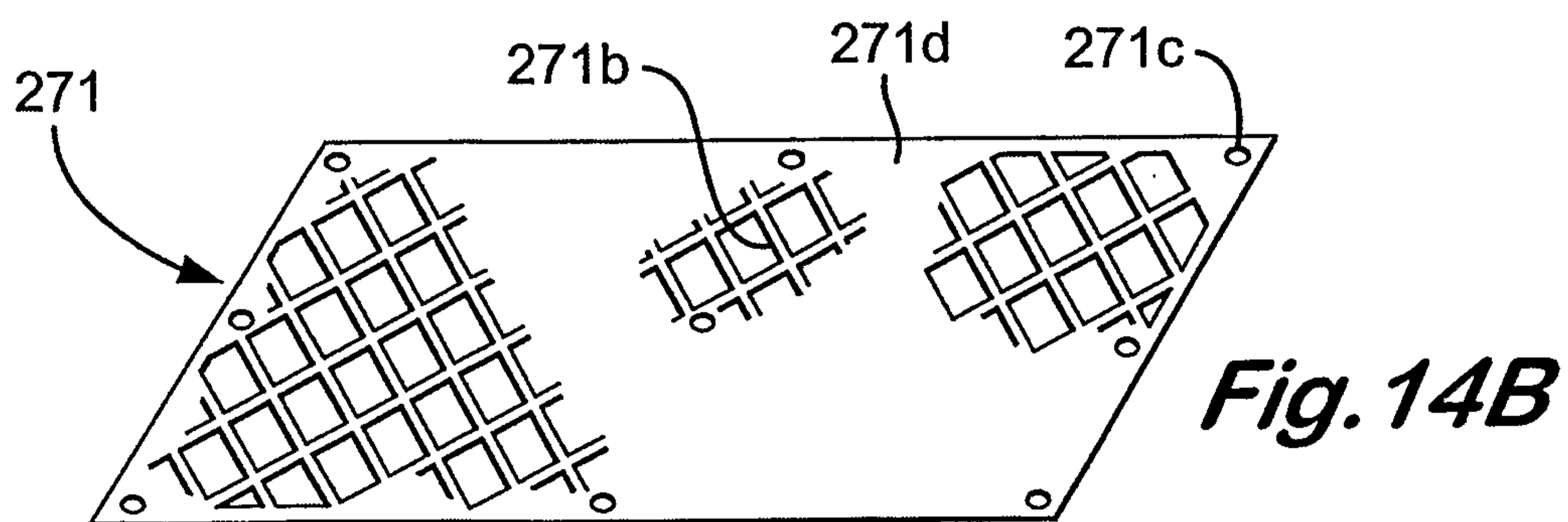
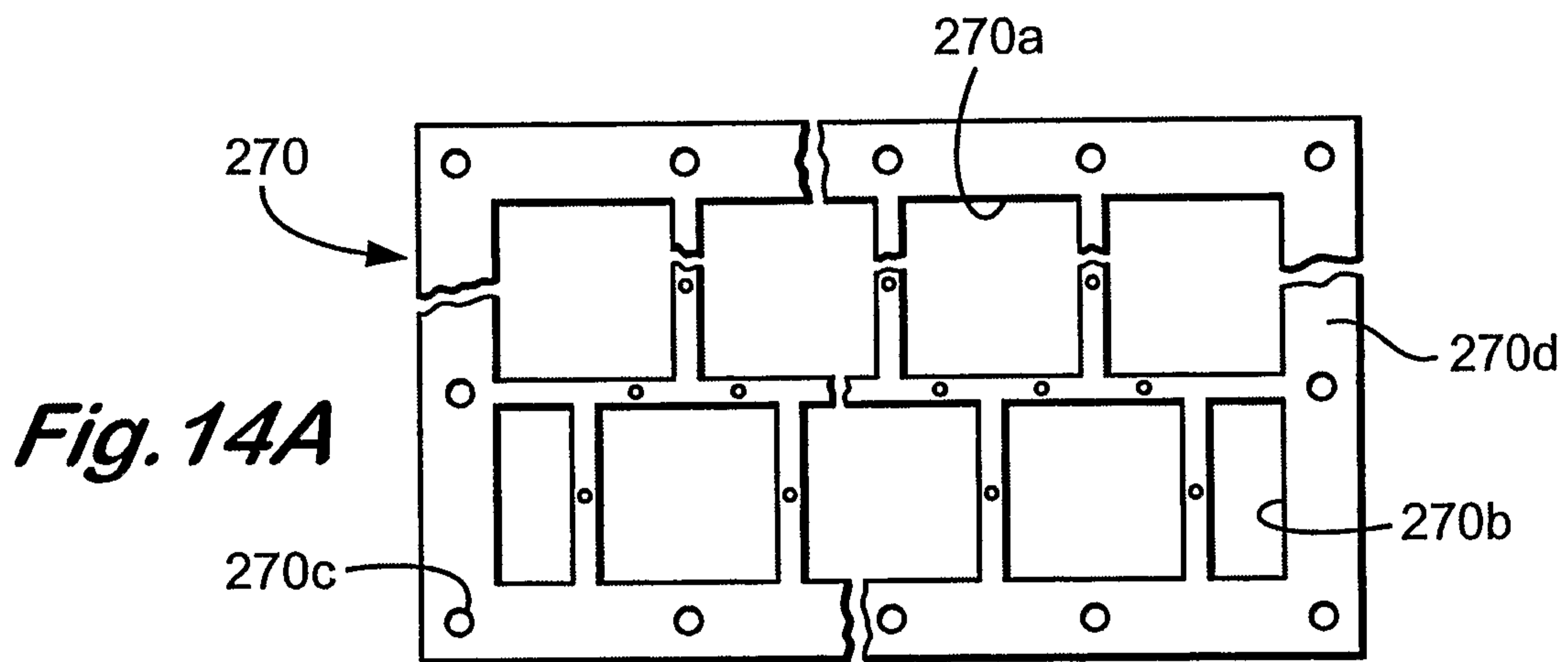
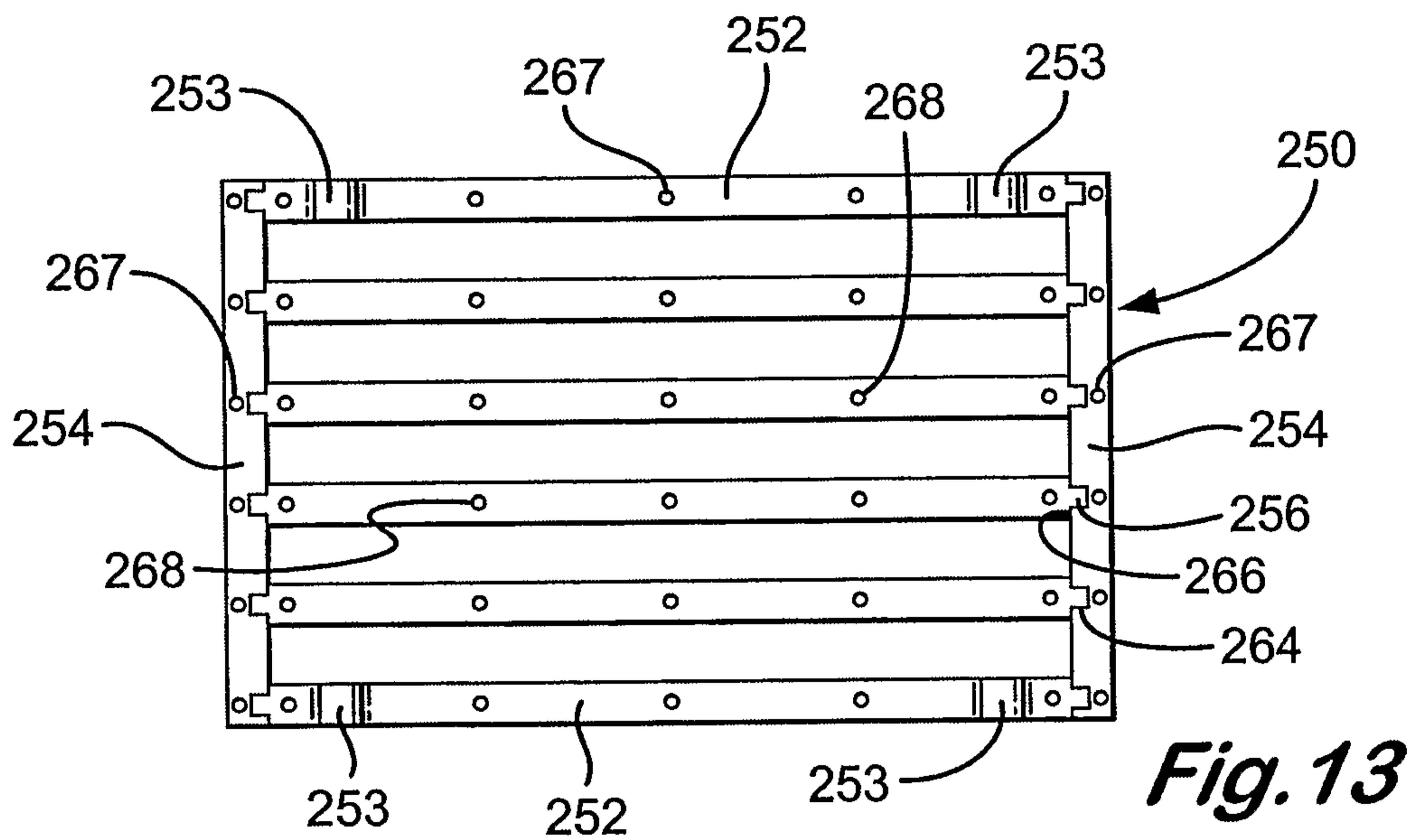

Fig. 15

