

(19) **DANMARK**

(10) **DK/EP 2642019 T3**



(12)

**Oversættelse af
europæisk patentskrift**

Patent- og
Varemærkestyrelsen

-
- (51) Int.Cl.: **D 06 F 67/04 (2006.01)**
- (45) Oversættelsen bekendtgjort den: **2016-09-26**
- (80) Dato for Den Europæiske Patentmyndigheds bekendtgørelse om meddelelse af patentet: **2016-06-22**
- (86) Europæisk ansøgning nr.: **13001101.8**
- (86) Europæisk indleveringsdag: **2013-03-05**
- (87) Den europæiske ansøgnings publiceringsdag: **2013-09-25**
- (30) Prioritet: **2012-03-20 DE 102012005457**
- (84) Designerede stater: **AL AT BE BG CH CY CZ DE DK EE ES FI FR GB GR HR HU IE IS IT LI LT LU LV MC MK MT NL NO PL PT RO RS SE SI SK SM TR**
- (73) Patenthaver: **Herbert Kannegiesser GmbH, Kannegiesserring 7, 32602 Vlotho, Tyskland**
- (72) Opfinder: **Heinz, Engelbert, Bretthorststrasse 272, 32602 Vlotho, Tyskland**
Sielermann, Jürgen, Clara-Schumann-Strasse 6, 73540 Heubach, Tyskland
- (74) Fuldmægtig i Danmark: **Chas. Hude A/S, H.C. Andersens Boulevard 33, 1780 København V, Danmark**
- (54) Benævnelse: **Fremgangsmåde til tilføring af vasketøjsstykker til en mangle eller lignende**
- (56) Fremdragne publikationer:
WO-A1-2008/141649
DE-A1- 3 320 419
DE-A1- 4 143 070
JP-A- 2007 092 255

Description

The invention relates to a method of supplying items of laundry to a mangle according to the preamble to Claim 1.

5

The method of the kind discussed here is intended for the operation of so-called feeding machines, which automatically supply items of laundry to a mangle or the like. Such feeding machines have multiple feeding stations at their disposal, each with a pair of feeding clamps. An item of laundry is fed by hand with the opposite corners of one edge into the feeding clamps of a respective feeding station. The feeding clamps transfer the item of laundry to spreading clamps. The item of laundry is stretched or spread out by the spreading clamps. Each item of laundry stretched by the spreading clamps is then deposited, with its stretched front edge facing to the front, directly on a supply conveyor or a depositing tray and from there onto the supply conveyor. The item of laundry in the stretched state is then supplied by the supply conveyor to the mangle or the like.

The invention relates to feeding machines which are capable of feeding either only large items of laundry in a single-track feed or, optionally, both large items of laundry in a single-track feed and also small items of laundry in a multi-track feed, in particular a dual-track feed. The expression single-track feeding is used if a large item of laundry is to be fed in, of which the front edge is so wide that it extends over half of the operating width of the supply conveyor and thus the operating width of the feeding machine. Dual-track feeding is possible in the case of smaller items of laundry if the front edge has a width which is smaller than half of the operating width of the feeding machine or of the supply conveyor. In the case of both single-track feeding and multi-track feeding, the spreading clamps are caused to move transversely in front of the supply conveyor and, to be precise, from the respective feeding station into positions in which the spreading clamps stretch the item of laundry and position it centrally ahead of the supply conveyor or, in the case of multi-track feeding, centrally ahead of the respective track.

In the case of previously disclosed feeding machines of the aforementioned kind, the spreading clamps collect the items of laundry from the respective feeding station according to the "first-in-first-out" principle. A suchlike method is disclosed, for example, in WO 2008/141649 A1. This often leads to quite long travel distances of the spreading clamps, in particular if the items of laundry are to be transferred successively from opposite outer feeding stations to the spreading clamps. A similarly disadvantageous device or a similarly disadvantageous method is described in DE 41 43 070 A1. There, the items of laundry are transferred from charging stations to those spreading clamps which are nearest to the loaded charging station. This method or this device is impractical, however, in particular for the operation of multi-track feeding machines or for the feeding of large items of laundry.

15 The invention has as its object to propose a method for the supply of items of laundry to a mangle, which permits a greater feeding rate.

A method for the accomplishment of this object exhibits the characterizing features of Claim 1. It is proposed therein, according to the invention, that the respective items of laundry are transferred to the spreading clamps in a regularly alternating manner by feeding clamps of two feeding stations from two different tracks, that is to say from different halves or sides of the feeding machine. Accordingly, items of laundry and, to be precise, preferably large items of laundry involving single-track feeding are always transferred continuously and successively to the spreading clamps from feeding stations ahead of different tracks or halves or sides. Therefore, where appropriate, items of laundry are not transferred to the spreading clamps one after the other from the same track, as in the case of previously disclosed feeding machines. In fact, the spreading clamps receive an item of laundry in a regularly alternating manner from a track on opposite sides of the centre of the supply conveyor. However, the collection of an item of laundry on the two tracks takes place according to the "first-in-first-out" principle. In the event that only a single item of laundry is present momentarily in the feeding clamps of a feeding station on the

respective track, the item of laundry is collected from the feeding station concerned. If, on the other hand, two items of laundry are present in the feeding stations of a single track, the item of laundry that is transferred to the spreading clamps will be the one which was transferred first to a feeding station. A combination of alternating tracks together with the "first-in-first-out" principle is thus realized according to the present invention. It is proposed in addition according to the invention that two tracks that are located one beside the other are positioned on opposite sides of a centre of the supply conveyor. The supply conveyor can have one or two tracks. In the case of two tracks, each track extends over one half of the supply conveyor or the feeding machine. Depending on the size of the item of laundry, the item of laundry is then fed in by single-track feeding or dual-track feeding. In the case of large items of laundry, the item of laundry extends over a track comprising the entire operating width, the middle of which track is the middle of the supply conveyor, that is to say the middle of the feeding machine, whereas, in the case of dual-track feeding, smaller items of laundry can be deposited on a track extending in each case over only one half of the feeding machine.

Preferably, the invention proposes at least three identical feeding stations ahead of a spreading device with the spreading clamps. In the case of three feeding stations, a central feeding station lies in the centre or on the longitudinal central axis of the supply conveyor, this being at the same time the longitudinal central axis of the feeding machine, whereas the two other feeding stations are disposed to the left and to the right of the centre. In the case of feeding machines with four feeding stations, two feeding stations are disposed on both sides of the feeding machine to the left and to the right of the longitudinal central axis and, to be precise, preferably symmetrically in relation to the longitudinal central axis. The presence of these at least three feeding stations ensures that an item of laundry is present at all times in at least one feeding station, so that the spreading clamps are able to collect an item of laundry uninterrupted from a feeding station and, to be precise, in a regularly alternating manner from one feeding station on one side or half of the centre of the supply conveyor and from one feeding station on the other side of the supply conveyor.

It is proposed in addition that the items of laundry are transferred to in each case one pair of spreading clamps from a total of at least three spreading clamps. The regular alternation in the transfer of the items of laundry from the feeding stations of different tracks or halves to the spreading clamps functions particularly efficiently if the two nearest of at least three spreading clamps in total take hold of the item of laundry. The spreading clamps constituting a pair of spreading clamps are able to alternate the track between two consecutive transfers of items of laundry. This is proposed preferably if, in the case of a spreading device with three spreading clamps, the inner spreading clamp shuttles between the different sides or halves of the supply conveyor.

A particularly advantageous illustrative embodiment of the method is explained in more detail below on the basis of the drawing. In the drawing:

15

fig. 1 depicts the transfer of an item of laundry from feeding clamps to spreading clamps,

fig. 2 depicts the spreading of the item of laundry by the spreading clamps,
20 and

fig. 3 depicts the transfer of a following item of laundry from the feeding clamps to the spreading clamps.

25 The method described here serves for the supply of items of laundry, not depicted in the figs., and, to be precise, above all large items of laundry, by a feeding machine to a mangle. The mangle, not depicted in the figs., is arranged in the feeding direction 10 behind a supply conveyor 11.

30 The feeding machine, depicted only schematically in fig. 1, serves for the optional supply of large or smaller items of laundry to the mangle or the like. The supply conveyor 11 has a width which corresponds to the operating width 14 of the feeding machine. A centre of the track 16 runs through the vertical

longitudinal central axis of the feeding machine, and thus lies in the centre of the maximum operating width 14 of the supply conveyor 11. In the case of dual-track feeding, the entire operating width 14 is subdivided into two tracks 15, 17 that are located one beside the other. These two tracks 15 and 17 are capable of feeding items of laundry independently of one another. Large items of laundry, which exceed the width of a track 15 or 17, are fed in over the full operating width 14, that is to say both of the tracks 15 and 17, by single-track feeding. Small items of laundry, which because of their width require only one track 15 or 17, are fed in by dual-track feeding, where appropriate with halves of the track of the supply conveyor 11 that are driven independently of one another.

When observed in the feeding direction 10 ahead of the supply conveyor 11, the illustrated device has a spreading device having a rail, not illustrated here, oriented transversely to the feeding direction, on which rail four spreading clamps 18, 19, 20, 21 are movably positioned in the depicted illustrative embodiment. It is also conceivable, however, for the spreading device to have more than four spreading clamps 18, 19, 20, 21, which are movable on the same rail or on separate rails. The spreading clamps 18 to 21 are capable of being moved independently of one another by different drives, not illustrated here, along the operating width 14 transversely to the feeding direction 10.

Furthermore, the device depicted here has four feeding stations 22, 23, 24, 25, which, when observed in the feeding direction 10, are disposed ahead of the spreading device or ahead of the spreading clamps 18 to 21. In the case of the illustrative embodiment illustrated here, respectively two feeding stations 22, 23 and 24, 25 are present on both sides of the centre of the track, being specifically the longitudinal central axis 16. The feeding stations 22 to 25 are of identical configuration. By contrast to the depicted illustrative embodiment, the device can also have more than four feeding stations or fewer than four feeding stations.

Respectively two feeding clamps 26 are assigned to each of the four feeding

stations 22 to 25. The feeding clamps 26 in each case have a clamping jaw, not illustrated here, by means of which they are able to take hold of the items of laundry, in each case at a corner region of one edge of the item of laundry, and to transfer them to the spreading clamps 18, 19, 20 or 21. In order to supply an
5 item of laundry to a mangle or the like, opposite corner regions of one edge of the item of laundry are suspended manually respectively in the two feeding clamps 26 of one of the feeding stations 22 to 25.

As illustrated in fig. 1, the item of laundry hanging on the two feeding clamps 26
10 is supplied and transferred to the spreading clamps 18 and 19 in the feeding direction 10. The two spreading clamps 18 and 19 move transversely to the feeding direction 10 and spread the items of laundry along the operating width 14. Depending on the size of the item of laundry, this is deposited over the entire operating width 14 of the supply conveyor 11 or only a single track, being
15 specifically halves 15 or 17 on opposite sides of the supply conveyor 11 on the belt conveyors 12 thereof. The item of laundry deposited on the belt conveyors 12 of the supply conveyor 11 is then supplied to the mangle or the like.

The method according to the invention is described in more detail below. It is
20 assumed in this case that a large item of laundry, which occupies more than half the operating width of the supply conveyor 11, is capable of being supplied in a single-track feed to the mangle or the like. It is further assumed that, first of all, two spreading clamps 18, 19 receive a large item of laundry from the left-hand (in relation to the figs.) feeding station 22. The spreading clamps 20, 21
25 remain in the area of the right-hand half of the track 17 in this case. The next item of laundry is received from the outer feeding station 25 of the right-hand half 17 and, to be precise, from the spreading clamps 19 and 20. The spreading clamps 18 and 21 remain unused in this case. An item of laundry is then received from the inner feeding station 23 of the left-hand half of the track 15.
30 This can take place from the spreading clamps 19, 20. An item of laundry is then received from the inner feeding station 24 of the right-hand half of the track 17. The spreading clamps 19, 20 or 18, 19 are used for this purpose. A further item of laundry is subsequently received from the feeding station 22 of the left-

hand half of the track 15.

It can be appreciated from the above-mentioned approach that large items of laundry, of which the front edge is greater than the width of one half 15, 17 of the supply conveyor 11, are received continuously in a regularly alternating manner from a feeding station 22 or 23 of the left-hand half 15 and from a feeding station 24, 25 of the right-hand half 17 and then once more from the left-hand half 15. The method according to the invention prevents items of laundry from being received repeatedly one after the other from feeding stations 22, 23, 24 or 25 of the same halves 15 or 17.

Even if, in the approach described above, items of laundry are also received in particular by alternation from different feeding stations 22, 23 of the left-hand half 15 and the feeding stations 24, 25 of the right-hand half 17, it is also conceivable within the scope of the invention to undertake the regular alternation of the receiving of the items of laundry only in relation to the halves 15, 17, although not inside the respective half 15, 17. The item of laundry can thus be received according to the "first-in-first-out" principle from the feeding station 22 or 23 or 24 or 25 inside the respective half 15, 17, in which an item of laundry is present for the longest time. It is also conceivable that, in the area of a half 15 or 17 in conjunction with the regular alternation of the halves 15, 17, an item of laundry is collected repeatedly from the same feeding station 22, 23, 24 or 25. This is particularly useful if one of the feeding stations 22, 23, 24 or 25 remains unused, because not every feeding station 22, 23, 24, 25 has a movement person in attendance.

In the case of a feeding machine which is selectively suitable for single-track or dual-track feeding, the single-track feeding also takes place according to the previously described method. In the case of dual-track feeding, on the other hand, items of laundry are deposited continuously on the left-hand half 15 from the feeding stations 22, 23 ahead of the left-hand half 15. The same procedure is followed in respect of the feeding station 24 and 25 ahead of the right-hand half 17. In the case of dual-track feeding, the spreading clamps 18, 19 ahead of

the left-hand half 15 serve only said left-hand half 15, whereas the spreading clamps 20, 21 ahead of the right-hand half 17 also serve only the right-hand half 17.

5 In the case of the illustrated feeding machine with four spreading clamps 18, 19, 20 and 21, it is proposed that, for the single-track feeding of large items of laundry, an outer spreading clamp, in the depicted illustrative embodiment being the right-hand outer spreading clamp 21, remains unused. The left-hand outer spreading clamp 18 then serves only for the receiving of items of laundry from
10 the feeding stations 22 and 23 from the left-hand half of the track 15, and the spreading clamps 20 serve only for the receiving of items of laundry from the feeding stations 24 and 25 ahead of the right-hand half of the track 17. The central spreading clamp 19, on the other hand, shuttles between the halves 15 and 17.

15

In the case of a feeding machine with only three feeding stations, respectively one feeding station is present ahead of the left-hand half 15 and the right-hand half 17, and the third feeding station is present on the longitudinal central axis 16 of the centre of the feeding machine, that is to say between the halves 15
20 and 17. A regular alternation also takes place in the case of a feeding machine with only three feeding stations and, to be precise, in the sequence such that an item of laundry is received initially from the left-hand feeding station, then from the right-hand feeding station and then from the central feeding station. The process then starts again with the left-hand feeding station. As an alternative, it
25 is also possible to proceed according to the sequence in which an item of laundry is initially received from the left-hand feeding station, then from the central feeding station, and then from the right-hand feeding station, and finally starting again with the left-hand feeding station. In the case of feeding machines with only three feeding stations, it may be sufficient to provide only two
30 spreading clamps or only three spreading clamps.

It is also conceivable that, in the case of feeding machines with four feeding stations 22, 23, 24 and 25 and two pairs of spreading clamps, one pair of

spreading clamps is assigned in each case to one half 15, 17, and items of laundry are received only from the feeding stations 22, 23 of the left-hand half 15 with the same pair of spreading clamps 18, 19, whereas the spreading clamps 20, 21 receive items of laundry only from the feeding stations 24, 25 of the right-hand half 17. All four spreading clamps 18, 19, 20, 21 are then alternately in operation. Thus, no spreading clamp 20 shuttles from one half 15 to the other half 17 and vice versa.

Illustrated in fig. 3 is the manner in which a further item of laundry is supplied to the supply conveyor 11. The previously moved spreading clamp 19 remains in the half 17 for this purpose and, together with the spreading clamp 20, takes hold of an item of laundry from the feeding clamps 26 of the feeding station 25. The fact that the spreading clamp 19 remains in the area of the half 17, in order to take hold of laundry there, and does not travel back in the empty state into the area of the half 15, means that the empty run of the spreading clamps 18, 19, 20, 21 is shortened and the feeding rate is increased. Whether the spreading clamps 19 and 20 in this case take hold of items of laundry from the feeding station 24 or 25 subsequently determines which of the two feeding stations 24, 25 is provided first with an item of laundry.

Following the renewed supply of an item of laundry by the spreading clamps 19 and 20 to the supply conveyor 11, in which case the spreading clamp 19 is moved back into its original area of the half 15, the spreading clamp 19 remains in this area for the supply of a further item of laundry.

25

List of Reference Designations:

- | | |
|----|--------------------|
| 10 | feeding direction |
| 30 | 11 supply conveyor |
| 12 | belt conveyor |

	13	axis
	14	operating width
5	15	left-hand half
	16	longitudinal central axis
	17	right-hand half
10	18	spreading clamp
	19	spreading clamp
15	20	spreading clamp
	21	spreading clamp
	22	feeding station
20	23	feeding station
	24	feeding station
25	25	feeding station
	26	feeding clamp
	27	track width
30		

Patentkrav

1. Fremgangsmåde til tilføring af vasketøjsstykker til en mangle ad en eller flere baner, og hvor vasketøjsstykkerne ved hjælp af ved siden af hinanden anbragte hjørneområder manuelt indføres i tilføringssklemmer (26) ved flere tilføringstationer (22, 23, 24, 25), og hvor vasketøjsstykkerne fra tilføringssklemmerne (26) til nogle spredesklemmer (18, 19, 20, 21) overføres til en på tværs af en tilføringretningen (10) for vasketøjsstykker til manglen anordnet spredindretning, og hvor spredesklemmerne (18, 19, 20, 21) udbreder vasketøjsstykket og lægger det enkelte vasketøjsstykke på en tilføringstransportør (11) eller på en hertil tilforordnet fralægningsliste, **kendetegnet ved, at** tilføringstransportøren (11) funktionelt set er opdelt i to baner, som – set i tilføringretningen (10) – er anbragt ved siden af hinanden, og som til enhver tid har mindst to tilføringstationer (22, 23, 24, hhv. 25), og hvor store vasketøjssemner, som kræver flere baner, overføres til spredesklemmerne (18, 19, 20, 21) på en regelmæssigt skiftende måde fra tilføringssklemmer (26) på tilføringstationerne (22, 23, 24, 25) hørende til forskellige baner, og hvor tilføringstationen (22, 23, 24, 25) hørende til vedkommende bane (15, 17), og som har været den første til at modtage et vasketøjsstykke, overfører vasketøjsstykket til spredesklemmerne (18, 19, 20, 21).

2. Fremgangsmåde ifølge krav 1, **kendetegnet ved, at** hver bane strækker sig over den halve arbejdsbredde af tilføringstransportøren (11), og at hver bane er dannet ved hjælp af en halvdel af tilføringstransportøren (11), hvilke halvdele er placeret på modsatte sider af en langsgående midterakse (16) af tilføringstransportøren (11), og at der i tilfælde af tilføring via en enkelt bane findes en banemidte.

3. Fremgangsmåde ifølge krav 1 eller 2, **kendetegnet ved, at** vasketøjsstykkerne i det enkelte tilfælde overføres til et par spredesklemmer ud af i det mindste tre spredesklemmer (18, 19, 20, 21).

4. Fremgangsmåde ifølge et af de foregående krav, **kendetegnet ved, at** overføringen af vasketøjsstykket fra tilføringsklemmerne (26) til vedkommende spredesklemmer (18, 19, 20, 21) sker for de vasketøjsstykker, som har den mindste afstand til tilføringsklemmerne (26).

5

5. Fremgangsmåde ifølge et af de foregående krav, **kendetegnet ved, at** det for så vidt der foreligger en spredeindretning med tre eller fire spredesklemmer (18, 19, 20, 21) gælder, at en indvendigt beliggende spredesklemme (20) bevæges frem og tilbage mellem de forskellige baner.

10

6. Fremgangsmåde ifølge et af de foregående krav, **kendetegnet ved, at** det for så vidt der foreligger en spredeindretning med fire spredesklemmer (18, 19, 20, 21) gælder, at de indre spredesklemmer (19, 20) bevæges frem og tilbage mellem de forskellige baner.

15

7. Fremgangsmåde ifølge et af de foregående krav, **kendetegnet ved, at** de ydre spredesklemmer (18, 21) til enhver tid kun modtager vasketøjsstykker fra én bane.

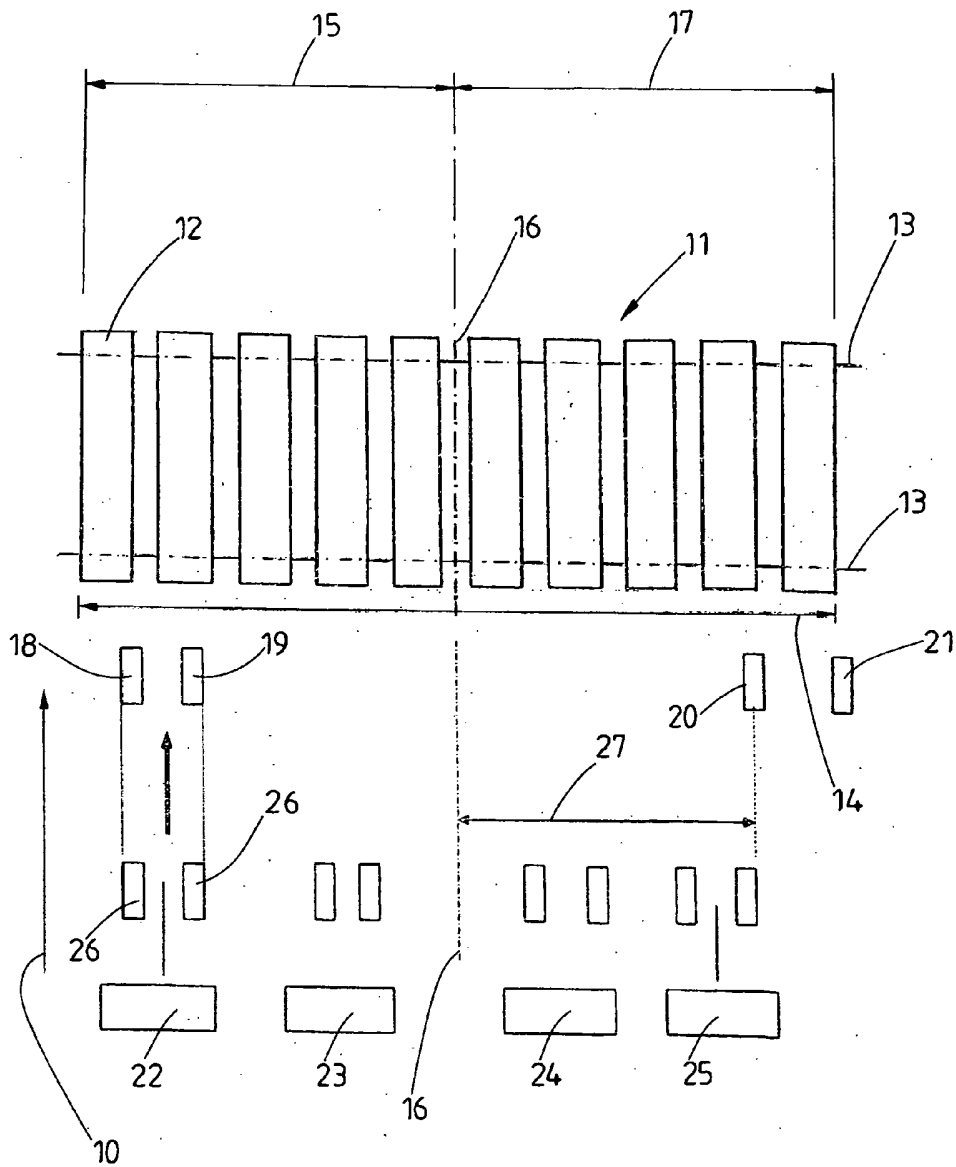

Fig. 1

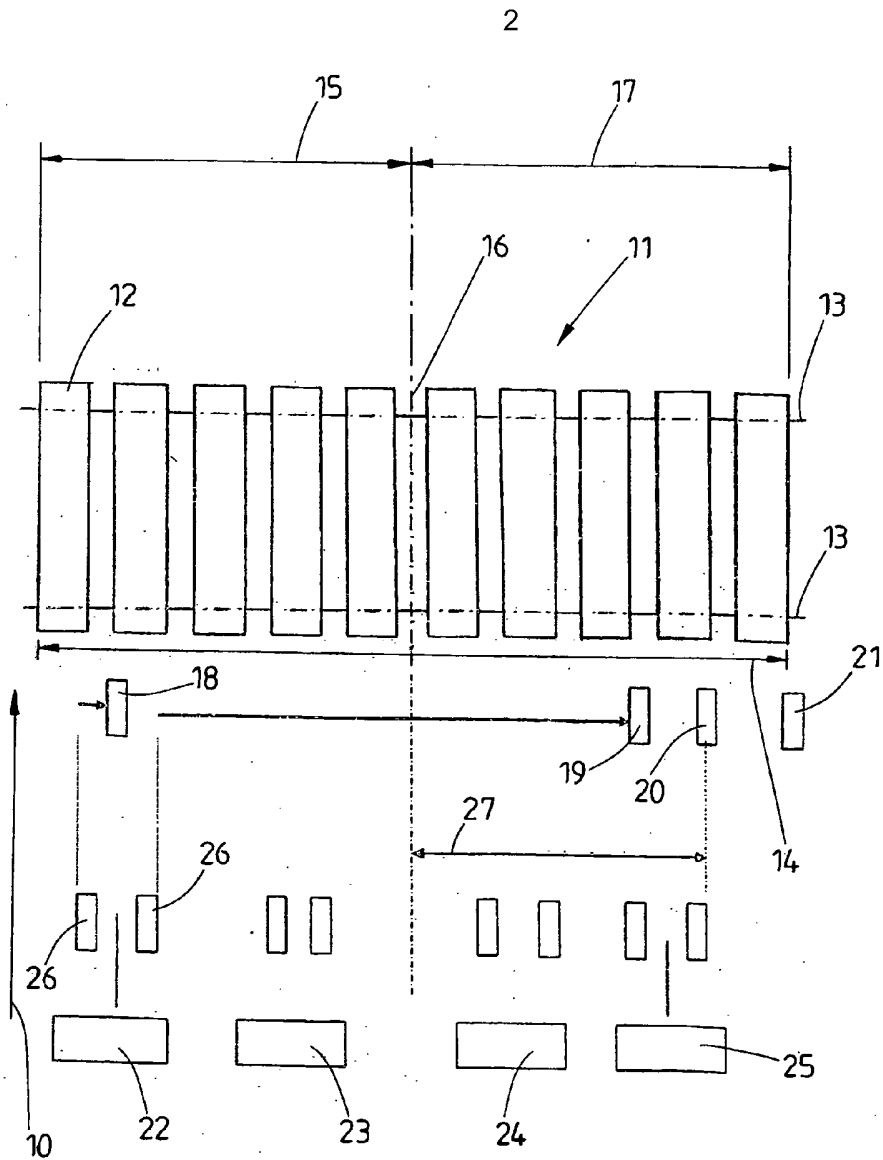

Fig. 2

3

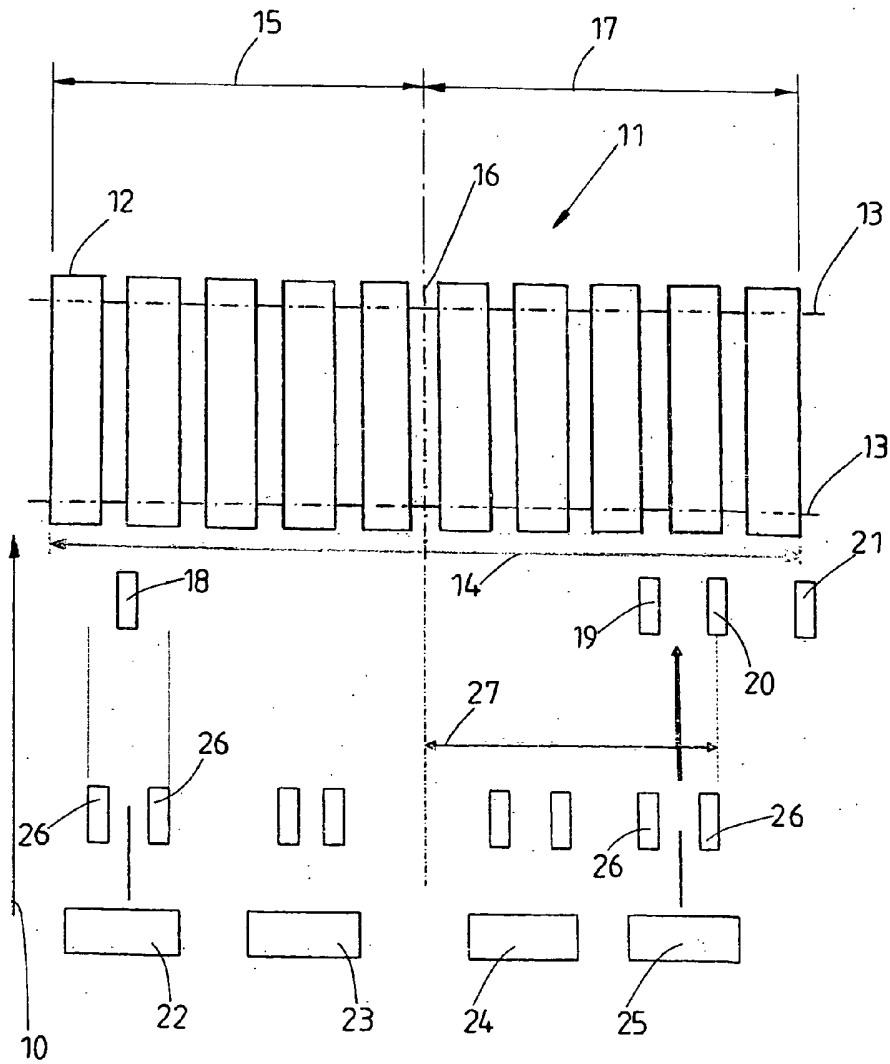

Fig. 3